



MOTORRAD ERSATZTEILE UND ZUBEHÖR

PIÈCES DÉTACHÉES ET ACCESSOIRES POUR MOTO

MOTORCYCLE SPAREPARTS AND ACCESSORIES

XDB500H  2015-

Lucas





	D	GB	FR	CZ	ES	GR	PL	RU	TR
	Fahrzeug/ Modell	Vehicle Model	Modèle de véhicule	Vozidlo/model	Modelo del vehículo	Μοντέλο	Pojazd/ model	Модель	Model
	Vorderachse	Front axle	Essieu avant	Přední náprava	Eje delantero	Μπροστινός άξονας	Oś przednia	Передняя ось	Ön aks
	Hinterachse	Rear axle	Essieu arrière	Zadní náprava	Eje trasero	Πίσω άξονας	Oś tylna	Задняя ось	Arka aks
	Scheiben- bremsbeläge	Brake pads	Plaquettes de frein	Třecí segmenty	Pastillas de disco	Τακάκια φρένων	Okladziny hamulca tarczowego	Тормозные колодки дисковые	Fren balataları
	Bremsbacken	Brake shoes	Mâchoires de frein	Brzdové čelisti	Zapatas de freno	Σιαγόνες φρένων	Szczęki hamulcowe	Тормозные колодки барабанные	Fren pabuçları
	Bremsscheiben	Brake Discs	Disques de freins	Brzdový kotouč	Disco de freno	Διακόφρενο	Tarcza hamulcowa	Тормозной диск	Disk
	Stahlflexleitung	Steelbraided hose	Durites de freins	Opletená brzdová hadice	Latiguillos de freno	Εύκαμπτος σωλήνας από χάλυβα	Przewód w oplocie stalowym	Шланг в металлической оплётке	Çelik fren hortum
	Doppel- hohlschraube	Double banjo bolt	Vis de banjo double alimentation	Dvojíť dutý šroub	Racord doble	Διπλή κοίλη βίδα	Śruba drażona podwójna	Двойной полый винт	Çift banjolu saplama
	Einfache Hohlschraube	Single banjo bolt	Vis de banjo simple alimentation	Jednoduchý dutý šroub	Racord simple	Απλή κοίλη βίδα	Śruba drażona pojedyncza	Одинарный полый винт	Tek banjolu saplama
	Doppel- hohlschraube enthalten	Double banjo bolt included	Vis de banjo double alimenta- tion incluse	Obsahuje dvojíť dutý šroub	Racord doble incluido	Διπλές κοίλες βίδες περιλαμβάνονται	Śruba drażona podwójna w komplecie	Двойной полый винт прилагается	Çift banjolu saplama dahil
	Kupplungs- belagsatz	Clutch Friction Plate Kit	Kit disques garnis	Sada spojko- vého obložení	Juego de revestimiento para discos de embrague	Σετ επένδυσης συμπλέκτη	Zestaw okładzin sprzęgła	Набор накладок сцепления	Debriyaj balatası - takım
	Kupplungslei- tung	Clutch hoses	Durites d'em- brayage	Spojkové potrubí	Latiguillos de embrague	Αγωγός συμπλέκτη	Przegub sprzęgła	Шланг сцепления	Debriyaj hortumları
	Satz Kupplungsfedern	Clutch spring kit	Ressorts d'embrayage	Sada spojkových pružin	Muelle de embrague	Σετ ελατηρίων συμπλέκτη	Zestaw sprężyn sprzęgła	Набор пружин сцепления	Debriyaj Yayı Takım
	Kupplungs- zwischen- scheibensatz	Clutch plate kit	Kit disques lisses	Sada spojkových mezikroužků	Juego de discos de embrague	Σετ ενδιάμεσων πλακών συμπλέκτη	Zestaw tarcz pośrednich sprzęgła	Набор промежуточных дисков сцепления	Debriyaj plakası
	ABE, TÜV- Eintragung entfällt	TUV Approved	Approuvé TÜV	TÜV Zapsání odpadá	Comprovado por el TÜV	Χωρίς καταχώρηση, TÜV	TÜV brak wpisu	Одобрено АВЕ, TUV	TÜV onaylı
	Doppelscheibe, 2 Sätze not- wendig	2 sets required	2 jeux pour l'avant	Dvojíť kotouč, 2 sady nutné	Doble disco	Διπλός δίσκος, απαιτούνται 2 σετ	Podwójna tar- cza, konieczne 2 zestawy	Два тормозных диска, необходимо 2 комплекта	2 takım kullanılı
	auf Anfrage	Application to be added	Application à ajouter	V přípravě	En preparacion	Κατόπιν αίτησης	Na zapytanie	По запросу	Uygulamaya alınacak
	Links	Left	Gauche	Vlevo	Izquierdo	Αριστερά	Lewy	Слева	Sol
	Rechts	Right	Droite	Vpravo	Derecho	Δεξιά	Prawy	Справа	Sağ



© TRW Automotive 2015



TRW KFZ Ausrüstung GmbH

Rudolf-Diesel-Str. 7
D-56566 Neuwied



Postfach 23 42
D-56513 Neuwied
Germany



Telefon +49 (0) 2631 912 0
Telefax +49 (0) 2631 912 110

Publication No. XDB500H Printed in Germany 23M/0615/zwei&freunde



1



2



3

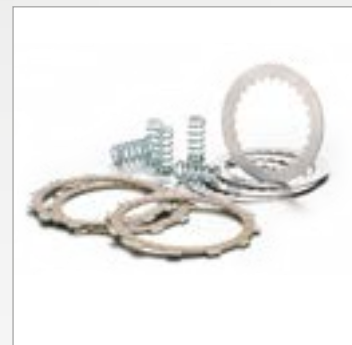

4



5



DAS UNTERNEHMEN

LA SOCIÉTÉ THE COMPANY

Mit einem Umsatz von 17,5 Mrd. USD im Jahr 2014 rangiert TRW unter den weltweit führenden Zulieferern der Automobilindustrie.

Das Unternehmen mit Hauptsitz in Livonia, Michigan, USA, ist über seine Niederlassungen in 26 Ländern präsent und beschäftigt mehr als 65.000 Mitarbeiter weltweit.

Zum Produktportfolio von TRW Automotive zählen integrierte Fahrzeugregel- und Fahrerassistenzsysteme, Bremssysteme, Lenkungssysteme, Aufhängungssysteme, Sicherheitssysteme für Fahrzeuginsassen (Sitzgurte und Airbags), Elektronik, Motor-komponenten, Befestigungssysteme sowie Aftermarket-Ersatzteile und -Leistungen.

TRW ist neben der ISO 9001 nach ISO/TS 16949 zertifiziert, dem neuesten Qualitätsstandard der internationalen Fahrzeugindustrie.

With a turnover of 17.5 billion USD in 2014, TRW is one of the worldwide leading suppliers to the automotive industry.

The company with its headquarters in Livonia, Michigan, USA, maintains branch offices in 26 countries and employs more than 65,000 people worldwide.

The product portfolio of TRW Automotive includes integrated vehicle control and driver assistance systems, braking systems, steering systems, suspension systems, occupant safety systems (seat belts and airbags), electronic systems, engine components, fastening systems as well as aftermarket spare parts and services.

Together with ISO 9001, TRW is certified according to ISO/TS 16949, the latest quality standard within the international automotive industry.

Avec un chiffre d'affaires de 17,5 milliards de dollars US en 2014, TRW se classe parmi les principaux fournisseurs de l'industrie automobile au niveau mondial.

L'entreprise, dont le siège social est situé à Livonia, dans le Michigan (USA), possède des filiales dans 26 pays et occupe plus de 65 000 collaborateurs dans le monde.

Dans le portefeuille des produits de TRW Automotive, on retrouve des systèmes de régulation pour les véhicules et systèmes d'assistance pour les conducteurs, des systèmes de freinage, des systèmes de direction, des systèmes de suspension, des systèmes de sécurité pour les occupants des véhicules (ceintures et airbags), des systèmes électroniques, des composants pour les moteurs, des systèmes de fixation, mais aussi des pièces de rechange et prestations de service.

TRW est certifié non seulement ISO 9001 mais également ISO/TS 16949, le nouveau standard de qualité de l'industrie automobile internationale.



TRW Automotive Aftermarket:

- » TRW ist einer der führenden Anbieter von qualitativ hochwertigen Kfz-Ersatzteilen, sowie ein führendes Unternehmen in den Bereichen Wartung, Diagnose, Schulung und technische Unterstützung im unabhängigen Aftermarket und für die Vertragswerkstätten der Fahrzeughersteller.
- » Die Lager in Neuwied und Überherrn bilden das europäische Aftermarket- und Vertriebszentrum. Gemeinsam verfügt man über 32 000 m² Lagerfläche und 55 000 Stellplätze.
- » Im deutschsprachigen Raum sind TRW Motorrad-Bremsbeläge eine führende Marke.

TRW Automotive Aftermarket:

- » *TRW is one of the leading providers of high-quality automotive spare parts as well as a leading company in the areas of maintenance, diagnostics, training and technical support for the independent automotive aftermarket and for the authorised workshops of the vehicle manufacturers.*
- » *The European Aftermarket Headquarter and Salescenter is based in Neuwied and Überherrn. The depots cover an area of 32 000 m² with around 55 000 storage positions.*
- » *TRW motorcycle brake pads are a leading brand in the German-speaking area.*

TRW Automotive Aftermarket:

- » *TRW est un des principaux fournisseurs de pièces de rechange automobiles de qualité, ainsi qu'une entreprise de pointe dans les secteurs de l'entretien, du diagnostic, des formations et des aides techniques pour le marché de l'après-vente indépendant et les ateliers des fabricants de véhicules.*
- » *Le siège TRW pour le marché de l'après-vente (pièces de rechange) et la plateforme logistique se situent respectivement à Neuwied et à Überherrn. L'entrepôt de 32 000 m² dispose d'environ 55 000 emplacements.*
- » *Les plaquettes de frein moto TRW sont un des marques leader sur le marché dans les pays germanophones.*

Die Pioneer 10 passiert den Mond

Pioneer 10 passes the moon

Pioneer 10 passe par la lune

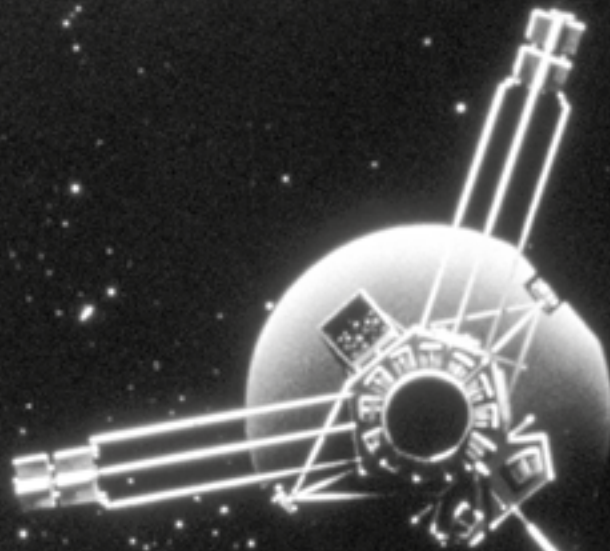

1874 » Lucas

1879 » Lucas

1943 » Lucas

1952 » Lucas

1953 » TRW

1958 » TRW

1965 » TRW

1970 » Lucas

1975 » Lucas

1978 » Lucas

1983 » TRW

1988 » Lucas

1989 » TRW

1994 » Lucas

1999 » TRW
» Lucas

2001 » TRW

2004 » TRW

2012 » TRW

2015 » ZF
» TRW

FIRMENHISTORIE – LUCAS WIRD ZU TRW

*L'HISTOIRE DE LA SOCIÉTÉ –
LUCAS DEVIENT TRW*

*THE COMPANY'S HISTORY –
LUCAS BECOMES TRW*

Joseph Lucas startet die Herstellung von Schiffslampen in England	<i>Joseph Lucas starts manufacturing ship lamps in England</i>	<i>Joseph Lucas entreprend la fabrication de feux de navigation en Angleterre</i>
Lucas beliefert Europas sehr junge Automobilindustrie	<i>Lucas supplies to the very new automobile industry in Europe</i>	<i>Lucas devient fournisseur de la très jeune industrie automobile européenne</i>
Lucas übernimmt Girling und expandiert ins Geschäft mit Bremsen, Bremssystemen und Kupplungsbetätigung	<i>Lucas acquires Girling and expands the business to include brakes, brake systems and clutches</i>	<i>Lucas reprend Girling et s'étend dans ce secteur d'activité avec les freins, systèmes de freinage et commandes d'embrayage</i>
Lucas Girling bringt die erste Scheibenbremse der Welt auf den Markt	<i>Lucas Girling launches the world's first disc brake</i>	<i>Lucas Girling met sur le marché le premier frein à disque au monde</i>
Simon Ramo und Dean Wooldridge gründen The Ramo-Wooldridge Corp.	<i>Simon Ramo and Dean Wooldridge found The Ramo-Wooldridge Corp.</i>	<i>Simon Ramo et Dean Wooldridge fondent la Ramo-Wooldridge Corporation</i>
Fusion von Thompson Products mit Ramo-Wooldridge. Jetzt, Thompson-Ramo-Wooldridge, konstruiert und fertigt die Pioneer I, das erste Raumschiff der Welt.	<i>Thompson Products merges with Ramo-Wooldridge. Now, Thompson-Ramo-Wooldridge, designs and builds Pioneer I, the world's first ever spacecraft.</i>	<i>Fusion de Thompson Products et de Ramo-Wooldridge. C'est à cette époque que Thompson-Ramo-Wooldridge conçoit et fabrique le Pioneer I, le premier engin spatial au monde</i>
Abkürzung des Firmennamens zu TRW , Inc.	<i>The company name is abbreviated to TRW, Inc.</i>	<i>Abréviation de la raison sociale en TRW, Inc.</i>
TRW liefert die Mondlanderaketen für die Apollo-Mission	<i>TRW supplies the moon landing rockets for the Apollo mission</i>	<i>TRW fournit les fusées lunaires pour les missions Apollo</i>
Lucas Girling liefert Motorrad Ersatzteile an europäische Hersteller (z. B. Moto Guzzi, Triumph, Hercules, Kreidler)	<i>Lucas Girling supplies original equipment for motorbikes to European manufacturers (including Moto Guzzi, Triumph, Hercules and Kreidler)</i>	<i>Lucas Girling fournit des pièces de rechange pour motos aux constructeurs européens (Moto Guzzi, Triumph, Hercules et Kreidler, notamment)</i>
Lucas Girling verkauft von Deutschland aus die ersten asbestfreien Motorrad Bremsbeläge	<i>Lucas Girling markets the first asbestos-free motorbike brake pads from within Germany</i>	<i>Lucas Girling commercialise la première plaquette de frein moto sans amiante d'Allemagne</i>
Mike Hailwood schreibt Motorradgeschichte und wird zum 9 mal Weltmeister mit Sponsor Lucas Girling	<i>Mike Hailwood writes biking history, becoming world champion for the 9th time with sponsor Lucas Girling</i>	<i>Mike Hailwood écrit une page de l'histoire de la moto et décroche à 9 reprises le titre de champion du monde avec pour sponsor Lucas Girling</i>
Die TRW Pioneer 10 ist das erste von Menschen gebaut Objekt, das unser Sonnensystem verlässt.	<i>The TRW Pioneer 10 becomes the first man-made object to travel beyond our solar system.</i>	<i>La sonde Pioneer 10 de TRW est le premier objet construit par l'homme à quitter notre système solaire</i>
Lucas Girling beginnt die Produktion von Stahlflex Bremsleitungen für Motorräder	<i>Lucas Girling starts production of Stahlflex brake lines for motorbikes</i>	<i>Lucas Girling commence la production des flexibles de frein acier Stahlflex pour la moto</i>
TRW entwickelt das erste System mit Frontairbag und Sensor und legt somit den Grundstein für den heutigen Konzernslogan „Safety“	<i>TRW develops the first front airbag and sensor system, laying the foundations for today's corporate slogan "Safety"</i>	<i>TRW élabore le premier système avec airbag avant et capteur et pose ainsi la première pierre du slogan actuel du groupe, «Safety»</i>
Lucas beginnt mit dem Vertrieb von Motorrad-Kupplungen	<i>Lucas starts marketing bike clutches</i>	<i>Lucas s'engage dans la distribution d'embrayages pour motos</i>
TRW übernimmt den Automobilzulieferer Lucas	<i>TRW acquires automotive supplier Lucas</i>	<i>TRW reprend l'équipementier automobile Lucas</i>
TRW führt sein Brems Scheibenprogramm für Motorräder ein	<i>TRW launches its range of motorbike brake discs</i>	<i>TRW lance son programme de disques de frein pour la moto</i>
Die TRW Automotive Holdings Corp. geht an die Börse	<i>TRW Automotive Holdings Corp. goes public</i>	<i>La TRW Automotive Holdings Corp. entre en bourse</i>
Auditierung der TRW Motorradteile nach Automobil-Standard	<i>Auditing of the TRW motorcycle parts according to the automotive standard</i>	<i>Audit des pièces pour motos TRW selon les standards automobiles</i>
ZF übernimmt TRW – THE POWER OF ²	<i>ZF acquires TRW – THE POWER OF²</i>	<i>ZF reprend TRW – THE POWER OF²</i>

VERKAUFSFÖRDERUNG

PRODUITS PUBLICITAIRES MERCHANDISING



Aufnäher
Badge
Écusson

LDW398 12 x 4,5 cm



Aufkleber
Sticker
Autocollant

TRW104A 12 x 3,5 cm
TRW104B 15 x 4 cm



Aufkleber
Sticker
Autocollant

LDW222 20 x 4,5 cm



Aufkleber
Sticker
Autocollant

LDW399 12 x 4 cm

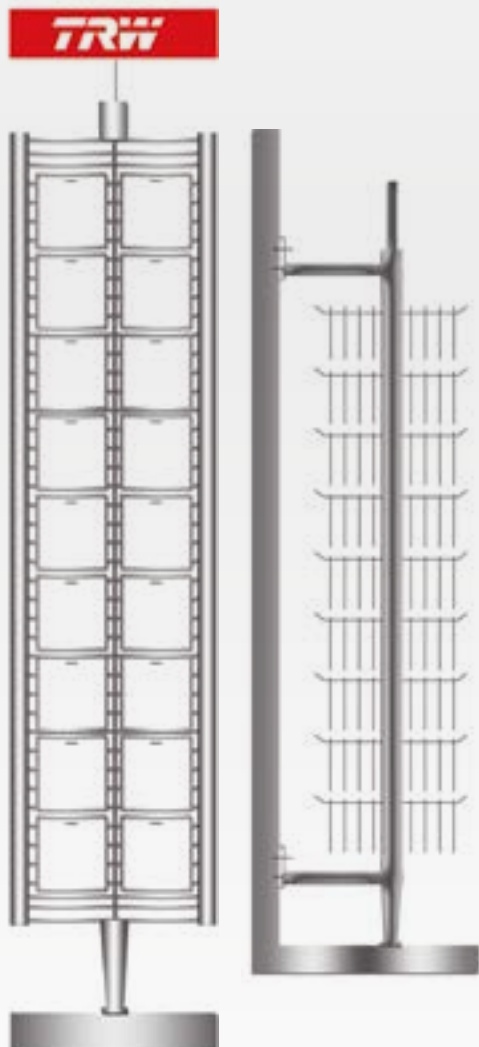

Ständer für Ersatzteile
Spare parts display
Affichage pièces détachées

MCD270 40 x 220 cm



Hocker
Stool
Tabouret

LDW316MC-DE
26 x 42 cm



Thekenständer
Counter display
Présentoir pour comptoir

MCD290 60 x 90 cm



Präsentation Varioflex
Presentation Varioflex
Présentation Varioflex

MCD295 19 x 30 cm



Plakat „Bremse“ und „Zubehör“
Poster „Brakes“ and „Accessories“
Affiche «Freinage» et «Accessoires»

- LDW359MC-DE** „Bremse“, DIN A2
- LDW359MC-EN** „Brake“, DIN A2
- LDW371MC-DE** „Zubehör“, DIN A2
- LDW371MC-EN** „Accessories“, DIN A2



Broschüre, 26-seitig
Booklet, 26 pages
Brochure, 26 pages

- XBM002 CZ** Czech
- XBM002 DE** Deutsch
- XBM002 EN** English
- XBM002 ES** Español
- XBM002 FR** Français
- XBM002 IT** Italiano
- XBM002 NL** Nederlandse
- XBM002 PL** Polsky
- XBM002 RU** Russkiy



Flyer „Offroad“
DE/EN DIN A6



Display Ellipse 50 x 160 cm
Display Ellipse
Présentoir elliptique

- | | |
|---------------------------|---------------------------|
| XSM004 DE Deutsch | XSM004 IT Italiano |
| XSM004 EN English | XSM004 PL Polsky |
| XSM004 ES Español | XSM004 RU Russkiy |
| XSM004 FR Français | |



Fahne
Flag
Drapeau
TRW133 150 x 300 cm



Spannband
Banner
Bannière
TRW108 75 x 300 cm

PROMOTION



T-Shirt
LOW403



Kappe
Cap
Casquette
TRW198



Flaschenöffner
Bottle opener
Décapsuleur
TRW129B



Schlüsselband
Lanyard
Porte-clef
TRW006



Kugelschreiber
Ballpoint pen
Stylo bille
LDW333MC

automotive **Diamonds** ✨

Jetzt anmelden! Werden Sie Mitglied unseres Prämienprogramms unter www.automotivediamonds.com.

Register now! Take part in our awards programme at www.automotivediamonds.com.

Inscrivez-vous dès maintenant! Participez à notre programme et remportez de nombreux cadeaux sur www.automotivediamonds.com.

Welcome to the **DIAMOND HUNT**



TRW

DENSO

Gates

PHILIPS

**COOPERS
FLAAM FILTERS**

**FILTERS
purflux**

FRAM

socefiPRO

NEUHEITEN LENKER

NOUVEAUTÉS GUIDON

NEW PRODUCTS – HANDLEBARS

HARLEY DAVIDSON



RACING-Stummel für Harley Davidson

Der beste und einfachste Weg, Custom Bikes auf den Cafe Racer – Look umzubauen. Dabei überraschend komfortabel durch die moderate Geometrie mit einem Lenkrohrwinkel von 5,5 Grad.

RACING clip-ons for Harley Davidson

The best and easiest way to convert custom bikes to the café racer look. Surprisingly comfortable thanks to the moderate geometry with a handlebar angle of 5.5 degrees.

GUIDON BRACELET pour Harley Davidson

Le moyen le plus simple et aisé pour donner à votre moto un look « Café racer », tout en étant étonnamment confortables grâce à son cintrage de guidon de 5,5°.

KITS - ALL IN ONE



Lenker-Kits mit 20 mm, 40 mm oder 60 mm Erhöhung als Komplettpaket inkl. Schellen, Erhöhungen und Lenkerrohren

» siehe Seite 5.32

Handlebar kits with 20 mm, 40 mm or 60 mm rise as a complete set including clamps, risers and handlebars

» see page 5.32

Kits guidon bracelet avec rehausseur de 20 mm, 40 mm ou 60 mm. Kit complet comprenant demi-guidons, rehausseurs et bagues de fixation

» voir page 5.32

RACING SPORT



Sportlicher Stummellenker aus hochfestem Aluminium für den Profi mit leicht austauschbaren Lenkrohren

» siehe Seite 5.29

Sports clip-ons made of high strength aluminium for professionals, with easily exchangeable tubes

» see page 5.29

Guidons bracelets en aluminium haute résistance pour les motards exigeants, avec des demi-guidon facilement remplaçables

» voir page 5.29

NEUHEITEN BREMSSCHEIBEN

NOUVEAUTÉS DISQUES DE FREIN NEW PRODUCTS – BRAKE DISCS

High Performance! „SP“ – Bremsscheiben für den Rennsport

Diese neue Bremsscheiben-Linie ist auf die extremen Anforderungen des professionellen Rennsports ausgerichtet. SP-Bremsscheiben widerstehen den höchsten thermischen Belastungen und bieten auch in den extremsten Situationen eine überragende Bremsstabilität. Mit TRW Bremsbelägen in SCR-Mischung stellen SP-Bremsscheiben ein High Performance-Bremsystem für den professionellen Rennsport dar. Siehe Seite 2.06.

High performance! “SP” – brake discs for racing

This new brake disc range is designed for the extreme requirements of professional racing. SP brake discs resist the highest thermal loads and offer outstanding braking stability even in the most extreme situations. Together with TRW SCR- compound brake pads, SP brake discs form a high performance braking system for professional racing. See page 2.06.

Haute performance ! Disques de frein « SP » pour la compétition

Cette nouvelle série de disques de frein est adaptée aux exigences extrêmes de la compétition. Les disques de frein SP résistent aux contraintes thermiques les plus élevées et offrent une excellente stabilité au freinage même dans les situations les plus extrêmes. Avec des plaquettes de frein TRW utilisant un mélange en carbone fritté, les disques de frein SP représentent un système de freinage haute performance pour la compétition. Voir page 2.06.

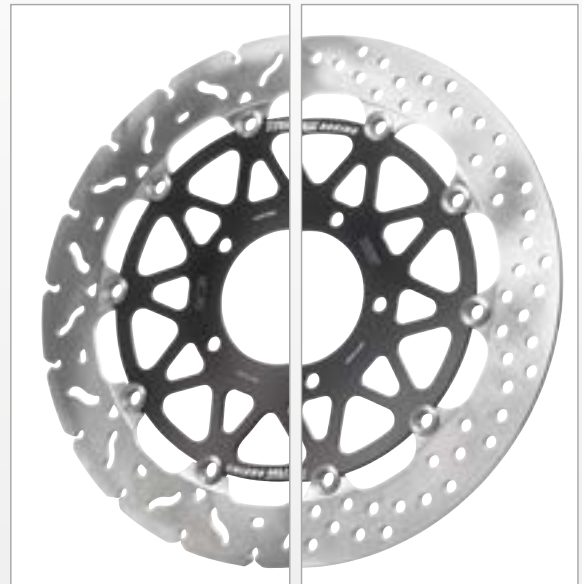

NEUHEITEN KUPPLUNGEN

NOUVEAUTÉS EMBRAYAGES NEW PRODUCTS – CLUTCHES



Racing Kupplung

» noch bessere Hitzebeständigkeit und längere Lebensdauer, ideal für alle High-Performance Anwendungen
» siehe Seite 4.03

Racing clutch

» improved heat resistance and longer service life, ideal for all high performance applications
» see page 4.03

Disques garnis haute performance

» Une meilleure résistance à la chaleur et une plus longue durée de vie, idéal pour toutes les applications haute performance
» voir page 4.03

All-Inclusive-Kupplungs-Superkit

» inkl. Reibscheiben, Stahlzwischen-scheiben, Kupplungsfedern und, falls nötig, Kupplungsdeckeldichtung
» siehe Seite 4.04

All inclusive clutch Superkit

» including friction discs, steel clutch plates, clutch springs and, if required, clutch cover gasket
» see page 4.04

Kit d'embrayage haute performance

» Avec disques garnis, disques lisses en acier, ressorts d'embrayage et, au besoin, joint pour le couvercle d'embrayage
» voir page 4.04



LEIDENSCHAFT ENSTEHT IM ABSOLUTEN
VERTRAUEN
AUF SICHERE UND ZUVERLÄSSIGE
KOMPONENTEN

PASSION IS THE RESULT
OF ABSOLUTE *TRUST*
IN SAFE AND RELIABLE
COMPONENTS

LA PASSION
EST LE FRUIT D'UNE *CONFIANCE* ABSOLUE
DANS DES *COMPOSANTS*
SÛRS ET FIABLES





BREMSBELÄGE

*PLAQUETTES DE FREINS
BRAKE PADS*

Road/ Custom



	Category	Information	Performance	Price	Longlife
MCB... (allround)	Touring, Custom	Sportbikes < 600 ccm			
MCB... SV	Sportbikes, big bikes	keine Einbremszeit nötig no bedding-in required			
MCB... SH	Sportbikes, big bikes	keine Einbremszeit nötig no bedding-in required			
MCB... SV	bei Custom möglich custom only	keine Einbremszeit nötig no bedding-in required			

Scooter



	Category	Information	Performance	Price	Longlife
MCB... (allround)	all Scooters				
MCB... EC	Mini Scooters	< 125 ccm			
MCB... SR	Mini Scooters	< 125 ccm			
MCB... SRM	Mini Scooters	> 125 ccm			

ABE = TÜV approved | TÜV homologué

Racing



SRQ	SINTER	CRQ	CARBON	SCR	SINTER	SH	SINTER
						ABE	

	Category	Information	Performance	Price	Longlife
MCB... SRQ	priv. racing, track days, trainings	< 600 ccm, Super Moto			
MCB... CRQ	race track, professionals	max. Standzeit 6 Std. max. 6 hours' use			
MCB... SCR	race track, professionals	auch für Langstrecke also for endurance			
MCB... SH	road tracks, trainings				

Offroad



ALLROUND	ORGANIC	SI	SINTER	RSI	SINTER	EC	ORGANIC
ABE		ABE				ABE	

	Category	Information	Performance	Price	Longlife
MCB... (allround)	Enduro, Quad	bei trockenen Bedingungen dry conditions			
MCB... SI	Cross, Quad, Enduro	bei jedem Wetter all conditions			
MCB... RSI	Cross, Supercross, Enduro	bei trockenen Bedingungen dry conditions			
MCB... EC	Cross, Quad, Enduro	bei trockenen Bedingungen dry conditions			

= top performance

= lowest price

= longest life

BREMSBELÄGE MIT ABE

PLAQUETTES DE FREIN AVEC TÜV HOMOLOGATION

BRAKE PADS WITH TYPE APPROVAL



ALLROUND ORGANIC

- » bewährte Mischung, vielseitig einsetzbar
- » schwarz lackierte Rückenplatten
- » patentierte NRS- Technologie
- » gute Lebensdauer und Scheibenverträglichkeit
- » *proven compound, versatile use*
- » *backing plates painted black*
- » *patented NRS technology*
- » *good service life and disc compatibility*
- » *alliage éprouvé pour de nombreuses utilisations*
- » *plaques arrière vernies noires*
- » *technologie NRS brevetée*
- » *bonne durée de vie et bonne compatibilité avec les disques*



EC ORGANIC

- » Mischung für Offroad, Roller und niedrig motorisierte Fahrzeuge
- » sehr attraktives Preisniveau
- » optimale Leistung nach Einfahrzeit
- » unter trockenen Bedingungen gute Standzeit auch im Gelände
- » *compound for offroad, scooters and low-power vehicles*
- » *very attractive pricing*
- » *optimum performance after bedding-in period*
- » *high durability under dry conditions*
- » *alliage pour offroad, scooters et véhicules faiblement motorisés*
- » *niveau de prix très attractif*
- » *puissance optimale après le rodage*
- » *bonne durabilité par temps sec, même hors route*



SV/SH SINTER STREET

- » für Hochleistungsmotorräder, anspruchsvolle Tourer und Custom Fahrzeuge
- » ideale Bremskombination von Vorder- zu Hinterachse
- » kurze Einbremsphase
- » *for high-performance motorcycles, sophisticated touring bikers and custom vehicles*
- » *ideal braking combination between front and rear axle*
- » *short bedding-in period*
- » *pour les motos „haute performance“, les motos de tourisme exigeantes et les véhicules Custom*
- » *combinaison de freins idéales entre essieu avant et essieu arrière*
- » *rodage court*

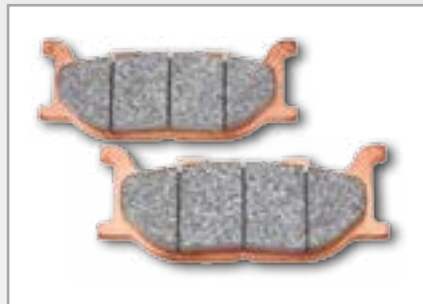

SRM SINTER SCOOTER

- » speziell für größere Roller entwickelt
- » gut dosierbar, hohe Bremsleistung
- » ohne besondere Einbremsphase
- » komfortables Bremsen bei hoher Haltbarkeit
- » *especially developed for larger scooters*
- » *good controllability while high braking performance*
- » *without special bedding-in period*
- » *comfortable braking with great durability*
- » *spécialement développé pour les gros scooters*
- » *bon dosage, capacité de freinage élevée*
- » *aucun rodage particulier*
- » *freinage confortable et durabilité élevée*



SI SINTER OFFROAD

- » hohe Materialfestigkeit auch bei extremen Einsätzen
- » sehr gute Haltbarkeit trotz Sand und Schlamm
- » konzipiert für Moto Cross, Enduro, Quad/ATV
- » *high material strength for extreme conditions*
- » *very good durability even in sand and mud*
- » *designed for Moto Cross, Enduro, Quad/ATV*
- » *grande résistance des matériaux pour des utilisations extrêmes*
- » *très bonne durabilité, même sur le sable et la boue*
- » *conçues pour le Moto Cross, l'Enduro et le Quad/ATV*

BREMSBELÄGE OHNE ABE

PLAQUETTES DE FREIN SANS TÜV HOMOLOGATION

BRAKE PADS WITHOUT TYPE APPROVAL



RSI SINTER OFFROAD

- » professioneller Offroad-Rennsport-Belag
- » überragende Performance
- » thermisch hoch belastbar
- » direktes Ansprechverhalten

- » *professional competitive racing pad*
- » *superior performance*
- » *high thermal resistance*
- » *direct response*



- » *plaquettes de course professionnelles*
- » *performances exceptionnelles*
- » *grande résistance thermique*
- » *capacité de réaction directe*

SRQ SINTER TRACK

- » Sportbelag für Trainings und Super Moto
- » sehr direktes Ansprechverhalten
- » geringe Handkraft notwendig
- » sehr gute Bremsleistung
- » *sports pad for training and Super Moto*
- » *very direct response*
- » *low hand force required*
- » *very good braking performance*
- » *plaquettes sport pour les entraînements et SuperMotos*
- » *capacité de réaction très directe*
- » *force manuelle réduite requise*
- » *très bonne capacité de freinage*

CRQ HYPER-CARBON

- » bewährter Rennbelag auf Carbonbasis
- » NRS Technologie ermöglicht konstanten Druckpunkt bis zur Verschleißgrenze
- » höhere Haltbarkeit gegenüber SRQ
- » *proven racing pad on carbon basis*
- » *NRS technology allows constant pressure point up to the wear limit*
- » *greater durability compared to SRQ*
- » *plaquettes sport éprouvées à base de carbone*
- » *technologie NRS permettant un point de poussée constant jusqu'à la limite d'usure*
- » *durabilité plus élevée que celle des SRQ*

SCR SINTER-CARBON

- » nur für professionelle Einsätze
- » thermische Anpassung notwendig
- » hohe Lebensdauer ohne Aushärtung
- » bevorzugt für extreme Bremsenkurse oder Langstreckenrennen
- » *only for professional use*
- » *thermal adaptation required*
- » *long service life without hardening*
- » *preferred for extreme braking circuits or endurance races*
- » *utilisations professionnelles uniquement*
- » *adaptation thermique requise*
- » *durée de vie élevée sans durcissement*
- » *à privilégier pour les courses de freinage extrêmes ou endurance*



SCHEIBENBREMSBELÄGE

DISC BRAKE PADS

PLAQUETTES DES FREINS

Nut zum Ausgasen und Ableiten von Wasser und Bremsstaub

Groove for air expulsion and draining water and brake dust

Rainure pour l'évacuer les poussières des plaquettes et dissiper les gaz

Kennzahl für die Reibwertkategorie
Code for the friction coefficient category
Code de la catégorie de frottement

Hersteller-Logo
Manufacturer's logo
Logo du fabricant

Trägerplatte
Backing plate
Support métallique

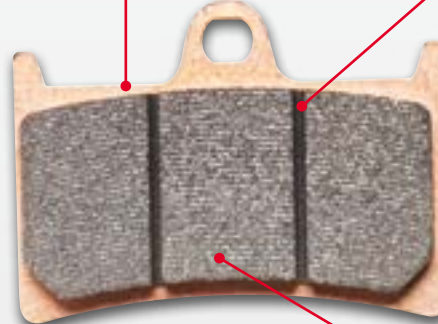

KBA-Nummer = ABE
Homologation code
Code d'homologation

Artikelnummer
Part number
Numéro d'article

Eingestanzter Produktionscode
Punched production code
Code de production unique

Reibbelag (Abb. Sintermetall)
Friction lining (fig. sinter)
Revêtement de friction (sinter)

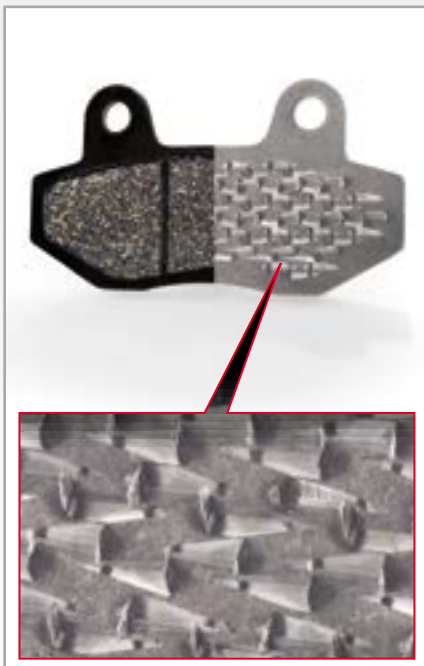

NRS Technologie

Einzigartiges, patentiertes Verfahren zur Aufbringung von Belagmaterial. Die Rückenplatten werden mit einem speziellen Hakenprofil versehen, welches sich unlösbar im Belagmaterial verankert. Damit kann ein Verlust von Belagmaterial unter extremen thermischen Bedingungen ausgeschlossen werden, z. B. im Rennsport, bei Passabfahrten.

NRS Technologie wird zur Herstellung der organischen Allround- und den HyperCarbon-Belägen angewendet.

NRS technology

Unique, patented method for applying lining material. The backing plates feature a special hook profile which is permanently embedded into the lining material. This precludes loss of lining material under extreme thermal conditions, e.g. in competitive racing or during pass descents.

The NRS technology is used in the production of the organic Allround pads and the HyperCarbon pads.

Technologie NRS

Méthode brevetée unique pour l'application du matériau des plaquettes. Les plaques arrières sont dotées de crochets spéciaux adhérant au matériau des plaquettes de manière indissociable. Il est ainsi possible d'exclure toute perte du matériau de la plaquette même dans les conditions thermiques extrêmes, p.ex. pour les sports de course ou sur les trajets de rodage.

La technologie NRS est utilisée pour la production de disques organiques Allround et HyperCarbon.



Option 1

Option 2

Option 3



Option 1

Option 2

Adly (HerChee)

SF	25 Silver Fox				MCB 590	EC			MCS 962		
	50 Cat				MCB 590	EC					
	50 Fox				MCB 590	EC			MCS 962		
AT	50 Air Tech				MCB 519	EC	SR				
NB	50 Nobel				MCB 519	EC	SR				
P	50 Panther				MCB 519	EC	SR		MCS 962		
RT	50 Road Tracer				MCB 590	EC			MCS 962		
SF	50 Silver Fox			00-05	MCB 590	EC			MCS 962		
SF	50 Silver Fox			06-	MCB 519	EC			MCS 962		
SS	50 Super Sonic			00-	MCB 519	EC	SR		MCB 519	EC	SR
TB	50 Thunderbike			97-	MCB 519	EC	SR		MCB 519	EC	SR
	50 Jet			96-	MCB 519	EC	SR		MCS 962		
	100 Cat			01-	MCB 590	EC					
	125 Cat			01-	MCB 590	EC					
SS	125 Super Sonic			01-	MCB 519	EC	SR				
TB	125 Thunderbike	TB-125		99-04	MCB 519	EC	SR		MCB 519	EC	SR
	150 Interceptor			05-	* MCB 519 SI	EC			MCB 519 SI	EC	
ATV	150 Crossover			05-09	* MCB 519 SI	EC			MCB 519 SI	EC	
ATV	150 Crossroad			06-10	* MCB 519 SI	EC			MCB 519 SI	EC	
ATV	150 Sport			04-09	* MCB 519 SI	EC			MCB 519 SI	EC	
ATV	150 Crossroad Sentinel			06-10	* MCB 760 SI				MCB 805 SI		
	280 Canyon		Herkules	07-09	* MCB 760 SI				MCB 805 SI		
	280 Hurricane		Herkules	07-	* MCB 760 SI				MCB 805 SI		
ATV	300			05-06	* MCB 519 SI	EC			MCB 519 SI	EC	
ATV	300 Sport			07-	* MCB 760 SI				MCB 805 SI		
ATV	300 Crossover			05-09	* MCB 760 SI				MCB 805 SI		
ATV	300 Crossroad			05-10	* MCB 760 SI				MCB 805 SI		
ATV	300 Utility			04-09	* MCB 760 SI				MCB 805 SI		
	300 Hurricane XS		Herkules	07-	* MCB 760 SI				MCB 805 SI		
	300 Interceptor		Herkules	07-	* MCB 519 SI	EC			MCB 519 SI	EC	
	320 Canyon, SE		Herkules	07-	* MCB 760 SI				MCB 805 SI		
	320 Hurricane		Herkules	07-	* MCB 760 SI				MCB 805 SI		
	320 Hurricane S Flat		Herkules	07-	* MCB 760 SI				MCB 805 SI		
	400 Hurricane XS		Herkules	13-	* MCB 760 SI				MCB 805 SI		
	500 S Hurricane		Herkules	08-	* MCB 760 SI				MCB 805 SI		

Aeon

	50 Aero			06-	MCB 519	EC	SR				
	50 Nox			06-	MCB 519	EC	SR				
	50 Regal			06-	MCB 519	EC	SR				
	50 Torch			06-	MCB 519	EC	SR				
	100 Nox			06-	MCB 519	EC	SR				
	100 Pulsar			06-	MCB 519	EC	SR				
	125 Co-in			14-	MCB 519	EC	SR				
	125 Elite i			12-	MCB 689	EC			MCB 523		
	125 Nox			06-	MCB 519	EC	SR				
	125 Overland			02-					MCB 615 SI	EC	
	125 Öz			14-	MCB 663	EC					
	125 Pulsar			06-	MCB 519	EC	SR				
	125 Urban i			11-12	MCB 689	EC			MCB 519	EC	
	125 Urban i			13-	MCB 689	EC			MCB 523		
	150 Nox			06-	MCB 519	EC	SR				
	150 Pulsar			06-	MCB 519	EC	SR				
	180 Overland			02-					MCB 615 SI	EC	
	200 Elite i			11-	MCB 689	EC			MCB 519 SI	EC	
	200 Two Hundred			06-	* MCB 519 SI	EC			MCB 519 SI	EC	
	220 Cobra			05-12	* MCB 519 SI	EC			MCB 523 SI		
	300 Overland			06-	* MCB 519 SI	EC			MCB 519 SI	EC	
	320 Cobra			08-	* MCB 519 SI				MCB 582 SI		
	350 Cobra			09-	* MCB 519 SI				MCB 582 SI		
	350 Crossland			11-	* MCB 519 SI				MCB 615 SI		
	350 Elite i			12-	* MCB 689	EC			MCB 519 SI	EC	
	350 Urban i			11-	* MCB 689	EC			MCB 519 SI	EC	



* 2 Sätze erforderlich – 2 sets required
 Parkbremse – Parkingbrake

ohne Verschleißanzeige – without wear indicator
 linke Seite – left side
 rechte Seite – right side



Option 1

Option 2

Option 3



Option 1

Option 2

Aeon

400 Cobra	10-		*	MCB 519 SI				MCB 519 SI	EC	
400 Crossland	12-		*	MCB 519 SI				MCB 582 SI		
600 Overland	11-		*	MCB 760 SI				MCB 523 SI		

Alfer

MC	80	87-		MCB 75				MCB 535	EC	
MC	125	88-		MCB 572				MCB 75		
VRE	125 4-stroke	00-		MCB 648	SI	RSI	EC	MCB 672 SI	RSI	EC
	250 GR Enduro	88-		MCB 572				MCB 75		
MC	250	88-		MCB 572				MCB 75		
VR	250 Enduro	98-05		MCB 648	SI	RSI	EC	MCB 672 SI	RSI	EC
	300 GR Enduro	88-		MCB 572				MCB 75		

Aprilia

	50 Amico GL	HU	93-99	MCB 674	EC	SR		MCS 800		
	50 Amico LX	GC	95-96	MCB 674	EC	SR		MCS 800		
	50 Amico Sport	GC	92-93	MCB 674	EC	SR		MCS 800		
	50 Amico		90-91	MCS 800				MCS 800		
	50 Area 51	MY	98	MCB 674	EC	SR		MCB 674	EC	SR
	50 Area 51	MY	99-02	MCB 696	EC	SR		MCB 696	EC	SR
	50 Classic	GI	95-01	MCB 674	EC	SR		MCS 800		
	50 Compay		09-	MCB 696	EC	SR		MCS 984		
	50 Gulliver AC	LH00	95-00	MCB 674	EC	SR		MCS 800		
	50 Gulliver LC	LH04	96-00	MCB 674	EC	SR		MCS 800		
	50 Habana	PK	98-02	MCB 696	EC	SR		MCS 818		
	50 Habana Custom	PK	98-02	MCB 696	EC	SR		MCS 818		
	50 Mojito Custom	TF	99-	MCB 696	EC	SR		MCS 818		
	50 Pegaso		92-94	MCB 664				MCB 552		
	50 Rally AC	MD0	95-99	MCB 644	EC			MCS 800		
	50 Rally AC	MDH	00-04	MCB 644	EC			MCS 800		
	50 Rally LC	MDA	96-00	MCB 674	EC	SR		MCB 674	EC	SR
	50 Red Rose		88-89	MCB 564	SR					
	50 Red Rose Classic	GI/LP	90-99	MCB 578						
	50 Scarabeo	HS/LE	94-97	MCB 674	EC	SR		MCS 800		
	50 Scarabeo de Lux	PF	98-02	MCB 674	EC	SR		MCB 674	EC	SR
	50 Scarabeo 4T	SC	02-09	MCB 674	EC	SR		MCS 800		
	50 Scarabeo Ditech	SC	02-06	MCB 674	EC	SR		MCB 710	EC	
	50 Scarabeo Street	SC	05-09	MCB 674	EC	SR		MCS 800		
	50 Sonic AC, LC	PB	99-02	MCB 674	EC	SR		MCS 800		
	50 Sonic LC	TL	11-	MCB 674	EC	SR		MCS 800		
	50 Sport City 4T	SB	08-09	MCB 744	EC			MCS 800		
	50 Sport City one 2T	SB	08-11	MCB 744	EC			MCS 800		
	50 Tuareg		-86	MCB 75	SI					
	50 Tuareg		87-	MCB 578				MCB 75		
	50 Tuareg Rally		90-	MCB 578				MCB 552		
	50 Tuono		03-04	MCB 734	EC			MCB 75		
AF1	50 Futura		88-92	MCB 578				MCB 552		
AF1	50 Replica		87	MCB 579				MCB 75		
MX	50	ST	03-05	MCB 664	EC			MCB 552		
RS	50 Extrema, Replica	HP/LM	93-94	MCB 578				MCB 75		
RS	50 Extrema, Replica	MM	95-98	MCB 644	EC			MCB 552		
RS	50 Extrema, Replica	PG	99-01	MCB 664	EC			MCB 552		
RS	50 Extrema, Replica	SE	02-03	MCB 664	EC			MCB 552		
RS	50 Replica	SE	04-05	MCB 664	EC			MCB 552		
RS	50 Replica	PL	06-10	MCB 664	EC			MCB 552		
RS-4	50	TK	11	MCB 780	SV			MCB 535	EC	
RS-4	50	TK	12-	MCB 780	SV			MCB 519	EC	
RX	50	FZ/HB/LR	91-94	MCB 629				MCB 552		
RX	50	MU/ST	95-04	MCB 664	EC			MCB 552		
RX	50	PV	06-	MCB 664	EC			MCB 535	EC	
RX	50 Racing	ST	04-06	MCB 664	EC			MCB 552		
SR	50 AC	LB	93-96	MCB 674	EC	SR		MCS 800		
SR	50 Ditech	RL	00-03	MCB 644	EC			MCB 710	EC	
SR	50 Ditech LC	LC	02-03	MCB 644	EC			MCB 710	EC	
SR	50 Ditech Racing	RL/VF	01-05	MCB 674	EC	SR		MCB 710	EC	
SR	50 Ditech Replica	RL/VF	01-05	MCB 674	EC	SR		MCB 710	EC	



Option 1

Option 2

Option 3



Option 1

Option 2

Aprilia

SR	50 Ditech Street LC	TE	03-05		MCB 674	EC	SR		MCB 710	EC	
SR	50 LC	MR/LC/MZ	93-99		MCB 644	EC			MCS 800		
SR	50 LC	RLA	00-02		MCB 644	EC			MCS 800		
SR	50 Motard	LBMC	12-		MCB 744	SRM	EC		MCS 994		
SR	50 Netscaper	MZ	97-98		MCB 674	EC	SR		MCS 800		
SR	50 R LC	VF	04-		MCB 674	EC	SR		MCB 710	EC	
SR	50 R Ditech Factory	VF	04-		MCB 674	EC	SR		MCB 710	EC	
SR	50 Racing	MZ	97-99		MCB 674	EC	SR		MCB 674	EC	
SR	50 Racing	RL	00-		MCB 674	EC	SR		MCB 710	EC	
SR	50 Replica	MR/LC	96		MCB 674	EC	SR		MCS 800		
SR	50 Replica	MZ	97		MCB 674	EC	SR		MCB 674	EC	SR
SR	50 Sport	RL	00-02		MCB 674	EC	SR		MCB 710	EC	
SR	50 Stealth	MZ	96-00		MCB 674	EC	SR		MCB 674	EC	SR
SR	50 Street	TE	04-		MCB 674	EC	SR		MCB 710	EC	
SR	50 Urban Kid	LB/GP	92-93		MCB 674	EC	SR		MCS 800		
SR	50 www	LY	97-02		MCB 674	EC	SR		MCS 800		
SX	50 SM	PV	06-13		MCB 734	EC			MCB 535	EC	
SX	50 Ltd.		14-		MCB 582 SI				MCB 519 SI	EC	
	100 Scarabeo 4T	RE	00-01		MCB 709	SRM	EC		MCS 994		
	100 Scarabeo 4T	SA/VA	01-09		MCB 709	SRM	EC		MCS 994		
	125 Atlantic	SP	03-11		MCB 726	SRM			MCB 710	SRM	EC
	125 Atlantic i.e.		12-		MCB 726	SRM			MCB 710	SRM	EC
	125 Classic (Red rose)	FQ	90-95		MCB 629				MCB 75		
	125 Classic (Red rose)	MF	96-01		MCB 629						
	125 Compay		09-		MCB 709	SRM	EC		MCS 994		
	125 Habana	PM	99-01		MCB 709	SRM	EC		MCS 994		
	125 Habana Custom	PM	99-01		MCB 709	SRM	EC		MCS 994		
	125 Leonardo	MB	96-98		MCB 708	EC			MCB 696	EC	SR
	125 Leonardo	MB	99-04		MCB 709	SRM	EC		MCB 709	SRM	EC
	125 Leonardo	TB	05-06		MCB 709	SRM	EC		MCB 709	SRM	EC
	125 Mojito	PM/RV	02-04		MCB 709	SRM	EC		MCS 994		
	125 Mojito Custom	PM/RV	02-07		MCB 709	SRM	EC		MCS 994		
	125 Mojito Custom	SZ	08-		MCB 709	SRM	EC		MCS 994		
	125 Pegaso		90-91	Brembo	MCB 629				MCB 517		
	125 Pegaso		92-95	Grimeca	MCB 664				MCB 628		
	125 Scarabeo	PC	99-03		MCB 557	SRM			MCB 710	SRM	EC
	125 Scarabeo	TD	04-06		MCB 726	SRM			MCB 710	SRM	EC
	125 Scarabeo	VR	07-10		MCB 726	SRM			MCB 710	SRM	EC
	125 Sport City	VB	04-08		MCB 557	SRM			MCB 710	SRM	EC
	125 Sport City Cube	VB	08-		MCB 557	SRM			MCB 710	SRM	EC
	125 Sport City One	SG	08-11		MCB 744	SRM	EC		MCS 994		
	125 Tuareg Rally		86-88		MCB 557						
	125 Tuareg Rally	GA	89		MCB 629				MCB 628		
	125 Tuareg Rally	GB/GG	90-92		MCB 618				MCB 519	EC	
	125 Tuareg Wind		88-89		MCB 579	SI			MCB 552		
	125 Tuareg Wind		90-		MCB 629				MCB 628		
AF1	125 Sentesi Replica		88-89		MCB 579				MCB 75		
AF1	125 Futura	FM	89-92		MCB 572	RQ			MCB 75		
ETX	125	PH	98-00		MCB 664				MCB 628		
MX	125	TZ	04-07		MCB 648	SI	RSI	EC	MCB 667 SI		
RS	125 Extrema, Replica	GS	92-94		MCB 572	RQ	SRQ		MCB 775		
RS	125 Extrema, Replica	MP	95-01		MCB 572	RQ	SRQ		MCB 775		
RS	125 Extrema, Replica	SF	02-06		MCB 572	RQ	SRQ		MCB 775		
RS	125 Extrema, Replica	RD	07-09		MCB 785	SV	SRQ		MCB 710		
RS	125 Extrema, Replica	PY	10-12		MCB 785	SV	SRQ		MCB 710		
RS	125 Tuono	SF	03-04		MCB 572	RQ			MCB 75		
RS-4	125	TW	11		MCB 780	SV			MCB 535	EC	
RS-4	125	TW	12		MCB 780	SV			MCB 519	EC	
RX	125		86-89		MCB 557						
RX	125	GF	90-91		MCB 618				MCB 75		
RX	125		92-99		MCB 664				MCB 628		
RX	125	MT	00-01		MCB 648	SI	RSI	EC	MCB 667 SI		
RX	125	RV	08-	AJP	MCB 648	SI	RSI	EC	MCB 765		



* 2 Sätze erforderlich – 2 sets required
Parkbremse – Parkingbrake



ohne Verschleißanzeige – without wear indicator



linke Seite – left side



rechte Seite – right side



Option 1

Option 2

Option 3



Option 1

Option 2

Aprilia											
RX	125	RV	08-	Grimeca	MCB 648	SI	RSI	EC	MCB 523	SI	
SR	125 Max i.e.	M35	11-		MCB 744	SRM	EC		MCB 744	SRM	EC
SR	125 Motard	LB	12-		MCB 744	SRM	EC		MCS 994		
SR	125 Racing	PX125	99-02		MCB 709	SRM	EC		MCS 994		
SX	125	RV	08-		MCB 648	SI	RSI	EC	MCB 657		
	150 Leonardo	MB	97-98		MCB 708	EC			MCB 696	EC	SR
	150 Leonardo	MB	99-06		MCB 709	SRM	EC		MCB 709	SRM	EC
	150 Scarabeo	SD	99-03		MCB 557	SRM			MCB 710	SRM	EC
	150 Scarabeo, GT	TD	04-06		MCB 726	SRM			MCB 710	SRM	EC
SR	150	PX	00-02		MCB 709	SRM	EC		MCS 994		
	200 Atlantic	SP	03-05		MCB 726	SRM			MCB 710	SRM	EC
	200 Scarabeo	SD	02-06		MCB 557	SRM			MCB 710	SRM	EC
	200 Scarabeo	VR	07-09		MCB 726	SRM			MCB 710	SRM	EC
	200 Sport City	VB	04-08		MCB 557	SRM			MCB 710	SRM	EC
	200 Sport City Cube	VB	08-09		MCB 557	SRM			MCB 710	SRM	EC
Trial	240 Climber		89-		MCB 578				MCB 552		
AF1	250 Replica		90-		MCB 572	RQ			MCB 75	RQ	
RS	250	LD	95-96		MCB 540 SV	SRQ	CRQ	CRQ	MCB 75	RQ	
RS	250	LD	97-02	*	MCB 683 SV	SRQ	CRQ	SCR	MCB 75	RQ	
RS	250 Pista		04-	*	MCB 683 SV	SRQ	CRQ	SCR	MCB 75	RQ	
	250 Atlantic	SP	03-06		MCB 726 SRM				MCB 710 SRM		
	250 Atlantic i.e.	SP	07-		MCB 726 SRM				MCB 710 SRM		
	250 Leonardo	PD	99-01	Grimeca	MCB 557 SRM				MCB 710 SRM		
	250 Leonardo	PD	99-04		MCB 709 SRM				MCB 710 SRM		
	250 Scarabeo i.e.	VR	06-10		MCB 726 SRM				MCB 710 SRM		
	250 Sport City Cube	VB	08-09	Grimeca	MCB 557 SRM				MCB 710 SRM		
	250 Sport City ie	VB	06-08	Grimeca	MCB 557 SRM				MCB 710 SRM		
	280 Climber		89-		MCB 578				MCB 552		
	280 Climber		93-96		MCB 535	RQ	EC		MCB 535	EC	
SR	300 Max i.e.	PM35	11-		MCB 744 SRM	EC			MCB 744 SRM	EC	
TX	300 M		86-		MCB 535	RQ	EC				
	300 Atlantic i.e.		10-11		MCB 726 SRM				MCB 710 SRM		
	300 Leonardo	SV	04-06	Grimeca	MCB 557 SRM				MCB 710 SRM		
	300 Scarabeo S	VR	09-10		MCB 726 SRM				MCB 710 SRM		
	300 Sport City Cube i.e.	VB	08-	Grimeca	MCB 557 SRM				MCB 710 SRM		
	300 Sport City Blackline	VB	11-		MCB 557 SRM				MCB 710 SRM		
TX	311 M		86-		MCB 535	RQ	EC		MCB 535	EC	
TXR	312 M		88-		MCB 535	RQ	EC		MCB 535	EC	
	350 Tuareg Wind		87-88		MCB 557				MCB 75		
	350 Tuareg Wind		89		MCB 618				MCB 628		
	350 Tuareg Wind		90-		MCB 618				MCB 523		
ETX	350 AE		86-		MCB 557				MCB 75		
	400 Atlantic Sprint	VL	05-08		MCB 726 SRM				MCB 710 SRM		
	400 Scarabeo i.e.	VR	06-09	Grimeca	MCB 557 SRM				MCB 710 SRM		
MXV	450	VT	09-		MCB 669 SI	RSI	EC		MCB 739 SI	RSI	EC
RXV	450 Enduro	VP	06-		MCB 669 SI	RSI	EC		MCB 739 SI	RSI	EC
SXV	450 Supermoto	VS	05-		MCB 793 RSI	SRQ			MCB 739 RSI		EC
	500 Atlantic	PT	02-05		MCB 557 SRM				MCB 710 SRM		EC
	500 Atlantic	PT	02-05		MCB 749 SRM						
	500 Atlantic Sprint	VL	06-10	*	MCB 726 SRM				MCB 710 SRM		
	500 Scarabeo	VR	02-06	*	MCB 557 SRM				MCB 710 SRM		
	500 Scarabeo ABS	VR	03-06	*	MCB 557 SRM				MCB 710 SRM		
	500 Scarabeo i.e.	VR	07-09	*	MCB 557 SRM				MCB 710 SRM		
	500 Scarabeo light	VR	06	*	MCB 557 SRM				MCB 710 SRM		
RXV	550 Enduro	VP	06-		MCB 669 SI	RSI	EC		MCB 739 SI	RSI	EC
SXV	550 Supermoto	VS	05-		MCB 793 RSI	SRQ			MCB 739 RSI		EC
	600 Pegaso	FP	90-92	Brembo	MCB 618				MCB 519		
	600 Tuareg Wind	EP	86-89		MCB 557				MCB 628		
	600 Tuareg Wind	EP	90-91		MCB 618				MCB 519		EC
ETX	600		86-		MCB 557				MCB 75		
	650 Moto 6.5	MH	95-01		MCB 671	SV			MCB 523		
	650 Pegaso	GA	91-95		MCB 652				MCB 523	SI	
	650 Pegaso	MX	96		MCB 652				MCB 523	SI	
	650 Pegaso	ML	97-00		MCB 671	SV			MCB 523	SI	
	650 Pegaso Garda	ML	99-00		MCB 671	SV			MCB 523	SI	



Option 1

Option 2

Option 3



Option 1

Option 2

Aprilia

	650 Pegaso i.e.	RW	01-04						MCB 671	SV				MCB 672	SH	EC
	650 Pegaso Strada	VD	05-10						MCB 683	SV				MCB 672	SH	EC
	650 Pegaso Factory	VD	07-10						MCB 793 RSI	SRQ				MCB 672	RSI	EC
	650 Pegaso Trail	VD	06-10						MCB 671					MCB 672	RSI	EC
SL	750 Shiver	RA	07-10				*		MCB 785	SV	SRQ			MCB 672	SH	
SL	750 Shiver ABS	RA	10-				*		MCB 785	SV	SRQ			MCB 672	SH	
SL	750 Shiver GT	RA	09-10				*		MCB 785	SV	SRQ			MCB 672	SH	
SL	750 Shiver GT ABS	RA	09-				*		MCB 785	SV	SRQ			MCB 672	SH	
SMV	750 Dorsoduro	SM	08-				*		MCB 785	SV	SRQ			MCB 672	SH	
SMV	750 Dorsoduro ABS	SM	09-				*		MCB 785	SV	SRQ			MCB 672	SH	
SMV	750 Dorsoduro Factory	SM	10-				*		MCB 683	SV	SRQ			MCB 672	SH	
SMV	750 Dorsoduro Factory ABS	SM	10-				*		MCB 683	SV	SRQ			MCB 672	SH	
NA	850 Mana	RC	07-12				*		MCB 785	SV	SRQ			MCB 672	SH	
NA	850 Mana	RC	07-12				P							MCB 832 P		
NA	850 Mana ABS	RC	08-				*		MCB 785	SV	SRQ			MCB 672	SH	
NA	850 Mana ABS	RC	08-				P							MCB 832 P		
NA	850 Mana GT ABS	RC	09-				*		MCB 785	SV	SRQ			MCB 672	SH	
NA	850 Mana GT ABS	RC	09-				P							MCB 832 P		
SRV	850 i.e.	M55	12-				*		MCB 648 SRM					MCB 744 SRM		
SRV	850 i.e.	M55	12-				P							MCB 832P		
SRV	850 ABS	M55	12-				*		MCB 648 SRM					MCB 744 SRM		
SRV	850 ABS	M55	12-				P							MCB 832P		
ETV	1000 CapaNord	PS	01-03				*		MCB 671	SV				MCB 700	SH	
ETV	1000 CapaNord ABS	PS	04-09				*		MCB 671	SV				MCB 700	SH	
RST	1000 Mille Futura	PW	01-04				*		MCB 683	SV	SRQ			MCB 648	SH	
RSV	1000 Mille	ME	98-00				*		MCB 683 SV	SRQ	CRQ	SCR		MCB 700	SH	RQ
RSV	1000 R	ME	00				*		MCB 683 SV	SRQ	CRQ	SCR		MCB 700	SH	RQ
RSV	1000 Mille	RP	01-03			4☐	*		MCB 721 SV	SRQ	CRQ	SCR		MCB 700	SH	RQ
RSV	1000 R	RP	01-03			4☐	*		MCB 721 SV	SRQ	CRQ	SCR		MCB 700	SH	RQ
RSV	1000 R	RR	04-10			4☐	*		MCB 721 SV	SRQ	CRQ	SCR		MCB 700	SH	RQ
RSV	1000 R Factory	RR	04-10			4☐	*		MCB 721 SV	SRQ	CRQ	SCR		MCB 700	SH	RQ
RSV	1000 R Tuono	RP	02-05				*		MCB 683 SV	SRQ	CRQ			MCB 700	SH	RQ
RSV	1000 R Tuono	RR	06-08				*		MCB 683 SV	SRQ	CRQ			MCB 700	SH	RQ
RSV	1000 Tuono R Factory	RP	04-05			4☐	*		MCB 721 SV	SRQ	CRQ			MCB 700	SH	RQ
RSV	1000 Tuono R Factory	RR	06-11			4☐	*		MCB 721 SV	SRQ	CRQ			MCB 700	SH	RQ
RSV4	1000 Factory	RK	10-12				*		MCB 792 SV	SRQ	CRQ	SCR		MCB 700	SH	RQ
RSV4	1000 Factory APRC	RK	11-				*		MCB 792 SV	SRQ	CRQ	SCR		MCB 700	SH	RQ
RSV4	1000 Factory APRC ABS	RK	13-				*		MCB 792 SV	SRQ	CRQ	SCR		MCB 700	SH	RQ
RSV4	1000 R	RK	10				*		MCB 792 SV	SRQ	CRQ	SCR		MCB 700	SH	RQ
RSV4	1000 R APRC	RK	11-				*		MCB 792 SV	SRQ	CRQ	SCR		MCB 700	SH	RQ
RSV4	1000 R APRC ABS	RK	13-				*		MCB 792 SV	SRQ	CRQ	SCR		MCB 700	SH	RQ
RSV4	1000 RR ABS		15-				*		MCB 858 SV	SRQ	CRQ	SCR		MCB 700	SH	RQ
RSV4	1000 RF ABS		15-				*		MCB 858 SV	SRQ	CRQ	SCR		MCB 700	SH	RQ
SL	1000 Falco	PA	00-05				*		MCB 683	SV	SRQ			MCB 700	SH	RQ
V4	1000 R Tuono	TY	11-				*		MCB 683 SV	SRQ	CRQ			MCB 700	SH	RQ
V4	1000 R Tuono APRC	TY	11-				*		MCB 683 SV	SRQ	CRQ			MCB 700	SH	RQ
V4	1000 R Tuono APRC ABS	TY	14-				*		MCB 856 SV	SRQ	CRQ			MCB 700	SH	RQ
V4	1100 RR Tuono ABS		15-				*		MCB 856 SV	SRQ	CRQ			MCB 700	SH	RQ
V4	1100 Tuono Factory ABS		15-				*		MCB 856 SV	SRQ	CRQ			MCB 700	SH	RQ
ETV	1200 CapaNord	VK	13-				*		MCB 856 SV					MCB 672	SH	
ETV	1200 CapaNord ABS	VK	13-				*		MCB 856 SV					MCB 672	SH	
ETV	1200 CapaNord Rally ABS		15-						MCB 856 SV					MCB 672	SH	
SMV	1200 Dorsoduro	TV	11-12				*		MCB 785	SV	SRQ			MCB 672	SH	
SMV	1200 Dorsoduro ATC/ABS	TV	11-				*		MCB 785	SV	SRQ			MCB 672	SH	

Arctic Cat

	50 Y6 Youths 2x4		04-05				*		MCS 843							
	90 2x4 (2T) Youth		02-04											MCB 843		
	90 2x4 (4T) Youth		04-05											MCB 843		
	90 Y12 Youths		02-05				*		MCS 843							
	250 2x4/4x4		05-				*		MCB 773 SI					MCB 773 SI		
	250 2x4/4x4		99-04				*		MCB 763 SI					MCB 763 SI		
	250 DVX		06-09				*		MCB 760 SI					MCB 732 SI		



* 2 Sätze erforderlich – 2 sets required
 Parkbremse – Parkingbrake



ohne Verschleißanzeige – without wear indicator



linke Seite – left side



rechte Seite – right side



Option 1

Option 2

Option 3



Option 1

Option 2

Arctic Cat

	300 2x4/4x4		98-04	*	MCB 763 SI				MCB 763 SI		
	300 4x4		05-	*	MCB 773 SI				MCB 773 SI		
	300 ATV		10-	*	MCB 773 SI				MCB 773 SI		
	300 DVX		09-	*	MCB 760 SI				MCB 732 SI		
	350 ATV		12-	*	MCB 773 SI				MCB 773 SI		
	400 DVX		04-08	*	MCB 561 SI	EC			MCB 626 SI		
	400 FIS		05-	*	MCB 773 SI				MCB 773 SI		
	400 FIS		98-04	*	MCB 763 SI				MCB 763 SI		
TRV	400 , H1		09-	*	MCB 773 SI				MCB 773 SI		
	400 2x4/4x4		05-	*	MCB 773 SI				MCB 773 SI		
	400 2x4/4x4		98-04	*	MCB 763 SI				MCB 763 SI		
	450 H1 EFI, i, iGT		10-	*	MCB 773 SI				MCB 773 SI		
TRV	450 , i		11-	*	MCB 773 SI				MCB 773 SI		
XC	450 i		11-	*	MCB 773 SI				MCB 773 SI		
TBX	500 4x4		02-04	*	MCB 763 SI				MCB 763 SI		
TBX	500 4x4		05-	*	MCB 773 SI				MCB 773 SI		
TRV	500 4x4		03-04	*	MCB 763 SI				MCB 763 SI		
TRV	500 4x4		05-	*	MCB 773 SI				MCB 773 SI		
	500 2x4/4x4		05-	*	MCB 773 SI				MCB 773 SI		
	500 2x4/4x4		98-04	*	MCB 763 SI				MCB 763 SI		
	550 i, i GT, i LTD		11-	*	MCB 773 SI				MCB 773 SI		
	550 Prowler		09-	*	MCB 773 SI				MCB 773 SI		
	550 S, S LTD		10-	*	MCB 773 SI				MCB 773 SI		
TRV	550 EFI, EFI LE, Cruiser, C.i		09-	*	MCB 773 SI				MCB 773 SI		
TRV	550 GT, GT S		10-	*	MCB 773 SI				MCB 773 SI		
	650 Prowler		06-	*	MCB 773 SI				MCB 773 SI		
TRV	650 H1, V2 4x4		05-	*	MCB 773 SI				MCB 773 SI		
	700 Diesel Utility, Super Duty D.		07-	*	MCB 773 SI				MCB 773 SI		
	700 Prowler		08-	*	MCB 773 SI				MCB 773 SI		
	700 S, S LTD		10-	*	MCB 773 SI				MCB 773 SI		
TBX	700 LTD		11-	*	MCB 773 SI				MCB 773 SI		
TRV	700 , Cruiser, H2 Cruiser, GT		09-	*	MCB 773 SI				MCB 773 SI		
	700 Efi 4x4		06-	*	MCB 773 SI				MCB 773 SI		
	700 Mudpro, i Mudpro		09-	*	MCB 773 SI				MCB 773 SI		
	1000 Prowler		09-	*	MCB 773 SI				MCB 773 SI		
	1000 Thundercat H2		08-10	*	MCB 773 SI				MCB 773 SI		
TRV	1000 Cruiser, H2 EFI Cruiser		09-	*	MCB 773 SI				MCB 773 SI		
	1000 H2 EFI, 4x4		08-	*	MCB 773 SI				MCB 773 SI		
	1000 Mudpro, i Mudpro		10-	*	MCB 773 SI				MCB 773 SI		

Atala

	25 Carosello		97-		MCB 644	EC			MCS 921		
AT10	25 Byte		97-		MCB 644	EC			MCS 921		
	50 Carosello		97-		MCB 644	EC			MCS 921		
	50 Skeggia		98-		MCB 644	EC			MCS 921		
AT10	50 Byte		97-		MCB 644	EC			MCS 920		
AT12	50 Hacker		95-		MCB 644	EC			MCS 921		
	125 Hacker		98-		MCB 644	EC			MCS 921		

ATU

GE	50 Spin				MCB 694	EC			MCS 962		
GT	50 Race				MCB 694	EC			MCS 962		

Baotian

BT49	50 Rebel	QT-12	06-11		MCB 590	EC			MCS 800		
BT49	50 Speedy	QT-9	10-		MCB 590	EC			MCS 800		
BT50	50 Retro	QT-11	06-11		MCB 590	EC			MCS 800		
	50 Eco Bike				MCB 590	EC			MCS 800		
BT125	125 T		06-07		MCB 694	EC			MCB 510		

Barossa

XS	125		07-10		MCB 684	EC					
	170 Cheetah		03-06		MCS 962				MCB 519 SI	EC	
	170 Stinger		06-		MCS 962				MCB 582 SI		
	250 Cheetah		03-06		MCS 962				MCB 519 SI	EC	
	300 Bronco	SMC		*	MCB 523SI				MCB 523 SI		



Option 1

Option 2

Option 3



Option 1

Option 2

Beeline

GT	50 Veloce		08-10		MCB 694	EC			MCS 962		
----	-----------	--	-------	--	---------	----	--	--	---------	--	--

Benelli

491	50 Naked	ND	99-04		MCB 674	EC	SR		MCS 800		
491	50 Racing	BA01	99-04		MCB 674	EC	SR		MCB 674	EC	SR
491	50 RR, GP	BA01	00-04		MCB 674	EC	SR		MCB 674	EC	SR
491	50 Sport, GT	BA01	98-04		MCB 674	EC	SR		MCS 800		
491	50 ST	BA01	01-04		MCB 674	EC	SR		MCS 800		
491	50 Superbike	BA01	99-04		MCB 674	EC	SR		MCB 674	EC	SR
	50 Alp		91-		MCB 535	EC			MCB 613		
	50 Chrono		92-93		MCB 578				MCS 800		
	50 Chrono		94-		MCB 674	EC	SR		MCS 800		
	50 Devil		92-		MCB 572	RQ			MCB 564		
	50 KR		86-		MCB 578						
	50 Naked	ND	01-03		MCB 696	EC	SR		MCS 962		
	50 Nemo		94-		MCB 674	EC	SR		MCS 800		
	50 Pepe LX	BA03	99-		MCB 674	EC	SR		MCS 962		
	50 Quadra		94-		MCB 674	EC	SR		MCS 800		
	50 Spring		92-95		MCB 572	RQ			MCB 564	SR	
K2	50 AC	BA01	98-01		MCB 674	EC	SR		MCB 674	EC	SR
K2	50 LC	BA01	99-01		MCB 674	EC	SR		MCB 674	EC	SR
K2	50 Namur	BA01	99-01		MCB 674	EC	SR		MCB 674	EC	SR
	50 Supermotard		07-		MCB 734	EC			MCB 535	EC	
	50 X 49		07-		MCB 694	EC					
	80 Devil		92-		MCB 572	RQ			MCB 564	SR	
LX	100 Pepe	BA03	99-06		MCB 674	EC			MCS 962		
	124 T		83		MCB 75						
	125 Adiva	D1	01-04		MCB 696	EC	SR		MCB 727	SRM	
	125 Macis		10-		MCB 582	EC					
	125 Velvet	M1	99-07		MCB 696	EC	SR		MCB 696	EC	SR
	125 Caffè Nero		08-		MCB 615	SRM			MCB 582	SRM	
	125 Caffè Nero		08-		MCB 582	SRM					
	125 Velvet Touring		08-		MCB 734	EC			MCB 710	EC	SRM
	150 Adiva	D1	00-04		MCB 696	EC	SR		MCB 727	SRM	
	250 Velvet	M7	99-03		MCB 734	EC			MCB 710	EC	SRM
	250 Caffè Nero		08-		MCB 615	SRM			MCB 724		
	250 Caffè Nero		08-		MCB 582	SRM					
	254		83		MCB 508						
BN	302		14-		* MCB 683 SV	SRQ	CRQ		MCB 700	SH	EC
	304		83		MCB 75						
	354		-82		* MCB 75				MCB 19		
	354 Sport		83-		* MCB 75				MCB 75		
	400 Velvet Dusk	VM	03-05		MCB 734	EC			MCB 674	EC	
BX	450 Cross		07-		MCB 648	SI	RSI	EC	MCB 672 SI	RSI	EC
BX	500 Enduro		08-		MCB 648	SI	RSI	EC	MCB 672 SI	RSI	EC
BN	600 GT	P25	13-		* MCB 721 SV	SV	SRQ	CRQ	MCB 700	SH	RQ
BN	600	P25	13-		* MCB 721 SV	SV	SRQ	CRQ	MCB 700	SH	RQ
	654 Sport		83		* MCB 75				MCB 75		
	750 Sei		75-		* MCB 19						
	756 2-UE		07-		4 ☐ * MCB 721 SV	SRQ			MCB 700	SH	RQ
	900 Sei		83		* MCB 19				MCB 533		
	900 Tornado	TB	02		* MCB 683	SV			MCB 75	RQ	
	900 Tornado Tre	TB	03-05		4 ☐ * MCB 721 SV	SRQ	CRQ		MCB 700	SH	RQ
TNT	899 Cafe Racer		10-12		4 ☐ * MCB 721 SV	SRQ			MCB 700	SH	RQ
TNT	899 Sport	TN	07-		* MCB 683	SV	SRQ		MCB 700	SH	RQ
TNT	899 Tornado Naked Tre	TK	07-11		* MCB 683	SV	SRQ		MCB 700	SH	RQ
TReK	899	TK	07-12		* MCB 683	SV	SRQ		MCB 700	SH	RQ
TNT	899 Century Racer	TN	11-12		4 ☐ * MCB 721 SV	SRQ			MCB 700	SH	RQ
TNT	1100		04-		* MCB 683	SV	SRQ	CRQ	MCB 75		
TNT	1130		13-		4 ☐ * MCB 721 SV	SRQ	CRQ		MCB 700	SH	RQ
TNT	1130 Cafe Racer	TN	06-11		4 ☐ * MCB 721 SV	SRQ	CRQ		MCB 700	SH	RQ
TNT	1130 R 160	TN	12		4 ☐ * MCB 721 SV	SRQ	CRQ		MCB 700	SH	RQ
TNT	1130 R	TN	13-		4 ☐ * MCB 721 SV	SRQ	CRQ		MCB 700	SH	RQ



* 2 Sätze erforderlich – 2 sets required
Parkbremse – Parkingbrake



ohne Verschleißanzeige – without wear indicator



linke Seite – left side



rechte Seite – right side



Option 1

Option 2

Option 3



Option 1

Option 2

Benelli

TNT	1130 Sport	TN	05-09	4 ☐ *	MCB 721 SV	SRQ	CRQ		MCB 700	SH	RQ
TNT	1130 Sport Evo	TN	05-09	4 ☐ *	MCB 721 SV	SRQ	CRQ		MCB 700	SH	RQ
TNT	1130 Tornado Naked Tre	TK	06-10	*	MCB 683	SV	SRQ		MCB 700	SH	RQ
TNT	1130 Tornado Tre	TK	06-10	4 ☐ *	MCB 721 SV	SRQ	CRQ		MCB 700	SH	RQ
TReK	1130	TK	06-	*	MCB 683	SV	SRQ	CRQ	MCB 700	SH	RQ
TReK	1130 Amazonas	TK	07-	*	MCB 683	SV			MCB 700	SH	
	1130 Century Racer	TN	11-12	4 ☐ *	MCB 721 SV	SRQ			MCB 700	SH	RQ

Benzhou

YY	50 City Star				MCB 590	EC			MCS 800		
YY	50 Formula 2000				MCB 590	EC			MCS 800		
YY	50 QT				MCB 590	EC			MCS 800		
YY	50 Retro Star				MCB 590	EC			MCS 800		

Beta

	50 Chrono		92-93		MCB 578				MCS 962		
	50 Chrono	KTMG050	94-		MCB 674	EC	SR		MCS 962		
	50 Eikon	BS	99-06		MCB 75	RQ			MCB 710	EC	
	50 Nemo		96-		MCB 674	EC	SR		MCS 962		
	50 Quadra	KTMG050	95-96		MCB 75	RQ			MCS 962		
	50 Quadra	KTMG050	97-00		MCB 674	EC	SR		MCS 962		
	50 Techno		96-		MCB 535	EC	SR		MCB 535	EC	SR
	50 Tempo	KTMG050	97-98		MCB 75	RQ			MCS 800		
	50 Tempo (13" wheel)	KTMG050	00-02		MCB 674	EC	SR				
	50 Tempo (16" wheel)	KTMG050	00-02		MCB 674	EC	SR				
ARK	50 AC	BS	99-01		MCB 674	EC	SR		MCB 674	EC	SR
ARK	50 AC	BS4	02-		MCB 674	EC	SR		MCB 674	EC	SR
ARK	50 LC	BS	99-		MCB 674	EC	SR		MCB 674	EC	SR
RR	50 Enduro		04-07		MCB 734	EC			MCB 535	EC	
RR	50 Enduro		08-		MCB 734	EC			MCB 739 SI		
RR	50 Enduro Factory		12-		MCB 734	EC			MCB 739 SI		
RR	50 Enduro Racing		09-11		MCB 734	EC			MCB 739 SI		
RR	50 Enduro Standard		09-		MCB 535	EC			MCB 739 SI		
RR	50 Standard		05-08		MCB 734	EC			MCB 535	EC	
RR	50 Supermotard		08-		MCB 734				MCB 820		
RR	50 Supermoto/Enduro	BE	99-05		MCB 535	EC			MCB 535	EC	
	80 Evo		09-		MCB 766						
	80 Rev		00-07		MCB 535	EC			MCB 535	EC	
	80 Rev		08-		MCB 766				MCB 852		
	125 Alp 4-stroke		00-05		MCB 535	RQ	EC		MCB 535	RQ	EC
	125 Alp 4-stroke		06-		MCB 734				MCB 820		
	125 Eikon	S7	99-		MCB 75	RQ			MCB 710	EC	SRM
	125 Jonathan		99-		MCB 540	SV			MCB 672	SH	
	125 KR		86-		MCB 75						
	125 TR 33		86		MCB 564						
	125 TR 34		87		MCB 535	RQ	EC		MCB 75		
	125 TR 34		88-		MCB 535	RQ	EC		MCB 613		
	125 TR 35		88-		MCB 535	RQ	EC		MCB 613		
RR	125		06-		MCB 734				MCB 739 SI	RSI	EC
	125 Evo 2T		09-		MCB 766				MCB 851		
	125 Rev 3		06-08		MCB 766				MCB 852		
	125 Rev 3		00-05		MCB 766				MCB 766		
	150 Eikon	S7	00-		MCB 75	RQ			MCB 710	EC	SRM
	200 Alp 4-stroke		00-05		MCB 535	RQ	EC		MCB 535	RQ	EC
	200 Alp 4-stroke		06-		MCB 734				MCB 820		
	200 Urban		08-		MCB 734				MCB 820		
	200 Urban Special		09-		MCB 734				MCB 820		
	200 Evo 2T		09-		MCB 766				MCB 851		
	200 Rev 3		06-08		MCB 766				MCB 852		
	200 Rev 3		00-05		MCB 766				MCB 766		
	240 Alp		91-		MCB 535	RQ	EC		MCB 613		
	240 TR 33		86-		MCB 564						
	250 CR		83-		MCB 75						
	250 Eikon		99-		MCB 75	RQ			MCB 535	EC	
	250 KR		86-		MCB 75	RQ					
RR	250		05-		MCB 669	RSI	SI	EC	MCB 739 SI	RSI	EC



Option 1

Option 2

Option 3



Option 1

Option 2

Beta

	250 Evo 2T/4T		09-		MCB 766				MCB 851		
	250 Rev 3		00-04		MCB 766				MCB 766		
	250 Rev 3 4T		05-08		MCB 766				MCB 852		
	260 Gara		93		MCB 535	RQ	EC		MCB 649		
	260 Techno		94-		MCB 535	RQ	EC		MCB 649		
	260 TR 34		87		MCB 564				MCB 75		
	260 TR 34		88-		MCB 535	RQ	EC		MCB 613		
	260 TR 35		88-		MCB 535	RQ	EC		MCB 613		
	260 Zero		90-92		MCB 535	RQ	EC		MCB 613		
	270 Rev 3		05-08		MCB 766				MCB 852		
	290 Evo 2T		09-		MCB 766				MCB 851		
	300 Crosstrainer		15-		MCB 669	SI	RSI	EC	MCB 739 SI	RSI	EC
	300 Evo 2T/4T		09-		MCB 766				MCB 851		
RR	300		13-		MCB 669	SI	RSI	EC	MCB 739 SI	RSI	EC
	350 Alp 4.0		06-		MCB 734				MCB 820		
	350 Euro		03-		MCB 540	SV			MCB 539	EC	
	350 Jonathan		03-		MCB 540	SV			MCB 539	EC	
RR	350		12-		MCB 669	SI	RSI	EC	MCB 739 SI	RSI	EC
RR	390		15-		MCB 669	SI	RSI	EC	MCB 739 SI	RSI	EC
RR	400		05-		MCB 669	SI	RSI	EC	MCB 739 SI	RSI	EC
RR	430		15-		MCB 669	SI	RSI	EC	MCB 739 SI	RSI	EC
RR	450		05-		MCB 669	SI	RSI	EC	MCB 739 SI	RSI	EC
RR	450		12-		MCB 669	SI	RSI	EC	MCB 739 SI	RSI	EC
RR	480		15-		MCB 669	SI	RSI	EC	MCB 739 SI	RSI	EC
RR	498		12-		MCB 669	SI	RSI	EC	MCB 739 SI	RSI	EC
RR	520		10-11		MCB 669	SI	RSI	EC	MCB 739 SI	RSI	EC
RR	525		05-09		MCB 669	SI	RSI	EC	MCB 739 SI	RSI	EC

Bimota

BBX	300 Enduro		12-		MCB 669	SI	RSI	EC	MCB 739 SI	RSI	EC
YB7	400		89	*	MCB 540 SV	SRQ	CRQ		MCB 75	RQ	
	500 V-Due		97-	*	MCB 540 SV	SRQ	CRQ		MCB 75	RQ	
BBX	508 Enduro		12-		MCB 669	SI	RSI	EC	MCB 575 SI	RSI	EC
YB9	600 SRI		96-97	*	MCB 540 SV	SRQ	CRQ		MCB 75	RQ	
YB9	600 Supersport		94-95	*	MCB 540 SV	SRQ	CRQ		MCB 75	RQ	
BB1	650 Supermono	BB1	94-97	*	MCB 540 SV	SRQ	CRQ		MCB 75	RQ	
BB4	650 Supermono	BB4	98-	*	MCB 683 SV	SRQ	CRQ		MCB 75	RQ	
SB7	750	SB7	94-	*	MCB 540 SV	SRQ	CRQ		MCB 75	RQ	
YB7	750		89	*	MCB 540 SV	SRQ	CRQ		MCB 75	RQ	
	851 Tesi	T1D	91-	*	MCB 540 SV	SRQ	CRQ		MCB 75	RQ	
DB2	900	DB2	93-	*	MCB 540 SV	SRQ	CRQ		MCB 75	RQ	
DB2	900 Editione finale	DB2	97-	*	MCB 540 SV	SRQ	CRQ		MCB 75	RQ	
DB2	900 H.F.	DB2	94-	*	MCB 540 SV	SRQ	CRQ		MCB 75	RQ	
DB2	900 SR	DB2	94-	*	MCB 540 SV	SRQ	CRQ		MCB 75	RQ	
DB3	900 Mantra	DB3	94-01	*	MCB 540 SV	SRQ	CRQ		MCB 75	RQ	
DB4	900 i. e.	DB4	99-	*	MCB 683 SV	SRQ	CRQ		MCB 75	RQ	
Tesi	906 1 D, Editione		91-	*	MCB 540 SV	SRQ	CRQ		MCB 75	RQ	
SB3	997 D	SB3	83-	*	MCB 19	RQ			MCB 75	RQ	
BB3	1000		14-	*	MCB 858 SV	SRQ	CRQ	SCR	MCB 700	SH	RQ
DB5	1000 E, RE		13-	4☐ *	MCB 721 SV	SRQ	CRQ	SCR	MCB 700	SH	RQ
DB5	1000 S, R		07-12	4☐ *	MCB 721 SV	SRQ	CRQ	SCR	MCB 700	SH	RQ
DB6	1000 Delirio	DB06	07-	4☐ *	MCB 721 SV	SRQ	CRQ	SCR	MCB 700	SH	RQ
SB8	1000	SB8	98-	*	MCB 683 SV	SRQ	CRQ		MCB 75	RQ	
SB8K	1000 Santamonica		07-	4☐ *	MCB 721 SV	SRQ	CRQ	SCR	MCB 75	RQ	
SB8K	1000		06-	*	MCB 683 SV	SRQ	CRQ		MCB 75	RQ	
SB8R	1000	SB8R	99-01	*	MCB 683 SV	SRQ	CRQ		MCB 75	RQ	
YB10	1000 Dieci Biposto		90-	*	MCB 540 SV	SRQ	CRQ		MCB 75	RQ	
YB11	1000		96-01	*	MCB 540 SV	SRQ	CRQ		MCB 75	RQ	
YB6	1000		89	*	MCB 540 SV	SRQ	CRQ		MCB 75	RQ	
YB8	1000 Evolutione		90-95	*	MCB 540 SV	SRQ	CRQ		MCB 75	RQ	
YB8	1000 Furano		92-95	*	MCB 540 SV	SRQ	CRQ		MCB 75	RQ	
DB10	1100 Bimotard		12-	4☐ *	MCB 721 SV	SRQ	CRQ		MCB 700	SH	RQ
DB5	1100 RE		12-	4☐ *	MCB 721 SV	SRQ	CRQ		MCB 700	SH	RQ



* 2 Sätze erforderlich – 2 sets required
Parkbremse – Parkingbrake



ohne Verschleißanzeige – without wear indicator



linke Seite – left side



rechte Seite – right side



Option 1

Option 2

Option 3



Option 1

Option 2

Bimota

DB7	1100	DB07	08-		4 ☐ *	MCB 858 SV	SRQ	CRQ	SCR	MCB 700	SH	RQ
DBX	1100		13-		*	MCB 671 SV				MCB 648 SH	SI	RSI
SB6R	1100	SB6R	00-		*	MCB 683 SV	SRQ	CRQ		MCB 75	RQ	
SB6R	1100	SB6R	91-99		*	MCB 540 SV	SRQ	CRQ		MCB 75	RQ	
	1100 Tesi 3D, Evo, Naked		09-		4 ☐ *	MCB 721 SV	SRQ	CRQ		MCB 700	SH	RQ
DB11	1200	DB11	13-		*	MCB 858 SV	SRQ	CRQ	SCR	MCB 700	SH	RQ
DB12	1200 T		12		4 ☐ *	MCB 721 SV	SRQ	CRQ	SCR	MCB 700	SH	RQ
DB8	1200	DB08	10-		*	MCB 858 SV	SRQ	CRQ	SCR	MCB 700	SH	RQ
DB9	1200 Brivido, C, S		12-		4 ☐ *	MCB 721 SV	SRQ	CRQ	SCR	MCB 700	SH	RQ

BMW

C	Evolution Electric		14-		*	MCB 598 SRM				MCB 598 SRM		
C	Evolution Electric		14-		Ⓟ					MCB 832 P		
C1	125	C1	00-03			MCB 671	SV			MCB 672	SH	
C1	200	C1	00-03			MCB 671	SV			MCB 672	SH	
G	450 SMR		09-		4 ☐ *	MCB 721 SV	SRQ	CRQ	SCR	MCB 743 SI	RSI	EC
G	450 X	E45X	08-			MCB 648	SV	SI	EC	MCB 743 SI	RSI	EC
R45	450	248	78-80		*	MCB 95				MCS 940		
R45	450	248	81-85			MCB 19				MCS 941		
R50	500		-75							MCS 940		
C	600 Sport ABS	C65	11-		*	MCB 598 SRM				MCB 598 SRM		
C	600 Sport ABS	C65	11-		Ⓟ					MCB 832 P		
R60	600 /6		-75							MCS 940		
R60	600 S		-75							MCS 940		
C	650 GT ABS	C65	11-		*	MCB 598 SRM				MCB 598 SRM		
C	650 GT ABS	C65	11-		Ⓟ					MCB 832 P		
F650	650	169	93-99			MCB 671	SV			MCB 672	SH	
F650	650 CS Scarver	K14	00-05			MCB 671	SV			MCB 672	SH	
F650	650 CS Scarver	E650C	03-06			MCB 671	SV			MCB 672	SH	
F650	650 CS Scarver ABS	K14	00-05			MCB 671	SV			MCB 672	SH	
F650	650 CS Scarver ABS	E650C	03-06			MCB 671	SV			MCB 672	SH	
F650	650 GS	R13	00-03			MCB 671	SV			MCB 672	SH	
F650	650 GS	E650G	04-08			MCB 671	SV			MCB 672	SH	
F650	650 GS ABS	R13	00-03			MCB 671	SV			MCB 672	SH	
F650	650 GS ABS	E650G	04-08			MCB 671	SV			MCB 672	SH	
F650	650 GS Dakar	R13	00-03			MCB 671	SV			MCB 672	SH	
F650	650 GS Dakar	E650G	04-08			MCB 671	SV			MCB 672	SH	
F650	650 GS Dakar ABS	R13	00-03			MCB 671	SV			MCB 672	SH	
F650	650 GS Dakar ABS	E650G	04-08			MCB 671	SV			MCB 672	SH	
F650	650 ST	169	97-99			MCB 671	SV			MCB 672	SH	
G	650 GS	E650G	08-			MCB 671	SV			MCB 672	SH	
G	650 GS ABS	E650G	08-			MCB 671	SV			MCB 672	SH	
G	650 GS Sertao	E650G	10-			MCB 671	SV			MCB 672	SH	
G	650 GS Sertao ABS	E650G	10-			MCB 671	SV			MCB 672	SH	
G	650 Xchallenge	E65X	07-10			MCB 671	SV			MCB 672	SH	
G	650 Xchallenge ABS	E65X	07-10			MCB 671	SV			MCB 672	SH	
G	650 Xcountry	E65X	08-09			MCB 671	SV			MCB 672	SH	
G	650 Xcountry ABS	E65X	08-09			MCB 671	SV			MCB 672	SH	
G	650 Xmoto	E65X	07-10			MCB 683	SV	SRQ	CRQ	MCB 672	SH	
G	650 Xmoto ABS	E65X	07-10			MCB 683	SV	SRQ	CRQ	MCB 672	SH	
R	650 GS	247	87-92			MCB 19	SV			MCS 941		
R	650 LS	248	81-86			MCB 19						
R65	650		76-78			MCB 17				MCS 940		
R65	650	248	78-80			MCB 95				MCS 940		
R65	650		81-89		*	MCB 19				MCS 941		
R65	650		89-95			MCB 617	SV			MCS 941		
K75	750	75(K569)	84		*	MCB 19	SV					
K75	750 /2	75(K569)	9/88-96		*	MCB 617	SV			MCS 943		
K75	750 C	75(K569)	85-90		*	MCB 19				MCS 941		
K75	750 RT	75(K569)	89-96		*	MCB 617	SV			MCB 19		
K75	750 S	75(K569)	85-8/88		*	MCB 19				MCB 19		
K75	750 S, ABS	75(K569)	9/88-95		*	MCB 617	SV			MCB 19		
R75	750 /5		-74			MCS 944				MCS 940		
R75	750 /6	R75/6	74-80			MCB 17				MCS 940		
R75	750 /7	R75/7	74-80			MCB 17				MCS 940		



Option 1

Option 2

Option 3



Option 1

Option 2

BMW

F650	800 GS	E8GS	08-12		MCB 671	SV			MCB 672	SH
F650	800 GS ABS	E8GS	08-12		MCB 671	SV			MCB 672	SH
F700	800 GS ABS	E8GS	13-	*	MCB 671	SV			MCB 672	SH
F800	800 GS	E8GS	08-12	*	MCB 671	SV			MCB 672	SH
F800	800 GS ABS	E8GS	08-	*	MCB 671	SV			MCB 672	SH
F800	800 GS Adventure ABS	E8GS	13-	*	MCB 671	SV			MCB 672	SH
F800	800 GT ABS	E8ST	13-	*	MCB 683	SV	SRQ		MCB 672	SH
F800	800 R	E8ST	09-14	*	MCB 683	SV	SRQ		MCB 672	SH
F800	800 R ABS	E8ST	09-14	*	MCB 683	SV	SRQ		MCB 672	SH
F800	800 R ABS		15-	*	MCB 856 SV				MCB 672	SH
F800	800 S, ST	E8ST	06-12	*	MCB 683	SV			MCB 672	SH
F800	800 S ABS, ST ABS	E8ST	06-12	*	MCB 683	SV	SRQ		MCB 672	SH
R80	800	247	85-8/88	*	MCB 19				MCS 941	
R80	800	247	9/89-		MCB 617	SV			MCS 945	
R80	800 /7	247	-81		MCB 17				MCS 940	
R80	800 /7	247	81-84	*	MCB 19				MCS 941	
R80	800 G/S	247E	81-87		MCB 19	SV			MCS 941	
R80	800 GS, GS Paris Dakar	247E	88-95		MCB 533	SV			MCS 941	
R80	800 R	247	93-		MCB 621	SV			MCS 945	
R80	800 RT	247	83-88	*	MCB 19				MCS 941	
R80	800 RT	247	89-95	*	MCB 617	SV			MCS 943	
R80	800 ST	247E	81-84	*	MCB 19				MCS 941	
R	850 C	259C	97-01	*	MCB 680	SV			MCB 707	SH
R	850 C ABS	259C	97-01	*	MCB 680	SV			MCB 707	SH
R	850 GS	259	97-99	*	MCB 680	SV			MCB 707	SH
R	850 GS ABS	259	97-99	*	MCB 680	SV			MCB 707	SH
R	850 GS	R21	99-00	*	MCB 680	SV			MCB 707	SH
R	850 GS ABS	R21	99-00	*	MCB 680	SV			MCB 707	SH
R	850 R	259	95-00	*	MCB 680	SV			MCB 707	SH
R	850 R ABS	259	95-00	*	MCB 680	SV			MCB 707	SH
R	850 R	R21	00-03	*	MCB 736	SV			MCB 707	SH
R	850 R ABS	R21	00-03	*	MCB 736	SV			MCB 707	SH
R	850 R	R11R	04-07	*	MCB 736	SV			MCB 707	SH
R	850 R ABS	R11R	04-07	*	MCB 736	SV			MCB 707	SH
R	850 RT	259	95-01	*	MCB 680	SV			MCB 672	SH
R	850 RT Integral ABS	R22	01-06	*	MCB 748	SV			MCB 707	SH
R90	900 /6	R90/6	73-76	*	MCB 17				MCS 940	
R90	900 S	R90/S	73-76	*	MCB 17				MCS 940	
HP4	1000 RR Race-ABS	K10	13-	*	MCB 858 SV	SRQ	CRQ	SCR	MCB 672	SH
K	1000		82-9/88	*	MCB 19				MCB 19	
K	1000 /2		87-8/88	*	MCB 19				MCB 19	
K	1000 /2		9/88-90	*	MCB 617	SV			MCB 19	
K	1000 LT		86-8/88	*	MCB 19				MCB 19	
K	1000 LT		9/88-91	*	MCB 617	SV			MCB 19	
K	1000 RS		10/88-89	*	MCB 617	SV			MCB 19	
K	1000 RS		83-9/88	*	MCB 19				MCB 19	
K	1000 RS (16V)	100	89-92	*	MCB 680	SV			MCB 19	
K	1000 RS (16V) ABS	100	89-92	*	MCB 680	SV			MCB 19	
K	1000 RT		10/88-89	*	MCB 617	SV			MCB 19	
K	1000 RT		83-9/88	*	MCB 19				MCB 19	
K1	1000	100	88-93	*	MCB 680	SV			MCB 19	
K1	1000 ABS	100	88-93	*	MCB 680	SV			MCB 19	
R	1000 GS		86-94		MCB 533	SV			MCS 945	
R	1000 GS	247E	89-96		MCB 533	SV			MCS 945	
R	1000 R	247	92-95	*	MCB 680	SV			MCS 945	
R	1000 R Mystic	247	94-95	*	MCB 680	SV			MCS 945	
R	1000 RS		76-9/80	*	MCB 17				MCS 940	
R	1000 RS	247	81-84	*	MCB 19				MCB 19	
R	1000 RS	247	86-8/88	*	MCB 19				MCS 941	
R	1000 RS	247	9/88-8/89	*	MCB 617				MCS 941	
R	1000 RS	247	9/89-92	*	MCB 617				MCS 945	
R	1000 RT	247	08/89-95	*	MCB 617	SV			MCS 945	
R	1000 RT		78-80	*	MCB 17				MCS 940	



* 2 Sätze erforderlich – 2 sets required
Parkbremse – Parkingbrake



ohne Verschleißanzeige – without wear indicator
linke Seite – left side
rechte Seite – right side



Option 1

Option 2

Option 3



Option 1

Option 2

BMW

R	1000 RT	247	81-84		*	MCB 19				MCB 19		
R	1000 RT	247	87-8/88		*	MCB 19				MCS 941		
R	1000 RT	247	9/88-8/89		*	MCB 617	SV			MCS 941		
R	1000 S	247	76-8/80		*	MCB 17				MCS 940		
R	1000 S	247	9/80-		*	MCB 19				MCB 19		
R	1000 T		76-80		*	MCB 17				MCS 940		
R	1000 T		9/80-84		*	MCB 19				MCS 941		
R100	1000		76-77			MCB 17				MCS 945		
R100	1000 /7	247	77-80		*	MCB 17				MCS 940		
R100	1000 CS	247	80-84		*	MCB 19	SV			MCB 19		
S	1000 RR	K10	09-		4☐*	MCB 829 SV	SRQ	CRQ	SCR	MCB 672	SH	
S	1000 RR ABS	K10	09-		4☐*	MCB 829 SV	SRQ	CRQ	SCR	MCB 672	SH	
S	1000 R ABS	K10	14-		4☐*	MCB 829 SV	SRQ	CRQ	SCR	MCB 672	SH	
S	1000 XR ABS		15-		*	MCB 856 SV	SRQ			MCB 648	SH	
K	1100 LT	100	90-99		*	MCB 621	SV			MCB 19		
K	1100 LT ABS	100	90-99		*	MCB 621	SV			MCB 19		
K	1100 RS	100	92-96		*	MCB 621	SV			MCB 19		
R	1100 GS	259	93-99		*	MCB 680	SV			MCB 707	SH	
R	1100 GS ABS	259	93-99		*	MCB 680	SV			MCB 707	SH	
R	1100 R	259R	95-01		*	MCB 680	SV			MCB 707	SH	
R	1100 R ABS	259R	98-01		*	MCB 680	SV			MCB 707	SH	
R	1100 RS	259	92-01		*	MCB 680	SV			MCB 19		
R	1100 RS ABS	259	98-01		*	MCB 680	SV			MCB 19		
R	1100 RT	259	94-01		*	MCB 680	SV			MCB 707	SH	
R	1100 S	R2S	98-11/00		*	MCB 680	SV			MCB 707	SH	
R	1100 S ABS	R2S	98-11/00		*	MCB 680	SV			MCB 707	SH	
R	1100 S	R2S	12/00-03	Tokico	*	MCB 736	SV			MCB 707	SH	
R	1100 S	R11S	04-05	Tokico	*	MCB 736	SV			MCB 707	SH	
R	1100 S Integral ABS	R2S	12/00-03	Brembo	*	MCB 748	SV			MCB 707	SH	
R	1100 S Integral ABS	R11S	04-05	Brembo	*	MCB 748	SV			MCB 707	SH	
R	1100 ST		03-06		*	MCB 680	SV			MCB 617		
R	1150 GS	R21	99-11/01		*	MCB 680	SV			MCB 707	SH	
R	1150 GS Evo ABS	R21	99-11/01		*	MCB 680	SV			MCB 707	SH	
R	1150 GS	R21	12/01-04	Brembo	*	MCB 748	SV			MCB 707	SH	
R	1150 GS ABS	R21	12/01-04	Brembo	*	MCB 748	SV			MCB 707	SH	
R	1150 GS Adventure	R21	09/02-03	Brembo	*	MCB 748	SV			MCB 707	SH	
R	1150 GS Adventure ABS	R21	09/02-03	Tokico	*	MCB 736	SV			MCB 707	SH	
R	1150 GS Adventure	R11R	04-05	Brembo	*	MCB 748	SV			MCB 707	SH	
R	1150 GS Adventure ABS	R11R	04-05	Tokico	*	MCB 736	SV			MCB 707	SH	
R	1150 R	R21	01-03	Tokico	*	MCB 736	SV			MCB 707	SH	
R	1150 R ABS	R21	01-03	Tokico	*	MCB 736	SV			MCB 707	SH	
R	1150 R	R11R	04-06	Tokico	*	MCB 736	SV			MCB 707	SH	
R	1150 R ABS	R11R	04-06	Tokico	*	MCB 736	SV			MCB 707	SH	
R	1150 RS	R22	01-03	Tokico	*	MCB 736	SV			MCB 707	SH	
R	1150 RS ABS	R22	01-03	Tokico	*	MCB 736	SV			MCB 707	SH	
R	1150 RS	R11RT	04-05	Tokico	*	MCB 736	SV			MCB 707	SH	
R	1150 RS ABS	R11RT	04-05	Tokico	*	MCB 736	SV			MCB 707	SH	
R	1150 RT Integral ABS	R22	00-03	Brembo	*	MCB 748	SV			MCB 707	SH	
R	1150 RT Integral ABS	R11RT	04-06	Brembo	*	MCB 748	SV			MCB 707	SH	
K	1200 GT Integral ABS	K12	03-05	Brembo	*	MCB 748	SV			MCB 19		
K	1200 GT Teilintegral ABS	K12S	06-08		*	MCB 748	SV			MCB 707	SH	
K	1200 LT ABS	589	98-10/00		*	MCB 680	SV			MCB 713		
K	1200 LT Integral ABS	K2LT	11/00-09	Tokico	*	MCB 736	SV			MCB 713		
K	1200 R	K12R	05-08	Tokico	*	MCB 736	SV			MCB 707	SH	
K	1200 R ABS	K12R	05-08	Tokico	*	MCB 736	SV			MCB 707	SH	
K	1200 R Sport	K12R	07-08	Tokico	*	MCB 736	SV			MCB 707	SH	
K	1200 R Sport ABS	K12R	07-08	Tokico	*	MCB 736	SV			MCB 707	SH	
K	1200 RS ABS	589	96-00		*	MCB 680	SV			MCB 19		
K	1200 RS Integral ABS	K12	01-05	Brembo	*	MCB 748	SV			MCB 19		
K	1200 S Integral ABS	K12S	03-06	Brembo	*	MCB 748	SV			MCB 707	SH	
K	1200 S	K12S	06-08	Brembo	*	MCB 748	SV			MCB 707	SH	
K	1200 S ABS	K12S	06-08	Brembo	*	MCB 748	SV			MCB 707	SH	
R	1200 C	259C	97-02		*	MCB 680	SV			MCB 707	SH	
R	1200 C ABS	259C	97-02		*	MCB 680	SV			MCB 707	SH	
R	1200 C	R2C	03-05	Tokico	*	MCB 736	SV			MCB 707	SH	



Option 1

Option 2

Option 3



Option 1

Option 2

BMW

R	1200 C ABS	R2C	03-05	Tokico	*	MCB 736	SV			MCB 707	SH
R	1200 CL	R2C	03-05	Tokico	*	MCB 736	SV			MCB 707	SH
R	1200 CL ABS	R2C	03-05	Tokico	*	MCB 736	SV			MCB 707	SH
R	1200 GS	R12	04-12	Brembo	*	MCB 748	SV			MCB 707	SH
R	1200 GS ABS	R12	04-12	Brembo	*	MCB 748	SV			MCB 707	SH
R	1200 GS Adventure	R12	06-12	Brembo	*	MCB 748	SV			MCB 707	SH
R	1200 GS Adventure ABS	R12	06-12	Brembo	*	MCB 748	SV			MCB 707	SH
R	1200 GS ABS	R12W	13-		*	MCB 856 SV				MCB 671	SH
R	1200 GS Adventure ABS	R12W	13-		*	MCB 856 SV				MCB 671	SH
R	1200 HP2 Enduro	RHP2	04-06			MCB 671	SV			MCB 648	SH
R	1200 HP2 Megamoto	RHP2	07-08	Brembo	*	MCB 748	SV			MCB 707	SH
R	1200 HP2 Sport	RHP2	08-10		*	MCB 858 SV	SRQ	CRQ	SCR	MCB 648	SH
R	1200 HP2 Sport ABS	RHP2	08-10		*	MCB 858 SV	SRQ	CRQ	SCR	MCB 648	SH
R	1200 nine T ABS	R1ST	14-		*	MCB 856 SV				MCB 648	SH
R	1200 R	R1ST	06-12	Tokico	*	MCB 736	SV			MCB 707	SH
R	1200 R ABS	R1ST	06-14	Tokico	*	MCB 736	SV			MCB 707	SH
R	1200 R ABS		15-		*	MCB 856 SV	SRQ			MCB 671	SH
R	1200 RS ABS		15-		*	MCB 856 SV	SRQ			MCB 671	SH
R	1200 RT ABS	R12T	03-13	Brembo	*	MCB 748	SV			MCB 707	SH
R	1200 RT ABS	R12WT	14-		*	MCB 856 SV				MCB 671 SH	
R	1200 S	R12S	06-08	Brembo	*	MCB 748	SV			MCB 707	SH
R	1200 S ABS	R12S	06-08	Brembo	*	MCB 748	SV			MCB 707	SH
R	1200 ST	R1ST	05-08	Brembo	*	MCB 748	SV			MCB 707	SH
R	1200 ST ABS	R1ST	05-08	Brembo	*	MCB 748	SV			MCB 707	SH
K	1300 GT ABS	K12S	09-11	Brembo	*	MCB 748	SV			MCB 648	SH
K	1300 R	K12S	09-	Tokico	*	MCB 736	SV			MCB 707	SH
K	1300 R ABS	K12S	09-	Tokico	*	MCB 736	SV			MCB 707	SH
K	1300 S ABS	K12S	09-	Brembo	*	MCB 748	SV			MCB 648	SH
K	1600 GT ABS	K16GT	11-	Tokico	*	MCB 736	SV			MCB 671	SH
K	1600 GTL ABS	K16GT	11-	Tokico	*	MCB 736	SV			MCB 671	SH

Bombardier

	50 Quest		03-04			MCS 832				MCS 819	
DS	50		02-04			MCS 832				MCS 819	
	90 Quest		03-04			MCS 832				MCS 819	
DS	90		02-04			MCS 832				MCS 819	
	200 Rally 2x4		03-		*	MCB 519 SI					
DS	250		06-		☞	MCB 724 SI					
DS	250		06-		☞	MCB 723 SI				MCB 724 SI	
	330 Outlander		03-		☞	MCB 724 SI					
	330 Outlander		03-		☞	MCB 723 SI				MCB 724 SI	
	400 Outlander		03-06		☞	MCB 724 SI					
	400 Outlander		03-06		☞	MCB 723 SI				MCB 724 SI	
	500 Quest		02-		☞	MCB 724 SI					
	500 Quest		02-		☞	MCB 723 SI				MCB 724 SI	
	500 Traxter	Traxter	99-00		*	MCB 700				MCB 700	
	500 Traxter		01-06		☞	MCB 724 SI					
	500 Traxter		01-06		☞	MCB 723 SI				MCB 724 SI	
	500 Traxter Max		01-06		☞	MCB 724 SI					
	500 Traxter Max		01-06		☞	MCB 723 SI				MCB 724 SI	
	650 Quest		02-		☞	MCB 724 SI					
	650 Quest		02-		☞	MCB 723 SI				MCB 724 SI	
	650 Quest Max				☞	MCB 724 SI					
	650 Quest Max				☞	MCB 723 SI				MCB 724 SI	
	650 Traxter Max		03-05		☞	MCB 724 SI					
	650 Traxter Max		03-05		☞	MCB 723 SI				MCB 724 SI	
DS	650	A	01-06		☞	MCB 724 SI					
DS	650	A	01-06		☞	MCB 723 SI				MCB 724 SI	
	800 Outlander		06-		☞	MCB 724 SI					
	800 Outlander		06-		☞	MCB 723 SI				MCB 724 SI	



* 2 Sätze erforderlich – 2 sets required
 P Parkbremse – Parkingbrake

☞ ohne Verschleißanzeige – without wear indicator
 ☞ linke Seite – left side
 ☞ rechte Seite – right side



Option 1

Option 2

Option 3



Option 1

Option 2

Cagiva

WRK	250		87-88		MCB 75	SI				
WRK	250		89-		MCB 579	SI				
WRK	260		87-88		MCB 75	SI				
WRK	260		89-		MCB 579	SI				
	350 Elefant		86-		MCB 563			MCB 75	SI	
W12	350		92		MCB 618			MCB 75		
	500 Canyon	5G1	99-01		MCB 582	SI		MCB 615	SI	EC
	600 Canyon	5G	96-		MCB 624	SV		MCB 604		
	600 River	3G	94-	*	MCB 540	SV		MCB 75	SI	
W16	600	2G	94-96		MCB 618			MCB 523		
	650 Elefant		86-		MCB 563			MCB 75	SI	
	650 Raptor	M2	01-	*	MCB 683	SV		MCB 700		
	650 V-Raptor		01-	*	MCB 683	SV		MCB 700		
	750 Elefant	B	88-		MCB 75	SI		MCB 75	SI	
	750 Elefant	B	90-97		MCB 563			MCB 618		
	750 Lucky Explorer		88		MCB 563			MCB 75	SI	
	900 Canyon	5G	97-	*	MCB 624	SV		MCB 615	SH	EC
	900 Elefant	B	93-	*	MCB 648	SV	EC	MCB 648	SH	EC
	900 Elefant I.E.	B	90-92		MCB 624	SV		MCB 615	SH	EC
	900 Gran Canyon	M3	99-	*	MCB 598	SV		MCB 615	SH	EC
	1000 Navigator	M5	00-05		MCB 598	SV		MCB 615	SH	EC
	1000 Raptor	M2	00-	*	MCB 683	SV		MCB 700	SH	RQ
	1000 Raptor X3	M2	03-04	*	MCB 721 SV	SRQ		MCB 700	SH	RQ
	1000 Raptor, X-tra Raptor	M2	00-05	*	MCB 683	SV		MCB 700	SH	RQ

Can-Am

DS	70		08-12					MCS 843		
DS	90		10-					MCS 843		
DS	90 X		10-13	*	MCB 519	SI	EC	MCB 519	SI	EC
DS	250		08-		MCB 760 SI			MCB 760 SI		
	400 Outlander, EFI, Max		07-	☞	MCB 724 SI			MCB 723 SI		
	400 Outlander, EFI, Max		07-	☞	MCB 723 SI					
DS	450		08-12	NO SHIMS!	MCB 859 SI			MCB 860 SI		
	500 Outlander, Max		07-	☞	MCB 724 SI			MCB 723 SI		
	500 Outlander, Max		07-	☞	MCB 723 SI					
	500 Outlander, Outlander Max		07-12	☞	MCB 724 SI			MCB 723 SI		
	500 Outlander, Outlander Max		07-12	☞	MCB 723 SI			MCB 723 SI		
	500 Outlander, Outlander Max		13-	☞	MCB 861 SI			MCB 861 SI		
	500 Outlander, Outlander Max		13-	☞	MCB 862 SI			MCB 862 SI		
	500 Renegade		07-	☞	MCB 724 SI			MCB 723 SI		
	500 Renegade		07-	☞	MCB 723 SI					
	500 Renegade		12-	☞	MCB 861 SI			MCB 861 SI		
	500 Renegade		12-	☞	MCB 862 SI			MCB 862 SI		
DS	650 X		07	☞	MCB 724 SI			MCB 723 SI		
DS	650 X		07	☞	MCB 723 SI					
	650 Outlander, Max		07-	☞	MCB 724 SI			MCB 723 SI		
	650 Outlander, Max		07-	☞	MCB 723 SI					
	650 Outlander, Outlander Max		13-	☞	MCB 861 SI			MCB 861 SI		
	650 Outlander, Outlander Max		13-	☞	MCB 862 SI			MCB 862 SI		
	800 Commander		11-	☞	MCB 615SI			MCB 582 SI		
	800 Commander		11-	☞	MCB 582SI					
	800 Outlander Max R		07-	☞	MCB 724 SI			MCB 723 SI		
	800 Outlander Max R		07-	☞	MCB 723 SI					
	800 Outlander R, R Max		12-	☞	MCB 861 SI			MCB 861 SI		
	800 Outlander R, R Max		12-	☞	MCB 862 SI			MCB 862 SI		
	800 Outlander, R, R EFI, R XT		07-	☞	MCB 724 SI			MCB 723 SI		
	800 Outlander, R, R EFI, R XT		07-	☞	MCB 723 SI					
	800 Renegade		08-11	☞	MCB 724 SI			MCB 723 SI		
	800 Renegade		08-11	☞	MCB 723 SI					
	800 Renegade		12-	☞	MCB 861 SI			MCB 861 SI		
	800 Renegade		12-	☞	MCB 862 SI			MCB 862 SI		
	1000 Commander		11-	☞	MCB 615SI			MCB 582 SI		
	1000 Commander		11-	☞	MCB 582SI					



* 2 Sätze erforderlich – 2 sets required
Parkbremse – Parkingbrake



ohne Verschleißanzeige – without wear indicator
linke Seite – left side
rechte Seite – right side



Option 1

Option 2

Option 3



Option 1

Option 2

Can-Am

1000 Commander MAX	14-	☑	MCB 615SI				MCB 724 SI		
1000 Commander MAX	14-	☑	MCB 582SI				MCB 723 SI		
1000 Maverick	13-	☑	MCB 615SI				MCB 724 SI		
1000 Maverick	13-	☑	MCB 582SI				MCB 723 SI		
1000 Outlander, Outlander Max	13-	☑	MCB 861 SI				MCB 861 SI		
1000 Outlander, Outlander Max	13-	☑	MCB 862 SI				MCB 862 SI		
1000 Renegade	12-	☑	MCB 861 SI				MCB 861 SI		
1000 Renegade	12-	☑	MCB 862 SI				MCB 862 SI		

CCM

CR40	400 Cafe Racer	07-08		MCB 540	SV	SRQ		MCB 672	SH	
SR40	400 Street Scrambler	07-09		MCB 734				MCB 672	SH	
	400 DS404	03-09		MCB 648 SI	RSI	EC		MCB 672 SI	RSI	EC
	450 MX	08-		MCB 648 SI	RSI	EC		MCB 739 SI	RSI	EC
	450 DS450	07-		MCB 648 SI	RSI	EC		MCB 672 SI	RSI	EC
	600 604 E Sport	98-		MCB 648 SI	RSI	EC		MCB 672 SI	RSI	EC
	600 604 E Sportmoto	98-06		MCB 648 SI	RSI	EC		MCB 672 SI	RSI	EC
	600 604 RS	01-		MCB 648 SI	RSI	EC		MCB 672 SI	RSI	EC
	600 R30	02-06		MCB 648 SI	RSI	EC		MCB 672 SI	RSI	EC
	650 DS644	02-06		MCB 648 SI	RSI	EC		MCB 672 SI	RSI	EC

CF Moto

CF	500 Everest	10-	*	MCB 761 SI						
CF	500 Terralander	13-	*	MCB 863 SI				MCB 756 SI		
CF	625 Terralander	11-	*	MCB 863 SI				MCB 756 SI		
	650 NK	14-	*	MCB 671	SV			MCB 672	SH	EC
	650 TK	14-	*	MCB 671	SV			MCB 672	SH	EC
CF	800 Terralander	12-	*	MCB 863 SI				MCB 756 SI		

CPI

	50 Aragon	07-		MCB 694	EC			MCS 962		
	50 Aragon GP	07-		MCB 694	EC			MCS 962		
	50 Baby	02-		MCB 519	EC	SR		MCS 962		
	50 Bravo	12-		MCB 519	EC	SR		MCS 962		
	50 Crab	03-						MCB 615 SI	EC	
	50 Formula R	07-		MCB 694	EC			MCS 962		
	50 Freaky	07-		MCB 694	EC			MCS 962		
	50 Hussar	JR	03-	MCB 694	EC			MCS 962		
	50 Hussar FL	JR	01-02	MCB 519	EC	SR		MCS 962		
	50 Mars	01-		MCB 519	EC	SR		MCS 962		
	50 Oliver	JR	03-	MCB 694	EC			MCS 962		
	50 Popcorn	JP	03-06	MCB 694	EC			MCS 951		
	50 Popcorn FL	JP	02	MCB 519	EC	SR		MCS 962		
	50 Supercross	03-		MCB 535	EC			MCB 535	EC	
	50 Supermotard	03-		MCB 535	EC			MCB 535	EC	
GTR	50	03-		MCB 700	EC			MCB 695	EC	
GTS	50	02-03		MCB 734	EC			MCB 695	EC	
XT	50 Quad	06-						MCB 615 SI	EC	
	100 Crab	03-						MCB 615 SI	EC	
	125 Aragon GP	07-08		MCB 694	EC			MCS 968		
	125 Aragon S-line	07-		MCB 694	EC			MCS 962		
	125 Sahel	02-		MCB 669	SI	RSI		MCB 575	SI	RSI
	125 X - Large	02-		MCB 700	SRM	EC		MCB 700	SRM	EC
GTS	125	02-03		MCB 734	EC			MCB 695	EC	
	125 Bravo	12-		MCB 519	EC	SR		MCS 962		
	200 X - Large	02-		MCB 700	SRM	EC		MCB 700	SRM	EC
GTS	200	02-03		MCB 734	EC			MCB 695	EC	
XS	250 ATV	06-07	*	MCB 760 SI				MCB 615 SI	EC	
XS	250 Power Quad	07-	*	MCB 519 SI	EC			MCB 805 SI		

Daelim

	50 Cordi	05-		MCB 510						
	50 Delfino	99-01		MCB 510				MCS 817		
	50 E-Five	03-		MCB 647						
	50 History	SE1	01-	MCB 510				MCB 510		
	50 Tapo	99-		MCB 510				MCS 813		



Option 1

Option 2

Option 3



Option 1

Option 2

Daelim

	50 Vivo		99-		MCB 510				MCS 817		
GZ	50 G Message	GZ50GF	98-		MCB 647						
SJ	50 S-Five	SE1	01-		MCB 647				MCB 510		
	100 Delfino		99-01		MCB 510				MCS 817		
	125 Besbi		08-		MCB 665	EC					
	125 Delfino		08-		MCB 689	EC					
	125 History	SL	01-		MCB 510				MCB 510		
	125 Massage II		00-		MCB 510				MCS 817		
	125 Otello	SG125F	99-		MCB 510				MCS 800		
	125 Otello DLX	SG	01-06		MCB 510				MCB 510		
	125 Roadwin	VJ125	04-07		MCB 599				MCB 604		
	125 Roadwin		08-		MCB 599				MCB 599		
	125 Rocket		99-		MCB 598	SRM			MCS 817		
NS	125 II	SG125F	97-		MCB 510				MCS 817		
S1	125 SL 125		07-	4 ☐	MCB 706	SRM	EC		MCB 510		
S2	125 Freewing		07-09	4 ☐	MCB 706	SRM	EC		MCB 510		
S2	125		05-06		MCB 598				MCB 510		
S3	125 SV 125		10-	4 ☐	MCB 706	SRM	EC		MCB 663	SRM	EC
U3	125 Otello FL		07-	4 ☐	MCB 706	SRM	EC		MCB 510		
VC	125 Advance	VS125	95-96		MCB 510				MCS 817		
VL	125 Daystar	VL125F	03-		MCB 598	SRM			MCS 817		
VS	125 Evolution	VS125	01-04		MCB 599				MCS 817		
VS	125 Evolution	VS125	95-00		MCB 510				MCS 817		
VT	125 Evolution	VS125F	00-		MCB 599				MCS 817		
VT	125 Magna	VT125F	97-		MCB 599						
ET	250 Quad		05-	*	MCB 519 SI	EC			MCB 604		
ST	250 Sector Quad		05-06	*	MCB 519 SI	EC			MCB 800		
	250 Roadwin		08-		MCB 599				MCB 604		
ET	300 Quad		07-	*	MCB 519 SI	EC			MCB 800		

Derbi

	25 Vamos		-93		MCS 921				MCS 921		
	25 Vamos		94-		MCB 535	EC	SR		MCS 921		
	50 Atlantis H2O, Wave	ATL	02		MCB 535	EC	SR		MCS 984		
	50 Atlantis, Wave	ATL	99-01		MCB 535	EC	SR		MCS 921		
	50 Atlantis 2T, 12"	AL	07		MCB 535	EC	SR		MCS 984		
	50 Atlantis 2T, AC, 12"	AL	07-11		MCB 765				MCS 984		
	50 Atlantis 4T	AL	07-09		MCB 765				MCS 994		
	50 Atlantis 4T, 13"	AL	04-06		MCB 535	EC	SR		MCS 994		
	50 Atlantis Bullet, Red Bullet	ATL	03-05		MCB 535	EC	SR		MCS 984		
	50 Atlantis City	ATL	03-06		MCB 535	EC	SR		MCS 984		
	50 Aventura	Aventura	96-		MCB 535	EC	SR		MCS 921		
	50 Boulevard	BR	09-	Hengtong	MCB 744	EC	SRM		MCS 994		
	50 Easy		98-		MCB 535	EC	SR		MCS 921		
	50 Fenix	Fenix H	94-		MCB 535	EC	SR		MCB 535	EC	SR
	50 Furax	Furax F	96-		MCB 535	EC	SR		MCB 535	EC	SR
	50 Hunter	Hunt	95-99		MCB 535	EC	SR				
	50 Manhattan		98-		MCB 535	EC	SR		MCS 921		
	50 Predator AC	Pred	98-01		MCB 535	EC	SR		MCS 921		
	50 Predator LC	Pred	98-03		MCB 535	EC	SR		MCB 535	EC	SR
	50 Record		98-		MCB 535	EC	SR		MCS 921		
	50 Senda DRD EVO SM		08-		MCB 700	EC			MCB 735	EC	
	50 Senda DRD Pro R, Pro SM		05-		MCB 700	EC			MCB 735	EC	
	50 Senda DRD Racing R	Send	11-		MCB 734	EC			MCB 535	EC	
	50 Senda DRD Racing R, SM	Send	04-10		MCB 734	EC			MCB 535	EC	
	50 Senda DRD Racing SM		11-		MCB 734	EC			MCB 519	EC	
	50 Senda L		99-02		MCB 564				MCB 564		
	50 Senda R	Senda H	94-02		MCB 535	EC	SR		MCB 535	EC	
	50 Senda X-Race R, SM		05-11		MCB 535	EC			MCB 535	EC	
	50 Senda X-Treme R		11-		MCB 519	EC			MCB 519	EC	
	50 Senda X-Treme R, SM		03-11		MCB 535	EC			MCB 535	EC	
	50 Senda X-Treme SM		11-		MCB 700	EC			MCB 519	EC	
	50 Vamos		-93		MCS 921				MCS 921		



* 2 Sätze erforderlich – 2 sets required
Parkbremse – Parkingbrake



ohne Verschleißanzeige – without wear indicator
linke Seite – left side
rechte Seite – right side



Option 1

Option 2

Option 3



Option 1

Option 2

Derbi

	50 Vamos L, FL	Vamos G	94-		MCB 535	EC	SR		MCS 921		
	50 Vamos R	Vamos G	95-	AJP	MCB 535	EC	SR		MCS 921		
	50 Vamos R	Vamos G	95-	Brembo	MCB 674	EC	SR		MCS 921		
	50 Variant Sport-R		12-		MCB 744	EC			MCS 994		
DFW	50		04-07		MCS 832				MCS 805		
FD	50 Yumbo		-84		MCB 596						
FD	50 Yumbo		84-		MCB 535	EC	SR				
FD	50 Yumbo Extra		-84		MCB 596						
FD	50 Yumbo Extra		87-		MCB 535	EC	SR				
FDT	50		-84		MCB 596						
FDT	50		87-		MCB 535	EC	SR				
FDT	50 Coppa		85		MCB 535	EC	SR				
GP1	50 Race	PR	05-07		MCB 700	EC	SRM		MCB 535	EC	SR
GP1	50	PR	01-03		MCB 535	EC	SR		MCB 535	EC	SR
GPI	50 Open	GR	06-11		MCB 700	EC	SRM		MCB 535	EC	SR
GPR	50 2T		09-		MCB 780	SV			MCB 535	EC	
GPR	50 Nude, Racing		04-10		MCB 700	EC	SRM		MCB 535	EC	
GPR	50 R/Replica	Pred	97-03		MCB 525	EC					
ST	50 Paddock	Hunt	97-99		MCB 535	EC	SR		MCS 921		
	50 Sonar		10-11		MCB 695	EC	SR		MCS 994		
	80 Senda		94-		MCB 535	EC			MCB 535	EC	
	100 Atlantis 2T		00-01		MCB 535	EC	SR		MCS 921		
	100 Atlantis 4T		04-06		MCB 535	EC	SR		MCS 994		
GPR	125 2T Racing		05-08		MCB 780	SV			MCB 535	EC	
GPR	125 Nude		05-08		MCB 780	SV			MCB 535	EC	
GPR	125 4T	RG	09-		MCB 780	SV			MCB 765		
	125 Atmosphere		99-		MCB 629				MCS 921		
	125 Boulevard	BL	03-07		MCB 735	EC			MCS 994		
	125 Boulevard 4 T	M57	08-	Hengtong	MCB 744	SRM	EC		MCS 994		
	125 Cross City		07-08		MCB 734	EC			MCB 735	EC	
	125 Cross City		09-		MCB 818				MCB 735	EC	
	125 Mulhacen	-7N001790	07		MCB 734	EC			MCB 765		
	125 Mulhacen	7N001791-	07-10		MCB 818				MCB 765		
	125 Mulhacen		08-11	Radialc.	MCB 700	EC			MCB 765		
	125 Predator	Pred	99-		MCB 535	EC	SR		MCS 921		
GP1	125 Racing		07-09		MCB 700	SRM	EC		MCB 735	EC	
	125 Rambla	RA	08-		MCB 673	EC			MCB 710	EC	
GP1	125 Scooter		06		MCB 700	SRM	EC		MCB 700	SRM	EC
GP1	125 Scooter		06-07		MCB 700	SRM	EC		MCB 700	SRM	EC
	125 Senda Baja R, SM		06-		MCB 734	EC			MCB 735	EC	
	125 Senda Cross City	SC2D1B	07-		MCB 818				MCB 735	EC	
	125 Senda DRD R, SM		10-		MCB 700				MCB 765		
	125 Senda R, SM		04-07		MCB 734	EC			MCB 735	EC	
	125 Sonar		10-		MCB 695	EC			MCS 994		
	125 Terra		07		MCB 535	EC			MCB 75		
	125 Terra, Terra Adventure		08-		MCB 818				MCB 765		
	125 Variant Sport-R		12-		MCB 744	EC			MCS 994		
	150 Boulevard		03-07	Hengtong	MCB 735	EC			MCS 994		
	150 Sonar		09-10		MCB 695	EC			MCS 994		
	180 Predator		99-		MCB 629				MCS 921		
	200 Boulevard		05		MCB 735	EC			MCS 994		
DXR	200		04-05		MCS 962				MCB 523 SI		
DXR	200		04-07		* MCB 519 SI	EC			MCB 523 SI		
DXR	250		04-05		MCS 962				MCB 523 SI		
DXR	250		04-07		* MCB 519 SI	EC			MCB 523 SI		
	250 RC		85		MCB 75						
	250 T		-82		MCB 596						
GP1	250 Racing		07-		MCB 700	SRM	EC		MCB 735	EC	
	250 Rambla i	RA	08-09		MCB 673	EC			MCB 710	SRM	EC
	300 Rambla i	RA	10-		MCB 673	EC			MCB 710	SRM	EC
	659 Mulhacen		05	4☐ *	MCB 742 SV	SRQ	CRQ	SCR	MCB 700	RQ	
	659 Mulhacen		06-08	4☐ *	MCB 721 SV	SRQ	CRQ	SCR	MCB 700	RQ	



Option 1

Option 2

Option 3



Option 1

Option 2

Ducati

	350 Desmo			4 ☐ *	MCB 19	SV						
	350 F3	86		4 ☐ *	MCB 75				MCB 75	RQ		
	350 Indiana	86			MCB 563				MCB 75	RQ		
	350 Paso	86		*	MCB 75				MCB 75	RQ		
	350 S	77-78			MCB 75							
	350 SS Supersport	93			MCB 540 SV	SRQ	CRQ		MCB 75	RQ		
GTL	350	77			MCB 75							
GTV	350	77			MCB 75				MCB 75	RQ		
SL	350 Pantha				MCB 19				MCB 19	RQ		
XL	350 Pantha	82-83			MCB 75				MCB 75	RQ		
	400 F3	87-			MCB 75				MCB 75	RQ		
	400 Monster (Japan)	M3	01-		MCB 683	SV	SRQ	CRQ	MCB 75			
	400 SS	S	93-97		MCB 540 SV	SRQ	CRQ		MCB 75	RQ		
	500 Pantah		85		MCB 75				MCB 75	RQ		
	500 S		77-78		MCB 75							
GTL	500		77-79		MCB 75							
GTV	500		77-78		MCB 75				MCB 75	RQ		
GTV	500		79-		MCB 19				MCB 19	RQ		
	600 Monster	M3	00-01		MCB 683	SV	SRQ	CRQ	MCB 75	RQ		
	600 Monster	M	94-99		MCB 540				MCB 75	RQ		
	600 SS	S	94-98		MCB 540 SV	SRQ	CRQ		MCB 75	RQ		
	600 Pantha		81-		MCB 19	SV	RQ		MCB 19	RQ		
	620 Monster Dark i.e.	M4	02-		MCB 683 SV	SRQ	CRQ		MCB 75	RQ		
	620 Monster i.e., S i.e	M4	02-04	*	MCB 683 SV	SRQ	CRQ		MCB 75	RQ		
	620 Sport	V5	02-07	*	MCB 683 SV	SRQ	CRQ		MCB 700	SH	RQ	
	620 Monster Dark	M4	05-06	*	MCB 671	SV			MCB 75	RQ		
	620 Multistrada	A1	05-06	*	MCB 648	SV			MCB 75	RQ		
	620 Multistrada Dark		03-04	*	MCB 648	SV			MCB 75	RQ		
	620 Multistrada Dark		05-06	*	MCB 683	SV			MCB 700	SH	RQ	
	650 Indiana		86		MCB 563				MCB 75			
	650 Pantah		84-88		MCB 75				MCB 75			
	695 Monster	M4	06-08	*	MCB 648	SV			MCB 75	RQ		
	696 Monster	M5	08-	*	MCB 683	SV	SRQ	CRQ	MCB 700	SH		
	696 Monster ABS	M5	08-	*	MCB 683	SV	SRQ	CRQ	MCB 700	SH		
	748	748S	95-99	*	MCB 540 SV	SRQ	CRQ		MCB 75	RQ		
	748	H3	00-03	*	MCB 683 SV	SRQ	CRQ		MCB 75	RQ		
	748 R	748S	99	*	MCB 683 SV	SRQ	CRQ	SCR	MCB 75	RQ		
	748 R	H3	00-02	4 ☐ *	MCB 721 SV	SRQ	CRQ	SCR	MCB 700	SH	RQ	
	748 S	748S	97-99	4 ☐ *	MCB 683 SV	SRQ	CRQ		MCB 75	RQ		
	748 S	H3	00-02	*	MCB 683 SV	SRQ	CRQ		MCB 75	RQ		
	748 SP	748S	95-97		MCB 540 SV	SRQ	CRQ		MCB 75	RQ		
	748 SPS	748S	98-99	*	MCB 683 SV	SRQ	CRQ	SCR	MCB 75	RQ		
	749	H5	03-07	4 ☐ *	MCB 721 SV	SRQ	CRQ	SCR	MCB 700	SH	RQ	
	749 S	H5	03-07	4 ☐ *	MCB 721 SV	SRQ	CRQ	SCR	MCB 700	SH	RQ	
	749 R	H5	04-07	4 ☐ *	MCB 721 SV	SRQ	CRQ	SCR	MCB 700	SH	RQ	
	750 F1		86	4 ☐ *	MCB 19	RQ			MCB 19			
	750 Monster	M1	96-99	4 ☐ *	MCB 540 SV	SRQ	CRQ		MCB 75	RQ		
	750 Monster	M1	00-01	*	MCB 683 SV	SRQ	CRQ		MCB 75	RQ		
	750 Monster i.e.	M4	02	*	MCB 683 SV	SRQ	CRQ		MCB 75	RQ		
	750 Paso		86-	*	MCB 75				MCB 75	RQ		
	750 Sport	ZDM750S	00-	*	MCB 683 SV	SRQ	CRQ		MCB 700	SH	RQ	
	750 SS i.e.	S	99-	*	MCB 683 SV	SRQ	CRQ		MCB 75	RQ		
	750 SS Supersport	S	91-98	*	MCB 540 SV	SRQ	CRQ		MCB 75	RQ		
	750 Supersport	V2	00-	*	MCB 683 SV	SRQ	CRQ		MCB 75	RQ		
	796 Hypermotard	B1	10-12	*	MCB 683 SV	SRQ	CRQ		MCB 700	SH		
	796 Monster	M5	10-	*	MCB 683 SV	SRQ	CRQ		MCB 700	SH	RQ	
	796 Monster ABS	M5	10-	*	MCB 683 SV	SRQ	CRQ		MCB 700	SH	RQ	
	800 Scrambler		15-	*	MCB 856 SV				MCB 672	SH		
	800 Monster Dark i.e., S i.e.	M4	03-04	*	MCB 683 SV	SRQ	CRQ		MCB 75	RQ		
	800 Monster i.e., S i.e.	M4	03-04	*	MCB 683 SV	SRQ	CRQ		MCB 75	RQ		
	800 Sport, Supersport	V5	03-05	*	MCB 683 SV	SRQ	CRQ		MCB 700	SH	RQ	
S2R	800 Monster	M4	05-07	*	MCB 648	SV			MCB 75	RQ		
	821 Hypermotard	B1	13-	*	MCB 856 SV				MCB 700	SH	RQ	



* 2 Sätze erforderlich – 2 sets required
Parkbremse – Parkingbrake



ohne Verschleißanzeige – without wear indicator
linke Seite – left side
rechte Seite – right side



Option 1

Option 2

Option 3



Option 1

Option 2

Ducati

	821 Hypermotard ABS	B1	13-		*	MCB 856 SV				MCB 700	SH	RQ
	821 Hyperstrada	B1	13-		*	MCB 856 SV				MCB 700	SH	RQ
	821 Hyperstrada ABS	B1	13-		*	MCB 856 SV				MCB 700	SH	RQ
	821 Monster ABS		15-		*	MCB 856 SV				MCB 700	SH	RQ
	848 Evo, Evo Corse	H6	11-		*	MCB 792 SV	SRQ	CRQ	SCR	MCB 700	SH	RQ
	848 Streetfighter	F1	12-		*	MCB 683	SV	SRQ		MCB 700	SH	RQ
	848 Streetfighter S	F1	12-		*	MCB 792 SV	SRQ			MCB 700	SH	RQ
	848	H6	08-10		*	MCB 683 SV	SRQ	CRQ	SCR	MCB 700	SH	RQ
	851 S		88-90		*	MCB 540 SV	SRQ	CRQ		MCB 75	RQ	
	851 Strada		91-92		*	MCB 540 SV	SRQ	CRQ		MCB 75	RQ	
	888 SP4	S	92-		*	MCB 540 SV	SRQ	CRQ		MCB 75	RQ	
	888 SP5	S	93-		*	MCB 540 SV	SRQ	CRQ		MCB 75	RQ	
	888 Strada	S	93-		*	MCB 540 SV	SRQ	CRQ		MCB 75	RQ	
	888 SP, SP2, SP3		89-91		*	MCB 540 SV	SRQ	CRQ		MCB 75	RQ	
	899 Panigale	H8	13-		*	MCB 856 SV				MCB 700 SH	RQ	
	900 Monster	900M	93-99		*	MCB 540 SV	SRQ	CRQ		MCB 75	RQ	
	900 Monster i.e., S i.e.	M2	00-02		*	MCB 683	SV	SRQ	CRQ	MCB 75	RQ	
	900 S2 Desmo	S	85		*	MCB 19	RQ			MCB 19	RQ	
	900 SS FE	S	98-		*	MCB 683 SV	SRQ	CRQ		MCB 700	SH	RQ
	900 SS i.e. Carenata	S	99-		*	MCB 683 SV	SRQ	CRQ		MCB 700	SH	RQ
	900 SS i.e. Nuda	S	99-		*	MCB 683 SV	SRQ	CRQ		MCB 75	RQ	
	900 Superlight		91-		*	MCB 540 SV	SRQ	CRQ		MCB 75	RQ	
	900 Supersport	S	90-97		*	MCB 540 SV	SRQ	CRQ		MCB 75	RQ	
	900 Supersport	V1	98-		*	MCB 683 SV	SRQ	CRQ		MCB 700	SH	RQ
MH	900 Mike Hailwood R.	MH	85		*	MCB 19	RQ			MCB 19	RQ	
MH	900 Mike Hailwood R.	V3	00-		*	MCB 683 SV	SRQ	CRQ		MCB 75	RQ	
	900 GTS		75-76		*	MCB 19	SV	RQ		MCB 19	RQ	
	900 SS Darmah		76-78		*	MCB 19	SV	RQ		MCB 19	RQ	
	906 Paso		89		*	MCB 19	RQ			MCB 19	RQ	
	907 i.E.		91-		*	MCB 540 SV	SRQ	CRQ		MCB 75	RQ	
	916	916	95-98		*	MCB 683 SV	SRQ	CRQ	SCR	MCB 75	RQ	
	916 Strada Biposto	1SB	95-98		*	MCB 540 SV	SRQ	CRQ		MCB 75	RQ	
	916 SP	916	94-96		*	MCB 683 SV	SRQ	CRQ	SCR	MCB 75	RQ	
	916 Strada	916	94-98		*	MCB 540 SV	SRQ	CRQ		MCB 75	RQ	
S4	916 Monster	M4	00-04		*	MCB 683	SV	SRQ	CRQ	MCB 75	RQ	
ST4	916	S2	99-03		*	MCB 683	SV	SRQ	CRQ	MCB 700	SH	RQ
ST2	944	S1	97-03		*	MCB 683	SV	SRQ	CRQ	MCB 700	SH	RQ
	990 Desmosedici RR	D1	08-09		*	MCB 792 SV	SRQ	CRQ	SCR	MCB 700	SH	RQ
ST3	992	S3	04-		*	MCB 683	SV	SRQ	CRQ	MCB 700	SH	RQ
S4R	996 Monster	M4	03-06		*	MCB 683	SV	SRQ	CRQ	MCB 700	SH	RQ
	996 R	H2	01		4☐ *	MCB 721 SV	SRQ	CRQ	SCR	MCB 700	SH	RQ
	996 S	H1	01-		4☐ *	MCB 683 SV	SRQ	CRQ		MCB 75	RQ	
ST4S	996	S2	01-03		4☐ *	MCB 683 SV	SRQ	CRQ		MCB 75	RQ	
ST4S	996	S3	04-05		4☐ *	MCB 683 SV	SRQ	CRQ		MCB 75	RQ	
ST4S	996 ABS	S2	03		4☐ *	MCB 683 SV	SRQ	CRQ		MCB 75	RQ	
ST4S	996 ABS	S3	04-05		*	MCB 683 SV	SRQ	CRQ		MCB 75	RQ	
	998	H2	02-03		4☐ *	MCB 721 SV	SRQ	CRQ	SCR	MCB 700	SH	RQ
	998 R	H2	02-03		4☐ *	MCB 721 SV	SRQ	CRQ	SCR	MCB 700	SH	RQ
	998 S	H2	02		4☐ *	MCB 683 SV	SRQ	CRQ	SCR	MCB 75	RQ	
	999	H4	03-06		4☐ *	MCB 721 SV	SRQ	CRQ	SCR	MCB 700	SH	RQ
	999 R	H4	03-06		4☐ *	MCB 721 SV	SRQ	CRQ	SCR	MCB 700	SH	RQ
	999 S	H4	03-06		4☐ *	MCB 721 SV	SRQ	CRQ	SCR	MCB 700	SH	RQ
	1000 Mike Hailwood R.	MH	85		4☐ *	MCB 19	RQ			MCB 19	RQ	
	1000 Mille Replica		84		4☐ *	MCB 19	RQ			MCB 19	RQ	
	1000 Multistrada DS	A1	03-06		4☐ *	MCB 683 SV	SRQ	CRQ		MCB 700	RQ	
	1000 S2 Desmo		85		4☐ *	MCB 19	RQ			MCB 19	RQ	
	1000 SS	V5	03-07		*	MCB 683 SV	SRQ	CRQ		MCB 700	SH	RQ
	1000 Monster i.e., S i.e.	M4	03-06		*	MCB 683 SV	SRQ	CRQ		MCB 75	RQ	
S2R	1000 Monster	M4	06-07		*	MCB 683 SV	SRQ	CRQ		MCB 75	RQ	
S4R	1000 Monster	M4	07-08		*	MCB 683 SV	SRQ	CRQ		MCB 75	RQ	
S4RS	1000 Monster	M4	06-08		4☐ *	MCB 721 SV	SRQ	CRQ	SCR	MCB 700	SH	RQ
	1000 Sport	C1	06-08		*	MCB 671 SV				MCB 672	SH	
	1000 S Sport	C1	07-09		*	MCB 671 SV				MCB 672	SH	
GT	1000 Sport Classic	C1	06-09		*	MCB 671 SV				MCB 672	SH	
	1098	H7	07-08		*	MCB 792 SV	SRQ	CRQ	SCR	MCB 700	SH	RQ



Option 1

Option 2

Option 3



Option 1

Option 2

Ducati

1098 R	H7	08-09		*	MCB 792 SV	SRQ	CRQ	SCR	MCB 700	SH	RQ
1098 S	H7	07-08		*	MCB 792 SV	SRQ	CRQ	SCR	MCB 700	SH	RQ
1100 Hypermotard	B1	07-09		*	MCB 683 SV	SRQ	CRQ		MCB 700	SH	RQ
1100 Hypermotard S/SP	B1	07-12		*	MCB 792 SV	SRQ	CRQ	SCR	MCB 700	SH	RQ
1100 Monster Evo	M5	11-	Radialc.	*	MCB 683 SV	SRQ	CRQ		MCB 700	SH	RQ
1100 Monster Evo ABS	M5	11-	Radialc.	*	MCB 683 SV	SRQ	CRQ		MCB 700	SH	RQ
1100 Monster	M5	09-10		*	MCB 683 SV	SRQ	CRQ		MCB 700	SH	RQ
1100 Monster ABS	M5	09-10		*	MCB 683 SV	SRQ	CRQ		MCB 700	SH	RQ
1100 Monster S	M5	09-10		*	MCB 683 SV	SRQ	CRQ		MCB 700	SH	RQ
1100 Monster S ABS	M5	10		*	MCB 683 SV	SRQ	CRQ		MCB 700	SH	RQ
1100 Multistrada	A1	06-09		*	MCB 683 SV	SRQ	CRQ		MCB 700	SH	RQ
1100 Streetfighter	F1	09-11		*	MCB 792 SV	SRQ	CRQ	SCR	MCB 700	SH	RQ
1100 S Streetfighter	F1	09-		*	MCB 792 SV	SRQ	CRQ	SCR	MCB 700	SH	RQ
1100 S Streetfighter ABS	F1	11-		*	MCB 792 SV	SRQ	CRQ	SCR	MCB 700	SH	RQ
1198 R	H7	09-		*	MCB 792 SV	SRQ	CRQ	SCR	MCB 700	SH	RQ
1198 S	H7	09-		*	MCB 792 SV	SRQ	CRQ	SCR	MCB 700	SH	RQ
1198 SP	H7	09-		*	MCB 792 SV	SRQ	CRQ	SCR	MCB 700	SH	RQ
1199 Panigale, S, R	H8	12-14		*	MCB 792 SV	SRQ	CRQ	SCR	MCB 700	SH	RQ
1199 Panigale, S, R, ABS	H8	12-14		*	MCB 792 SV	SRQ	CRQ	SCR	MCB 700	SH	RQ
1199 Superleggera	H8	14-		*	MCB 792 SV	SRQ	CRQ	SCR	MCB 700	SH	RQ
1200 Diavel	G1	11-		*	MCB 792 SV	SRQ	CRQ	SCR	MCB 671	SH	
1200 Diavel ABS	G1	11-		*	MCB 792 SV	SRQ	CRQ	SCR	MCB 671	SH	
1200 Monster	M6	14-		*	MCB 856 SV	SRQ			MCB 700	SH	RQ
1200 Monster S	M6	14-		*	MCB 792 SV	SRQ	CRQ		MCB 700	SH	RQ
1200 Multistrada ABS	A2	10-12		*	MCB 683 SV	SRQ	CRQ		MCB 700	SH	RQ
1200 Multistrada S ABS	A2	10-12		*	MCB 683 SV	SRQ	CRQ		MCB 700	SH	RQ
1200 Multistrada ABS	A3	13-14		*	MCB 683 SV	SRQ	CRQ		MCB 700	SH	RQ
1200 Multistrada S ABS	A3	13-14		*	MCB 683 SV	SRQ	CRQ		MCB 700	SH	RQ
1200 Multistrada ABS		15-		*	MCB 856 SV	SRQ	CRQ		MCB 648	SH	
1200 Multistrada S ABS		15-		*	MCB 792 SV	SRQ	CRQ		MCB 648	SH	
1299 Panigale, S, R ABS		15-		*	MCB 792 SV	SRQ	CRQ	SCR	MCB 700	SH	RQ

E-Ton

JXL	40 Viper	03-04							MCS 819		
DXL	90 Ranger	03-04							MCS 819		
DXL	90 Sierra	99-03			MCS 838				MCS 819		
EXL	150 Eukon	05-07			MCS 838				MCB 615	EC	
EXL	150 Viper ST	05-		*	MCB 519	SI	EC		MCS 819		
EXL	150 Yukon ST	05-		*	MCB 519	SI	EC		MCS 819		
RXL	150 Viper R	05-		*	MCS 800				MCB 615 SI	EC	
YXL	150 Yukon	00-03		*	MCS 800				MCB 615 SI	EC	
VXL	250 Vector	06-		*	MCB 800				MCB 517		
VXL	300 Vector	06-		*	MCB 800				MCB 517		
VTX	300 Vortex	06-		*	MCB 519	SI	EC		MCB 517		

EBR

1190 RX		14-		*	MCB 810 SV				MCB 811 SH		
1190 SX		14-		*	MCB 810 SV				MCB 811 SH		

Elstars

125 Blade		10-			MCB 844				MCB 844		
-----------	--	-----	--	--	---------	--	--	--	---------	--	--

Endres

50 EMR AP, DJ		96-			MCS 800				MCS 800		
50 EMR SK, TD		95-			MCB 665		EC		MCS 800		

Ering (Baotian)

50 Big Panther					MCB 590	EC					
50 Dynamic					MCB 590	EC					
50 Smart Rider					MCB 590	EC					
50 Warrior					MCB 590	EC					

Ering (HerChee)

50 s. Adly, s. Buffalo					MCB 590	EC					
------------------------	--	--	--	--	---------	----	--	--	--	--	--



* 2 Sätze erforderlich – 2 sets required
Parkbremse – Parkingbrake



ohne Verschleißanzeige – without wear indicator



linke Seite – left side



rechte Seite – right side



Option 1

Option 2

Option 3



Option 1

Option 2

Factory

	50 Helix	04-						MCB 519	SI	EC
	50 Rex	04-						MCB 519	SI	EC
R14	50 Phantom Aire	03-		MCB 535	EC					
RP	50 Desert	04-		MCB 664	EC			MCB 535	EC	
SM	50 Chrono	04-		MCB 664	EC			MCB 535	EC	
SP	50 Chrono	04-		MCB 664	EC			MCB 535	EC	
YR	50 Desert	04-		MCB 664	EC			MCB 535	EC	
	100 Helix	04-						MCB 519	SI	EC
	100 Rex	04-						MCB 519	SI	EC
YR	125	06-		MCB 525	EC			MCB 535	EC	

Fantic

	50 Big Wheel	93-		MCB 590	EC			MCB 657		
	50 Grinta	95-		MCB 590	EC			MCB 657		
	50 Leader	95-		MCB 590	EC			MCB 657		
	50 Pony	93-		MCB 590	EC			MCS 962		
	50 Queenie	93-		MCB 590	EC			MCS 962		
	50 RC Caballero	95-		MCB 664				MCB 657		
	50 Regolarna Casa	08-		MCB 734	EC			MCB 519	SI	EC
	50 Supersei Motard	08-		MCB 734	EC			MCB 519	SI	EC
	50 Regolarna Competition	08-		MCB 669	SI	RSI	EC	MCB 575 SI	RSI	EC
	80 Regolarna Competition	08-		MCB 669	SI	RSI	EC	MCB 575 SI	RSI	EC
	80 RC Caballero	95-		MCB 664				MCB 552		
	80 Trial	89		MCB 535	RQ	EC		MCB 535	RQ	EC
	85 Regolarna Competition	08-		MCB 669	SI	RSI	EC	MCB 575 SI	RSI	EC
	125 Hit	94-		MCB 590	EC			MCS 962		
	125 Raider	83-		MCB 552						
	125 Regolarna Casa	08-		MCB 734	EC			MCB 519	SI	EC
	125 Regolarna Competition	08-		MCB 669	SI	RSI	EC	MCB 575 SI	RSI	EC
	125 Supersei Motard	08-		MCB 734	EC			MCB 519	SI	EC
	125 Trial	86		MCB 564						
	125 Trial	87		MCB 564				MCB 564		
	125 Trial	89		MCB 535	RQ	EC		MCB 535	RQ	EC
	201 Trial	86-		MCB 564						
	205 Trial	89-		MCB 535	RQ	EC		MCB 535	RQ	EC
	240 Trial	86-		MCB 564						
	241 Trial	86-		MCB 564						
	243 Trial	86-		MCB 564						
	247 Trial	90-		MCB 535	RQ	EC		MCB 535	RQ	EC
	249 Trial	90-		MCB 535	RQ	EC		MCB 535	RQ	EC
	250 K-R00	91-		MCB 535	RQ	EC		MCB 535	RQ	EC
	250 Raider	85-		MCB 557						
	301 Trial	85-		MCB 564						
	303 Trial	87-		MCB 535	RQ	EC		MCB 535	RQ	EC
	305 Trial	89-		MCB 535	RQ	EC		MCB 535	RQ	EC
	307 Trial	90-		MCB 535	RQ	EC		MCB 535	RQ	EC
	309 Trial	90-		MCB 535	RQ	EC		MCB 535	RQ	EC

FlexTech (Baotian)

BT	50 QT			MCB 590	EC					
----	-------	--	--	---------	----	--	--	--	--	--

FlexTech (Benzhou)

	25 Firenze	09-		MCB 590	EC					
	25 Fun			MCB 590	EC					
	25 Piacenza	10-		MCB 590	EC					
	25 Top Speed	09-		MCB 590	EC					
	50 Firenze	09-		MCB 590	EC					
	50 Fun			MCB 590	EC					
	50 Piacenza	10-		MCB 590	EC					
	50 Top Speed	09-		MCB 590	EC					
YY	50 QT			MCB 590	EC					
	50 Napoli			MCB 590	EC					
	50 Speedy, TVZ			MCB 519	EC	SR				
	Eco-flash 2000		Electric	MCB 822						



Option 1

Option 2

Option 3



Option 1

Option 2

FlexTech (Benzhou)

125 Firenze	09-	MCB 590	EC						
125 Fun		MCB 590	EC						
125 Piacenza	10-	MCB 590	EC						
125 Top Speed	09-	MCB 590	EC						

FlexTech (Jinlun)

50 Hurrican X1, X2		MCB 822							
--------------------	--	---------	--	--	--	--	--	--	--

Garelli

50 Capri LX	QT-7	06-	MCB 590	EC					
50 Ciclone		07-	MCB 590	EC					
50 Flo		00-	MCB 674	EC					
50 Grinta		95-	MCB 590	EC			MCS 962		
50 Pony		93-94	MCS 962				MCS 962		
50 Pony SR		95-	MCB 590	EC			MCS 962		
50 Queenie		95-	MCB 590	EC			MCS 962		
50 Sahel		91-	MCB 578				MCB 535	EC	
PMX 50 Rally		00-	MCB 590						
PMX 50 Sport		00-	MCB 684						
50 Flexi		09-	MCB 694	EC					
50 GSP 2T		09-	MCB 694	EC			MCB 535	EC	
50 Tiesse Four 4T		08-	MCB 694	EC			MCS 962		
50 Vip		08-	MCB 590	EC					
50 XO 2T,4T	QT-31	10-	MCB 694	EC			MCB 694	EC	
50 XO Electric		12-	MCB 822				MCB 539	EC	
80 Sahel		91-	MCB 578				MCB 535	EC	
125 T-Rex		00-	MCB 684	EC					
125 Flexi		09-	MCB 694	EC					
125 Flexi		12-	MCB 822						
125 Freeland		02-	MCB 684	EC					
125 Panther		02-	MCB 647				MCB 674	EC	
125 XO	TM125T	09-	MCB 822				MCB 539	EC	
150 Panther		02-	MCB 647				MCB 674	EC	
150 XO	TM150T	09-	MCB 822				MCB 539	EC	
200 XO	TM200T	10-	MCB 689	EC			MCB 539	EC	
250 Panther		02-	MCB 647				MCB 674	EC	
323 Trial		86-	MCB 535	RQ	EC				

Gas Gas

50 Wild HP		04-	* MCB 648 SI	RSI	EC		MCB 648 SI	RSI	EC
EC 50 Boy, Rookie		01-	MCB 770				MCB 770		
TXT 50 Boy, Rookie		01-	MCB 770				MCB 770		
MC 65		05-	MCB 770				MCB 770		
TXT 80 Rookie		02-03	MCB 770				MCB 770		
TXT 80 Rookie		04-06	MCB 776				MCB 767		
125 4-Takt		99-	MCB 535	EC			MCB 535	EC	
125 Pampera		04-	MCB 734	EC			MCB 770		
125 Pampera		97-03	MCB 535	EC			MCB 535	EC	
EC 125		10-	MCB 669	SI	RSI	EC	MCB 739 SI	RSI	EC
EC 125		99-09	MCB 669	SI	RSI	EC	MCB 575 SI	RSI	EC
MC 125		03-09	MCB 669 SI	RSI	EC		MCB 575 SI	RSI	EC
MC 125		94-02	MCB 648 SI	RSI	EC		MCB 672 SI	RSI	EC
TT 125		94	MCB 648 SI	RSI	EC		MCB 523 SI		
TT 125		95-	MCB 648 SI	RSI	EC		MCB 672 SI	RSI	EC
TX 125 Randonne		12-	MCB 766				MCB 767		
TXT 125		04-	MCB 766				MCB 767		
EC 200		10-	MCB 669	SI	RSI	EC	MCB 739 SI	RSI	EC
EC 200		99-09	MCB 669	SI	RSI	EC	MCB 575 SI	RSI	EC
MC 200		03-09	MCB 669 SI	RSI	EC		MCB 575 SI	RSI	EC
MC 200		94-02	MCB 648 SI	RSI	EC		MCB 672 SI	RSI	EC
TXT 200		04-	MCB 766				MCB 767		
240 Wild HP		04-	* MCB 648 SI	RSI	EC		MCB 648 SI	RSI	EC
250 Pampera		97-03	MCB 535	EC			MCB 535	EC	



* 2 Sätze erforderlich – 2 sets required
Parkbremse – Parkingbrake



ohne Verschleißanzeige – without wear indicator
linke Seite – left side
rechte Seite – right side



Option 1

Option 2

Option 3



Option 1

Option 2

Gas Gas

	250 Pampera	04-		MCB 734	EC			MCB 770		
EC	250	00-09		MCB 669	SI	RSI	EC	MCB 575 SI	RSI	EC
EC	250	10-		MCB 669	SI	RSI	EC	MCB 739 SI	RSI	EC
MC	250	03-09		MCB 669 SI	RSI	EC		MCB 575 SI	RSI	EC
MC	250	95-02		MCB 648 SI	RSI	EC		MCB 672 SI	RSI	EC
TT	250 TT	94		MCB 648 SI	RSI	EC		MCB 523 SI		
TT	250 TT	95-		MCB 648 SI	RSI	EC		MCB 672 SI	RSI	EC
TXT	250	04-		MCB 766				MCB 767		
	280 Pampera	02-		MCB 734	EC			MCB 770		
TXT	280	04-		MCB 766				MCB 767		
	300 Wild HP	03-		* MCB 648 SI	RSI	EC		MCB 648 SI	RSI	EC
EC	300	99-09		MCB 669	SI	RSI	EC	MCB 575 SI	RSI	EC
EC	300	10-		MCB 669	SI	RSI	EC	MCB 739 SI	RSI	EC
TXT	300	04-		MCB 766				MCB 767		
	370 Pampera	97-		MCB 535	EC			MCB 535	EC	
SM	400 fse	02-		MCB 540	SV	SRQ	CRQ	MCB 575 SI	RSI	EC
	400 Pampera	06-		MCB 669 SI	RSI	EC		MCB 575 SI	RSI	EC
	450 Wild HP	03-		* MCB 648 SI	RSI	EC		MCB 648 SI	RSI	EC
EC	450 fse, fsr	03-09		MCB 669 SI	RSI	EC		MCB 575 SI	RSI	EC
EC	450	10-		MCB 669 SI	RSI	EC		MCB 739 SI	RSI	EC
SM	450 fse	03-06		MCB 540	SV	SRQ	CRQ	MCB 575 SI	RSI	EC
SM	450 FSR	07-		MCB 540	SV	SRQ	CRQ	MCB 575 SI	RSI	EC
EC	515 FSR	08-09		MCB 669 SI	RSI	EC		MCB 575 SI	RSI	EC
EC	515 FSR	10-		MCB 669 SI	RSI	EC		MCB 739 SI	RSI	EC
	alle Trial Modelle	92-		MCB 535	RQ	EC		MCB 535	RQ	EC

Generic

	50 Mini Trigger SM, X	08-		MCB 844				MCB 844		
	50 Trigger SM, X	06-		MCB 734	EC			MCB 552		
	50 Cracker B05	09-		MCB 694	EC			MCS 962		
	50 Epico	10-		MCB 694	EC			MCS 962		
	50 Ideo	05-		MCB 694	EC			MCS 962		
	50 Onyx	10-		MCB 674	EC			MCS 962		
	50 Roc, Stroke	08-		MCB 694	EC			MCS 962		
	50 Toxic	07-		MCB 734	EC			MCB 674	EC	
	50 XOR	05-		MCB 694	EC			MCS 962		
	125 Soho	06-		MCB 694	EC			MCS 968		
	125 Stroke	08-		MCB 694	EC			MCS 968		
	125 Trigger SM, X	08-		MCB 734	EC			MCB 552		
	125 XOR	05-		MCB 694	EC			MCS 968		
	125 Zion	08-		MCB 689	EC			MCS 968		
GSR	600	13		* MCB 721 SV	SRQ			MCB 700 SH		

Gilera

	50 DNA C27	01-05	Grimeca	MCB 664	EC	SRM		MCB 596		
	50 DNA C27	01-05	Hengtong	MCB 744	EC	SRM		MCB 596		
	50 Eaglet 503	96-		MCB 578				MCB 657		
	50 Easy Moving	95-		MCB 674	EC	SR		MCS 800		
	50 GSM	00-		MCB 535	EC	SR		MCB 535	EC	SR
	50 H@K C33	00-		MCB 535	EC	SR		MCB 535	EC	SR
	50 Ice C30	01-		MCB 696	EC	SR		MCS 989		
	50 Purejet C14	99-		MCB 696	EC	SR		MCB 695	EC	SR
	50 Runner	96		MCB 688	EC			MCS 989		
	50 Runner C14	97-		MCB 696	EC	SR		MCS 984		
	50 Runner SP C14	98-05		MCB 696	EC	SR		MCB 827	EC	
	50 Runner SP C46	06-		MCB 744	EC	SRM		MCB 827	EC	
	50 Stalker C13	97-03		MCB 674	EC	SR		MCB 827	EC	
	50 Stalker C40	04-06		MCB 674	EC	SR		MCB 522		
	50 Storm TEC	94-95		MCB 674	EC	SR		MCS 800		
	50 Storm C29	07-11		MCB 674	EC	SR		MCS 989		
	50 Surfer	00-		MCB 535	EC	SR		MCS 984		
	50 Typhoon	93-95		MCB 674	EC	SR		MCS 991		
	50 Typhoon TEC	96-00		MCB 688	EC			MCS 989		
	50 Typhoon TPH	01-		MCB 688	EC			MCS 989		
	50 Zulu C33	01-		MCB 535	EC	SR		MCB 535	EC	SR
GSM	50 Supermotard	01-		MCB 535	EC			MCB 535	EC	



Option 1

Option 2

Option 3



Option 1

Option 2

Gilera

NRG	50		94-		MCB 674	EC	SR		MCS 800		
	70 Runner SP		98-		MCB 696	EC	SR		MCB 695	EC	SR
	80 Runner		96		MCB 688	EC			MCS 989		
	80 Runner		97-		MCB 696	EC	SR		MCS 984		
	80 Typhoon		93-95		MCB 674	EC	SR		MCS 991		
	80 Typhoon		96-		MCB 688	EC			MCS 989		
	125 Apache		91-		MCB 563				MCB 539	EC	
	125 Chrono		91		MCB 572		RQ		MCB 75	RQ	
	125 Coguar	M17	99-01		MCB 557		SRM				
	125 DNA	M26	00-	Grimeca	MCB 664	SRM	EC		MCB 696	EC	SR
	125 DNA	M26	01-	Hengtong	MCB 744	SRM	EC		MCB 696	EC	SR
	125 Nexus i. e.	M35	07-		MCB 744	SRM	EC		MCB 744	SRM	EC
	125 Stalker		97-		MCB 674	EC	SR		MCB 695	EC	SR
CX	125		91		MCB 572		RQ		MCB 75	RQ	
FX	125 Runner	M07	97-98		MCB 629				MCS 994		
FX	125 Runner SP	M07	99-03	Grimeca	MCB 664	SRM	EC		MCB 827	SRM	EC
FX	125 Runner SP	M07	99-03	Hengtong	MCB 744	SRM	EC		MCB 827	SRM	EC
RC	125 Top Rally		90-		MCB 579		SI		MCB 539	SI	EC
SC	125		06-		MCB 780				MCB 535	EC	
TPH	125 Typhoon		93-95		MCB 674	EC	SR		MCS 991		
TPH	125 Typhoon	M02	96-		MCB 688	EC			MCS 984		
VX	125 Runner	M27	01-04	Hengtong	MCB 744	SRM	EC		MCB 727 SRM		
VX	125 Runner	M24	01-	Grimeca	MCB 664	SRM	EC		MCB 727 SRM		
VX	125 Runner ST	M46	05-		MCB 744	SRM	EC		MCB 727 SRM		
VX	125 Runner ST		12-		MCB 744	SRM	EC		MCB 827	SRM	EC
	180 DNA	M26	00-		MCB 664	SRM	EC		MCB 696	EC	SR
	180 Stalker		97-		MCB 674	EC	SR		MCB 827 SRM		
FXR	180 Runner	M08	97-99		MCB 629				MCS 994		
FXR	180 Runner SP	M08	00-	Grimeca	MCB 664	SRM	EC		MCB 827	SRM	EC
FXR	180 Runner SP	M08	00-	Hengtong	MCB 744	SRM	EC		MCB 827	SRM	EC
VX	180 Runner 4 T	M24	01-	Hengtong	MCB 744	SRM	EC		MCB 727 SRM		
VX	180 Runner 4T	M24	01-	Grimeca	MCB 664	SRM	EC		MCB 727 SRM		
	200 Stalker		97-		MCB 674	EC			MCB 827	SRM	EC
FX	200 Runner		97-00		MCB 629				MCS 994		
FX	200 Runner SP		98-		MCB 664 SRM		EC		MCB 827 SRM		
VX	200 Runner ST	M46	05-11		MCB 744 SRM		EC		MCB 727 SRM		
VXR	200 Runner 4 T	M24	01-	Grimeca	MCB 664 SRM		EC		MCB 727 SRM		
VXR	200 Runner 4 T	M24	01-	Hengtong	MCB 744 SRM		EC		MCB 727 SRM		
	250 Nexus i. e.	M35	06-08		MCB 744 SRM		EC		MCB 744 SRM		
	250 Oregon Quad		07-		* MCB 539 SI				MCB 732 SI		
	300 Nexus i. e.	M35	08-		MCB 744 SRM				MCB 744 SRM		
	350 Dakota, ER		89		MCB 557				MCB 75		
	500 Nexus	M35	04-		* MCB 648 SRM				MCB 700 SRM		
RC	500 Fouco i.e.	M61	07-						MCB 832 P		
RC	500 Fouco i.e.	M61	07-		MCB 827 SRM				MCB 744 SRM		
	600 Northwest		91-		MCB 572				MCB 75		
RC	600 R, Top Rally		88-		MCB 579		SI		MCB 539	SI	EC
XRT	600		89		MCB 557				MCB 75		
GP	800		08-						MCB 832 P		
GP	800		08-		* MCB 648 SRM				MCB 744 SRM		

Goes

	360 Max		08-		* MCB 863 SI						
GP	520		07-		* MCB 863 SI				MCB 756 SI		
	520 Max		07-		* MCB 863 SI				MCB 756 SI		
GP	525		12-		* MCB 863 SI				MCB 756 SI		
GP	620		11-		* MCB 863 SI				MCB 756 SI		
GP	625		12-		* MCB 863 SI				MCB 756 SI		

Harley-Davidson

	500 Street		14-		MCB 871		SV		MCB 871		SH
	700 Street		14-		MCB 871		SV		MCB 871		SH
XL	883 Sportster	XL2	04-09		MCB 753 SV				MCB 754 SH		



* 2 Sätze erforderlich – 2 sets required
 Parkbremse – Parkingbrake



ohne Verschleißanzeige – without wear indicator
 linke Seite – left side
 rechte Seite – right side



Option 1

Option 2

Option 3



Option 1

Option 2

Harley-Davidson

XL	883 C Sportster Custom	XL1	00-03		MCB 777 SV			MCB 778 SH		
XL	883 C Sportster Custom	XL2	04-10		MCB 753 SV			MCB 754 SH		
XL	883 L Low	XL2	06-10		MCB 753 SV			MCB 754 SH		
XL	883 L Super Low	XL2	11-13		MCB 753 SV			MCB 754 SH		
XL	883 L Super Low	XL2	14-		MCB 776	SV		MCB 691	SH	
XL	883 N Sportster Iron	XL2	09-13		MCB 753 SV			MCB 754 SH		
XL	883 N Sportster Iron	XL2	14-		MCB 776	SV		MCB 691	SH	
XL	883 R Sportster	XL1	02-03		MCB 777 SV			MCB 778 SH		
XL	883 R Sportster Roadster	XL2	05-13	*	MCB 753SV			MCB 754 SH		
XL	883 R Sportster Roadster	XL2	14-		MCB 776	SV		MCB 691	SH	
XLH	883 Sportster Hugger	XL1	00-03		MCB 777 SV			MCB 778 SH		
XL	883 Sportster Iron	XL2	09-		MCB 753 SV			MCB 754 SH		
XLH	883 Sportster		70-84		MCB 511					
XLH	883 Sportster		85-86		MCB 548			MCB 527		
XLH	883 Sportster	XL1	87-99		MCB 548			MCB 583		
XLH	883 Sportster	XL1	00-03		MCB 777 SV			MCB 778 SH		
XLH	1000 Sportster		79-82	*	MCB 511			MCB 518		
XLH	1000 Sportster		83-85	*	MCB 511			MCB 527		
XLS	1000 Anniversary		82	*	MCB 511			MCB 527		
XLS	1000 Roadster		79-82	*	MCB 511			MCB 518		
XLS	1000 Sportster		83-85	*	MCB 511			MCB 527		
XLX	1000 61 Sportster		83-85	*	MCB 511			MCB 527		
XR	1000		85	*	MCB 511			MCB 527		
XLH	1100 Sportster		85-86		MCB 548			MCB 527		
XLH	1100 Sportster		87-88		MCB 548			MCB 583		
XLX	1100 Sportster		86-		MCB 548			MCB 527		
VRSCA	1130 V-Rod	VR1	02-05		MCB 777 SV			MCB 778 SH		
VRSCA	1130 V-Rod	VR1	06-07		MCB 781 SV			MCB 781 SH		
VRSCB	1130 V-Rod	VR1	04-05		MCB 777 SV			MCB 778 SH		
VRSCD	1130 Night Rod	VR2	06-07		MCB 781 SV			MCB 781 SH		
VRSCDX	1130 Night Rod Special	VR2	07		MCB 781 SV			MCB 781 SH		
VRSCR	1130 Street Rod	VR2	06-07		MCB 781 SV			MCB 781 SH		
FL	1200 Electra Glide		75-79		MCB 97			MCB 97		
FLH	1200 Electra Glide		77-78		MCB 97			MCB 97		
FLHS	1200		77-80		MCB 97			MCB 97		
FX	1200 Super Glide		74-80		MCB 511			MCB 97		
FXE	1200 Super Glide		74-80		MCB 511			MCB 97		
FXS	1200 Low Rider		78-79		MCB 511			MCB 97		
XL	1200 C Sportster Custom	XL1	00-03		MCB 777 SV			MCB 778 SH		
XL	1200 C Sportster Custom	XL2	04-13		MCB 753 SV			MCB 754 SH		
XL	1200 C Sportster Custom	XL2	14-		MCB 776	SV		MCB 691	SH	
XL	1200 L Sportster Low	XL2	07-09		MCB 753 SV			MCB 754 SH		
XL	1200 N Nightster	XL2	07-12		MCB 753 SV			MCB 754 SH		
XL	1200 R Sportster Roadster	XL2	04-08		MCB 753 SV			MCB 754 SH		
XL	1200 Sportster Sport	XL1	00-03		MCB 777 SV			MCB 778 SH		
XL	1200 T Super Low		15-		MCB 776	SV		MCB 691	SH	
XL	1200 V Seventy-Two	XL2	12-13		MCB 753 SV			MCB 754 SH		
XL	1200 V Seventy-Two	XL2	14-		MCB 776	SV		MCB 691	SH	
XL	1200 X Forty-Eight	XL2	10-13		MCB 753 SV			MCB 754 SH		
XL	1200 X Forty-Eight	XL2	14-		MCB 776	SV		MCB 691	SH	
XLH	1200 Sportster	XL1	00-03	*	MCB 777 SV			MCB 778 SH		
XLH	1200 Sportster	XL1	93-99		MCB 548			MCB 583		
XR	1200	XR1	08-10	*	MCB 819 SV			MCB 754 SH		
XR	1200 X	XR1	10-12	*	MCB 819 SV			MCB 754 SH		
VRSCAW	1250 V-Rod	VR1	08-10		MCB 781 SV			MCB 781 SH		
VRSCAW	1250 V-Rod ABS	VR1	08-10		MCB 781 SV			MCB 781 SH		
VRSCDX	1250 Night Rod Special, ABS		08-		MCB 781 SV			MCB 781 SH		
VRSCF	1250 V-Rod Muscle, ABS		09-		MCB 781 SV			MCB 781 SH		
VRSCX	1250 V-Rod		07-08		MCB 781 SV			MCB 781 SH		
VRSCDX	1250 V-Rod 10th Anniversary		12		MCB 781 SV			MCB 781 SH		
FLH	1340 80		78-80		MCB 97			MCB 97		
FLH	1340 80		81		MCB 97			MCB 528		
FLH	1340 Classic		82-		MCB 518			MCB 528		
FLH	1340 Electra Glide		82-83	*	MCB 518			MCB 97		
FLH	1340 Heritage		81	*	MCB 518			MCB 528		



Option 1

Option 2

Option 3



Option 1

Option 2

Harley-Davidson

FLHS	1340 Electra Glide		90	*	MCB 548			MCB 580		
FLHT	1340 Electra Glide		85-86	*	MCB 548			MCB 527		
FLHT	1340 Electra Glide Classic		87-	*	MCB 548			MCB 583		
FLHTC	1340 Electra Glide Classic		90	*	MCB 548			MCB 580		
FLHTC	1340 Electra Glide Classic		85-86	*	MCB 548			MCB 527		
FLHTC	1340 Electra Glide Classic		98-	*	MCB 548			MCB 580		
FLHTC	1340 Ultra Classic		90	*	MCB 548			MCB 580		
FLSFT	1340 Fat Boy	FXST	90-99		MCB 548			MCB 583		
FLST	1340 Heritage Softail		86-		MCB 548			MCB 580		
FLSTC	1340 Heritage Softail Classic		90		MCB 548			MCB 583		
FLT	1340 80		80-81	*	MCB 518			MCB 528		
FLT	1340		84-85		MCB 548			MCB 528		
FLT	1340 80 Classic		81	*	MCB 518			MCB 528		
FLT	1340 Classic		82-83	*	MCB 518			MCB 528		
FLT	1340 Series		88	*	MCB 548			MCB 580		
FLT	1340 Tour Glide		82	*	MCB 518			MCB 528		
FLT/H	1340 Series		86-87	*	MCB 548			MCB 580		
FLTC	1340 Tour Glide Class		90	*	MCB 548			MCB 580		
FLTC	1340 Tour Glide Class		85-86		MCB 548			MCB 527		
FLTH	1340 Tour Glide		84	*	MCB 511			MCB 528		
FXB	1340 80		80-81		MCB 511			MCB 97		
FXB	1340 Sturgis		82	*	MCB 511			MCB 97		
FXDB	1340 Dyna Glide		91-	*	MCB 548			MCB 583		
FXDB	1340 Sturgis		91-		MCB 548			MCB 583		
FXDL	1340 Dyna Low Rider		93		MCB 548			MCB 580		
FXDWG	1340 Dyna Wide Glide		93		MCB 548			MCB 583		
FXE	1340 80		78-91		MCB 511			MCB 97		
FXE	1340		82		MCB 511			MCB 583		
FXE	1340		85-86		MCB 548			MCB 527		
FXE	1340 Super Glide		83	*	MCB 511			MCB 97		
FXEF	1340 80 Fat Boy		79-81		MCB 511			MCB 97		
FXLR	1340 Low Rider Custom		93		MCB 548			MCB 583		
FXLR	1340 Low Rider Custom		87-88		MCB 548			MCB 583		
FXR	1340		78-81		MCB 511			MCB 97		
FXR	1340		87-88		MCB 548			MCB 583		
FXR	1340 Super Glide		90		MCB 548			MCB 583		
FXR	1340 Super Glide		85-86		MCB 548			MCB 527		
FXRD	1340 Sport Glide GTE		85-86	*	MCB 548			MCB 527		
FXRS	1340 Low Glide		82	*	MCB 511			MCB 527		
FXRS	1340 Low Glide		85-86	*	MCB 548			MCB 527		
FXRS	1340 Low Rider Conv.		90	*	MCB 548			MCB 583		
FXRS	1340 Low Rider Sport		87-	*	MCB 548			MCB 583		
FXRS	1340 Super Glide II		82-83	*	MCB 511			MCB 527		
FXRT	1340 Sport Glide		90	*	MCB 548			MCB 583		
FXRT	1340 Sport Glide		85-86	*	MCB 548			MCB 527		
FXS	1340 80		79-81		MCB 511			MCB 97		
FXS	1340 Low Rider		82	*	MCB 511			MCB 97		
FXSB	1340 Low Rider		83	*	MCB 511			MCB 527		
FXST	1340 Softail		84-86	*	MCB 548			MCB 527		
FXSTC	1340 Softail Custom		85-86		MCB 548			MCB 527		
FXSTC	1340 Softail Custom		88-		MCB 548			MCB 583		
FXSTS	1340 Springer Softail		90		MCB 548			MCB 583		
FXWG	1340 80		80-81		MCB 511			MCB 97		
FXWG	1340		87-88		MCB 548			MCB 583		
FXWG	1340 Wide Glide		82	*	MCB 511			MCB 97		
FXWG	1340 Wide Glide		83	*	MCB 511			MCB 527		
FXWG	1340 Wide Glide		85-86		MCB 548			MCB 527		
FLHR/I	1450 Road King	FL1	00-06	*	MCB 777 SV			MCB 778 SH		
FLHRCI	1450 Road King Classic	FL1	00-06	*	MCB 777 SV			MCB 778 SH		
FLHRS/I	1450 Road King Custom		00-06	*	MCB 777 SV			MCB 778 SH		
FLHT/I	1450 Electra Glide Standard	FL1	00-06	*	MCB 777 SV			MCB 778 SH		
FLHTC/I	1450 Electra Glide Classic	FL1	00-06	*	MCB 777 SV			MCB 778 SH		
FLHTCUI	1450 Ultra Classic Electra G.	FL1	00-06	*	MCB 777 SV			MCB 778 SH		



* 2 Sätze erforderlich – 2 sets required
 Parkbremse – Parkingbrake



ohne Verschleißanzeige – without wear indicator



linke Seite – left side



rechte Seite – right side



Option 1

Option 2

Option 3



Option 1

Option 2

Harley-Davidson

FLHXI	1450 Street Glide		06		MCB 777 SV		MCB 778 SH
FLSTF/I	1450 Fat Boy	FS2	00-06		MCB 777 SV		MCB 778 SH
FLSTI	1450 Heritage Softail Classic	FS2	06		MCB 777 SV		MCB 799 SH
FLSTI	1450 Heritage Softail Classic	FS2	00-05		MCB 777 SV		MCB 778 SH
FLSTN/I	1450 Softail Deluxe		05-06		MCB 777 SV		MCB 778 SH
FLSTS/I	1450 Heritage Springer	FS2	00-03		MCB 548		MCB 778 SH
FLSTSC/I	1450 Softail Springer Classic		05-06		MCB 548		MCB 778 SH
FLTR/I	1450 Road Glide Classic	FL1	00-06	*	MCB 777 SV		MCB 778 SH
FXD	1450 Dyna Super Glide	FD1	00-03		MCB 777 SV		MCB 778 SH
FXDCI	1450 Dyna Super Glide Custom		05-06		MCB 777 SV		MCB 778 SH
FXDI	1450 Dyna Super Glide		04-06		MCB 777 SV		MCB 778 SH
FXDL	1450 Dyna Low Rider	FD1	00-06	*	MCB 777 SV		MCB 778 SH
FXDS	1450 Dyna Convertible	FD1	00-06	*	MCB 777 SV		MCB 778 SH
FXDWG	1450 Dyna Wide Glide	FD1	00-06		MCB 777 SV		MCB 778 SH
FXDX	1450 Dyna Super Glide Sport	FD1	00-04	*	MCB 777 SV		MCB 778 SH
FXDXI	1450 Dyna Super Glide Sport	FD1	05-06	*	MCB 777 SV		MCB 778 SH
FXDXT	1450 Dyna Super Glide T-sport	FD1	00-03	*	MCB 777 SV		MCB 778 SH
FXST/I	1450 Softail Standard	FS2	06		MCB 777 SV		MCB 799 SH
FXST/I	1450 Softail Standard	FS2	00-05		MCB 777 SV		MCB 778 SH
FXSTB/I	1450 Night Train	FS2	06		MCB 777 SV		MCB 799 SH
FXSTB/I	1450 Night Train	FS2	00-05		MCB 777 SV		MCB 778 SH
FXSTD/I	1450 Softail Deuce	FS2	06		MCB 777 SV		MCB 799 SH
FXSTD/I	1450 Softail Deuce	FS2	00-05		MCB 777 SV		MCB 778 SH
FXSTS/I	1450 Softail Springer	FS2	00-06		MCB 548		MCB 778 SH
FLHR	1584 Road King		07	*	MCB 777 SV		MCB 799 SH
FLHR	1584 Road King		08-09	*	MCB 781 SV		MCB 781 SH
FLHRC	1584 Road King Classic		07	*	MCB 777 SV		MCB 778 SH
FLHRC	1584 Road King Classic		08-10	*	MCB 781 SV		MCB 781 SH
FLHRS	1584 Road King Custom		07-	*	MCB 777 SV		MCB 778 SH
FLHRSE	1584 Road King Screaming-Eagle		07-	*	MCB 777 SV		MCB 799 SH
FLHT	1584 Electra Glide Standard		07	*	MCB 777 SV		MCB 778 SH
FLHT	1584 Electra Glide Standard		08-10	*	MCB 781 SV		MCB 781 SH
FLHTC	1584 Electra Glide Classic		08-12	*	MCB 781 SV		MCB 781 SH
FLHTCI	1584 Ultra Classic Electra Glide		07	*	MCB 777 SV		MCB 778 SH
FLHTCU	1584 Ultra Classic Electra Glide		08-10	*	MCB 781 SV		MCB 781 SH
FLHTCUSE	1584 Ultra Electra Glide S-Eagle		07-	*	MCB 777 SV		MCB 799 SH
FLHX	1584 Street Glide		07	*	MCB 777 SV		MCB 778 SH
FLHX	1584 Street Glide		08-10	*	MCB 781 SV		MCB 781 SH
FLSTC	1584 Heritage Softail Classic		07		MCB 777 SV		MCB 799 SH
FLSTC	1584 Heritage Softail Classic		08-11		MCB 813 SV		MCB 814 SH
FLSTF	1584 Fat Boy		07		MCB 777 SV		MCB 799 SH
FLSTF	1584 Fat Boy		08-11		MCB 813 SV		MCB 814 SH
FLSTFB	1584 Fat Boy Special		10-11		MCB 813 SV		MCB 814 SH
FLSTN	1584 Softail Deluxe		07		MCB 777 SV		MCB 799 SH
FLSTN	1584 Softail Deluxe		08-11		MCB 813 SV		MCB 814 SH
FLSTN	1584 Softail Springer Classic		07		MCB 548		MCB 799 SH
FLSTSB	1584 Cross Bones		08-11		MCB 548		MCB 814 SH
FLTR	1584 Road Glide		08	*	MCB 781 SV		MCB 781 SH
FLTRU	1584 Road Glide Ultra		11-	*	MCB 781 SV		MCB 781 SH
FLTRX	1584 Road Glide Custom		10-	*	MCB 781 SV		MCB 781 SH
FXCW	1584 Rocker		08-09		MCB 813 SV		MCB 814 SH
FXCWC	1584 Rocker C		08-11		MCB 813 SV		MCB 814 SH
FXDB	1584 Dyna Street Bob		07		MCB 777 SV		MCB 778 SH
FXDB	1584 Dyna Street Bob, ABS		08-		MCB 813 SV		MCB 814 SH
FXDC	1584 Dyna Super Glide Custom		07		MCB 777 SV		MCB 778 SH
FXDCI	1584 Dyna Super Glide Custom, ABS		08-		MCB 813 SV		MCB 814 SH
FXDF	1584 Fat Bob		08-12	*	MCB 813 SV		MCB 814 SH
FXDL	1584 Dyna Low Rider		07		MCB 777 SV		MCB 778 SH
FXDL	1584 Dyna Low Rider		08		MCB 813 SV		MCB 814 SH
FXDWG	1584 Dyna Wide Glide		07		MCB 777 SV		MCB 778 SH
FXDWG	1584 Dyna Wide Glide		08-12		MCB 813 SV		MCB 814 SH
FXS	1584 Black Line, ABS		11-		MCB 813 SV		MCB 814 SH
FXST	1584 Softail Standard		07		MCB 777 SV		MCB 799 SH
FXST	1584 Softail Standard		08-		MCB 813 SV		MCB 814 SH
FXSTB	1584 Night Train		07		MCB 777 SV		MCB 799 SH



Option 1

Option 2

Option 3



Option 1

Option 2

Harley-Davidson

FXSTB	1584 Night Train	08-09		MCB 813 SV				MCB 814 SH		
FXSTBIC	1584 Night Creeper	07-		MCB 777 SV				MCB 799 SH		
FXSTC	1584 Softail Custom	07		MCB 777 SV				MCB 799 SH		
FXSTC	1584 Softail Custom	08-09		MCB 813 SV				MCB 814 SH		
FLD	1690 Dyna Switchback, ABS	10-		MCB 813 SV				MCB 814 SH		
FLHRC	1690 Road King 110 TH, ABS	13-		MCB 781 SV				MCB 781 SH		
FLHRC	1690 Road King Classic	11-		MCB 781 SV				MCB 781 SH		
FLHTCU	1690 Electra Glide Classic	11-12		MCB 781 SV				MCB 781 SH		
FLHTCU	1690 Electra Glide Ultra Limited, ABS	10-		MCB 781 SV				MCB 781 SH		
FLHTCU	1690 Ultra Classic Electra Glide, ABS	11-		MCB 781 SV				MCB 781 SH		
FLHTCUL	1690 Electra Glide Ultra Classic Low	15-	*	MCB 781 SV				MCB 781 SH		
FLHTCUTG	1690 Tri Glide Ultra	14-	*	MCB 865 SV				MCB 866 SH		
FLHTCUTG	1690 Tri Glide Ultra Classic	09-	*	MCB 781 SV						
FLHTCUTG	1690 Tri Glide Ultra Classic Trike	09-13	*	MCB 781 SV				MCB 864 SH		
FLHTKL	1690 Ultra Limited Low	15-	*	MCB 781 SV				MCB 781 SH		
FLHXS	1690 Street Glide Special, ABS	14-	*	MCB 781 SV				MCB 781 SH		
FLHXXX	1690 Street Glide Trike	10-	*	MCB 781 SV				MCB 864 SH		
FLHXXX	1690 Street Glide, ABS	11-	*	MCB 781 SV						
FLRT	1690 Freewheeler	15-	*	MCB 865 SV				MCB 866 SH		
FLS	1690 Softail Slim, ABS	12-		MCB 813 SV				MCB 814 SH		
FLSTC	1690 Heritage Softail Classic, ABS	12-		MCB 813 SV				MCB 814 SH		
FLSTF	1690 Fat Boy, Fat Boy Special, ABS	12-		MCB 813 SV				MCB 814 SH		
FLSTN	1690 Softail Deluxe, ABS	12-		MCB 813 SV				MCB 814 SH		
FLTRX	1690 Road Glide	15-	*	MCB 781 SV				MCB 781 SH		
FLTRXS	1690 Road Glide Special ABS	15-	*	MCB 781 SV				MCB 781 SH		
FXDB	1690 Dyna Street Bob	14-		MCB 813 SV				MCB 814 SH		
FXDC	1690 Dyna Super Glide Custom	14-		MCB 813 SV				MCB 814 SH		
FXDF	1690 Fat Bob, ABS	13-	*	MCB 813 SV				MCB 814 SH		
FXDL	1690 Dyna Low Rider	14-	*	MCB 813 SV				MCB 814 SH		
FXDWG	1690 Dyna Wide Glide, ABS	13-		MCB 813 SV				MCB 814 SH		
FXSB	1690 Breakout, ABS	13-		MCB 813 SV				MCB 814 SH		
FLHTCU	1800 CVO Ultra Classic Electra Gl., ABS	11-	*	MCB 781 SV				MCB 781 SH		
FLHTKSE	1800 CVO Limited	14-	*	MCB 781 SV				MCB 781 SH		
FLHRCSE	1800 CVO Road King, ABS	13-	*	MCB 781 SV				MCB 781 SH		
FLHX	1800 CVO Street Glide	10-12	*	MCB 781 SV				MCB 781 SH		
FLSTNSE	1800 CVO Softail Deluxe, ABS	14-	*	MCB 813 SV				MCB 814 SH		
FLSTSE	1800 CVO Softail Convertible	10-12		MCB 813 SV				MCB 814 SH		
FLTR	1800 CVO Road Glide Custom, ABS	11-	*	MCB 781 SV				MCB 781 SH		
FLTRUSE	1800 CVO Road Glide Ultra	11-	*	MCB 781 SV				MCB 781 SH		
FXDSE	1800 Dyna Screaming Eagle	07-08		MCB 777 SV				MCB 799 SH		
FXSTSSE	1800 Softail Springer S-Eagle	07-08		MCB 548				MCB 799 SH		
FXSBSE	1800 CVO Breakout, ABS	13-		MCB 781 SV				MCB 781 SH		

Hercules

	50 Gipsy, Splinter, Reggae	FE053DE	95-	MCB 674	EC	SR				
K	50 Ultra LC		79-83	* MCB 508						
KX	50			MCB 508						
KX-5	50		87-	* MCB 508						
RS	50		79-83	* MCB 508						
Supra	50 4 GP		80-	MCB 517						
ZX-1	50		86-	MCB 578						
RX-9	80		82-83	MCB 508						
Ultra	80		81-83	* MCB 508						
	280 ATV		07-	* MCB 760 SI						
	300 ATV Sport		07-	* MCB 760 SI						

Highland

	950 V2 Motard		00-	MCB 648 SI	RSI	EC		MCB 672 SI	RSI	EC
	950 V2 Outback		99-	MCB 648 SI	RSI	EC		MCB 672 SI	RSI	EC

HM

	125 Supermotard		00-	MCB 669 SI	RSI	EC		MCB 575 SI	RSI	EC
	250 Supermotard		00-	MCB 669 SI	RSI	EC		MCB 575 SI	RSI	EC



* 2 Sätze erforderlich – 2 sets required
Parkbremse – Parkingbrake



ohne Verschleißanzeige – without wear indicator



linke Seite – left side



rechte Seite – right side



Option 1

Option 2

Option 3



Option 1

Option 2

Honda										
CB	50 J	CB50J	-80		MCS 804				MCS 804	
CB	50 J	CB50J	81-83		MCB 504				MCS 804	
CHF	50 SCOOPY		03-08		MCB 674	EC			MCS 800	
CRF	50		04-		MCS 827				MCS 827	
CY	50	CY50	80-83		MCS 800				MCS 800	
MB	50 S	AC01	80-		MCB 510	SI			MCS 804	
MBX	50 SD	AC05	83-		MCB 525	EC			MCS 804	
MT	50 S	AD01	80-		MCS 804				MCS 804	
MTX	50 S	AD04	83-		MCS 804				MCS 804	
NB	50 M	AB07	84-		MCS 827				MCS 813	
NCZ	50	AB12	81		MCS 827				MCS 827	
NH	50 Lead	AF01	86-93		MCS 800				MCS 813	
NH	50 Lead	AF01	94-		MCB 665	EC			MCS 813	
NH	50 Lead	AF01	94-	☹ ()	MCS 800				MCS 813	
NPS	50 Zoomer		01-		MCS 825				MCS 825	
NS	50 M		82-84		MCS 827				MCS 825	
NS-1	50		91-		MCB 525	EC				
NSC	50 AC Vision	AF72	12-	16"	MCB 833	EC	SRM		MCS 835	
NSR	50		93-		MCB 615	EC			MCS 804	
NSR	50 S	AC08	89-92		MCB 525	EC			MCS 804	
NSR	50		93-	Japan	MCB 525	EC			MCB 575	
NVS	50 Today		03-09		MCS 825				MCS 839	
PA	50 STD		86-		MCS 828				MCS 828	
PK	50 DX Wallaroo	AB25	90-		MCS 825				MCS 800	
PX	50 MS	AB06S	84-		MCS 828					
QR	50 D-L		93-90		MCS 827				MCS 825	
QR	50 M-Y		91-		MCS 827				MCS 825	
SA	50 Vision	AF29	85-87		MCS 827					
SA	50 Vision	AF29	88-94		MCS 825				MCS 825	
SFX	50 Sport	AF37	96-		MCB 674	EC	SR		MCS 800	
SGX	50 sky	AF43	97-		MCB 674	EC	SR		MCS 800	
SGX	50 sky DX	AF43	00-		MCB 674	EC	SR		MCS 800	
SH	50 Fifty	AF40	00-		MCB 674	EC	SR		MCS 800	
SH	50 Scoopy	AF40	96-		MCB 674	EC	SR		MCS 800	
SJ	50 Bali	AF32	93-99		MCB 673	EC			MCS 800	
SK	50 Dio	AF18	90-		MCS 825				MCS 825	
SRX	50 Shadow	AF42	98-		MCB 575	SR			MCS 800	
ST	50	AB23A	96-		MCS 800				MCS 800	
ST	50 Dax	ST50	78-87		MCS 800				MCS 800	
ST	50 Dax	AB23	88-93		MCS 800				MCS 800	
SZX	50 X8R-S, X8R-X	AF49	98-		MCB 674	EC	SR		MCB 686	
XL	50	XL50	79-		MCS 804				MCS 804	
XR	50 R		00-		MCS 827				MCS 827	
Z	50 A	Z50A	71-79		MCS 800				MCS 800	
Z	50 J-Z	AB02	77-81		MCS 800				MCS 800	
Z	50 R, C-X	AB02	82-99		MCS 827				MCS 827	
ZB	50 P	AB22	88-		MCB 589				MCS 827	
CR	60 F		85		MCS 855				MCS 855	
CRF	70		04-		MCS 855				MCS 855	
ST	70 K3				MCS 800				MCS 800	
TRX	70 Fourtrax		86-87		MCS 837					
XR	70		97-03		MCS 855				MCS 855	
CRM	75			☹ ☐	MCB 574 SI	RSI			MCB 575 SI	EC
CRM	75			☹ ()	MCB 574 SI	RSI			MCS 804	
NS-1	75		92-		MCB 663				MCB 575	EC
XL	75		77-80		MCS 804				MCS 804	
XR	75 K		77-79						MCS 804	
	80 Cityfly		99-		MCB 577					
CB	80	HC03	80-		MCS 804				MCS 804	
CR	80 R		82		MCS 804				MCS 825	
CR	80 R		80-82		MCS 804				MCS 825	
CR	80 R		83-84		MCS 825				MCS 825	
CR	80 R		85		MCS 804				MCS 804	
CR	80 R		86-91		MCB 554 SI				MCS 804	
CR	80 R	HE04	92-02		MCB 554 SI				MCB 575 SI	RSI EC



Option 1

Option 2

Option 3



Option 1

Option 2

Honda

CRF	80		04-		MCS 855				MCS 855		
CY	80	CY 80	79-		MCS 800				MCS 800		
MB	80 S	HC01	80-		MCB 522				MCS 804		
MBX	80 SW	HC04	83-		MCB 525	EC			MCS 804		
MBX	80 SW2	HC04	83-87		MCB 510	SI			MCS 804		
MBX	80 SWD	HC04	83-84		MCB 525	EC			MCS 804		
MBX	80 SWD	HC04	85-		MCB 510	SI			MCS 804		
MBX	80 SWZ	HC04	83-84		MCB 525	EC			MCS 804		
MCX	80 S	HC05	83-		MCB 522				MCS 804		
MT	80 S	HD02	80-		MCS 804				MCS 804		
MTX	80 C	HD06	82-		MCS 804				MCS 804		
MTX	80 R2	HD09	87-		MCB 534	SI			MCS 804		
MTX	80 RS	HD08	83-84		MCS 804				MCS 804		
NH	80 Lead	HF01	83-84		MCS 800				MCS 813		
NH	80 Lead	HF01	85-		MCB 589				MCS 813		
NSR	80 R		87-92		MCB 525	EC			MCB 575	EC	
XR	80 R		79-84		MCS 804				MCS 804		
XR	80 R		85-		MCS 855				MCS 855		
CR	85 R		03-07		MCB 554 SI				MCB 575 SI	EC	
CT	90		71-77		MCS 804				MCS 804		
NH	90 Yupy	AF01	90-94		MCB 575	SR			MCS 800		
SRX	90 Shadow	HF09A	98-		MCB 575	SR			MCS 800		
CRF	100		04-12		MCS 855				MCS 855		
SCV	100 Lead	JF11	00-		MCB 534	SRM			MCS 835		
SH	100 Scoopy		96-		MCB 674	EC	SR		MCS 800		
SJ	100 Bali	HF07	97-		MCB 673	EC			MCS 800		
XL	100 K		74-83		MCS 804				MCS 804		
XR	100 R		85-		MCS 855				MCS 855		
AFS	110 Wave	JF51	12-		MCB 872						
CRF	110		13-		MCS 855				MCS 855		
CT	110 X		05-09		MCS 804				MCS 835		
CT	110 X		80-		MCS 804				MCS 804		
NSC	110 C Vision, AC Vision	JF31	11-		MCB 833	EC	SRM		MCS 835		
SCV	110 NHX Lead	JF19	08-09		MCB 685	SRM			MCS 835		
SCV	110 NHX Lead	JF19	10-11		MCB 833	EC	SRM		MCS 835		
ANF	125 Innova	JC33	03-06		MCB 759	EC			MCS 800		
ANF	125 Innova	JC37	07-12		MCB 759	EC			MCS 800		
ATC	125 M		84-85		MCS 800						
CA	125 Rebel	JC24	95-96		MCB 689				MCS 805		
CA	125 Rebel	JC26	97-03		MCB 557				MCS 805		
CB	125 F		14-		MCB 615	EC					
CB	125 J	CB125J	75-81		MCB 504				MCS 804		
CB	125 K6		76-						MCS 817		
CB	125 T	CB125T	78-79		MCB 504				MCS 817		
CB	125 T2,T	CB125T	80-81		MCB 502				MCS 817		
CB	125 TD	JC06	82-		MCB 512				MCS 817		
CBF	125	JC40A	09-		MCB 759	EC			MCS 835		
CBR	125 R	JC34	04-06		MCB 759	EC			MCB 738		
CBR	125 R	JC39	07-10		MCB 759	EC			MCB 738		
CBR	125 R	JC50	11-		MCB 759	EC			MCB 738		
CG	125		04-		MCB 510				MCS 835		
CG	125		85-04		MCS 819				MCS 800		
CH	125 Spacy	JF03A	83-84		MCS 800				MCS 800		
CH	125 Spacy	JF03A	94-		MCB 685	SRM			MCS 819		
CLR	125 Cityfly	JD18B	99-		MCB 557	SRM			MCS 804		
CM	125 C	JC05	82-		MCS 803				MCS 817		
CR	125 M		76-78		MCS 804				MCS 804		
CR	125 R	JE01	79-81						MCS 819		
CR	125 R	JE01	82		MCS 819				MCS 819		
CR	125 R	JE01	83								
CR	125 R	JE01	84-85		MCB 534	SI					
CR	125 R	JE01	86		MCB 534	SI					
CR	125 R	JE01	87-94		MCB 574 SI	RSI			MCB 575 SI	RSI	EC



* 2 Sätze erforderlich – 2 sets required
Parkbremse – Parkingbrake



ohne Verschleißanzeige – without wear indicator



linke Seite – left side



rechte Seite – right side



Option 1

Option 2

Option 3



Option 1

Option 2

Honda											
CR	125 R	JE01	95-01		MCB 669 SI	RSI	EC		MCB 575 SI	RSI	EC
CR	125 R	JE01	02-07		MCB 669 SI	RSI	EC		MCB 730 SI		EC
CRE	125		02-	HM	MCB 669 SI	RSI	EC		MCB 730 SI		EC
CRF	125		14-		MCB 669 SI	RSI	EC		MCS 825		
CRM	125		90-97		MCB 557				MCB 623		
CT	125 K		89-94		MCS 804				MCS 804		
FES	125 Pantheon	JF05	98-02		MCB 693 SRM				MCS 995		
FES	125 Pantheon	JC12	03-06		MCB 693 SRM				MCB 585 SRM		
FES	125 S-Wing	JF12	07-		MCB 776 SRM				MCB 806 SRM		
FES	125 S-Wing ABS	JF12	07-		MCB 776 SRM				MCB 806 SRM		
FS	125 Sonic		03-		MCB 525	EC					
MBX	125 RW		84		MCB 551				MCS 804		
MSX	125	JC61	13-		MCB 759				MCB 867		
MTX	125 RW		83-84		MCS 804				MCS 804		
MTX	125 RW		85-		MCB 534	SI			MCS 804		
NES	125 @	JF07	01-		MCB 534	SRM			MCS 805		
NH	125 Lead	JF01	83-85		MCS 800				MCS 800		
NH	125 Lead	JF01	86-87		MCB 589				MCS 800		
NS	125 F		86-93		MCB 557				MCS 800		
NSS	125 Forza		15-		MCB 598 SRM				MCB 806 SRM		
NSR	125 R	JC22	88-03		MCB 557				MCB 623		
NX	125 Transcity	JD12	89		MCB 574	SI	RSI		MCS 800		
NX	125 Transcity	JD12	90-98		MCB 557				MCS 800		
PCX	125	JF28	10-12		MCB 833	EC	SRM		MCS 819		
PCX	125	JF47	13-		MCB 833	EC	SRM		MCS 819		
PS	125 i	JF17	07-		MCB 685	SRM			MCS 835		
RS	125 R		90		MCB 598	SV	SRQ		MCB 589		
RS	125 R		88-89		MCB 571	SV			MCB 589		
RS	125 R	JF05	91-94		MCB 598	SV	SRQ		MCB 585	SH	
RS	125 R	JF05	95-		MCB 540 SV	SRQ	CRQ		MCB 589		
SES	125 Dylan	JF10	02-06		MCB 685	SRM			MCS 835		
SH	125 i	JF09	01-04		MCB 534	SRM			MCS 835		
SH	125 i	JF14	05-08		MCB 534	SRM			MCS 835		
SH	125 i	JF23	09-12		MCB 776	SRM			MCB 806 SRM		
SH	125 i	JF41	13-		MCB 598	SRM			MCB 806 SRM		
SL	125		76-80		MCS 804				MCS 804		
VT	125 C Shadow	JC29	99-00		MCB 663				MCS 805		
VT	125 C Shadow	JC31	01-08		MCB 663				MCS 805		
XL	125	XL125	72		MCS 804				MCS 804		
XL	125	XL125	73-74		MCS 800				MCS 804		
XL	125 R	KF06	85-91		MCB 534	SI			MCS 804		
XL	125 S		79-82		MCS 804				MCS 804		
XLR	125	JD	93-		MCB 574	SI	RSI		MCB 575 SI	RSI	EC
XLR	125 R	JD16	98-99		MCB 574	SI	RSI		MCS 804		
XLV	125 Varadero	JC32	01-10		MCB 663				MCB 738		
XLV	125 Varadero	JC49	11-		MCB 663				MCB 738		
XR	125 L	JD19	03-08		MCB 669	SV	EC		MCS 804		
CRF	150 R	CRF150	07-12		MCB 561 SI	EC			MCB 730 SI	RSI	EC
FES	150 Pantheon	JF05	98-02		MCB 693 SRM				MCS 995		
FES	150 Pantheon	KF06	03-06		MCB 693 SRM				MCB 585 SRM		
FES	150 Silver Wing, ABS	KF06	07-09		MCB 776 SRM				MCB 806 SRM		
NES	150 @	KF03	01-		MCB 534	SRM			MCS 835		
NSR	150		02-		MCB 663	EC			MCB 582		
PCX	150		10-		MCB 833	EC	SRM		MCS 819		
PS	150 i	KF09	06-10		MCB 685	SRM			MCS 835		
SES	150 Dylan	JF10	02-		MCB 685	SRM			MCS 835		
SH	150	KF04	02-		MCB 534	SRM			MCS 835		
SH	150 i	KF10	09-12		MCB 776	SRM			MCB 806 SRM		
SH	150 i	KF10	13-		MCB 598	SRM			MCB 806 SRM		
CD	175		71-78						MCS 843		
CM	185 T	CM185T	78-82		MCS 803				MCS 817		
XL	185 S	L185S	79-99		MCS 804				MCS 804		
CB	200 B	CB200	81						MCS 811		
CM	200 T	MC01	80-81		MCS 803				MCS 817		
CT	200 E-K		84-89		MCS 804				MCS 804		



Option 1

Option 2

Option 3



Option 1

Option 2

Honda

CT	200 P		93-99		MCS 804				MCS 804		
MTX	200 RW	MD07	83-84		MCS 804				MCS 804		
MTX	200 RW	MD07	85-		MCB 534	SI			MCS 804		
TRX	200 Fourtrax		90-93	*	MCS 836						
TRX	200 SX		86-87	*	MCS 836						
XL	200 R	MD06	83-		MCS 804				MCS 804		
XR	200		81-83		MCS 804				MCS 804		
	250 Jazz	MF07	01-04		MCB 704 SRM						
ATC	250 R	ATC250	81	*	MCB 510 SI						
ATC	250 R	ATC250	85	*	MCB 534 SI				MCB 538 SI		
ATC	250 R	ATC250	82-84	*	MCB 554 SI				MCB 538 SI		
ATC	250 R	ATC250	85-86	*	MCB 534 SI				MCB 534 SI		
CB	250 F Hornet	MC31	96-01		MCB 593	SV	SRQ		MCB 585	SH	
CB	250 G	CB250	74-76		MCB 35				MCS 802		
CB	250 N	CB250N	79-82		MCB 55				MCS 807		
CB	250 RS	MC02	80-84		MCB 55				MCS 811		
CB	250 RS	MC02	85-		MCB 534				MCS 811		
CB	250 T2	CB250T	79-		MCB 55				MCS 807		
CB	250 Two-fifty	MC26	92-05		MCB 598	SV			MCS 817		
CBF	250		04-		MCB 663				MCS 835		
CBR	250 R	MC41	11-		MCB 598	SV	SRQ		MCB 841	SH	
CBR	250 R ABS	MC41	11-		MCB 776	SV			MCB 841	SH	
CBR	250 R, RR	MC19/MC22	88-94		MCB 598	SV	SRQ		MCB 585	SH	
CBX	250 F		85-88		MCB 525	EC			MCS 804		
CD	250 U		92-98		MCB 624				MCS 804		
CH	250 Spacy		85-		MCB 534				MCS 820		
CJ	250 T	CJ250T	77-78		MCB 35				MCS 802		
CL	250 S	MD04	82-		MCS 803				MCS 811		
CM	250 C	MC06	82-		MCS 803				MCS 817		
CMX	250 Rebel	MC13B	96-97		MCB 689				MCS 817		
CMX	250 Rebel	MC13B	98-		MCB 673				MCS 817		
CN	250		93-		MCB 544				MCS 819		
CN	250 Helix	MF02	88-92		MCB 544				MCS 831		
CN	250 Helix-Fusion	MF02	92		MCB 544				MCS 820		
CR	250 R	ME03	81-83						MCS 819		
CR	250 R	ME03	84-85		MCB 534 SI						
CR	250 R	ME03	86		MCB 534 SI						
CR	250 R	ME03	87-94		MCB 574 SI	RSI			MCB 575 SI	RSI	EC
CR	250 R	ME03	95-01		MCB 669 SI	RSI	EC		MCB 575 SI	RSI	EC
CR	250 R	ME03	02-07		MCB 669 SI	RSI	EC		MCB 730 SI	RSI	EC
CRE	250	ME11	02-		MCB 669 SI	RSI	EC		MCB 730 SI	RSI	EC
CRF	250 L	ME11	12-		MCB 818				MCB 867 SI		
CRF	250 R, X	ME11	04-		MCB 669 SI	RSI	EC		MCB 730 SI	RSI	EC
CRM	250 R		89-90		MCB 574 SI	RSI			MCB 601		
CRM	250 R		91-		MCB 574 SI	RSI			MCB 575 SI	RSI	EC
EX	250 Sportrax		01-	*	MCB 561 SI		EC				
FES	250 Foresight	MF04	98-99		MCB 693 SRM				MCS 995		
FES	250 Foresight	MF04	98-99	P					MCS 995		
FES	250 Foresight	MF05	00-05		MCB 693 SRM				MCB 585 SRM		
FES	250 Foresight	MF05	00-05	P					MCS 995		
NSR	250 R	MC16	87	*	MCB 562 SV	SRQ			MCB 512	SH	
NSR	250 R	MC18	88-89	*	MCB 593 SV	SRQ	CRQ		MCB 585	SH	
NSR	250 R	MC21	90-93	*	MCB 593 SV	SRQ	CRQ		MCB 585	SH	
NSR	250 R	MC28	94-97	*	MCB 593 SV	SRQ	CRQ		MCB 594		
NSS	250 Forza	MF06	00-04		MCB 704	SRM			MCB 634		
NSS	250 Forza	HF08	05-06		MCB 776	SRM			MCB 806 SRM		
NSS	250 Forza ABS	HF08	05-06		MCB 776	SRM			MCB 806 SRM		
NX	250	MD21	88-90		MCB 574	SI	RSI		MCS 812		
NX	250	MD25	91-95		MCB 574	SI	RSI		MCS 812		
PS	250 Ruckus	MF09	05-06		MCB 776	SRM			MCS 995		
RS	250 R		90-93	*	MCB 598 SV	SRQ			MCB 585	SH	
RS	250 R		91-		MCB 593 SV	SRQ	CRQ		MCB 585	SH	
RS	250 R		94-		MCB 540 SV	SRQ	CRQ		MCB 589		



* 2 Sätze erforderlich – 2 sets required
 Parkbremse – Parkingbrake



ohne Verschleißanzeige – without wear indicator



linke Seite – left side



rechte Seite – right side



Option 1

Option 2

Option 3



Option 1

Option 2

Honda										
SL	250 Y		02-05		MCB 669 SI	RSI	EC		MCB 665	
TRX	250 EX Sporttrax		01-08	*	MCB 561SI				MCS 821	
TRX	250 V/W/X/Y	TRX250	97-12	*	MCS 836				MCS 821	
VTR	250	MC15	98-		MCB 677				MCB 585	SH
XL	250	L250	73-74						MCS 804	
XL	250 R	MD03	82-83		MCS 819				MCS 812	
XL	250 R	MD11	84-93		MCB 534	SI			MCS 804	
XL	250 R Baja	MD11	88-91		MCB 574	SI	RSI		MCB 575	SI RSI
XL	250 S	L250S	79-81		MCS 803				MCS 812	
XLR	250 R		94-		MCB 669	SI	RSI		MCB 575	SI RSI
XR	250 L (E-starter)		02-07		MCB 669	SI	RSI EC		MCB 575	SI EC
XR	250 R		81-83						MCS 812	
XR	250 R	ME06	84-87		MCB 534	SI			MCS 804	
XR	250 R, RK	ME06	88-93		MCB 574	SI	RSI		MCB 575	SI EC
XR	250 S, R	ME06	94-		MCB 669	SI	RSI EC		MCB 575	SI EC
	260 Cota 4RT		14-	HM	MCB 766				MCB 767	
CB	300		09-		MCB 663				MCS 835	
CBR	300 F	NC51	14-		MCB 677	SV			MCB 841	SH SRQ
CBR	300 R		15-		MCB 677	SV			MCB 841	SH SRQ
NSS	300 Forza	NF04	13-		MCB 776 SRM				MCB 806 SRM	
NSS	300 Forza ABS	NF04	13-		MCB 776 SRM				MCB 806 SRM	
SH	300 i	NF02	07-14		MCB 776 SRM				MCB 806 SRM	
SH	300 i ABS	NF02	07-14		MCB 776 SRM				MCB 806 SRM	
SH	300 i ABS		15-		MCB 598 SRM				MCB 806 SRM	
TRX	300 EX Sporttrax	TE19	93-08	*	MCB 561 SI				MCB 561 SI	
TRX	300 FW		88-00	*	MCS 837				MCS 802	
TRX	300		88-00	*	MCS 836					
XR	300		10-		MCB 669	SI	RSI		MCB 575	SI RSI
ATC	350 X		85	*	MCB 534 SI				MCB 538 SI	
ATC	350 X		86-	*	MCB 574 SI				MCB 538 SI	
CB	350 F, F1	CB350F	73-76		MCB 35				MCS 802	
TRX	350 FE,TE, Fourtrax		00-06	*	MCS 837				MCS 995	
TRX	350 G-N		86-93		MCS 823				MCS 823	
XL	350 R	ND03	85-87		MCB 534	SI			MCS 812	
XR	350 R	ND03	84-90		MCB 534	SI			MCS 804	
XR	350 RD	NE01	84						MCS 804	
CB	360 G	CB360	73-76		MCB 35				MCS 802	
CJ	360 T	CJ360T	76-78		MCB 35				MCS 807	
CB	400 A	CB400N	77-81		MCB 55				MCS 807	
CB	400 F	CB400F	75-77		MCB 35				MCS 802	
CB	400 Four	CB400F	81-	*	MCB 512	SV			MCS 807	
CB	400 Four	NC36	97-98	*	MCB 598	SV			MCB 585	SH
CB	400 N	CB400N	78-81	*	MCB 54				MCS 807	
CB	400 N	CB400N	82-	*	MCB 512	SV			MCS 807	
CB	400 Super Four		08-	*	MCB 703 SV	SRQ			MCB 634	SH
CB	400 Super Four ABS		08-	*	MCB 776	SV			MCB 634	SH
CB	400 Super Four S	NC31	97-	*	MCB 698				MCB 585	
CB	400 Twin	CB400T	77-81		MCB 55				MCS 807	
CB	400 Twin	CB400T	82-		MCB 512	SV			MCS 807	
CB-1	400 F	NC27	89-90		MCB 598 SV	SV	SRQ		MCB 585	SH
CBR	400 RR	NC23	87-89		MCB 677				MCB 585	SH
CBR	400 RR	NC29	89-	*	MCB 598 SV	SV	SRQ		MCB 585	SH
CM	400 T	NC01	79-81		MCB 55				MCS 807	
CM	400 T	NC01	82-		MCB 512	SV			MCS 807	
FJS	400 Silver Wing	NF01	06-08		MCB 704 SRM				MCB 764 SRM	
FJS	400 Silver Wing	NF01	06-08	Ⓟ					MCB 832 P	
NSR	400 R	NC19	85-	*	MCB 544				MCB 512	
RVF	400 RR	NC35	90-96	*	MCB 593	SV	SRQ		MCB 594	
SW-T	400 D Silverwing	NF03	09-10		MCB 776	SRM			MCB 631	SH
SW-T	400 D Silverwing	NF03	09-10	Ⓟ					MCB 832 P	
SW-T	400 A Silverwing ABS	NF03	09-12		MCB 776	SRM			MCB 631	SH
SW-T	400 A Silverwing ABS	NF03	09-12	Ⓟ					MCB 832 P	
TRX	400 EX Sporttrax	TE23	99-	*	MCB 561 SI	EC			MCB 561 SI	EC
TRX	400 FA, Fourtrax		04-07		MCS 837				MCS 995	
TRX	400 FGA, Fourtrax Rancher		04-07		MCS 837				MCS 995	



Option 1

Option 2

Option 3



Option 1

Option 2

Honda

TRX	400 FW		95-00						MCS 837						MCS 995		
VFR	400 R	NC24	88			*			MCB 562	SV	SRQ				MCB 585	SH	
VFR	400 R	NC21	85-87			*			MCB 562	SV	SRQ				MCB 585	SH	
VFR	400 R	NC30	89-			*			MCB 593	SV	SRQ	CRQ			MCB 594		
XR	400 R	NE03	96-03						MCB 669	SI	RSI	EC			MCB 575 SI	RSI	EC
XR	400 Supermotard		00-						MCB 669	SI	RSI	EC			MCB 575 SI	RSI	EC
TRX	420 Fourtrax Rancher AT		09-			*			MCB 561 SI						MCB 769 SI		
XR	440 R		00-						MCB 669 SI	RSI	EC				MCB 575 SI	RSI	EC
CB	450		73-74						MCB 32						MCS 809		
CB	450		75-77						MCB 35						MCS 809		
CB	450 N	PC14	84-85						MCB 537						MCS 807		
CB	450 N	PC14	86-						MCB 570						MCS 807		
CB	450 S	PC17	86-89			*			MCB 562						MCS 807		
CRE	450	HM-Italy							MCB 669 SI	RSI	EC				MCB 730 SI	RSI	EC
CRF	450 R, X	PE05	02-08						MCB 669 SI	RSI	EC				MCB 730 SI	RSI	EC
CRF	450 R, X		09-						MCB 669 SI	RSI	EC				MCB 730 SI	RSI	EC
CRM	450	HM-Italy	07-			4			MCB 794 SRQ	RSI					MCB 730 SI	RSI	EC
EX	450 Sporttrax		01-			*			MCB 561 SI	EC					MCB 561 SI	EC	
TRX	450 FM, FE		02-04						MCS 837								
TRX	450 R, ER	TE22	04-			*			MCB 669	SI	EC				MCB 769 SI		
TRX	450 S, ES		98-02						MCS 837								
CRE	490 F	HM-Italy	07-						MCB 669 SI	RSI	EC				MCB 730 SI	RSI	EC
CB	500	PC26	94-96						MCB 598	SV					MCS 806		
CB	500 , F	CB500	70-77						MCB 35						MCS 809		
CB	500 F	PC45	13-						MCB 677	SV					MCB 841	SH	
CB	500 FA ABS	PC45	13-						MCB 677	SV					MCB 841	SH	
CB	500 S	PC32	97-						MCB 671	SV					MCB 672	SH	
CB	500 T		75						MCB 35						MCS 809		
CB	500 X	PC46	13-						MCB 677	SV					MCB 841	SH	
CB	500 XA ABS	PC46	13-						MCB 677	SV					MCB 841	SH	
CBF	500	PC39	04						MCB 677	SV					MCB 634	SH	
CBF	500 ABS	PC39	04-07						MCB 776	SV					MCB 634	SH	
CBR	500 R	PC44	13-						MCB 677	SV	SRQ				MCB 841	SH	
CBR	500 RA ABS	PC44	13-						MCB 677	SV	SRQ				MCB 841	SH	
CR	500 E	PE02	02-						MCB 669 SI	RSI	EC				MCB 575 SI	RSI	EC
CR	500 R	PE02	84-85						MCB 534 SI								
CR	500 R	PE02	86						MCB 534 SI								
CR	500 R	PE02	87-94						MCB 574 SI	RSI					MCB 575 SI	RSI	EC
CR	500 R	PE02	95-01						MCB 669 SI	RSI	EC				MCB 575 SI	RSI	EC
CX	500	CX 500	79-81			*			MCB 54						MCS 806		
CX	500 C	PC01	80-81			*			MCB 54						MCS 806		
CX	500 E	PC06	82-						MCB 544						MCB 544		
CX	500 TC	PC03	82-			*			MCB 512	SV					MCB 544		
FT	500 C	PC07	82-						MCB 512	SV					MCB 512	SH	
GB	500 Clubmann	PC16	88-						MCB 512	SV					MCS 821		
GL	500 D	PC02	81-85			*			MCB 512	SV					MCS 806		
NX	500 Dominator		88-89	AT market					MCB 624	SV					MCB 585	SH	
NX	500 Dominator		90-95	AT market					MCB 571	SV					MCB 585	SH	
NX	500 Dominator		96-01	AT market					MCB 671	SV					MCB 672	SH	EC
TRX	500 Fourtrax		01-04						MCS 837						MCS 822		
TRX	500 Fourtrax		05-			*			MCB 823 SI						MCS 806		
VF	500 F	PC12	84-86			*			MCB 544						MCB 512	SH	
VF	500 F2	PC12	84-86			*			MCB 544						MCB 512	SH	
VT	500 C	PC08	83-86						MCB 512	SV					MCS 807		
VT	500 E	PC11	83-85						MCB 526						MCS 807		
XBR	500 S	PC15	85-88						MCB 512	SV					MCS 821		
XL	500 R	PD02	82-						MCS 815						MCS 805		
XL	500 S	PD01	81						MCS 810						MCS 811		
XL	500 S	PD01	79-80						MCS 810						MCS 805		
XR	500 R	PE010	81-82												MCS 805		
XR	500 R	PE03	83-86						MCB 534	SI					MCS 805		
CB	550 F1, F2, K3	CB550K	-78						MCB 35						MCS 809		
CBX	550 F, F2	PC04	82-			*			MCB 526						MCB 543		



* 2 Sätze erforderlich – 2 sets required
Parkbremse – Parkingbrake



ohne Verschleißanzeige – without wear indicator
linke Seite – left side
rechte Seite – right side



Option 1

Option 2

Option 3



Option 1

Option 2

Honda										
CB	600 F Hornet	PC34	98-01	*	MCB 598	SV	SRQ		MCB 634	SH
CB	600 F Hornet	PC36	02-06	*	MCB 598	SV	SRQ		MCB 634	SH
CB	600 F Hornet	PC41	07-	*	MCB 598	SV	SRQ		MCB 784 SH	
CB	600 FA Hornet ABS	PC41	07-	*	MCB 776	SV			MCB 634	SH
CB	600 S Hornet	PC34	98-01	*	MCB 598	SV	SRQ		MCB 634	SH
CB	600 S Hornet	PC36	02-06	*	MCB 598	SV	SRQ		MCB 634	SH
CBF	600 N, S	PC38	04-07	*	MCB 598	SV	SRQ		MCB 634	SH
CBF	600 NA ABS, SA ABS	PC38	04-07	*	MCB 598	SV	SRQ		MCB 634	SH
CBF	600 N, S	PC43	08-	*	MCB 776	SV			MCB 634	SH
CBF	600 NA ABS, SA ABS	PC43	08-	*	MCB 598	SV	SRQ		MCB 634	SH
CBR	600 F	PC19	87-88	*	MCB 562	SV	SRQ		MCB 512	SH
CBR	600 F	PC23	89-90	*	MCB 562	SV	SRQ		MCB 512	SH
CBR	600 F	PC25	91-92	*	MCB 562	SV	SRQ		MCB 634	SH
CBR	600 F	PC25	93-94	*	MCB 562	SV	SRQ		MCB 634	SH
CBR	600 F	PC31	95-98	*	MCB 598	SV	SRQ		MCB 634	SH
CBR	600 F	PC35	99-07	*	MCB 703 SV	SRQ			MCB 634	SH
CBR	600 F	PC41	11-	*	MCB 598	SV	SRQ		MCB 784 SH	
CBR	600 FA ABS	PC41	11-	*	MCB 776	SV			MCB 634	SH
CBR	600 RR	PC37	03-04	*	MCB 703 SV	SRQ	CRQ		MCB 634	SH
CBR	600 RR	PC37	05-06	*	MCB 755 SV	SRQ	CRQ	SCR	MCB 634	SH
CBR	600 RR	PC40	07-08	*	MCB 755 SV	SRQ	CRQ	SCR	MCB 784 SH	
CBR	600 RR	PC40	09-	*	MCB 755 SV	SRQ	CRQ	SCR	MCB 784 SH	
CBR	600 RA ABS	PC40	09-	*	MCB 755 SV	SRQ	CRQ	SCR	MCB 784 SH	
FJS	600 D Silver Wing	PF01	01-09		MCB 704 SRM				MCB 764 SRM	
FJS	600 D Silver Wing	PF01	01-09	P					MCB 832 P	
FJS	600 A Silver Wing ABS	PF01	01-09		MCB 704 SRM				MCB 764 SRM	
FJS	600 A Silver Wing ABS	PF01	01-09	P					MCB 832 P	
SW-T	600 Silver Wing CBS-ABS	PF01	11-		MCB 776 SRM				MCB 764 SRM	
SW-T	600 Silver Wing CBS-ABS	PF01	11-	P					MCB 832 P	
VT	600 C	PC21	88		MCB 571				MCS 806	
VT	600 C	PC21	89-93		MCB 624	SV			MCS 806	
VT	600 C	PC21	94-01		MCB 598	SV			MCS 806	
XL	600 LM	PD04	85-		MCB 512	SV			MCS 805	
XL	600 R	PD03	83-87		MCB 534	SI			MCS 805	
XL	600 RM	PD04	86-		MCB 512	SV			MCS 805	
XL	600 V Transalp	PD06	87-90		MCB 512	SV			MCS 805	
XL	600 V Transalp	PD06	91-93		MCB 624	SV			MCB 585	SH
XL	600 V Transalp	PD06	94-96		MCB 677	SV			MCB 585	SH
XL	600 V Transalp	PD10	97-01	*	MCB 669	SV	EC		MCB 585	SH
XR	600 R	PE04	83-87		MCB 534	SI			MCS 804	
XR	600 R	PE04	88-90		MCB 574	SI	RSI		MCS 804	
XR	600 R	PE04	91-92		MCB 574	SI	RSI		MCB 575	SI EC
XR	600 R	PE04	93-99		MCB 574	SI	RSI		MCB 575	SI EC
CB	650	RC03	79-81	*	MCB 55				MCS 808	
CB	650 C	RC05	80-		MCB 55				MCS 808	
CB	650 F	RC75	14-	*	MCB 677	SV			MCB 841 SH	
CB	650 SC	RC08	83-	*	MCB 512	SV			MCB 543	
CBR	650 F	RC74	14-	*	MCB 677	SV	SRQ		MCB 841 SH	
CBX	650 E	RC13	83-	*	MCB 512	SV			MCS 806	
CX	650 C	RC11	83-	*	MCB 512	SV			MCS 806	
CX	650 E	RC12	83-	*	MCB 544				MCB 512	SH
CX	650 Turbo	RC16	83-	*	MCB 512	SV			MCB 512	SH
FMX	650	RD12	04-		MCB 598	SV			MCB 585	SH
FX	650 Vigor	RD09	99-02		MCB 671	SV			MCB 672	SH
GL	650 D	RC10	83-85	*	MCB 544				MCS 806	
NT	650 V Deauville	RC47	98-01	*	MCB 671	SV			MCB 585	SH
NT	650 V Deauville	RC47	02-05	*	MCB 704	SV			MCB 705	SH
NTV	650 Revere	RC33	88-97		MCB 598	SV			MCB 585	SH
NX	650 Dominator	RD02	88-89		MCB 624	SV			MCB 585	SH
NX	650 Dominator	RD02	90-95		MCB 571	SV			MCB 585	SH
NX	650 Dominator	RD08	96-01		MCB 671	SV			MCB 672	SH EC
SLR	650	RD09	97-98		MCB 671	SV			MCB 672	SH EC
TRX	650 Rincon		03-		MCS 837				MCB 769 SI	
XL	650 V Transalp	RD10	99-01	*	MCB 669	SV			MCB 585	SH
XL	650 V Transalp	RD11	02-07	*	MCB 669	SV			MCB 585	SH



Option 1

Option 2

Option 3



Option 1

Option 2

Honda

XR	650 L	RD06	93-97		MCB 669 SI	RSI	EC		MCB 575 SI	RSI	EC
XR	650 R	RE01	00-07		MCB 669 SI	RSI	EC		MCB 575 SI	RSI	EC
XR	650 Afrika Twin	RD03	88-90		MCB 624	SV			MCB 585	SH	
DN-01	680	RC55	08-	*	MCB 776	SV			MCB 599	SH	
DN-01	680	RC55	08-	P					MCB 832P		
TRX	680 FA6, FGA6 Rincon		06-	*	MCB 823 SI				MCB 769 SI		
TRX	680 Fourtrax		06-	*	MCB 823 SI				MCB 769 SI		
CTX	700 D	RC68	14-		MCB 677	SV			MCB 841	SH	
CTX	700 DA ABS, DCT	RC68	14-		MCB 677	SV			MCB 841	SH	
CTX	700 DA ABS, DCT	RC68	14-	P					MCB 832P		
CTX	700 N	RC68	14-		MCB 677	SV			MCB 841	SH	
CTX	700 NA ABS, ND-DCT	RC68	14-		MCB 677	SV			MCB 841	SH	
CTX	700 NA ABS, ND-DCT	RC68	14-	P					MCB 832P		
NC	700 D Integra ABS, SD-DCT	RC62	12-		MCB 776	SV			MCB 634	SH	
NC	700 D Integra ABS, SD-DCT	RC62	12-	P					MCB 832P		
NC	700 S	RC61	12-		MCB 598	SV			MCB 585	SH	
NC	700 SA ABS, SD-DCT	RC61	12-		MCB 776	SV			MCB 634	SH	
NC	700 SA ABS, SD-DCT	RC61	12-	P					MCB 832 P		
NC	700 X	RC63	12-		MCB 598	SV			MCB 585	SH	
NC	700 XA ABS, XD-DCT	RC63	12-		MCB 776	SV			MCB 634	SH	
NC	700 XA ABS, XD-DCT	RC63	12-	P					MCB 832 P		
NM4	700 Vultus ABS		15-	US market	* MCB 677	SV			MCB 841	SH	
NM4	700 Vultus ABS		15-	US market	P				MCB 832 P		
NT	700 V Deauville	RC52	06-09	*	MCB 776	SV			MCB 705	SH	
NT	700 VA Deauville ABS	RC52	06-09	*	MCB 776	SV			MCB 705	SH	
NT	700 V Deauville	RC59	10-	*	MCB 776	SV			MCB 705	SH	
NT	700 VA Deauville ABS	RC59	10-	*	MCB 776	SV			MCB 705	SH	
TRX	700 Fourtrax		08-		MCB 669 SI				MCB 823 SI		
XL	700 V Transalp	RD13	08-09	*	MCB 669	SV			MCB 585	SH	
XL	700 VA Transalp ABS	RD13	08-09	*	MCB 776	SV			MCB 634	SH	
XL	700 V Transalp	RD15	10-	*	MCB 669	SV			MCB 585	SH	
XL	700 VA Transalp ABS	RD15	10-	*	MCB 776	SV			MCB 634	SH	
CB	750 C	RC06	80-81	*	MCB 55				MCS 808		
CB	750 C	RC06	82-	*	MCB 537				MCS 808		
CB	750 F	CB750F	75-76		MCB 35				MCB 63		
CB	750 F	CB750G	77-78		MCB 54				MCB 63		
CB	750 F1	RC04	80-81	*	MCB 54				MCB 54		
CB	750 F2	RC04	82-	*	MCB 512	SV			MCB 512	SH	
CB	750 K	RC01	82-	*	MCB 512	SV			MCS 808		
CB	750 K1-K6	CB750	71-77		MCB 32				MCS 808		
CB	750 K7	CB750K	78-		MCB 35				MCS 808		
CB	750 KZ	RC01	80-81	*	MCB 55				MCS 808		
CB	750 Seven Fifty	RC42	92-03	*	MCB 598	SV			MCB 634	SH	
CBX	750 F	RC17	84-	*	MCB 512	SV			MCB 512	SH	
NC	750 D Integra ABS, SD-DCT	RC71	14-	*	MCB 677	SV			MCB 634	SH	
NC	750 D Integra ABS, SD-DCT	RC71	14-	P					MCB 832 P		
NC	750 S	RC70	14-	*	MCB 677	SV			MCB 841	SH	
NC	750 SA ABS, SD-DCT	RC70	14-	*	MCB 677	SV			MCB 841	SH	
NC	750 SA ABS, SD-DCT	RC70	14-	P					MCB 832 P		
NC	750 X	RC72	14-	*	MCB 677	SV			MCB 841	SH	
NC	750 XA ABS, XD-DCT	RC72	14-	*	MCB 677	SV			MCB 841	SH	
NC	750 XA ABS, XD-DCT	RC72	14-	P					MCB 832 P		
NM4	750 Vultus ABS		14	*	MCB 677	SV			MCB 841	SH	
NM4	750 Vultus ABS		14	P					MCB 832 P		
NR	750	NC40	92-	*	MCB 593	SV	SRQ		MCB 585	SH	
RVF	750 R	RC45	94-97	*	MCB 593	SV	SRQ		MCB 594		
VF	750 C	RC09	82-92	*	MCB 512	SV			MCS 806		
VF	750 C	RC43	93-99		MCB 598	SV			MCS 822		
VF	750 F	RC15	83-84	*	MCB 512	SV			MCB 512	SH	
VF	750 S	RC07	82-83	*	MCB 512	SV			MCS 806		
VFR	750 F	RC24	86-87	*	MCB 571	SV			MCB 512	SH	
VFR	750 F	RC24	88-89	*	MCB 598	SV	SRQ		MCB 599	SH	
VFR	750 F	RC36	90-97	*	MCB 598	SV	SRQ		MCB 599	SH	



* 2 Sätze erforderlich – 2 sets required
 Parkbremse – Parkingbrake



ohne Verschleißanzeige – without wear indicator
 linke Seite – left side
 rechte Seite – right side



Option 1

Option 2

Option 3



Option 1

Option 2

Honda										
VFR	750 R	RC30	88-89	*	MCB 593 SV	SRQ	CRQ		MCB 594	
VFR	750 R	RC30	90-93	*	MCB 593 SV	SRQ	CRQ		MCB 594	
VT	750 C Shadow	RC29	83-86		MCB 537				MCS 806	
VT	750 C Shadow	RC29	87-		MCB 512	SV			MCS 822	
VT	750 C Shadow	RC44	97-03		MCB 677	SV			MCS 806	
VT	750 C Shadow	RC50	04-09		MCB 677	SV			MCS 806	
VT	750 CS Shadow ABS	RC50	10-		MCB 776	SV			MCB 691	
VT	750 C Shadow Spirit	RC53	07-09		MCB 677	SV			MCS 806	
VT	750 C Shadow Black Spirit	RC53	10-12		MCB 677	SV			MCS 806	
VT	750 C Shadow ABS	RC53	10-		MCB 776	SV			MCB 691	SH
VT	750 D Black Widow	RC48	01-04		MCB 677	SV			MCS 822	
VT	750 S, SA		11-		MCB 677	SV			MCS 806	
XLV	750 R	RD01	84-88		MCB 512	SV			MCS 821	
XRV	750 Afrika Twin	RD04	90-92	*	MCB 562	SV			MCB 585	SH
XRV	750 Afrika Twin	RD07	93-03	*	MCB 669	SV			MCB 585	SH
PC	800 Pacific Coast	RC34	89-98	*	MCB 598	SV			MCS 822	
VFR	800	RC46	98-05	*	MCB 704	SV			MCB 705	SH
VFR	800	RC46	06-09	*	MCB 776	SV			MCB 705	SH
VFR	800 A ABS	RC46	02-05	*	MCB 704	SV			MCB 705	SH
VFR	800 A ABS	RC46	06-	*	MCB 776	SV			MCB 705	SH
VFR	800 XA Crossrunner ABS	RC60	11-14	*	MCB 776 SV				MCB 817 SH	
VFR	800 XA Crossrunner ABS		15-	*	MCB 755 SV				MCB 817SH	
VFR	800 F	RC79	14-	*	MCB 755 SV				MCB 817 SH	
VFR	800 FA ABS	RC79	14-	*	MCB 755 SV				MCB 817 SH	
CB	900 F	SC01	79-81	*	MCB 54				MCB 54	
CB	900 F Hornet	SC48	02-06	*	MCB 593	SV	SRQ		MCB 634	SH
CB	900 F, F2	SC01	81-	*	MCB 512	SV			MCB 512	SH
CB	900 F, F2	SC09	82-	*	MCB 512	SV			MCB 512	SH
CBR	900 RR Fireblade	SC28	92-95	*	MCB 593 SV	SRQ	CRQ		MCB 634	SH
CBR	900 RR Fireblade	SC33	96-97	*	MCB 593 SV	SRQ	CRQ		MCB 634	SH
CBR	900 RR Fireblade	SC33D	98-99	*	MCB 703 SV	SRQ	CRQ		MCB 634	SH
CBR	900 RR Fireblade	SC44	00-01	*	MCB 703 SV	SRQ	CRQ		MCB 634	SH
CBR	954 RR Fireblade	SC50	02-03	*	MCB 703 SV	SRQ	CRQ		MCB 634	SH
CB	1000 R	SC60	08-	*	MCB 755 SV	SRQ			MCB 817 SH	
CB	1000 RA ABS	SC60	08-	*	MCB 776 SV				MCB 817 SH	
CB	1000 Super Four	SC30	93-03	*	MCB 593 SV	SRQ	CRQ		MCB 634	SH
CBF	1000	SC58	06-10	*	MCB 677	SV			MCB 634	SH
CBF	1000 ABS	SC58	06-10	*	MCB 776	SV			MCB 776 SH	
CBF	1000 F	SC64	10-11	*	MCB 677	SV			MCB 634	SH
CBF	1000 FA ABS	SC64	10-	*	MCB 776	SV			MCB 634	SH
CBR	1000 F	SC21	87-88	*	MCB 571	SV			MCB 512	SH
CBR	1000 F	SC24	89	*	MCB 598	SV	SRQ		MCB 599	
CBR	1000 F	SC24	90-92	*	MCB 598	SV	SRQ		MCB 631	SH
CBR	1000 F, Dual CBS	SC24	93-01	*	MCB 658	SV			MCB 658	SV
CBR	1000 RR Fireblade	SC57	04-05	*	MCB 755 SV	SRQ	CRQ	SCR	MCB 634	SH
CBR	1000 RR Fireblade	SC57	06-07	*	MCB 755 SV	SRQ	CRQ	SCR	MCB 784 SH	
CBR	1000 RR Fireblade	SC59	08-11	*	MCB 755 SV	SRQ	CRQ	SCR	MCB 784 SH	
CBR	1000 RA Fireblade ABS	SC59	08-11	*	MCB 755 SV	SRQ	CRQ	SCR	MCB 784 SH	
CBR	1000 RA Fireblade ABS	SC59	12-	*	MCB 755 SV	SRQ	CRQ	SCR	MCB 784 SH	
CBR	1000 RR Fireblade SP	SC59	14-	*	MCB 858 SV	SRQ	CRQ	SCR	MCB 784 SH	
CBX	1000	CB1	79	*	MCB 54				MCB 54	
CBX	1000	SC06	81-	*	MCB 544				MCB 512	SH
GL	1000	GL1, GL2	78	*	MCB 54				MCB 63	
GL	1000	GL1, GL2	75-77	*	MCB 62				MCB 63	
GL	1000	GL1, GL2	81-	*	MCB 54				MCB 54	
VF	1000 F, F2	SC15	84-	*	MCB 512	SV			MCB 512	SH
VF	1000 R	SC16	84-85	*	MCB 512	SV				
VF	1000 R	SC16	86-	*	MCB 512	SV			MCB 512	SH
VTR	1000 Firestorm	SC36	97-08	*	MCB 593 SV	SRQ			MCB 634	SH
VTR	1000 SP1	SC45	00-01	*	MCB 703 SV	SRQ	CRQ		MCB 634	SH
VTR	1000 SP2	SC45	02-07	*	MCB 703 SV	SRQ	CRQ		MCB 634	SH
XL	1000 V Varadero	SD01	99-00	*	MCB 704	SV			MCB 705	SH
XL	1000 V Varadero	SD02	01-03	*	MCB 704	SV			MCB 705	SH
XL	1000 V Varadero	SD02	04-10	*	MCB 776	SV			MCB 705	SH
XL	1000 VA Varadero ABS	SD02	04-10	*	MCB 776	SV			MCB 705	SH



Option 1

Option 2

Option 3



Option 1

Option 2

Honda

XL	1000 VA Varadero ABS	SD03	11-12	*	MCB 776	SV		MCB 705	SH
CB	1100	SC65	13-	*	MCB 703 SV	SRQ		MCB 634	SH
CB	1100 A ABS	SC65	13-	*	MCB 776 SV			MCB 634	SH
CB	1100 EX	SC65	14-	*	MCB 703 SV	SRQ		MCB 634	SH
CB	1100 EX ABS	SC65	14-	*	MCB 776 SV			MCB 634	SH
CB	1100 F	SC11	83-	*	MCB 512	SV		MCB 512	SH
CB	1100 R	SC05	81-	*	MCB 512	SV		MCB 512	SH
CB	1100 R	SC08	82-	*	MCB 512	SV		MCB 512	SH
CB	1100 SF X-Eleven	SC42	00-	*	MCB 704	SV		MCB 705	SH
CBR	1100 XX Blackbird	SC35	98-08	*	MCB 704	SV		MCB 705	SH
GL	1100	SC02	80-81	*	MCB 54			MCB 54	
GL	1100	SC02	82-83	*	MCB 512	SV		MCB 512	SH
ST	1100 Pan European	SC26	90-92	*	MCB 598	SV		MCB 631	SH
ST	1100 Pan European ABS	SC26	92-95	*	MCB 598	SV		MCB 631	SH
ST	1100 Pan European ABS	SC26	96-02	*	MCB 692	SV		MCB 693	
VF	1100 C	SC12	83-	*	MCB 512	SV		MCB 512	SH
VT	1100 C Shadow	SC23	87-93		MCB 512	SV		MCS 822	
VT	1100 C Shadow	SC23	94-98		MCB 598	SV		MCS 822	
VT	1100 C2 Shadow	SC32	95-99		MCB 598	SV		MCB 634	SH
VT	1100 C Shadow	SC39	00-06		MCB 598	SV		MCB 634	SH
GL	1200 D Goldwing	SC14	84-	*	MCB 512	SV		MCB 512	SH
VFR	1200 FA ABS	SC63	10-	*	MCB 828 SV			MCB 817 SH	
VFR	1200 FA ABS	SC63	10-	P				MCB 832P	
VFR	1200 FD ABS DCT	SC63	12-	*	MCB 828 SV			MCB 848 SH	
VFR	1200 FD ABS DCT	SC63	12-	P				MCB 832P	
VFR	1200 XA Crosstourer ABS	SC70	12-	*	MCB 776 SV			MCB 848 SH	
VFR	1200 XA Crosstourer ABS	SC70	12-	P				MCB 832P	
VFR	1200 XD Crosstourer ABS DTC	SC70	12-	*	MCB 776 SV			MCB 848 SH	
VFR	1200 XD Crosstourer ABS DTC	SC70	12-	P				MCB 832P	
CB	1300	SC40	98-00	*	MCB 660 SV	SRQ		MCB 691	SH
CB	1300	SC40	01-02	*	MCB 703 SV	SRQ		MCB 691	SH
CB	1300	SC54	03-04	*	MCB 703 SV	SRQ		MCB 634	SH
CB	1300 S	SC54	05-	*	MCB 703 SV			MCB 634	SH
CB	1300 SA ABS	SC54	05-	*	MCB 776 SV			MCB 634	SH
CB	1300 Superfour	SC54	05-09	*	MCB 703 SV			MCB 634	SH
CB	1300 Superfour ABS	SC54	05-09	*	MCB 703 SV			MCB 634	SH
CB	1300 X-4	SC38	97-	*	MCB 593	SV		MCB 691	SH
CBF	1300 FA ABS		15-	*	MCB 776 SV			MCB 634	SH
CTX	1300 ABS	SC74	14-	*	MCB 776 SV			MCB 599	SH
STX	1300 Pan European	SC51	02-04	*	MCB 704	SV		MCB 705	SH
STX	1300 A Pan European ABS	SC51	02-07	*	MCB 704	SV		MCB 705	SH
STX	1300 A Pan European ABS	SC51	08-	*	MCB 776 SV			MCB 705 SH	
VT	1300 CX	SC61	10-	*	MCB 598	SV		MCB 705	SH
VT	1300 CXA ABS	SC61	10-	*	MCB 776 SV			MCB 705 SH	
VTX	1300 S	SC52	03-08		MCB 598	SV		MCB 634	SH
GL	1500 Goldwing	SC22	88-90	*	MCB 624	SV		MCB 512	SH
GL	1500 SE Goldwing	SC22	91-00	*	MCB 624	SV		MCB 512	SH
GL	1500 F6C Valkyrie	SC34B	97-03	*	MCB 598	SV		MCB 599	SH
GL	1800 Gold Wing	SC47	01-	*	MCB 704	SV		MCB 840 SH	
GL	1800 Gold Wing ABS	SC68	13-	*	MCB 704	SV		MCB 840 SH	
GL	1800 F6B Gold Wing ABS	SC68	13-	*	MCB 704	SV		MCB 840 SH	
VTX	1800 C	SC46	01-08	*	MCB 704	SV		MCB 705	SH

Horex

Rebell	80 N				MCB 508				
Rebell	80 T, Sport 80 L		86-	*	MCB 19			MCB 19	
	560 E		86-	*	MCB 19			MCB 19	
	600 Columbus		87-	*	MCB 19			MCB 19	
VR6	1200		11-	*	MCB 683	SV		MCB 582	

HRD

	50 GS, Enduro		00-		MCB 629			MCB 672	
	50 Sonic 2 Supermot		00-		MCB 629				



* 2 Sätze erforderlich – 2 sets required
 Parkbremse – Parkingbrake



ohne Verschleißanzeige – without wear indicator
 linke Seite – left side
 rechte Seite – right side



Option 1

Option 2

Option 3



Option 1

Option 2

HRD

	50 Sonic 2 Trail	00-		MCB 629					
	125 Supermotard	00-		MCB 629					
	125 Trail	00-		MCB 629					

Husaberg

SM	50	02-		MCB 629				MCB 535	SR
WR	50	02-		MCB 629				MCB 535	SR
TE	125	12-		MCB 648 SI	RSI	EC		MCB 743 SI	RSI EC
FE	250	13-		MCB 648 SI	RSI	EC		MCB 743 SI	RSI EC
TE	250	11-		MCB 648 SI	RSI	EC		MCB 743 SI	RSI EC
TE	300	11-		MCB 648 SI	RSI	EC		MCB 743 SI	RSI EC
	350	94		MCB 648 SI	RSI	EC		MCB 523 SI	
	350	89-93		MCB 574 SI	RSI			MCB 523 SI	
	350	95-		MCB 648 SI	RSI	EC		MCB 672 SI	RSI EC
FE	350	13-		MCB 648 SI	RSI	EC		MCB 743 SI	RSI EC
FE	390	09-		MCB 648 SI	RSI	EC		MCB 743 SI	RSI EC
FE	400 , S,E	FE	98-02	MCB 648 SI	RSI	EC		MCB 672 SI	RSI EC
FC	450		03-08	MCB 648 SI	RSI	EC		MCB 672 SI	RSI EC
FE	450		03-08	MCB 648 SI	RSI	EC		MCB 672 SI	RSI EC
FE	450		09-	MCB 648 SI	RSI	EC		MCB 743 SI	RSI EC
FS	450		03-05	MCB 602 SV	SRQ	CRQ		MCB 672 SI	RSI EC
FS	450		06-14	MCB 793 RSI	SRQ			MCB 672 SI	RSI EC
	500		94	MCB 648 SI	RSI	EC		MCB 523 SI	
	500		89-93	MCB 574 SI	RSI			MCB 523 SI	
	500		95-	MCB 648 SI	RSI	EC		MCB 672 SI	RSI EC
FC	501 , S,E	FE	99-04	MCB 648 SI	RSI	EC		MCB 672 SI	RSI EC
FE	501 , S,E	FE	99-04	MCB 648 SI	RSI	EC		MCB 672 SI	RSI EC
FE	501		13-	MCB 648 SI	RSI	EC		MCB 743 SI	RSI EC
FC	550		04-08	MCB 648 SI	RSI	EC		MCB 672 SI	RSI EC
FE	550		04-08	MCB 648 SI	RSI	EC		MCB 672 SI	RSI EC
FE	570		09-	MCB 648 SI	RSI	EC		MCB 743 SI	RSI EC
FS	570		09-11	MCB 794 RSI	SRQ			MCB 743 SI	RSI EC
FX	570		09-	MCB 648 SI	RSI	EC		MCB 743 SI	RSI EC
	600		89-93	MCB 574 SI	RSI			MCB 523 SI	
	600		94	MCB 648 SI	RSI	EC		MCB 523 SI	
	600		95-	MCB 648 SI	RSI	EC		MCB 672 SI	RSI EC
FC	600 , S,E	FE	93-02	MCB 648 SI	RSI	EC		MCB 672 SI	RSI EC
FE	600 , S,E	FE	93-02	MCB 648 SI	RSI	EC		MCB 672 SI	RSI EC
FE	650 E	FE	01-06	MCB 648 SI	RSI	EC		MCB 672 SI	RSI EC
FS	650 E, C		01-05	MCB 602 SV	SRQ	CRQ		MCB 672 SI	RSI EC
FS	650 E, C		06-	MCB 793 RSI	SRQ			MCB 672 SI	RSI EC
FX	650 E		01-	MCB 648 SI	RSI	EC		MCB 672 SI	RSI EC
FS	450		15-	MCB 792 SV	SRQ	CRQ		MCB 743 SI	RSI EC

Husqvarna

	50 Husky Boy Racing	99-02		MCB 535	SR	EC			
CR	50	10-		MCB 767				MCB 750 SI	RSI
SM	50	10-		MCB 767				MCB 750 SI	RSI
WRS	50	WRS	00-	MCB 535	SR	EC		MCS 962	
CR	65	12-		MCB 740 SI		EC		MCB 831 SI	EC
TC	85	14-		MCB 842 SI				MCB 831 SI	EC
CR	125	84-89		MCB 75	SI				
CR	125	90-91		MCB 579 SI				MCB 523 SI	
CR	125	92-94		MCB 582 SI	RSI			MCB 554 SI	
CR	125	95-		MCB 648 SI	RSI	EC		MCB 672 SI	RSI EC
SM	125 S	09-		MCB 648 SI	RSI	EC		MCB 672 SI	RSI EC
SM	125 Supermotard	99-		MCB 648 SI	RSI	EC		MCB 672 SI	RSI EC
TC	125	14-		MCB 648 SI	RSI	EC		MCB 743 SI	RSI EC
TE	125	11-13		MCB 648 SI	RSI	EC		MCB 672 SI	RSI EC
TE	125	14-		MCB 648 SI	RSI	EC		MCB 743 SI	RSI EC
WR	125	90-91		MCB 579	SI			MCB 523 SI	
WR	125	92-94		MCB 582 SI	RSI			MCB 554 SI	
WR	125	95-		MCB 648 SI	RSI	EC		MCB 672 SI	RSI EC
WRE	125	94-		MCB 648 SI	RSI	EC		MCB 672 SI	RSI EC
WXE	125	07-		MCB 629				MCB 575 SI	RSI EC



Option 1

Option 2

Option 3



Option 1

Option 2

Husqvarna

CR	250		84-89		MCB 75	SI				
CR	250		90-91		MCB 579 SI				MCB 523 SI	
CR	250		92-94		MCB 582 SI	RSI			MCB 554 SI	
CR	250		95-04		MCB 648 SI	RSI	EC		MCB 672 SI	RSI EC
CR	250		05-		MCB 648 SI	RSI	EC		MCB 743 SI	RSI EC
FC	250		14-		MCB 648 SI	RSI	EC		MCB 743 SI	RSI EC
FE	250		14-		MCB 648 SI	RSI	EC		MCB 743 SI	RSI EC
TC	250	H8	02-05		MCB 648 SI	RSI	EC		MCB 672 SI	RSI EC
TC	250		06-		MCB 648 SI	RSI	EC		MCB 743 SI	RSI EC
TE	250	H8	02-05		MCB 648 SI	RSI	EC		MCB 672 SI	RSI EC
TE	250		06-		MCB 648 SI	RSI	EC		MCB 743 SI	RSI EC
WR	250		90-91		MCB 579	SI			MCB 523 SI	
WR	250		92-94		MCB 582 SI	RSI			MCB 554 SI	
WR	250	3H	95-05		MCB 648 SI	RSI	EC		MCB 672 SI	RSI EC
WR	250		06-		MCB 648 SI	RSI	EC		MCB 743 SI	RSI EC
TC	300		14-		MCB 648 SI	RSI	EC		MCB 743 SI	RSI EC
TE	300		14-		MCB 648 SI	RSI	EC		MCB 743 SI	RSI EC
WR	300		06-		MCB 648 SI	RSI	EC		MCB 743 SI	RSI EC
TE	310 4 T		10-		MCB 648 SI	RSI	EC		MCB 743 SI	RSI EC
FC	350		14-		MCB 648 SI	RSI	EC		MCB 743 SI	RSI EC
FE	350		14-		MCB 648 SI	RSI	EC		MCB 743 SI	RSI EC
TE	350		90-92		MCB 579	SI			MCB 523 SI	
TE	350		93-94		MCB 582 SI	RSI			MCB 554 SI	
TE	350		95-		MCB 648 SI	RSI	EC		MCB 672 SI	RSI EC
WR	360	3H	98-		MCB 648 SI	RSI	EC		MCB 672 SI	RSI EC
TE	400	H8	01-		MCB 648 SI	RSI	EC		MCB 672 SI	RSI EC
WR	400		87-88		MCB 579	SI				
TE	410		06-		MCB 648 SI	RSI	EC		MCB 743 SI	RSI EC
TE	410		94-96		MCB 582 SI	RSI			MCB 743 SI	RSI EC
TE	410		97-00		MCB 648 SI	RSI	EC		MCB 672 SI	RSI EC
CR	430		87-88		MCB 579	SI				
WR	430		87-88		MCB 579	SI				
SMR	449		11-	4 ☐	MCB 721 SV	SRQ	CRQ		MCB 743 SI	RSI EC
SM	450 R		03-04		MCB 540	SV	SRQ	CRQ	MCB 672 SI	RSI EC
SM	450 R, RR		06-	Radialc.	4 ☐	MCB 721 SV	SRQ	CRQ	MCB 743 SI	RSI EC
TC	450	H8	02-06		MCB 648	RSI	SI	EC	MCB 672 SI	RSI EC
TC	450		07-		MCB 648	RSI	SI	EC	MCB 743 SI	RSI EC
TE	450	H8	02-06		MCB 648	RSI	SI	EC	MCB 672 SI	RSI EC
TE	450		07-		MCB 648	RSI	SI	EC	MCB 743 SI	RSI EC
FC	450		14-		MCB 648 SI	RSI	EC		MCB 743 SI	RSI EC
FE	450		14-		MCB 648 SI	RSI	EC		MCB 743 SI	RSI EC
TC	500		86-88		MCB 75	SI				
FE	501		14-		MCB 648 SI	RSI	EC		MCB 743 SI	RSI EC
SM	510 R		05	4 ☐	MCB 721 SV	SRQ	CRQ		MCB 672 SI	RSI EC
SM	510 R		06-	4 ☐	MCB 721 SV	SRQ	CRQ		MCB 743 SI	RSI EC
TC	510		88-89		MCB 75	SI				
TC	510		90-91		MCB 579	SI			MCB 667 SI	
TE	510		88-89		MCB 75	SI				
TE	510		90-91		MCB 579	SI			MCB 667 SI	
SMR	511		11-	4 ☐	MCB 721 SV	SRQ	CRQ		MCB 743 SI	RSI EC
TE	511		11-		MCB 648 SI	RSI	EC		MCB 743 SI	RSI EC
TE	570	H8	01-03		MCB 648 SI	RSI	EC		MCB 672 SI	RSI EC
	610 Rallye	H8	95-01		MCB 648	SI	RSI	EC	MCB 672 SI	RSI EC
LT	610 Travelling Adventure		00-		MCB 648	SI	RSI	EC	MCB 672 SI	RSI EC
SM	610 S		00-06		MCB 683 SV	SRQ	CRQ		MCB 672 SI	RSI EC
SM	610 S, IE		07-	Radialc.	4 ☐	MCB 721 SV	SRQ	CRQ	MCB 743 SI	RSI EC
TC	610		91		MCB 579	SI			MCB 523 SI	
TC	610		92-94		MCB 582 SI	RSI			MCB 554 SI	
TC	610		95-		MCB 648	SI	RSI	EC	MCB 672 SI	RSI EC
TE	610		91		MCB 579	SI			MCB 523 SI	
TE	610		92-94		MCB 582 SI	RSI			MCB 554 SI	
TE	610		95-		MCB 648	SI	RSI	EC	MCB 672 SI	RSI EC
SMR	630		06-		MCB 540 SV	SRQ	CRQ		MCB 672 SI	RSI EC



* 2 Sätze erforderlich – 2 sets required
Parkbremse – Parkingbrake



ohne Verschleißanzeige – without wear indicator
linke Seite – left side
rechte Seite – right side



Option 1

Option 2

Option 3



Option 1

Option 2

Husqvarna

STR	650 CRC		07-		4	MCB 721 SV	SRQ	CRQ		MCB 743 SI	RSI	EC
TR	650 Strada	A8	13-			MCB 671	SV			MCB 672	SH	SI
TR	650 Strada ABS	A8	13-			MCB 671	SV			MCB 672	SH	SI
TR	650 Terra	A8	13-			MCB 671	SV			MCB 672	SH	SI
TR	650 Terra ABS	A8	13-			MCB 671	SV			MCB 672	SH	SI
SM	701		15-			MCB 721 SV	SRQ	CRQ		MCB 672 SI	RSI	EC
	900 Nuda ABS		12-		*	MCB 683	SV	SRQ	CRQ	MCB 672	SH	
	900 Nuda R		12-		*	MCB 792 SV	SRQ	CRQ		MCB 672	SH	
	900 Nuda R ABS		12-		*	MCB 792 SV	SRQ	CRQ		MCB 672	SH	

Hyosung

	50 Avanti	SD50	99-01			MCB 519	EC	SR		MCS 993		
	50 Avanti		02-			MCB 519	EC	SR				
	50 Rush		05-07			MCB 519	EC	SR				
	50 Super Cab	SB50	95-			MCB 519	EC	SR		MCS 993		
	50 Super Cab Plus	SB50	98-			MCB 519	EC	SR		MCS 993		
SB	50 Gamma		98-			MCB 519	EC	SR		MCS 993		
SF	50 Racing	SF50	99-			MCB 519	EC	SR		MCS 993		
	100 Super Cab		97-			MCB 519	EC	SR		MCS 993		
SF	100 Rallye		06			MCB 519	EC	SR				
FX	110	FX110M	02-			MCB 519	EC	SR		MCS 993		
	125 Boomer		02-			MCB 75				MCB 525	EC	
	125 Cruise I, II	GA125	95-			MCB 513				MCS 855		
	125 Cruise II Classic	GA125	99-			MCB 513				MCS 855		
	125 Hyper	GPS125	98-			MCB 674	EC	SR		MCS 993		
GA	125 F		00-			MCB 513				MCS 855		
GD	125 EXIV		12-			MCB 703	SV			MCB 519	EC	
GF	125	GF125	98-			MCB 513				MCS 855		
GS	125	GS125	98-			MCB 513				MCS 855		
GT	125 Comet	GT	02-			MCB 822	SV			MCB 822		
GT	125 Naked	GT	02-			MCB 822	SV			MCB 822		
GT	125 R Supersport		04-			MCB 822	SV			MCB 822		
GV	125 Aquila	GV125	00-			MCB 822	SV			MCS 855		
RT	125 Karion		02-06			MCB 822	SV			MCS 962		
RT	125 Karion		07-			MCB 822	SV			MCB 822		
XRX	125	RX125	99-06			MCB 822	SV					
XRX	125 SM		07-			MCB 822	SV			MCB 822		
GD	250 EXIV		15-			MCB 703	SV			MCB 710	EC	
GT	250 Comet		04-05			MCB 822	SV			MCB 822		
GT	250 Naked		06-			MCB 822	SV			MCB 822		
GT	250 i Naked/R		15-		*	MCB 703	SV			MCB 710	EC	
GV	250 Aquila	GV250	04-07			MCB 822	SV			MCS 855		
GV	250 i Classic		08-			MCB 822	SV			MCS 855		
MS	250 3i		07-			MCB 582 SRM				MCB 582 SRM		
MS	250 3i					MCB 615 SRM						
TE	400		05-06		*	MCB 510 SI						
TE	450		06-		*	MCB 510 SI				MCB 626 SI		
GT	650 Comet Naked		03-08		*	MCB 822	SV			MCB 822		
GT	650 i Naked	GT650	09-		*	MCB 703	SV			MCB 822		
GT	650 i R Sport	GT650	09-		*	MCB 703	SV			MCB 822		
GT	650 i R		15-		*	MCB 703	SV			MCB 710	EC	
GT	650 X, S, R		03-08		*	MCB 822	SV			MCB 822		
GV	650 Aquila		04-05		*	MCB 822	SV			MCB 731		
GV	650 Aquila i		06-10		*	MCB 822	SV			MCB 822		
GV	650 i Sportcruiser		11-		*	MCB 703	SV			MCB 822		
GV	700 C Efi		11-			MCB 822	SV			MCB 822		
ST	700 i		11-			MCB 703	SV			MCB 822		
GV	700 C		06-09			MCB 822	SV			MCB 822		

Indian

	1130 Scout		15-			MCB 876 SV				MCB 877 SH		
	1700 Chief Blackhawk		10-		*	MCB 540	SV			MCB 19	SH	
	1700 Chief Bomber		10-		*	MCB 540	SV			MCB 19	SH	
	1700 Chief Classic		10-		*	MCB 540	SV			MCB 19	SH	
	1700 Chief Dark Horse		10-		*	MCB 540	SV			MCB 19	SH	
	1700 Chief Deluxe		09-		*	MCB 540	SV			MCB 19	SH	



Option 1

Option 2

Option 3



Option 1

Option 2

Indian

1700 Chief Roadmaster		09-		*	MCB 540	SV			MCB 19	SH	
1700 Chief Standard		09-		*	MCB 540	SV			MCB 19	SH	
1700 Chief Vintage		09-		*	MCB 540	SV			MCB 19	SH	
1800 Chief Classic		09-		*	MCB 595	SV			MCB 599	SH	
1800 Chief Vintage		09-		*	MCB 595	SV			MCB 599	SH	
1800 Chieftrain		09-		*	MCB 595	SV			MCB 599	SH	
1800 Chieftrain Roadmaster ABS		15-		*	MCB 737 SV				MCB 599	SH	

Italjet

50 Dragster	DRG	98-			MCB 535	EC	SR		MCB 535	EC	SR
50 Formula	FR 50	94-96			MCB 651	EC			MCB 696	EC	SR
50 Formula Air	FRH1BS	99-			MCB 535	EC	SR		MCS 921		
50 Formula L.C.	FRH	98-			MCB 535	EC	SR		MCB 535	EC	SR
50 Jet-Set	TP	02-			MCB 735	EC			MCS 994		
50 Torpedo, 4T	TP	99-			MCB 535	EC	SR		MCS 921		
50 Velocifero		98-02			MCS 831				MCS 921		
50 .it		09-			MCB 615	EC					
50 Pit Jet		07-09			MCB 844				MCB 844		
50 Rollercraft		08-			MCB 822	SV			MCB 663	EC	
100 Millenium 2T	FC	01-			MCB 519	EC	SR		MCS 968		
125 Amarcord		08-			MCB 665	EC					
125 Dragster	DR5010	00-03			MCB 535	EC	SR		MCB 535	EC	SR
125 Dragster	DR5010	97-99			MCB 535	EC	SR		MCS 994		
125 Formula		94-96			MCB 651	EC			MCB 696	EC	SR
125 Formula		97-			MCB 535	EC	SR		MCB 535	EC	SR
125 Jack		07-			MCB 746	SRM			MCB 746	SRM	
125 Jet-Set	JK	02-			MCB 735	EC			MCS 994		
125 Jupiter	JC	02-			MCB 666	SRM			MCB 699	SRM	
125 Millenium	FC	00-			MCB 519	EC	SR		MCS 968		
125 Pit Jet		07-			MCB 844				MCB 844		
125 Torpedo	TP	99-			MCB 535	EC	SR		MCS 994		
125 Torpedo		07-			MCB 822				MCB 663		
150 Jupiter	JC	02-			MCB 666	SRM			MCB 699	SRM	
150 Torpedo		08-			MCB 822				MCB 663	SRM	EC
180 Dragster	DR5810	98-			MCB 535	EC	SR		MCB 535	EC	SR
250 Jupiter	JC	02-			MCB 666	SRM			MCB 796		
250 Dragster		07-			MCB 535	EC	SR		MCB 535	EC	SR
650 Bazooka		06-			MCB 822	SV			MCB 822		
650 Grifon		06-			MCB 822	SV			MCB 822		
900 Grifon		00-			MCB 540	SV					

Jack Fox (Benzhou)

YY	50 QT				MCB 590	EC			MCS 800		
	50 City Star				MCB 590	EC			MCS 800		
	50 Retro Star				MCB 590	EC			MCS 800		
	50 Formula				MCB 590	EC			MCS 800		

Jawa

	50 Mosquito		97-		MCB 674	EC	SR				
D	50		94-		MCB 676						
	125 Butterfly		98-		MCB 676						
	250 Enduro 593		93-		MCB 676						
	280 City Enduro				MCB 676						
	280 Enduro Sport				MCB 676						
	350 Chopper 639-2		93-		MCB 676						
	350 Sport		93-		MCB 676						
	350 Style		93-		MCB 676						
TS	350 /3.30				MCB 676						
	593 City Enduro				MCB 676						
	593 Enduro Sport				MCB 676						
	640 Sport		93-		MCB 676						
	640 Style		93-		MCB 676						



* 2 Sätze erforderlich – 2 sets required
Parkbremse – Parkingbrake



ohne Verschleißanzeige – without wear indicator



linke Seite – left side



rechte Seite – right side



Option 1

Option 2

Option 3



Option 1

Option 2

JohnDeere

HPX	350 Gator	10-	NO SHIMS!	*	MCB 860 SI				MCB 860 SI		
-----	-----------	-----	-----------	---	------------	--	--	--	------------	--	--

Jonway (Benzhou)

YY	50 QT	07-			MCB 822				MCB 822		
YY	80 QT	07-			MCB 822				MCB 822		
YY	125	07-			MCB 615	SRM	EC		MCB 615	SRM	EC
YY	150	07-			MCB 615	SRM	EC		MCB 615	SRM	EC
YY	150 T	08-			MCB 822				MCB 822		
YY	250	07-			MCB 615	SRM	EC		MCB 615	SRM	EC
YY	250 T	08-			MCB 822				MCB 822		

Kawara

	50 Fever	90-99			MCB 590	EC					
	50 Stinger	90-99			MCB 590	EC					
	90 Fever	90-99			MCB 590	EC					
	90 Stinger	90-99			MCB 590	EC					

Kawasaki

AE	50	AE050A	81-85		MCS 854				MCS 854		
AR	50	AR050A	81-		MCB 519	EC	SR		MCS 854		
KDX	50		03-05		MCS 840				MCS 840		
KFX	50 KSF	LM4AA	03-05		MCS 838				MCS 901		
KFX	50 KSF	WA04A	07-						MCB 712		
KX	60		83-99		MCS 857				MCS 857		
KX	65		00-		MCB 714 SI	EC			MCB 561 SI	EC	
AE	80	AE080A	81-85		MCS 854				MCS 854		
AR	80	AR080A	81-		MCB 519	EC	SR		MCS 854		
KFX	80		03-06		MCS 838						
KMX	80		87-		MCB 522						
KX	80		84-87		MCB 519 SI	EC			MCS 857		
KX	80		88-96		MCB 519 SI	EC			MCB 561 SI	EC	
KX	80		97-00		MCB 697 SI	RSI	EC		MCB 561 SI	EC	
KX	85		01-		MCB 697 SI	RSI	EC		MCB 561 SI	EC	
KFX	90 KSF	WE07A	07-						MCB 712		
KE	100		82-01		MCS 854				MCS 854		
KH	100 EL		77-81		MCS 855				MCS 854		
KH	100 G		83		MCB 523				MCS 854		
KH	100 G		84-89		MCB 523				MCS 855		
KM	100		79-81		MCS 854				MCS 854		
KV	100 A, B		77-89		MCS 854				MCS 854		
KX	100		89-96		MCB 519 SI	EC			MCB 561 SI	EC	
KX	100		97-09		MCB 697 SI	RSI	EC		MCB 561 SI	EC	
KLX	110		02-		MCS 857				MCS 857		
KDX	125		90-		MCB 519	EC			MCB 625 SI		
KE	125 A	K1033,K1048	76-82						MCS 855		
KH	125	KH125	77-80		MCB 91						
KH	125	KH125	81		MCB 510				MCS 855		
KH	125	KH125	82-		MCB 523	SI			MCS 855		
KLX	125 CAF		10-		MCB 582	SI	RSI		MCB 510	SI	
KLX	125 D-Tracker		10-		MCB 582	SI	RSI		MCB 510	SI	
KLX	125 A		03-06		MCS 901				MCS 901		
KLX	125 B		03-06		MCB 679	SI	EC		MCS 901		
KMX	125	MX125A	86		MCB 519	SI	EC		MCB 523 SI		
KMX	125	MX125A	87-89		MCB 522				MCB 523 SI		
KMX	125	MX125B	96-98		MCB 522				MCB 523 SI		
KMX	125	MX125B	99-02		MCB 679	SI	EC		MCB 523 SI		
KX	125		74-80						MCS 855		
KX	125		81-82		MCB 519 SI	EC			MCS 855		
KX	125		83-85		MCB 523 SI				MCS 854		
KX	125		86		MCB 523 SI				MCB 523 SI		
KX	125		87-88		MCB 573				MCB 523 SI		
KX	125		89-93		MCB 582 SI	RSI			MCB 625 SI	RSI	
KX	125		94		MCB 574 SI	RSI			MCB 625 SI	RSI	
KX	125		95-		MCB 574 SI	RSI			MCB 575 SI	RSI	EC
ZL	125 Eliminator	BN125A	97-99		MCB 510				MCS 855		
ZL	125 Eliminator	BN125A	00-		MCB 615	SV	EC		MCS 855		



Option 1

Option 2

Option 3



Option 1

Option 2

Kawasaki

KLX	140		08-		MCB 582	SI	RSI		MCB 561SI	EC	
KDX	175	DX175B	81-						MCS 855		
KE	175	KE175D	79-						MCS 861		
KDX	200		86-88		MCB 523 SI				MCS 854		
KDX	200		89-92		MCB 523 SI				MCB 625 SI		
KDX	200		93-94		MCB 582 SI	RSI			MCB 625 SI		
KDX	200		95-01		MCB 669 SI	RSI	EC		MCB 575 SI	RSI	EC
KLF	200		88-97		MCS 839						
KLT	200		81-84		MCS 854				MCS 839		
KMX	200	MX200	88-90		MCB 519	SI	EC		MCB 523 SI		
Z	200	KZ200A	77-82		MCB 91				MCS 855		
Z	200		83-		MCB 523				MCS 855		
KLF	220 Bayou		88-01		MCS 839				MCS 853		
	250 Estrella	BJ250A	92-		MCB 523				MCB 523		
EL	250 Eliminator	EL250B	88-90		MCB 532				MCS 853		
EL	250 Eliminator	EL250E	91-96		MCB 532				MCS 853		
GPX	250		88-06		MCB 569				MCB 586		
GPZ	250	EX250C	83-84		* MCB 523				MCS 853		
GPZ	250	EX250D	85-		* MCB 523				MCB 532		
KDX	250		79-84		MCS 839				MCS 855		
KH	250	KH250B	76-78		MCB 79						
KL	250		78-79		MCS 839				MCS 902		
KL	250	KL250A	80-82						MCS 861		
KL	250		83-84		MCB 593						
KL	250 H SUPER SHERPA	KL250H	99-05		MCB 697 SI				MCB 523		
KL	250	KL250J	00-12		MCB 697 SI				MCB 523		
KLF	250 Bayou		03-11		MCS 839				MCS 853		
KLR	250	KL250D	85-96		MCB 523	SI			MCS 861		
KLT	250 Prairie		83-85		MCS 854				MCS 839		
KLX	250	LX250B	-92						MCS 855		
KLX	250 R		06-08		MCB 669	SI	RSI	EC	MCB 665		
KLX	250 R	LX250E	93-05		MCB 669	SI	RSI	EC	MCB 625 SI		
KLX	250 S	LX250S	09-		MCB 582	SI	RSI		MCB 575 SI	RSI	EC
KR-1	250	KR250A	88		MCB 586	SV			MCB 586		
KR-1	250	KR250B2	89		* MCB 586	SV			MCB 586		
KR-1S	250	KR250C2	90-		* MCB 602	SV	SRQ	CRQ	MCB 586		
KX	250		74-81		MCS 839				MCS 902		
KX	250		81-82		MCB 519 SI				MCS 855		
KX	250		83-85		MCB 523 SI				MCS 855		
KX	250		86		MCB 523 SI				MCB 523 SI		
KX	250		87-88		MCB 573				MCB 523 SI		
KX	250		89-93		MCB 582 SI	RSI			MCB 625 SI	RSI	
KX	250		94		MCB 669 SI	RSI	EC		MCB 625 SI	RSI	
KX	250		95-04		MCB 669 SI	RSI	EC		MCB 575 SI	RSI	EC
KX	250 F	KXF250	04-		MCB 669 SI	RSI	EC		MCB 739 SI	RSI	EC
SC	250 Epsilon		02-	☐	MCB 706 SRM	EC			MCB 746 SRM		
Z	250 A1, A2	KZ250A	79-81		MCB 79				MCB 531		
Z	250 A3	KZ250A	81		MCB 516				MCB 531		
Z	250 B1, B2	KZ250B	80-83						MCS 853		
Z	250 C1, C2, G1, G2	KZ250C/G	81-83						MCS 855		
ZZR	250		90-04		MCB 569				MCB 523		
	250 Ninja R	EX250K	08-12		MCB 615	SV	EC		MCB 615	SH	EC
EL	252	EL250F	97-00		MCB 532				MCS 853		
EL	252	EL250F	01-		MCB 582				MCS 853		
	300 Ninja R	EX300A	13-		MCB 615	SV	EC		MCB 615	SH	EC
	300 Ninja R ABS	EX300A	13-		MCB 615	SV	EC		MCB 615	SH	EC
KAF	300 Mule 500				MCS 841						
KAF	300 Mule 550				MCS 841						
KEF	300 B		95-		* MCB 560 SI				MCB 561 SI		
KLF	300 Bayou		88		* MCB 523 SI				MCS 853		
KLF	300 Bayou		89-	☐	MCB 582 SI	SV			MCS 892		
KLF	300 Bayou		89-	☐	MCB 615 SI	SV					
KLX	300 R	LX300B	97-		MCB 669	SI	RSI	EC	MCB 575 SI	RSI	EC



* 2 Sätze erforderlich – 2 sets required
Parkbremse – Parkingbrake



ohne Verschleißanzeige – without wear indicator



linke Seite – left side



rechte Seite – right side



Option 1

Option 2

Option 3



Option 1

Option 2

Kawasaki

KVF	300 A, B, 4WD		99-04						MCB 510 SI					MCS 892		
KVF	300 Brute Force		13-					*	MCB 510 SI					MCB 760 SI		
J	300	C4	14-						MCB 598 SRM					MCB 830 SRM		
Z	300 ABS		15-						MCB 615	SV	EC			MCB 615	SH	EC
GPZ	305	EX305B	84-89					*	MCB 523					MCS 853		
KVF	360		03-11						MCB 510 SI							
GPX	400 R	ZX400F	87-					*	MCB 586	SV				MCB 569	SH	
GPZ	400 R	KZ400J	83-84					*	MCB 515					MCB 516		
GPZ	400 R	ZX400A	85-88					*	MCB 523					MCB 532		
GPZ	400 R		89-					*	MCB 586	SV				MCB 569	SH	
KFX	400	KFX400	03-04					*	MCB 554 SI					MCB 626 SI		
KFX	400	AK47B	05-					*	MCB 554 SI					MCB 626 SI		
KH	400	S3F	76-81						MCB 79							
KLF	400 Bayou		93-99					☑	MCB 582 SI					MCS 892		
KLF	400 Bayou		93-99					☑	MCB 615 SI							
KLX	400		03-						MCB 669	SI	RSI	EC		MCB 575 SI	RSI	EC
KSF	400	KFX 400	03-					*	MCB 554 SI					MCB 626 SI		
KVF	400 Prairie	VF400A	97-98					*	MCB 510 SI					MCS 892		
KVF	400 Prairie 2x4	VF400D	98-01					*	MCB 510 SI					MCS 892		
KVF	400 Prairie 4x4	VF400C	98-01					*	MCB 510 SI					MCS 892		
Z	400 B1/B2	K4B	78-80						MCB 506					MCS 853		
Z	400 F	ZR400A/B	83-84						MCB 523					MCS 853		
Z	400 F2	ZR400C	85-87						MCB 523					MCS 853		
Z	400 G	K4G	79						MCB 79					MCS 852		
Z	400 J1	KZ400J	80						MCB 79					MCS 852		
Z	400 J2/J3	KZ400J	81-83					*	MCB 515					MCS 852		
ZR	400 D	ZR400D	92-95						MCB 586					MCB 519		
ZR	400 G	ZR400G	96-01					*	MCB 602	SV				MCB 662	SH	
ZRX	400	ZR400E	94-95						MCB 569	SV				MCB 662	SH	
ZRX	400	ZR400E	96-97					☑	MCB 682	SV				MCB 662	SH	
ZRX	400	ZR400E	96-97					☑	MCB 681	SV						
ZRX	400	ZR400E	98-01													
ZXR	400	ZX400L	91-03					*	MCB 643	SRQ				MCB 531	SH	
ZXR	400 R	ZX400R	89-94					*	MCB 602	SV	SRQ	CRQ		MCB 531	SH	
	400 Ninja R		11-					☑	MCB 682	SV				MCB 662	SH	
	400 Ninja R		11-					☑	MCB 681	SV						
KX	420		80-81						MCS 839					MCS 902		
Z	440	KZ440C	80-81						MCB 79					MCS 853		
Z	440	KZ440H	82-83						MCB 516					MCS 853		
Z	440 LTD	KZ440A	80-81						MCB 79					MCS 853		
Z	440 LTD	KZ440D	82-						MCB 516					MCS 853		
KFX	450	SF450B	07-					☑	MCB 758 SI	RSI						
KFX	450	SF450B	07-					☑	MCB 757 SI	RSI				MCB 561SI		
KLX	450 R	LX450	07-12						MCB 669 SI	RSI	EC			MCB 739 SI	RSI	EC
KX	450 F	KX450	04-08						MCB 669 SI	RSI	EC			MCB 739 SI	RSI	EC
KX	450 F		09-						MCB 669 SI	RSI	EC			MCB 739 SI	RSI	EC
Z	450 LTD	EN450A	84-89						MCB 532					MCS 852		
EN	500	EN500A	90-91						MCB 532					MCS 853		
EN	500	EN500B	92-96						MCB 532					MCS 852		
EN	500	EN500C	97-94						MCB 532					MCS 852		
ER-5	500 Twister	ER500A/B	97-00						MCB 569	SV				MCS 853		
ER-5	500 Twister	ER500C/D	01-						MCB 682	SV				MCS 853		
GPZ	500 S	EX500A	87-93			US, AU market			MCB 569	SV				MCS 853		
GPZ	500 S	EX500B	88-93					*	MCB 523					MCS 853		
GPZ	500 S	EX500D	94-01						MCB 586	SV				MCB 523		
GPZ	500 S	EX500E	95-04					*	MCB 586	SV				MCB 523		
KH	500	H1F	76-79						MCB 79							
KLE	500	LE500A	91-07						MCB 569	SV				MCB 523		
KX	500		83-85						MCB 523 SI					MCS 855		
KX	500		86						MCB 523 SI					MCB 523 SI		
KX	500		87-88						MCB 573					MCB 523 SI		
KX	500		89-93						MCB 582 SI	RSI				MCB 625 SI	RSI	
KX	500		94-95						MCB 669 SI	RSI	EC			MCB 625 SI	RSI	
KX	500		96-04						MCB 669 SI	RSI	EC			MCB 575 SI	RSI	EC
Z	500	KZ500B	79-80					*	MCB 79					MCB 73		



Option 1

Option 2

Option 3



Option 1

Option 2

Kawasaki

Z	500	KZ500B	81-83			MCB 515					MCB 516		
ZZR	500	ZX500C	90-92	AT market	*	MCB 602	SV				MCB 569	SH	
ZZR	500	ZX500D	93-94	AT market	*	MCB 602	SV				MCB 662	SH	
GPZ	550	ZX550A	84-89		*	MCB 532					MCB 532		
GT	550	KZ550G	83-90		*	MCB 523					MCS 852		
Z	550	KZ550B	81-82		*	MCB 515					MCB 516		
Z	550 F	KZ550B	83-84		*	MCB 523					MCS 853		
Z	550 F	KZ550B	85-		*	MCB 532					MCS 852		
Z	550 GP	KZ550D	81		*	MCB 515					MCB 516		
Z	550 GP	KZ550H	82-83		*	MCB 515					MCB 516		
Z	550 LTD	KZ550C	80-82			MCB 515					MCS 852		
ZR	550	KZ550A	83-90		*	MCB 523					MCS 853		
ZR	550 Zephyr	ZR550B	91-92		*	MCB 569	SV				MCB 586		
ZR	550 Zephyr	ZR550B	93-95		*	MCB 586	SV				MCB 662	SH	
ZR	550 Zephyr	ZR550B	96-99		*	MCB 569	SV				MCB 662	SH	
GPX	600 R	ZX600C	88-99		*	MCB 569	SV				MCB 569	SH	
GPZ	600 R	ZX600A	85-89		*	MCB 532					MCB 532		
KLR	600	KL600A	84			MCB 523	SI				MCS 855		
KLR	600	KL600B	85-89			MCB 523	SI				MCS 855		
ZL	600 Eliminator	ZL600A	86-94			MCB 532					MCS 852		
ZL	600 Eliminator	ZL600B	95-97			MCB 569	SV				MCS 853		
ZX-6R	600 Ninja	ZX600F	94-97		*	MCB 602 SV	SRQ	CRQ			MCB 662	SH	
ZX-6R	600 Ninja	ZX600G	98-99		*	MCB 659 SV	SRQ	CRQ			MCB 662	SH	
ZX-6R	600 Ninja	ZX600J	00-02		*	MCB 659 SV	SRQ	CRQ			MCB 662	SH	
ZX-6R	600 Ninja	ZX600P	07-08		4☐ *	MCB 789 SV	SRQ	CRQ	SCR		MCB 662	SH	
ZX-6R	600 Ninja	ZX600R	09-		4☐ *	MCB 789 SV	SRQ	CRQ	SCR		MCB 662	SH	
ZX-6RR	600 Ninja	ZX600K	03-04		4☐ *	MCB 742 SV	SRQ	CRQ	SCR		MCB 662	SH	
ZX-6RR	600 Ninja	ZX600N	05-06		4☐ *	MCB 742 SV	SRQ	CRQ	SCR		MCB 662	SH	
ZZR	600	ZX600D	90-92		*	MCB 602	SV	SRQ	CRQ		MCB 569	SH	
ZZR	600	ZX600E	93-05		*	MCB 602	SV	SRQ	CRQ		MCB 662	SH	
ZX-6R	636 Ninja	ZX636A	02		*	MCB 659 SV	SRQ	CRQ			MCB 662	SH	
ZX-6R	636 Ninja	ZX636B	03-04		4☐ *	MCB 742 SV	SRQ	CRQ	SCR		MCB 662	SH	
ZX-6R	636 Ninja	ZX636C	05-06		4☐ *	MCB 742 SV	SRQ	CRQ	SCR		MCB 662	SH	
ZX-6R	636 Ninja	ZX636E	13-		*	MCB 850 SV	SRQ	CRQ			MCB 784 SH		
ZX-6R	636 Ninja ABS	ZX636E	13-		*	MCB 850 SV	SRQ	CRQ			MCB 784 SH		
ER-6	650 F	EX650A	06-08		☐	MCB 682	SV	SRQ					
ER-6	650 F	EX650A	06-08		☐	MCB 681	SV	SRQ			MCB 662	SH	
ER-6	650 F ABS	EX650A	06-08		☐	MCB 682	SV	SRQ					
ER-6	650 F ABS	EX650A	06-08		☐	MCB 681	SV	SRQ			MCB 662	SH	
ER-6	650 F	EX650C	09-11		☐	MCB 682	SV	SRQ					
ER-6	650 F	EX650C	09-11		☐	MCB 681	SV	SRQ			MCB 662	SH	
ER-6	650 F ABS	EX650C	09-11		☐	MCB 682	SV	SRQ					
ER-6	650 F ABS	EX650C	09-11		☐	MCB 681	SV	SRQ			MCB 662	SH	
ER-6	650 F	EX650E	12-		☐	MCB 682	SV	SRQ					
ER-6	650 F	EX650E	12-		☐	MCB 681	SV	SRQ			MCB 662	SH	
ER-6	650 F ABS	EX650E	12-		☐	MCB 682	SV	SRQ					
ER-6	650 F ABS	EX650E	12-		☐	MCB 681	SV	SRQ			MCB 662	SH	
ER-6	650 N	ER650A	06-08		☐	MCB 682	SV	SRQ					
ER-6	650 N	ER650A	06-08		☐	MCB 681	SV	SRQ			MCB 662	SH	
ER-6	650 N ABS	ER650A	06-08		☐	MCB 682	SV	SRQ					
ER-6	650 N ABS	ER650A	06-08		☐	MCB 681	SV	SRQ			MCB 662	SH	
ER-6	650 N	ER650C	09-11		☐	MCB 682	SV	SRQ					
ER-6	650 N	ER650C	09-11		☐	MCB 681	SV	SRQ			MCB 662	SH	
ER-6	650 N ABS	ER650C	09-11		☐	MCB 682	SV	SRQ					
ER-6	650 N ABS	ER650C	09-11		☐	MCB 681	SV	SRQ			MCB 662	SH	
ER-6	650 N	ER650E	12-		☐	MCB 682	SV	SRQ					
ER-6	650 N	ER650E	12-		☐	MCB 681	SV	SRQ			MCB 662	SH	
ER-6	650 N ABS	ER650E	12-		☐	MCB 682	SV	SRQ					
ER-6	650 N ABS	ER650E	12-		☐	MCB 681	SV	SRQ			MCB 662	SH	
KLE	650 Versys	LE650A	07-09		☐	MCB 682	SV	SRQ			MCB 662	SH	
KLE	650 Versys	LE650A	07-09		☐	MCB 681	SV	SRQ					
KLE	650 Versys ABS	LE650A	07-09		☐	MCB 682	SV	SRQ			MCB 662	SH	
KLE	650 Versys ABS	LE650A	07-09		☐	MCB 681	SV	SRQ					



* 2 Sätze erforderlich – 2 sets required
 Parkbremse – Parkingbrake



ohne Verschleißanzeige – without wear indicator



linke Seite – left side



rechte Seite – right side



Option 1

Option 2

Option 3



Option 1

Option 2

Kawasaki

KLE	650 Versys	LE650C	10-14		☑	MCB 682	SV	SRQ		MCB 662	SH	
KLE	650 Versys	LE650C	10-14		☑	MCB 681	SV	SRQ				
KLE	650 Versys ABS	LE650C	10-14		☑	MCB 682	SV	SRQ		MCB 662	SH	
KLE	650 Versys ABS	LE650C	10-14		☑	MCB 681	SV	SRQ				
KLE	650 Versys ABS, Versys LT ABS		15-		*	MCB 598	SV			MCB 841	SH	
KLR	650	KL650A	87-88			MCB 573				MCB 523		
KLR	650	KL650B	89-94			MCB 569	SV			MCB 523		
KLR	650	KL650C	95-04			MCB 682	SV			MCB 523		
KLX	650	KLX650A/B/C	93-03			MCB 669	SI	RSI	EC	MCB 625 SI		
KVF	650 Brute Force 4x4i		05-		☑	MCB 582 SI						
KVF	650 Brute Force 4x4i		05-		☑	MCB 615 SI						
KVF	650 Prairie	KV650	01-03		☑	MCB 757 SI						
KVF	650 Prairie		01-03		☑	MCB 758 SI						
W	650	EJ650A	99-05			MCB 681	SV			MCS 853		
Z	650	KZ650F	80-83		*	MCB 515				MCS 852		
Z	650	KZ650D	79-81	☑ 16"	*	MCB 79				MCB 73		
Z	650 Mags	KZ650C	78-79		*	MCB 79						
Z	650	KZ650F	77-79	spoke wheel	*	MCB 79				MCS 852		
	650 Vulcan S		15-			MCB 704				MCB 634	SH	
KFX	700 KSV	SV700A	04-		☑	MCB 757 SI						
KFX	700 KSV	SV700A	04-		☑	MCB 758 SI						
KSV	700 V-Force	SV700A	04-		☑	MCB 757 SI						
KSV	700 V-Force	SV700A	04-		☑	MCB 758 SI						
KVF	700 Prairie	KVF700	04-06		☑	MCB 757 SI						
KVF	700 Prairie	KVF700	04-06		☑	MCB 758 SI						
GPX	750 R	ZX750F	87-		*	MCB 569	SV			MCB 569	SH	
GPZ	750 R	ZX750G	85-86		*	MCB 532				MCB 532		
GPZ	750 Turbo	ZX750E	84-85			MCB 532				MCB 532		
GPZ	750 UT (Uni-Trak)	ZX750A	83-85		*	MCB 532				MCB 532		
GT	750	KZ750P	82-		*	MCB 515				MCB 516		
KRF	750		08-		☑	MCB 582 SI						
KRF	750		08-		☑	MCB 615 SI						
KVF	750 Brute Force	KVF750	05-		☑	MCB 615 SI						
KVF	750 Brute Force	KVF750	05-		☑	MCB 582 SI						
VN	750	VN750A	86-95			MCB 532				MCS 852		
Z	750	ZR750J	04-06		☑	MCB 682	SV	SRQ				
Z	750	ZR750J	04-06		☑	MCB 681	SV	SRQ		MCB 662	SH	
Z	750 S	ZR750J	05-06		☑	MCB 682	SV	SRQ				
Z	750 S	ZR750J	05-06		☑	MCB 681	SV	SRQ		MCB 662	SH	
Z	750	ZR750L	07-11		*	MCB 598	SV	SRQ		MCB 634	SH	
Z	750 ABS	ZR750L	07-11		*	MCB 598	SV	SRQ		MCB 634	SH	
Z	750 R	ZR750N	11-12		4☑ *	MCB 789 SV				MCB 841	SH	
Z	750 R ABS	ZR750N	11-12		4☑ *	MCB 789 SV				MCB 841	SH	
Z	750 B	KZ750B	76-79			MCB 79						
Z	750 E	KZ750E	80-81		*	MCB 515				MCB 516		
Z	750 GP Uni-Trak	ZX750A	83-84		*	MCB 532				MCB 532		
Z	750 GP R	KZ750R	82		*	MCB 515				MCB 532		
Z	750 L	KZ750E	81-82		*	MCB 515				MCB 516		
Z	750 L	KZ750R	83-		*	MCB 515				MCB 516		
Z	750 LTD	KZ750H	80-82		*	MCB 79				MCS 852		
Z	750 LTD	KZ750Y	82-		*	MCB 515				MCS 852		
Z	750 LTD	KZ750K	83-		*	MCB 516				MCS 852		
ZR	750 Zephyr	ZR750C	91-95		*	MCB 569	SV			MCB 569	SH	
ZR	750 Zephyr	ZR750D	96-99		☑	MCB 682	SV					
ZR	750 Zephyr	ZR750D	96-99		☑	MCB 681	SV			MCB 569	SH	
ZR-7	750	ZR750F	99-04		☑	MCB 682	SV	SRQ				
ZR-7	750	ZR750F	99-04		☑	MCB 681	SV	SRQ		MCB 681	SH	
ZR-7	750 S	ZR750F	01-03		☑	MCB 682	SV	SRQ				
ZR-7	750 S	ZR750F	01-03		☑	MCB 681	SV	SRQ		MCB 681	SH	
ZX	750 A1, E, GP	ZX750E	84-85		*	MCB 532				MCB 532		
ZX-7R	750 Ninja	ZX750P	96-02		*	MCB 659 SV	SRQ	CRQ		MCB 531	SH	
ZX-7RR	750 Ninja	ZX750N	96-99		*	MCB 660 SV	SRQ	CRQ		MCB 691	SH	
ZXR	750	ZX750H	89-90		*	MCB 602	SV	SRQ	CRQ	MCB 531	SH	
ZXR	750	ZX750J	91-95		*	MCB 602	SV	SRQ	CRQ	MCB 531	SH	
ZXR	750	ZX750L	91-95		*	MCB 602	SV	SRQ	CRQ	MCB 531	SH	



Option 1

Option 2

Option 3



Option 1

Option 2

Kawasaki

ZXR	750 R	ZX750K	91-92		*	MCB 602	SV	SRQ	CRQ	MCB 531	SH
ZXR	750 R	ZX750M	93-95		*	MCB 602	SV	SRQ	CRQ	MCB 531	SH
ZXR	750 RR	ZX750N	96-99		*	MCB 660 SV	SRQ	CRQ		MCB 691	SH
KRF	800 Teryx		14-		☑	MCB 582 SI					
KRF	800 Teryx		14-		☑	MCB 615 SI					
VN	800	VN800A/B	95-99			MCB 532				MCS 852	
VN	800 Classic	VN800B	96-06			MCB 682	SV			MCS 852	
VN	800 Drifter	VN800C	99-05			MCB 682	SV			MCB 681	SH
W	800	EJ800A	11-			MCB 681	SV			MCS 853	
Z	800	ZR800A	13-		*	MCB 737 SV				MCB 841 SH	
Z	800 ABS	ZR800A	13-		*	MCB 737 SV				MCB 841 SH	
Z	800 e Version	ZR800C	13-		*	MCB 737 SV				MCB 841 SH	
Z	800 e Version ABS	ZR800C	13-		*	MCB 737 SV				MCB 841 SH	
Z	800 ABS		15-		*	MCB 598	SV			MCB 841	SH
Z	800 e Version ABS		15-		*	MCB 598	SV			MCB 841	SH
GPZ	900 R	ZX900A	84-89		*	MCB 532				MCB 532	
GPZ	900 R	ZX900A	90-94		*	MCB 602	SV	SRQ	CRQ	MCB 569	SH
VN	900 Classic, LT, SE	VN900B	06-			MCB 682	SV			MCB 843	SH
VN	900 Custom	VN900C	07-			MCB 682	SV			MCB 843	SH
Z	900	Z1F	76-77		*	MCB 79				MCS 851	
Z1	900	Z1F	73-75			MCB 16					
ZX-9R	900 Ninja	ZX900B	94-95		*	MCB 602	SV	SRQ	CRQ	MCB 662	SH
ZX-9R	900 Ninja	ZX900B	96-97		*	MCB 659	SV	SRQ	CRQ	MCB 662	SH
ZX-9R	900 Ninja	ZX900C	98-99		*	MCB 659	SV	SRQ	CRQ	MCB 662	SH
ZX-9R	900 Ninja	ZX900E	00-01		*	MCB 659	SV	SRQ	CRQ	MCB 662	SH
ZX-9R	900 Ninja	ZX900E	02-04		*	MCB 737 SV	SRQ	CRQ		MCB 662	SH
GPZ	1000 RX	ZXT00A	86-87		*	MCB 532				MCB 532	
GTR	1000	ZGT00A	86-93		*	MCB 532				MCB 532	
GTR	1000	ZGT00A	94-01		*	MCB 569	SV			MCB 532	
KLZ	1000 Versys ABS	LZT00A	12-14		*	MCB 602	SV			MCB 634	SH
KLZ	1000 Versys ABS		15-		*	MCB 602	SV			MCB 634	SH
KLV	1000	LV1000A	04-		☑	MCB 682	SV				
KLV	1000	LV1000A	04-		☑	MCB 681	SV			MCB 634	SH
Z	1000	ZRT00A	03-06		*	MCB 737 SV	SRQ			MCB 662	SH
Z	1000	ZRT00B	07-08		4 ☑	MCB 789 SV				MCB 634	SH
Z	1000 ABS	ZRT00B	07-09		4 ☑	MCB 789 SV				MCB 634	SH
Z	1000	ZRT00D	10-		*	MCB 752 SV				MCB 662	SH
Z	1000 ABS	ZRT00D	10-		*	MCB 752 SV				MCB 662	SH
Z	1000 SX	ZXT00G	11-12		*	MCB 752 SV				MCB 662	SH
Z	1000 SX ABS	ZXT00G	11-12		*	MCB 752 SV				MCB 662	SH
Z	1000 SX	ZXT00L	13-		*	MCB 752 SV				MCB 662	SH
Z	1000 SX ABS	ZXT00L	13-		*	MCB 752 SV				MCB 662	SH
Z	1000 K	KZCK1BA	81		*	MCB 516				MCB 516	
Z	1000 LTD	KZT00J	81-82		*	MCB 516				MCB 516	
Z	1000 MK2	KZT00A	78-80		*	MCB 79				MCB 73	
Z	1000 R	KZT00R	83-		*	MCB 532				MCB 532	
Z	1000 ST	KZT00E	79-81		*	MCB 505				MCB 73	
Z	1000	KZT00A	77-79		*	MCB 79				MCB 73	
Z	1000	KZT00H	80-		*	MCB 79				MCB 73	
Z	1000 Z1R	KZT00D	78-80		*	MCB 79				MCB 73	
ZL	1000	ZLT00A	87-88		*	MCB 532				MCB 532	
ZX-10R	1000 Ninja	ZXT00B	88-90		*	MCB 569	SV			MCB 569	SH
ZX-10R	1000 Ninja	ZXT00C/D	04-07		4 ☑	MCB 742 SV	SRQ	CRQ	SCR	MCB 662	SH
ZX-10R	1000 Ninja	ZXT00E	08-09		*	MCB 752 SV	SRQ	CRQ	SCR	MCB 662	SH
ZX-10R	1000 Ninja	ZXT00F	10		*	MCB 752 SV	SRQ	CRQ	SCR	MCB 784 SH	
ZX-10R	1000 Ninja ABS	ZXT00F	10		*	MCB 752 SV	SRQ	CRQ	SCR	MCB 784 SH	
ZX-10R	1000 Ninja	ZXT00J	11-14		*	MCB 752 SV	SRQ	CRQ	SCR	MCB 784 SH	
ZX-10R	1000 Ninja ABS	ZXT00J	11-		*	MCB 752 SV	SRQ	CRQ	SCR	MCB 784 SH	
ZX-10R	1000 Ninja ABS		15-		*	MCB 752 SV	SRQ	CRQ	SCR	MCB 784 SH	
	1000 Ninja H2 ABS		15-		*	MCB 792 SV	SRQ	CRQ	SCR	MCB 700 SH	
	1000 Ninja H2R ABS		15-		*	MCB 792 SV	SRQ	CRQ	SCR	MCB 700 SH	
GPZ	1100	ZXT10A	83-85		*	MCB 532				MCB 532	
GPZ	1100	ZXT10E	95-97		☑	MCB 682	SV			MCB 662	SH



* 2 Sätze erforderlich – 2 sets required
 Parkbremse – Parkingbrake



ohne Verschleißanzeige – without wear indicator



linke Seite – left side



rechte Seite – right side



Option 1

Option 2

Option 3



Option 1

Option 2

Kawasaki

GPZ	1100	ZXT10E	95-97		☑	MCB 681	SV					
GPZ	1100	ZXT10E	97-98		☑	MCB 682	SV			MCB 662	SH	
GPZ	1100	ZXT10E	97-98		☑	MCB 681	SV					
Z	1100 GP	KZT10B	81-82		*	MCB 516				MCB 516		
Z	1100 ST	KZT10A	81-83		*	MCB 515				MCB 516		
ZR	1100 Zephyr	ZRT10B	97		☑	MCB 682	SV			MCB 532		
ZR	1100 Zephyr	ZRT10B	97		☑	MCB 681	SV					
ZR	1100 Zephyr	ZRT10A/B	91-96		*	MCB 602	SV			MCB 569	SH	
ZRX	1100	ZRT10C	96-00		*	MCB 659	SV	SRQ	CRQ	MCB 531	SH	
ZX-11	1100		93-97		*	MCB 602	SV	SRQ	CRQ	MCB 569	SH	
ZZR	1100	ZXT10C	90-92		*	MCB 602	SV	SRQ	CRQ	MCB 569	SH	
ZZR	1100	ZXT10D	93-97		*	MCB 602	SV	SRQ	CRQ	MCB 531	SH	
ZZR	1100	ZXT10G	98-01		*	MCB 602	SV	SRQ	CRQ	MCB 531	SH	
ZRX	1200 R	ZRT20A/B	01-06		*	MCB 659	SV	SRQ	CRQ	MCB 531	SH	
ZRX	1200 S	ZRT20A/B	01-04		*	MCB 659	SV	SRQ	CRQ	MCB 531	SH	
ZX-12R	1200 Ninja	ZXT20A	00-03		*	MCB 659 SV	SRQ	CRQ		MCB 531	SH	
ZX-12R	1200 Ninja	ZXT20B	04-06	4☐	*	MCB 742 SV	SRQ	CRQ	SCR	MCB 531	SH	
ZZR	1200	ZXT20C	02-05		*	MCB 602	SV	SRQ	CRQ	MCB 531	SH	
Z	1300	KZT30A	79-83		*	MCB 505				MCB 73		
Z	1300 DFI	ZGT30A	84-89		*	MCB 505				MCB 73		
ZG	1300	ZGT30A	84-89		*	MCB 505				MCB 73		
ZN	1300	KZT30AG	83-85		*	MCB 532				MCB 532		
GTR	1400 ABS	ZGT40A	07-09	4☐	*	MCB 789 SV				MCB 691 SH		
GTR	1400 ABS	ZGT40C	10-	4☐	*	MCB 789 SV				MCB 691 SH		
ZZR	1400 ABS	ZXT40A	06-07	4☐	*	MCB 789 SV				MCB 691 SH		
ZZR	1400 ABS	ZXT40C	08-11	4☐	*	MCB 789 SV				MCB 691 SH		
ZZR	1400 ABS	ZXT40E	12-	4☐	*	MCB 789 SV				MCB 691 SH		
VN	1500 Classic	VNT50D	96-99			MCB 682	SV			MCB 532		
VN	1500 Classic Fi	VNT50N	00-04			MCB 682	SV			MCB 681	SH	
VN	1500 Classic Tourer Fi	VNT50G	98-03		☑	MCB 682	SV					
VN	1500 Classic Tourer Fi	VNT50G	98-03		☑	MCB 681	SV			MCB 843	SH	
VN	1500 Drifter	VNT50J	99-04			MCB 682	SV			MCB 681	SH	
VN	1500 Mean Streak	VNT50P	02-04			MCB 659	SV			MCB 843	SH	
VN	1500 NOMAD, NOMAD Fi	VNT50G/L	98-03		☑	MCB 681	SV			MCB 843	SH	
VN	1500 NOMAD, NOMAD Fi	VNT50G/L	98-93		☑	MCB 682	SV					
VN	1500 SE	VNT50B	88-93			MCB 532				MCB 532		
VN	1500 SE	VNT50C	94-95			MCB 532				MCB 532		
VN	1500 Sumo	VNT50A	88-93			MCB 532				MCB 532		
VN	1600 Classic	VNT60A	03-08		☑	MCB 682	SV					
VN	1600 Classic	VNT60A	03-08		☑	MCB 681	SV			MCB 843	SH	
VN	1600 Classic Tourer	VNT60A	05-08		☑	MCB 682	SV					
VN	1600 Classic Tourer	VNT60A	05-08		☑	MCB 681	SV			MCB 843	SH	
VN	1600 Mean Streak	VNT60B	04		*	MCB 659	SV			MCB 843	SH	
VN	1600 Mean Streak	VNT60B	05-08	4☐	*	MCB 742 SV				MCB 843	SH	
VN	1700 Classic ABS	VNT70E	09-		☑	MCB 682	SV			MCB 843	SH	
VN	1700 Classic ABS	VNT70E	09-		☑	MCB 681	SV					
VN	1700 Classic Tourer ABS	VNT70C	09-		☑	MCB 682	SV			MCB 843	SH	
VN	1700 Classic Tourer ABS	VNT70C	09-		☑	MCB 681	SV					
VN	1700 Voyager ABS	VNT70A	09-		*	MCB 602	SV			MCB 843	SH	
VN	1700 Voyager Custom ABS	VNT70A	11-		*	MCB 602	SV			MCB 843	SH	
VN	2000	VNW00A	04-08		*	MCB 602	SV			MCB 843	SH	
VN	2000 Classic	VNW00H	08-10		*	MCB 602	SV			MCB 843	SH	

Keeway

RY-6	50		10-			MCB 694	EC			MCS 962		
RY-8	50 SP, Sport Evo		07-			MCB 694	EC			MCS 962		
	50 Agora		10-			MCB 525	EC			MCS 962		
	50 Arn		10-11			MCB 674	EC	SR				
	50 F-Act		07-			MCB 694	EC			MCS 962		
	50 Flash		07-09			MCB 519	EC	SR		MCS 962		
	Flash Electric		09-10	Electric		MCB 694	EC			MCS 962		
	50 F-NKD Racing		07-			MCB 694	EC			MCS 962		
	50 Focus		06-07			MCB 694	EC			MCS 962		
	50 Goccia		08-			MCB 674	EC	SR				
	50 Hurricane		06-09			MCB 519	EC	SR		MCS 962		



Option 1

Option 2

Option 3



Option 1

Option 2

Keeway

	50 Matrix V2,V3, V4		06-					MCB 694	EC							MCS 962		
	90 Hurricane		06-					MCB 519	EC	SR								
	100 Partner		06-					MCB 663	EC	SRM								
	110 Partner		06-					MCB 663	EC	SRM								
K2	125		07					MCB 744	EC	SRM						MCB 744	EC	SRM
	125 Arn		06-					MCB 674	EC	SR						MCS 953		
	125 F-Act		07-11					MCB 694	EC							MCS 962		
	125 Focus		06-07					MCB 694	EC							MCS 953		
	125 Hacker		08-					MCB 674	EC	SR						MCB 75		
	125 Matrix		07-10					MCB 694	EC							MCS 953		
	125 Outlook, Sport		07-					MCB 582		SRM						MCB 582		SRM
	125 Silverblade		10-					MCB 663		SRM	EC					MCB 663		SRM
	125 Speed		06-					MCB 765								MCB 663	EC	SRM
	125 Superlight		07-					MCB 582										
K2	150		07					MCB 744	EC	SRM						MCB 744	EC	SRM
	150 Arn		06-					MCB 674	EC	SR								
	150 Focus		06-					MCB 694	EC									
	150 Matrix		06-10					MCB 694	EC									
	150 Speed		06-					MCB 765										
K2	250		07					MCB 744	EC	SRM						MCB 744	EC	SRM
	250 Dragon Quad		07-09				*	MCB 519 SI								MCB 510 SI		

Kram-it

GS	250		97-					MCB 648 SI	RSI	EC						MCB 672 SI	RSI	EC
MX	250		97-					MCB 648 SI	RSI	EC						MCB 672 SI	RSI	EC
SM	250		97-					MCB 648 SI	RSI	EC						MCB 672 SI	RSI	EC
SMR	250		97-					MCB 648 SI	RSI	EC						MCB 672 SI	RSI	EC
ER	alle Modelle							MCB 579	SI							MCB 523		

Kreidler

XL	25 Florett	SAF-1	99-					MCB 522										
	50	MF2/MF4						MCS 828								MCS 828		
	50	MP1						MCS 828								MCS 828		
	50 Florett		81-82					MCB 513										
	50 Florett	SAF	99-					MCB 519	EC	SR								
	50 Flory	MF20/22						MCS 828								MCS 828		
	50 Florett D, RMC		07-					MCB 615	EC									
	50 Florett RS 50 DD Sport		07-					MCB 844										
	50 Flory Classic							MCB 519	EC	SR								
	50 Flory RC							MCB 590	EC									
	50 Galactica 2.0 50 DD							MCB 844										
	50 Galactica 2.0 Electro							MCB 615	EC									
	50 Hiker 2.0 50 DD Sport							MCB 844										
	50 Jigger							MCB 844										
	125 Mustang		83-					MCB 536								MCB 75		
	125 Enduro		07-					MCB 689	EC									
	125 Supermoto		07-					MCB 689	EC							MCB 510		SI
	170 Mustang		06-					MCS 962								MCB 582 SI		
	200 Enduro		07-					MCB 689	EC									

KTM

	50 Chrono							MCB 696	EC	SR						MCS 800		
	50 GO Edition	KTMGO50	12/94-					MCB 578								MCS 800		
	50 GXE							MCB 553										
	50 Kross	KTMGO50	95-					MCB 696	EC	SR						MCS 800		
	50 MLS, RLW, RSL							MCB 75		SI								
	50 PL, RS, RL							MCB 75		SI								
ARK	50 AC/LC		97-					MCB 696	EC	SR						MCB 696	EC	SR
ARK	50 K		97-					MCB 696	EC	SR						MCS 800		
SX	50 Mini Adventure		04-06					MCS 828								MCS 828		
SX	50 Pro Mini Senior Adventure		04-06					MCB 750 RSI								MCS 828		
SX	50 Pro Senior		02-03					MCB 750 RSI								MCS 828		
SX	50 Pro Senior LC 12"		04-					MCB 750 RSI								MCB 750 RSI		
SX	60		98-00					MCB 535	EC							MCB 552		



* 2 Sätze erforderlich – 2 sets required
Parkbremse – Parkingbrake



ohne Verschleißanzeige – without wear indicator
linke Seite – left side
rechte Seite – right side



Option 1

Option 2

Option 3



Option 1

Option 2

KTM

SX	65		00-01		MCB 535	EC			MCB 552		
SX	65		02-03		MCB 740 SI	EC			MCB 552		
SX	65		04-08		MCB 740 SI	EC			MCB 750 SI	RSI	
SX	65		09-		MCB 740 SI	EC			MCB 740 SI	EC	
SX	85	SX85	04-10		MCB 740 SI	EC			MCB 740 SI	EC	
SX	85		11		MCB 740 SI	EC			MCB 831 SI	EC	
SX	85		12-		MCB 842 SI				MCB 831 SI	EC	
	125 Duke		11-		MCB 834				MCB 672 SI	RSI	EC
	125 Duke ABS		11-		MCB 834				MCB 672 SI	RSI	EC
	125 GS		90-91		MCB 648	RSI	SI	EC	MCB 557		
	125 GS		92-93		MCB 648	RSI	SI	EC	MCB 523 SI		
	125 GS		94-97		MCB 648	RSI	SI	EC	MCB 672 SI	RSI	EC
MX	125 Enduro		86		MCB 75	SI			MCB 75	SI	
MX	125 Enduro		87		MCB 572				MCB 572		
MX	125 Enduro		88		MCB 592				MCB 523 SI		
MX	125 Enduro		89-91		MCB 523 SI				MCB 523 SI		
MX	125 Enduro		92-93		MCB 648	SI	RSI	EC	MCB 523 SI		
MX	125 Enduro		94		MCB 648	SI	RSI	EC	MCB 672 SI	RSI	EC
MX	125 Sting	KTM 125	97-99		MCB 540	SV			MCB 672	SH	EC
EXC	125 Enduro	KTM-2T-EXC	90-91		MCB 648	RSI	SI	EC	MCB 557		
EXC	125 Enduro	KTM-2T-EXC	92-93		MCB 648	RSI	SI	EC	MCB 523 SI		
EXC	125 Enduro	KTM-2T-EXC	94-03		MCB 648	SI	RSI	EC	MCB 672 SI	RSI	EC
EXC	125 Enduro	KTM-2T-EXC	04-		MCB 648	SI	RSI	EC	MCB 743 SI	RSI	EC
EXE	125 Super Enduro	KTM-2T-EXE	00		MCB 648	SI	RSI	EC	MCB 672 SI	RSI	EC
EXE	125 Supermoto		00		MCB 648	SI	RSI	EC	MCB 672 SI	RSI	EC
RC	125		14-		MCB 834				MCB 672	SI	EC
SX	125	VBKMXH	96-03		MCB 648 SI	RSI	EC		MCB 672 SI	RSI	EC
SX	125		04-		MCB 648 SI	RSI	EC		MCB 743 SI	RSI	EC
SX	150		07-		MCB 648 SI	RSI	EC		MCB 743 SI	RSI	EC
XC	150		07-		MCB 648 SI	RSI	EC		MCB 743 SI	RSI	EC
EXC	200 Enduro	KTM-2T-EXC	99-03		MCB 648	SI	RSI	EC	MCB 672 SI	RSI	EC
EXC	200 Enduro	KTM-2T-EXC	04-		MCB 648	SI	RSI	EC	MCB 743 SI	RSI	EC
XC-W	200		04-		MCB 648 SI	RSI	EC		MCB 743 SI	RSI	EC
RC	200		14-		MCB 834				MCB 672	SI	EC
SX	200	VBKMXK	03-04		MCB 648 SI	RSI	EC		MCB 743 SI	RSI	EC
	200 Duke		12-		MCB 834				MCB 672 SI	RSI	EC
	200 Duke ABS		12-		MCB 834				MCB 672 SI	RSI	EC
MX	250 Enduro		86		MCB 75	SI			MCB 75	SI	
MX	250 Enduro		87		MCB 572				MCB 572		
MX	250 Enduro		88		MCB 592				MCB 523 SI		
MX	250 Enduro		89-91		MCB 523 SI				MCB 523 SI		
MX	250 Enduro		92-93		MCB 648	SI	RSI	EC	MCB 523 SI		
MX	250 Enduro		94		MCB 648	SI	RSI	EC	MCB 672 SI	RSI	EC
EXC	250 Enduro	KTM-4T-EXC	04-		MCB 648	SI	RSI	EC	MCB 743 SI	RSI	EC
EXC	250 Enduro		04-		MCB 648	SI	RSI	EC	MCB 743 SI	RSI	EC
EXC	250 Enduro	KTM-2T-EXC	99-03		MCB 648	SI	RSI	EC	MCB 672 SI	RSI	EC
EXC	250 Enduro	KTM-4T-EXC	99-03		MCB 648	SI	RSI	EC	MCB 672 SI	RSI	EC
EXC	250 Enduro	KTM-2T-EXC	04-		MCB 648	SI	RSI	EC	MCB 743 SI	RSI	EC
EXC-F	250	KTM-2T-EXC	07-		MCB 648	SI	RSI	EC	MCB 743 SI	RSI	EC
SX	250	VBKMXN	03-		MCB 648 SI	RSI	EC		MCB 743 SI	RSI	EC
SX	250	VBKMXN	96-02		MCB 648 SI	RSI	EC		MCB 672 SI	RSI	EC
SX-F	250	SXF250	06-		MCB 648 SI	RSI	EC		MCB 743 SI	RSI	EC
XC-	250		04-		MCB 648	SI	RSI	EC	MCB 743 SI	RSI	EC
XC-W	250		04-		MCB 648	SI	RSI	EC	MCB 743 SI	RSI	EC
E-SM	Freeride		15-	Electric	MCB 842 SI				MCB 831 SI		
E-SX	Freeride		15-	Electric	MCB 842 SI				MCB 831 SI		
E-XC	Freeride		15-	Electric	MCB 842 SI				MCB 831 SI		
	250 Freeride R		14-		MCB 842 SI				MCB 831 SI		
EXC	300 Enduro	KTM-2T-EXC	04-		MCB 648	SI	RSI	EC	MCB 743 SI	RSI	EC
EXC	300 Enduro	KTM-2T-EXC	99-03		MCB 648	SI	RSI	EC	MCB 672 SI	RSI	EC
MX	350 Enduro		86		MCB 75	SI			MCB 75	SI	
MX	350 Enduro		87		MCB 572				MCB 572		
MX	350 Enduro		88		MCB 592				MCB 523 SI		
MX	350 Enduro		89-91		MCB 523 SI				MCB 523 SI		
MX	350 Enduro		92-93		MCB 648	SI	RSI	EC	MCB 523 SI		



Option 1

Option 2

Option 3



Option 1

Option 2

KTM

MX	350 Enduro		94		MCB 648	SI	RSI	EC	MCB 672 SI	RSI	EC
EXC	350 Enduro		94-97		MCB 648	SI	RSI	EC	MCB 672 SI	RSI	EC
EXC-F	350		11-		MCB 648 SI	RSI	EC		MCB 743 SI	RSI	EC
SX-F	350	SXF350	11-		MCB 648 SI	RSI	EC		MCB 743 SI	RSI	EC
	350 Freeride		12-		MCB 842 SI				MCB 831 SI		
EXC	380 Enduro		98-03		MCB 648	SI	RSI	EC	MCB 672 SI	RSI	EC
SX	380		96-		MCB 648 SI	RSI	EC		MCB 672 SI	RSI	EC
RC	390		14-		MCB 834				MCB 672	SI	EC
	390 Duke ABS		13-		MCB 834				MCB 672 SI	RSI	EC
EXC	400 Racing	KTM-4T-EXC	04-07		MCB 648	SI	RSI	EC	MCB 743 SI	RSI	EC
EXC	400 Racing	KTM-4T-EXC	00-03		MCB 648	SI	RSI	EC	MCB 672 SI	RSI	EC
LC4	400 Enduro		92-93		MCB 648	SI	RSI	EC	MCB 523 SI		
LC4	400 Enduro		94-		MCB 648	SI	RSI	EC	MCB 672 SI	RSI	EC
LC4-E	400 Enduro	KTM-4T-EGS	99-01		MCB 648	SI	RSI	EC	MCB 672 SI	RSI	EC
SC	400 Super Competition	4T-SC	96-99		MCB 648	SI	RSI	EC	MCB 672 SI	RSI	EC
SXC	400 Racing	KTM-4T-EGS	00-02		MCB 648 SI	RSI	EC		MCB 672 SI	RSI	EC
	450 Rally		11-		MCB 671	SV			MCB 672 SI	RSI	EC
	450 SMR		05-06		MCB 793 RSI	SRQ			MCB 743 SI	RSI	EC
	450 SMR		07-13	4 ☐	MCB 794 RSI	SRQ			MCB 743 SI	RSI	EC
	450 SMR		14-	4 ☐	MCB 792 SV	SRQ	CRQ		MCB 743 SI	RSI	EC
	450 Super Moto Werksreplika		04	4 ☐	MCB 540	SRQ	CRQ		MCB 743 SI	RSI	EC
EXC	450 Racing	KTM-4T-EXC	03		MCB 648	SI	RSI	EC	MCB 672 SI	RSI	EC
EXC	450 Racing	KTM-4T-EXC	04-		MCB 648	SI	RSI	EC	MCB 743 SI	RSI	EC
EXC-F	450		08-		MCB 648 SI	RSI	EC		MCB 743 SI	RSI	EC
SX	450	VBKMXN	03-06		MCB 648 SI	RSI	EC		MCB 743 SI	RSI	EC
SX-F	450 ATV		08-09		MCB 824 SI				MCB 825 SI		
SX-F	450 Racing	SXF450	07-		MCB 648 SI	RSI	EC		MCB 743 SI	RSI	EC
XC	450 ATV		08-10		MCB 824 SI				MCB 825 SI		
	450 Rally		11-		MCB 648 SI	RSI	EC		MCB 672 SI	RSI	EC
MX	500 Enduro		86		MCB 75	SI			MCB 75	SI	
MX	500 Enduro		87		MCB 572				MCB 572		
MX	500 Enduro		88		MCB 592				MCB 523 SI		
MX	500 Enduro		89-91		MCB 523	SI			MCB 523 SI		
MX	500 Enduro		92-93		MCB 648	SI	RSI	EC	MCB 523 SI		
MX	500 Enduro		94-95		MCB 648	SI	RSI	EC	MCB 672 SI	RSI	EC
EXC	505		09-		MCB 648 SI	RSI	EC		MCB 743 SI	RSI	EC
SX	505 ATV		08-		MCB 824 SI				MCB 825 SI		
SX-F	505 Racing		07-09		MCB 648 SI	RSI	EC		MCB 743 SI	RSI	EC
XC	505 ATV		08-		MCB 824 SI				MCB 825 SI		
EXC	520 Racing	KTM-4T-EXC	00-02		MCB 648	SI	RSI	EC	MCB 672 SI	RSI	EC
SX	520 Racing	VBKMXM	00-02		MCB 648 SI	RSI	EC		MCB 672 SI	RSI	EC
EXC	525 Racing	KTM-4T-EXC	03		MCB 648	SI	RSI	EC	MCB 672 SI	RSI	EC
EXC	525 Racing	KTM-4T-EXC	04-06		MCB 648	SI	RSI	EC	MCB 743 SI	RSI	EC
SX	525 Racing	VBKMXM	03		MCB 648 SI	RSI	EC		MCB 672 SI	RSI	EC
SX	525 Racing		04-06		MCB 648 SI	RSI	EC		MCB 743 SI	RSI	EC
SX	525 SMR		05		MCB 793 RSI	SRQ			MCB 743 SI	RSI	EC
XC	525 ATV		08-		MCB 824 SI				MCB 825 SI		
XC	525 Racing		06-07		MCB 648 SI	RSI	EC		MCB 743 SI	RSI	EC
EXC	530		08-11		MCB 648	SI	RSI	EC	MCB 743 SI	RSI	EC
SXC	540	KTM-4T-EGS	99-00		MCB 648 SI	RSI	EC		MCB 672 SI	RSI	EC
	560 SMR		06		MCB 793 RSI	SRQ			MCB 743 SI	RSI	EC
	560 SMR		07	4 ☐	MCB 794 RSI	SRQ			MCB 743 SI	RSI	EC
LC4	600 Enduro		88-91		MCB 592				MCB 592		
LC4	600 Enduro		92-93		MCB 648	SI	RSI	EC	MCB 523 SI		
LC4	600 Enduro		94-		MCB 648	SI	RSI	EC	MCB 672 SI	RSI	EC
LC4	620 Adventure		97-01		MCB 648	SI	RSI	EC	MCB 672	SI	EC
LC4	620 Competition	KTM-4T-EGS	99-		MCB 648	SI	RSI	EC	MCB 672 SI	RSI	EC
LC4	620 Competition Supermoto	KTM-4T-EGS	00-		MCB 648	SI	RSI	EC	MCB 672 SI	RSI	EC
LC4	620 Duke		94-98		MCB 540	SV	CRQ		MCB 672 SI	RSI	EC
LC4	620 Enduro		95-99		MCB 648	SI	RSI	EC	MCB 672 SI	RSI	EC
SC	620 Super Competition	4T-SC	96-01		MCB 648	SI	RSI	EC	MCB 672 SI	RSI	EC
SC	620 Supermoto	4T-SC	98-01		MCB 648	SI	RSI	EC	MCB 672 SI	RSI	EC
	625 SMC		05-06		MCB 683	SV	SRQ	CRQ	MCB 672	SI	EC



* 2 Sätze erforderlich – 2 sets required
Parkbremse – Parkingbrake



ohne Verschleißanzeige – without wear indicator
linke Seite – left side
rechte Seite – right side



Option 1

Option 2

Option 3



Option 1

Option 2

KTM

LC4	625 Super Competition		02		MCB 648	SI	RSI	EC	MCB 672 SI	RSI	EC
LC4	625 Supermoto		02		MCB 648	RSI	SI	EC	MCB 672 SI	RSI	EC
SXC	625		03-06		MCB 648	SI	RSI	EC	MCB 672 SI	RSI	EC
LC4	640 Adventure	KTM-4T-EGS	00-07		MCB 648	SV	SI	EC	MCB 672 SH	SI	EC
LC4	640 Duke I		98		MCB 540	SV	CRQ	SRQ	MCB 672 SH	SI	EC
LC4	640 Duke II	KTMDKII	99-07		MCB 683	SV	CRQ	SRQ	MCB 672 SH	SI	EC
LC4	640 Enduro	KTM-4T-EGS	99-04		MCB 648	SV	SI	EC	MCB 672 SH	SI	EC
LC4	640 Supermoto	KTM-4T-EGS	99-02		MCB 648	RSI	SI	EC	MCB 672 SI	RSI	EC
LC4	640 Supermoto		03		MCB 540	SV	SRQ	CRQ	MCB 672	RSI	EC
LC4	640 Supermoto		04-06		MCB 683	SV	SRQ	CRQ	MCB 672	RSI	EC
LC4	660 SMC Supermoto	4T-SC	03-04		MCB 540	SV	SRQ	CRQ	MCB 672	RSI	EC
LC4	660 SMC Supermoto	4T-SC	05-06		MCB 683	SV	SRQ	CRQ	MCB 672	RSI	EC
LC4	690 Enduro, Enduro R		08-		MCB 671	SV			MCB 672 SH	SI	EC
LC4	690 SMC		07-11		MCB 683 SV	SRQ	CRQ		MCB 672	RSI	EC
LC4	690 Duke		08-11	4☐	MCB 721 SV	SRQ			MCB 672 SH	SI	EC
LC4	690 Duke R		10-11	4☐	MCB 721 SV	SRQ			MCB 672 SH	SI	EC
LC4	690 Duke ABS		12-		MCB 683 SV	SRQ			MCB 672 SH	SI	EC
	690 Duke R ABS		13-	*	MCB 792 SV	SRQ	CRQ		MCB 672 SH	SI	EC
	690 SMC R		12-	4☐	MCB 721 SV	SRQ	CRQ		MCB 672	RSI	EC
	690 Supermoto R		08-10	4☐	MCB 721 SV	SRQ	CRQ		MCB 672	RSI	EC
LC8	950 Adventure	KTM LC8	02-06	*	MCB 671	SV			MCB 648	SH	EC
LC8	950 Superenduro R		06-08		MCB 671	SV			MCB 648	SH	EC
LC8	950 Supermoto R		05-06	4☐ *	MCB 721 SV	SRQ	CRQ		MCB 648	RSI	EC
LC8	990 Adventure R, ABS		09-12	4☐ *	MCB 671	SV			MCB 648	SH	EC
LC8	990 Adventure S		06-08	4☐ *	MCB 671	SV			MCB 648	SH	EC
LC8	990 Super Duke	LC8EFI	05-11	4☐ *	MCB 721 SV	SRQ	CRQ		MCB 672 SH	SI	EC
LC8	990 Super Duke R	LC8EFI	08-	4☐ *	MCB 721 SV	SRQ	CRQ		MCB 672 SH	SI	EC
LC8	990 Supermoto R, ABS	LC8EFI	08-09	4☐ *	MCB 721 SV	SRQ	CRQ		MCB 648 SH	RSI	EC
LC8	990 Supermoto R, ABS		10-	*	MCB 792 SV	SRQ	CRQ		MCB 648 SH	RSI	EC
LC8	990 Supermoto T ABS		09-12	4☐ *	MCB 721 SV	SRQ	CRQ		MCB 648 SH	SI	EC
	1050 Adventure ABS		15-	*	MCB 683 SV				MCB 648	SH	EC
LC8	1190 Adventure R ABS		13-	4☐ *	MCB 721 SV				MCB 648	SH	EC
LC8	1190 Adventure ABS		13-	*	MCB 683 SV				MCB 648	SH	EC
RC8	1190 R		08-	*	MCB 792 SV	SRQ	CRQ	SCR	MCB 700	SH	RQ
	1290 Super Adventure ABS		15-	*	MCB 683 SV				MCB 648	SH	EC
	1290 Super Duke R ABS		14-	*	MCB 792 SV	SRQ	CRQ		MCB 700	SH	RQ

Kymco

RS	50 Agility 2T, 4T	U10/U60	10-		MCB 689	EC			MCS 800		
	50 Agility Basic 4T	U60	07		MCS 800				MCS 800		
	50 Agility City	C10	05-		MCB 689	EC			MCS 800		
	50 Agility, Carry, MMC, One	U60/U65	05-		MCB 689	EC			MCS 800		
	50 Bandit		02-06		MCB 582	SRM					
	50 Calypso	KCZ	97-99		MCB 694	EC			MCS 800		
	50 Cobra Cross	SF10	99-06		MCB 665	EC			MCS 800		
	50 Cobra Racer	SF10	00-06		MCB 665	EC			MCS 800		
CX	50 Curio	KCP	5/95-		MCB 665	EC			MCS 825		
	50 Dink, Dink Sports, Dink C.	SH10/S80	00-		MCB 663	EC			MCS 800		
	50 Easy		01-		MCB 665	EC			MCS 800		
ZX	50 Fever	KCA	5/95-		MCB 665	EC			MCS 825		
	50 Filly LX	SD10	00-06		MCB 689	EC			MCS 800		
	50 Grand Dink, S	S90	04-07		MCB 663	EC			MCS 800		
	50 Heroism	SB10	5/95-97		MCB 694	EC			MCS 800		
	50 Jive		04-06		MCB 590	EC			MCB 517		
	50 K-Pipe		12-		MCB 663	EC					
	50 Like 2T, 4 T		10-		MCB 689	EC			MCS 800		
	50 Like 2T, 4T		09		MCB 712	SRM			MCS 800		
	50 Manboy		97-		MCB 665	EC			MCS 800		
	50 Maxxer		05-12						MCS 843		
	50 Mxer Quad		00-07		MCS 800				MCB 712		
	50 MXU		05-		MCS 800				MCB 712		
RS	50 Naked 2T	U10/U60	10-		MCB 689	EC			MCS 800		
	50 New Sento i		11-		MCB 689	EC					
	50 Nexxon		08-09		MCB 822				MCB 822		
	50 People	B1	99-		MCB 712	SRM			MCS 826		



Option 1

Option 2

Option 3



Option 1

Option 2

Kymco

	50 People S	B1	99-		MCB 712	SRM			MCS 826		
	50 People	B9	07-		MCB 712	SRM			MCS 826		
	50 People S	B9	07-		MCB 712	SRM			MCS 826		
	50 Pronto		04-06		MCB 689	EC					
DJ	50 , Refined	SA10	94-06		MCS 800				MCS 825		
DJ	50 S	U61			MCB 712	SRM			MCS 825		
KB	50 Scout	KB	95-00		MCB 665	EC			MCS 800		
	50 Sento	U80	08-09		MCB 689	EC			MCS 800		
	50 Sniper		94-96		MCB 665	EC			MCB 686		
	50 Spacer	SH10	97-		MCB 663	EC			MCS 800		
K12	50 Sport	K12	95-00		MCB 665	EC			MCS 800		
CX	50 Super	KCP	5/95-97		MCB 665	EC			MCS 825		
	50 Super 8		08-		MCB 712	SRM			MCS 826		
	50 Super 9 AC	S1	00-07		MCB 663	EC			MCS 800		
	50 Super 9 LC	S1	00-07		MCB 663	EC			MCB 712		
ZX	50 Super Fever	SC10	02-		MCB 665	EC			MCS 825		
	50 Topboy on/off road	SF10	96-06		MCB 665	EC			MCS 800		
	50 Topboy Racer/Cross	SF10	97-06		MCB 665	EC			MCS 800		
	50 Vitality Cross, Sport	U3	04-		MCB 689	EC			MCS 800		
	50 Yager	SH10	98-		MCB 663	EC			MCS 800		
	50 Yup	S6	01-09		MCB 689	EC			MCS 800		
KB	90 Manboy		97-00		MCB 665	EC			MCS 800		
	100 Cobra Racer	SF10	98-03		MCB 689	EC			MCS 800		
KB	100 Scout		95-		MCB 665	EC			MCS 800		
	100 Topboy on/off road	SF10	97		MCB 665	EC			MCS 800		
	125 Agility 4 T	U62	06-		MCB 689	EC			MCS 826		
	125 Agility Carry		11-		MCB 712	SRM			MCS 800		
	125 Agility 16+		14-		MCB 712	SRM			MCB 663	SRM	EC
	125 Agility City	C20	08-		MCB 712	SRM			MCB 663	SRM	EC
	125 Agility MMC	U62	09-		MCB 712	SRM			MCS 800		
	125 Agility One	U62	05-		MCB 689	EC			MCS 800		
	125 Calypso	KAF	99-		MCB 694	EC			MCS 800		
	125 Dink	SH25	97-04		MCB 663	SRM	EC		MCB 663	SRM	EC
	125 Dink i	T90	06-		MCB 663	SRM	EC		MCB 663	SRM	EC
	125 Downtown i, Super Dink	V21	09-		MCB 598	SRM			MCB 830		
	125 Grand Dink	S40	01-07		MCB 663	SRM	EC		MCB 663	SRM	EC
	125 Grand Dink i.		12-		MCB 598	SRM			MCB 821	SRM	EC
	125 Heroism	KCZ/KAF	5/95-97		MCB 694	EC			MCS 800		
	125 Hipster		01-06		MCB 663	SRM	EC		MCS 821		
	125 Jetix		08-		MCB 525	EC					
	125 K-Pipe		12-		MCB 663	SRM	EC		MCS 821		
	125 K-XCTi		12-		MCB 726 SRM				MCB 821 SRM	EC	
	125 Like		09		MCB 712	SRM			MCB 663	SRM	EC
	125 Like, Like LX		10-		MCB 582	SRM			MCB 663	SRM	EC
	125 Movie XL	S51	01-09		MCB 689	EC			MCS 826		
	125 Mxer	L1	03-07		MCS 800				MCB 712		
	125 New Dink		08-		MCB 663	SRM	EC		MCB 663	SRM	EC
	125 Nexxon		08-		MCB 822				MCB 822		
	125 People GTi		10-		MCB 726	SRM			MCB 830	SRM	
	125 People One i		14-		MCB 712	SRM			MCS 826		
	125 People S		01-10	☎ ()	MCB 712	SRM			MCS 826		
	125 People S		07-	☎ ☐	MCB 712	SRM			MCB 821	SRM	EC
	125 Pulsar	M2	01-						MCS 800		
KR	125 Quannon		07-		MCB 663	SRM	EC		MCB 663	SRM	EC
DJ	125 S		12-		MCB 712				MCS 825		
	125 Spacer	SH25	97-		MCB 663	SRM	EC		MCB 663	SRM	EC
	125 Stryker on/off	AF	01-06		MCB 582	SRM			MCS 800		
	125 Super 8		08-		MCB 712	SRM			MCS 826		
	125 Super 9		00-		MCB 665	EC			MCB 712	SRM	
	125 Super Dink		10-		MCB 689	EC			MCB 830	SRM	
	125 Vivio		00-		MCB 689	EC			MCS 800		
	125 Yager GT	SH	07-		MCB 663	SRM	EC		MCB 663	SRM	EC
	125 Zing	RF25	96-		MCB 663	SRM	EC		MCS 817		



* 2 Sätze erforderlich – 2 sets required
Parkbremse – Parkingbrake



ohne Verschleißanzeige – without wear indicator
linke Seite – left side
rechte Seite – right side



Option 1

Option 2

Option 3



Option 1

Option 2

Kymco

	125 Zing II	RF30	96-		MCB 663	SRM	EC		MCS 817		
	150 Agility	C30	08-		MCB 712	SRM			MCB 663	SRM	EC
	150 Espresso		03-06		MCB 712						
	150 Heroism	KBF	5/95-		MCB 694	EC			MCB 686		
	150 Hipster		01-		MCB 663	SRM	EC		MCS 821		
	150 Movie, XL New C		97-		MCB 663	SRM	EC		MCS 826		
	150 Mxer	L1	03-07		MCS 800				MCB 712		
	150 MXU		05-		MCS 800				MCB 712		
	150 People	B20	01-04		MCB 712	SRM			MCS 826		
	150 Spacer		97-		MCB 663	SRM	EC		MCB 663	SRM	EC
	150 Straight		08-		MCB 822				MCB 822		
	150 Vivio		00-		MCB 582	SRM			MCS 826		
	150 Zing		96-		MCB 663	SRM	EC		MCS 817		
	200 Agility i		11-		MCB 712	SRM			MCB 663	SRM	EC
	200 Agility 16+		14-		MCB 712	SRM			MCB 663	SRM	EC
	200 Downtown		10-		MCB 598	SRM			MCB 830		
	200 Like i.		09		MCB 712	SRM			MCB 663	SRM	EC
	200 Like i.		10-		MCB 582	SRM			MCB 663	SRM	EC
	200 New Dink i.	T91	08-		MCB 663	SRM	EC		MCB 663	SRM	EC
	200 People	D11	05-06		MCB 712	SRM			MCS 826		
	200 People GTi		12-		MCB 726 SRM				MCB 830 SRM		
	200 People S i.	D12	07-		MCB 712	SRM			MCB 821	SRM	EC
	200 Yager GT i		04-		MCB 663 SRM	EC			MCB 663 SRM	EC	
	250 Dink		00-		MCB 663 SRM	EC			MCB 663 SRM	EC	
	250 Grand Dink	S40	00-06	4	MCB 732 SRM				MCB 733 SRM		
	250 Hawk		03-06		MCB 615 SRM	EC			MCB 733 SRM		
KXR	250 Mongoose Quad		04-07		* MCB 760 SI				MCB 732	SI	
	250 Maxxer		09-		* MCB 760 SI				MCB 760 SI		
	250 MXU		04-		* MCB 760 SI				MCB 732 SI		
	250 MXU R		11-		* MCB 760 SI				MCB 760 SI		
	250 People		03-06		MCB 663 SRM				MCB 663 SRM		
	250 People		07-08		MCB 582 SRM				MCB 821 SRM	EC	
	250 People		07-08		MCB 615 SRM	EC					
	250 Super-9		00-		MCB 665	EC			MCB 712	SRM	
	250 Urban Quad		06		MCB 769 SI				MCB 769 SI		
	250 Venox		01-		MCB 598 SRM				MCB 598 SRM		
	250 Xciting	T71	04-05		MCB 598 SRM				MCB 598 SRM		
	250 Xciting i	T71	06-08		MCB 598 SRM				MCB 821 SRM	EC	
	300 Downtown i, ABS		10-		MCB 598 SRM				MCB 830 SRM		
	300 Grand Dink i.		12-		MCB 598 SRM				MCB 821 SRM	EC	
	300 K-XCTi		12-		MCB 726 SRM				MCB 821 SRM	EC	
	300 Maxxer		06-09		* MCB 760 SI				MCB 732		
	300 Maxxer		10-		* MCB 760 SI				MCB 732		
	300 Maxxer		10-						MCB 832 P		
	300 Maxxer Supermoto		15-		* MCB 760 SI				MCB 732 SI		
	300 MXU		05-		* MCB 760 SI				MCB 760 SI		
	300 People GTi		10-		MCB 598 SRM				MCB 830 SRM		
	300 People S i		08-10		MCB 582 SRM				MCB 821 SRM	EC	
	300 People S i		08-10		MCB 615 SRM						
	300 Xciting i R		08-		* MCB 598 SRM				MCB 821 SRM	EC	
	400 Maxxer		09-		* MCB 773 SI				MCB 773 SI		
	400 Maxxer		09-						MCB 875 P		
	400 MXU		08-		* MCB 760 SI				MCB 760 SI		
	400 MXU		08-						MCB 875 P		
	400 Xciting i		12-		* MCB 847 SRM				MCB 845 SRM		
	450 Grumbler i.		13-		* MCB 773 SI				MCB 773 SI		
	450 Maxxer i		09-		* MCB 773 SI				MCB 773 SI		
	450 Maxxer i		09-						MCB 875 P		
	450 MXU i		13-		* MCB 760 SI				MCB 760 SI		
	450 MXU i		13-						MCB 875 P		
	500 MXU		05-		* MCB 760 SI				MCB 760 SI		
	500 Xciting		05-		* MCB 598 SRM				MCB 845 SRM		
	500 Xciting i Evo ABS		11-		* MCB 598 SRM				MCB 845 SRM		
	500 Xciting R ABS		09-		* MCB 598 SRM				MCB 845 SRM		
UXV	500		08-		* MCB 760 SI				MCB 760 SI		



Option 1

Option 2

Option 3



Option 1

Option 2

Kymco

700 Myroad i ABS	09-	*	MCB 598 SRM				MCB 845 SRM		
------------------	-----	---	-------------	--	--	--	-------------	--	--

Laverda

50 Quasar	04-		MCS 832				MCS 805		
100 Quasar	04-		MCS 832				MCS 805		
125 Phoenix	01-04						MCB 712		
HP 125 Quasar	04-						MCB 763 SI		
HP 180 Quasar	04-						MCB 763 SI		
350 Alpino		*	MCB 75				MCB 75		
GS 350 Lesmo	86	*	MCB 75				MCB 75		
350 PF		*	MCB 75				MCB 75		
350 RS		*	MCB 75				MCB 75		
400 Quasar 4x4	04-	*	MCB 763 SI				MCB 763 SI		
500 Alpino S	77-	*	MCB 75				MCB 75		
500 Quasar 4x4	04-	*	MCB 763 SI				MCB 763 SI		
SFC 500		*	MCB 19				MCB 19		
OR 600 Atlas	86		MCB 563				MCB 75		
600 SF2, SF3	74-78	*	MCB 19						
SFC 600	86	*	MCB 19				MCB 19		
650 Formula	95-	*	MCB 540	SV			MCB 75	RQ	
650 Ghost	96-	*	MCB 540	SV			MCB 75	RQ	
650 Legend	96-	*	MCB 540	SV			MCB 75	RQ	
650 Lynx	00-	*	MCB 540	SV			MCB 75	RQ	
650 Sport	ZLVSTA	95-	*	MCB 540	SV		MCB 75	RQ	
650 Strike		96-	*	MCB 540	SV		MCB 75	RQ	
668 Ghost	ZLVSPA	96-	*	MCB 540	SV		MCB 75	RQ	
668 Strike		96-	*	MCB 540	SV		MCB 75	RQ	
750 Cup		98-	*	MCB 540	SV		MCB 75	RQ	
750 Diamante	ZLVSPA	98-	*	MCB 540	SV		MCB 75	RQ	
750 S Formula	ZLVSTA	98-	*	MCB 540	SV		MCB 75	RQ	
750 S, S Carenata		98-	*	MCB 540	SV		MCB 75	RQ	
750 Sport, Supersport		99-	*	MCB 540	SV	SRQ	CRQ	MCB 75	RQ
750 Strike		98-	*	MCB 540	SV		MCB 75	RQ	
750 T8		98-	*	MCB 540	SV		MCB 75	RQ	
TTS 800		99-	*	MCB 540	SV	SRQ	CRQ	MCB 701	
1000	78-86	*	MCB 19	RQ			MCB 19	RQ	
1000 Executive	83-86	*	MCB 19	RQ			MCB 19	RQ	
1000 Jota	76-	*	MCB 19	RQ			MCB 19	RQ	
RGA 1000 Jota	86	*	MCB 19	RQ			MCB 19	RQ	
RGS 1000	83-86	*	MCB 19	RQ			MCB 19	RQ	
SFC 1000	85	*	MCB 19	RQ			MCB 19	RQ	
TGA 1000	83-86	*	MCB 19	RQ			MCB 19	RQ	
150 Phoenix	01-04						MCB 712		
250 Phoenix	01-04						MCB 712		

Lifan

125 Offroad	07-		MCB 844				MCB 846		
LF 50 Ogy (Aero 50)			MCB 590	EC			MCS 800		

Linhai

125 Eggy	07-		MCB 539	EC					
LH 50 Police	07-		MCB 539	EC					

LML-Vespa

Star 125 Deluxe			MCB 651				MCS 980		
NV 150	95-		MCS 980				MCS 980		
T5 150	95-		MCS 980				MCS 980		
NV 200	95-		MCS 980				MCS 980		
T5 200	95-		MCS 980				MCS 980		

Maico

250 Motocross/Enduro	99-		MCB 648 SI	RSI	EC		MCB 672 SI	RSI	EC
500 Motocross/Enduro	99-		MCB 648 SI	RSI	EC		MCB 672 SI	RSI	EC
500 Supermotard	99-		MCB 648 SI	RSI	EC		MCB 672 SI	RSI	EC



* 2 Sätze erforderlich – 2 sets required
Parkbremse – Parkingbrake



ohne Verschleißanzeige – without wear indicator



linke Seite – left side



rechte Seite – right side



Option 1

Option 2

Option 3



Option 1

Option 2

Maico

Alle Modelle

86-

MCB 550

MCB 550

Malaguti

MDX	50		86-									
MEX	50		86-									
MFX	50		86-									
MRX	50		89						SI			
RST	50		90									
	50 Centro		08-									
	50 Centro	ZJM36	94-96									
	50 Centro	ZJM42	97-									
	50 Ciak	ZJM52	00-									
	50 Ciak Twin Disk	ZJM52	02-									
CR-1	50 Crosser	ZJM43	95-97									
CR-1	50 Crosser	ZJM43	98-									
	50 CX		85-									
NKD	50 Drakon		05-									
	50 Enduro		85-									
Dune	50 ES		89									
	50 Fifty Full		85-									
	50 Fifty Mistral		90-									
F-15	50 Firefox	ZJM44	96-98									
F-15	50 Firefox	ZJM44	98-									
F-15	50 Firefox LC	ZJM44	01-									
F-10	50 Jetline		92-93									
F-10	50 Jetline		94-									
F-15	50 Mechatronic		03-									
F-12	50 Phantom	ZJM62	94-97									
F-12	50 Phantom	ZJM62	98-									
F-12R	50 Phantom AC	ZJM62	02-									
F-12R	50 Phantom LC	ZJM62	00-									
	50 Raid		91-									
XL	50 Sport		83-									
	50 Top		85-									
F-10	50 Tribal		08-									
F-10	50 WAP	ZJM48	03-									
	50 Yesterday	ZJM45	97-									
	80 Chopper Fifty		83-									
F-12	100 Phantom	ZJM50	00-									
	125 Blog i.e.		09-									
	125 Centro i.e.		08-									
	125 Ciak, Ciak Master	ZJM59	02-									
	125 Madison	ZJM53	99-									
	125 Madison 3		08-									
MFX	125 Runner		86-									
MFX	125 Runner		87-									
	125 Sport City Cube		08-									
F-18	125 Warrior	ZJM57	00-03									
F-18	150 Warrior		00-03									
	160 Blog i.e.		09-									
	160 Centro i.e.		08-									
	200 Madison		03-									
	200 Sport City Cube		08-									
	250 Madison	ZJM54	00-03									
	250 Madison 3 i.e.		08-									
	250 Password i.e.		06-									
	250 Sport City Cube		08-									
	300 Sport City Cube		08-									
K	400 Madison	ZJM61	01-									
MGX	425 Ronco		87-									
MGX	450 Ronco		87-									
GT	500 Spidermax		04-									
RS	500 Spidermax		09-									



Option 1

Option 2

Option 3



Option 1

Option 2

Malanca

GTI	80			*	MCB 552				MCB 552		
GTI	125			*	MCB 552				MCB 552		
	125 Mark		85-		MCB 75						
E2	125 Sport			*	MCB 552				MCB 552		

Massey Ferguson

MF	250 2WD/4WD		04	*	MCB 763 SI				MCB 763 SI		
MF	300 2WD/4WD		04	*	MCB 763 SI				MCB 763 SI		
MF	400 4WD		04	*	MCB 763 SI				MCB 763 SI		
MF	400 4WD Auto		04	*	MCB 763 SI				MCB 763 SI		
MF	500 4WD TBX Auto		04	*	MCB 763 SI				MCB 763 SI		
MF	500 4WD Auto		05-09	*	MCB 773 SI				MCB 773 SI		
MF	650 4WD Auto		05-09	*	MCB 773 SI				MCB 773 SI		
MF	700 4WD Auto Diesel		05-09	*	MCB 773 SI				MCB 773 SI		

MBK

BW	50 alle Modelle		90-96		MCS 956				MCS 956		
CW	50 Booster Next Generation	4BXM	96-		MCB 644	EC			MCS 962		
CW	50 Booster Road	4BXM	94-95		MCB 644	EC			MCS 962		
CW	50 Booster Rocket	4VA	95-		MCB 644	EC			MCS 962		
CW	50 Booster Spirit	SA05	00-		MCB 674	EC	SR		MCS 962		
CW	50 Booster Track	4VA	96-		MCB 644	EC			MCS 956		
CV	50 Evolis	4FW	92		MCB 644	EC			MCS 962		
CV	50 Evolis	4FW	93-		MCB 590	EC			MCS 962		
CW	50 Fizz	4RC	94-97		MCB 644	EC			MCS 962		
YH	50 Flipper	SA03	99-		MCB 674	EC	SR		MCS 956		
CY	50 Forte	3UG	96-		MCB 644	EC			MCS 962		
CS	50 Mach G	SA22	02-10		MCB 644	EC			MCS 962		
YP	50 Nitro	SA14	01-		MCB 644	EC			MCB 701	EC	SR
YP	50 Nitro	5BR	97-00		MCB 644	EC			MCB 701	EC	SR
YN	50 Ovetto	5AD	96-		MCB 644	EC			MCS 962		
EW	50 Stunt	SA09	00-		MCB 701	EC	SR		MCS 962		
	50 X-Power		04-		MCB 734	EC			MCB 539	EC	
CV	80 Evolis	4FW	94-		MCB 590	EC			MCS 962		
YW	100 Booster	SB02	01-		MCB 590	EC			MCS 968		
YP	100 Nitro	SB05	00-		MCB 674	EC	SR		MCS 968		
YN	100 Ovetto	SB04	00-		MCB 674	EC	SR		MCS 968		
XN	125 Doodo	SE04	00-05		MCB 674	EC	SR		MCS 968		
NXC	125 Flame		05-09		MCB 774				MCS 962		
NXC	125 Flame		10-		MCB 839				MCS 962		
XC	125 Flame	SE03	96-04		MCB 539	EC			MCS 962		
YP	125 Skycruiser	SE32	06-		MCB 648	SRM			MCB 700	SRM	
YP	125 Skyliner	SE06	01-		MCB 648	SRM			MCB 700	SRM	
YP	125 Skyliner	5DS	96-00		MCB 648	SRM			MCS 968		
XQ	125 Thunder	SE05	01-		MCB 648	SRM			MCB 700	SRM	
YW	125 Z X-over		10-		MCB 835						
YP	150 Skyliner	SG08	98-00		MCB 666	SRM			MCS 958		
YP	150 Skyliner R	SG08	01-		MCB 666	SRM			MCB 700	SRM	
XQ	150 Thunder	SG06	02-		MCB 648	SRM			MCB 700	SRM	
YP	180 Skyliner	SG12	04-		MCB 648	SRM			MCB 700	SRM	
YP	250 Skyliner	SG02	00-		MCB 666 SRM				MCB 699 SRM		
VP	300 Kilibre		03-		MCB 648 SRM				MCB 648 SRM		
VP	400 Skyliner	SH05	04-		MCB 666 SRM				MCB 722 SRM		

Montesa

	Alle Modelle		88-		MCB 535	RQ	EC		MCB 75	RQ	
--	--------------	--	-----	--	---------	----	----	--	--------	----	--

Moto Guzzi

	125 Custom		85		MCB 75						
	350 Falcone		88		MCB 75	RQ			MCB 75		
	350 Imola		78	*	MCB 75	RQ			MCB 75		
	350 NTX		88-	*	MCB 75	RQ			MCB 75		
	400		79	*	MCB 75	RQ			MCB 75		
	500 Monza		77-85	*	MCB 75	RQ			MCB 75		



* 2 Sätze erforderlich – 2 sets required
Parkbremse – Parkingbrake



ohne Verschleißanzeige – without wear indicator



linke Seite – left side



rechte Seite – right side



Option 1

Option 2

Option 3



Option 1

Option 2

Moto Guzzi

	650		80-85		*	MCB 75	RQ		MCB 75		
	650 Florida		92		*	MCB 75	RQ		MCB 75		
	650 GT Sessantacinque		89		*	MCB 75	RQ		MCB 75		
	650 Nevada		92-01		*	MCB 75			MCB 75		
	650 NTX		87-			MCB 19			MCB 19		
V	750 Breva i.e.	LL	03-			MCB 683	SV		MCB 700	RQ	
V7	750 Classic		09-11			MCB 683	SV		MCB 700	RQ	
V7	750 Cafe Classic		09-11			MCB 683	SV		MCB 700	RQ	
V7	750 Racer		09-11			MCB 683	SV		MCB 700	RQ	
V7	750 Racer		12-14			MCB 683	SV		MCB 557		
V7	750 Special		12-14			MCB 683	SV		MCB 557		
V7	750 Stone		12-14			MCB 683	SV		MCB 557		
V7	750 II Racer		15-			MCB 683	SV		MCB 557		
V7	750 II Special		15-			MCB 683	SV		MCB 557		
V7	750 II Stone		15-			MCB 683	SV		MCB 557		
	750 Enduro		86		*	MCB 19			MCB 19		
	750 Nevada		92-02		*	MCB 75			MCB 75		
	750 Nevada	LK	03-			MCB 683	SV		MCB 700	RQ	
	750 Nevada Classic	LK	03-			MCB 683	SV		MCB 700	RQ	
	750 NTX		90-			MCB 19	SV		MCB 19		
	750 SP		92-		*	MCB 75	RQ		MCB 75	RQ	
	750 T		92-		*	MCB 75	RQ		MCB 75	RQ	
	750 Targa		92-		*	MCB 75	RQ		MCB 75	RQ	
	850 Breva		05-		*	MCB 683	SV		MCB 648	SH	
	850 Griso		05-		*	MCB 683	SV		MCB 648	SH	
	850 Le Mans		76-85		*	MCB 19	RQ		MCB 19		
	850 Norge		06-		*	MCB 683	SV		MCB 648	SH	
	850 T3, T4, T5		76-85		*	MCB 19	RQ		MCB 19	RQ	
	850 T5 N.T.		86		*	MCB 19	RQ		MCB 19	RQ	
	940 Bellagio		07-		*	MCB 671	SV		MCB 648	SH	
	1000 California I		81-		*	MCB 533			MCB 533		
	1000 California II	VT	85		*	MCB 19	RQ		MCB 19	RQ	
	1000 California III	VW	89		*	MCB 19	SV		MCB 19	RQ	
	1000 California III C		91-		*	MCB 19	SV		MCB 19	RQ	
V10	1000 Centauro	KK	96-		*	MCB 540	SV		MCB 75	RQ	
RS	1000 Daytona	KL	97-		*	MCB 540	SV		MCB 75	RQ	
	1000 Le Mans III		79-84			MCB 19	RQ		MCB 533		
	1000 Le Mans IV		85		*	MCB 19	RQ		MCB 19	RQ	
	1000 Mille GT		91-		*	MCB 19	SV		MCB 19	RQ	
	1000 Quota I.E.		92-			MCB 572			MCB 618		
	1000 S		90		*	MCB 19	SV		MCB 19	RQ	
	1000 SP		79-84			MCB 19	RQ		MCB 533		
	1100 Breva	KR	04-		*	MCB 683	SV		MCB 671	SH	
EV	1100 California	KC	94-97		*	MCB 19	SV		MCB 19	RQ	
EV	1100 California	KC	98-00		*	MCB 540	SV		MCB 75	RQ	
	1100 California Jackal	KD	00			MCB 540	SV		MCB 671	SH	
	1100 California Jackal	KD	01-			MCB 683	SV		MCB 671	SH	
	1100 California Special	KD	01-		*	MCB 683	SV		MCB 671	SH	
	1100 California Special	KD	99-00		*	MCB 540	SV		MCB 671	SH	
	1100 California Special Sport	KD	02-		*	MCB 683	SV	SRQ	CRQ	MCB 671	SH
	1100 California Stone	KD	02-			MCB 683	SV		MCB 671	SH	
	1100 California Titanium	KD	03-		*	MCB 683	SV		MCB 671	SH	
	1100 California Vintage		06-		*	MCB 683	SV		MCB 671	SH	
EV	1100 California, 80, Touring	KD	01-			MCB 683	SV		MCB 75	RQ	
	1100 Griso	LS	05-		*	MCB 683	SV		MCB 700	SH	RQ
V11	1100 Le Mans, Le Mans Tenni	KR	01-		*	MCB 683	SV	SRQ	CRQ	MCB 75	RQ
ES	1100 Quota	KM	99-		*	MCB 671	SV		MCB 648	SH	
V11	1100 Scura, Sport Scura	KR	02-		*	MCB 683	SV	SRQ	CRQ	MCB 75	RQ
	1100 Sport	KE	96-		*	MCB 540	SV	SRQ	CRQ	MCB 75	RQ
V11	1100 Sport	KR	97-00		*	MCB 540	SV	SRQ	CRQ	MCB 75	RQ
V11	1100 Sport, Sport Naked	KR	01-		*	MCB 683	SV	SRQ	CRQ	MCB 75	RQ
	1200 Breva	LP	08-11		*	MCB 683 SV			MCB 648	SH	
	1200 Breva ABS	LP	08-11		*	MCB 683 SV			MCB 648	SH	
	1200 Griso 8V, SE	LS	07-		4☐*	MCB 721 SV	SRQ	CRQ	MCB 648	SH	
	1200 MGS-01 Corsa		05-		4☐*	MCB 721 SV	SRQ	CRQ	MCB 700	SH	RQ



Option 1

Option 2

Option 3



Option 1

Option 2

Moto Guzzi

	1200 Norge	LS	06-10	*	MCB 683 SV				MCB 648	SH	
	1200 Norge GT 8V ABS		11-	*	MCB 683 SV				MCB 648	SH	
	1200 Sport 4V	LP	06-07	*	MCB 683 SV	SRQ	CRQ	SCR	MCB 648	SH	
	1200 Sport 4V ABS	LP	08-12	*	MCB 683 SV	SRQ	CRQ	SCR	MCB 700	SH	RQ
	1200 Sport 8V Corsa ABS		12-	*	MCB 683 SV	SRQ	CRQ	SCR	MCB 648	SH	
	1200 Stelvio, NTX ABS	LZ	08-	*	MCB 683 SV	SRQ	CRQ	SCR	MCB 648	SH	
V11	1200 Le Mans, Corsa		05-	4□ *	MCB 721 SV	SRQ	CRQ		MCB 700	SH	RQ
	1400 California Custom		13-	*	MCB 683 SV				MCB 671 SH		
	1400 California Touring		13-	*	MCB 683 SV				MCB 671 SH		

Moto Morini

	125 KJ		86		MCB 536						
	250 XE Country		88		MCB 75						
	350 Dart		88		MCB 579				MCB 75		
	350 Excalibur		86		MCB 563				MCB 563		
	350 Indiana		88		MCB 563				MCB 75		
	350 K2		86		MCB 536						
	350 Kanguro		86		MCB 536						
	350 Kanguro		88		MCB 557				MCB 75		
	1200 9.5	ZLM	07-11	*	MCB 683	SV	SRQ	CRQ	MCB 700	RQ	
	1200 Corsaro	ZLM	05-	*	MCB 683	SV	SRQ	CRQ	MCB 700	RQ	
	1200 Granpasso	ZLM	08-	*	MCB 671	SV			MCB 648	SH	
	1200 Sport		08-	*	MCB 683 SV	SRQ	CRQ		MCB 700	SH	RQ
	1200 Rebello		12-	*	MCB 721 SV	SRQ	CRQ		MCB 700	SH	RQ
	1200 Scrambler	ZLM	08-09	*	MCB 683 SV	SRQ	CRQ		MCB 700	SH	RQ
	1200 Scrambler	ZLM	10-	*	MCB 671	SV			MCB 648	SH	

Motorhispania

RYZ	50 Enduro		05-		MCB 535	EC			MCB 535	EC	
MH	50 Furia 6v	FU01	99-		MCB 535	EC			MCB 535	EC	
MH	50 Furia Max		06-		MCB 535	EC			MCB 535	EC	
RX	50 Racing	DR01	00-		MCB 629				MCB 535	EC	
MH	50 Urban Bike		06-		MCB 734	EC			MCB 535	EC	
RYZ	125 Enduro		05-		MCB 535	EC			MCB 535	EC	

MUZ

FB	50 Moskito	FB	98-		MCB 590	EC					
SX	50 Moskito	JP	00-		MCB 519	EC	SR		MCS 962		
RT	125 Classic		00-		MCB 663				MCB 604		
MZ	125 Mantizz S		07-		MCB 525	EC					
FB	125 Moskito		98-		MCB 590	EC					
MZ	125 Saxon Roadstar		93-		MCB 19	SV			MCS 891		
MZ	125 Saxon Sportstar		93-		MCB 19	SV			MCS 891		
SM	125	MZ125	02-		MCB 689				MCB 604		
SM	125		99-01		MCB 582	SI			MCB 604		
SX	125	MZ125	02-		MCB 689				MCB 604		
SX	125		99-01		MCB 582	SI			MCB 604		
MZ	251 Saxon Fun		93-		MCB 19	SV			MCS 890		
MZ	251 Saxon Sportstar		93-		MCB 19	SV			MCS 891		
MZ	251 Saxon Tour		93-		MCB 19	SV			MCS 890		
MZ	301 Saxon		93-	cast wheel	MCB 19	SV			MCS 891		
MZ	301 Saxon Fun		93-		MCB 19	SV			MCS 890		
MZ	301 Saxon Sportstar		93-		MCB 19	SV			MCS 891		
MZ	301 Saxon Tour		93-		MCB 19	SV			MCS 890		
MZ	500 Green Star		97-		MCB 19	SV			MCS 890		
MZ	500 R		90-		MCB 19	SV			MCS 890		
MZ	500 Red Star		97-		MCB 19	SV			MCS 890		
MZ	500 Saxon		93-	cast wheel	MCB 19	SV			MCS 891		
MZ	500 Saxon Country		93-		MCB 19	SV			MCS 890		
MZ	500 Saxon Fun		93-		MCB 19	SV			MCS 890		
MZ	500 Saxon Tour		93-		MCB 19	SV			MCS 890		
MZ	500 Silver Star Classic		93-		MCB 19	SV			MCS 890		
MZ	660 Baghira	MKZ660E	97-01		MCB 652				MCB 657		
MZ	660 Baghira Black Panther	MKZ660E	00-		MCB 652				MCB 657		



* 2 Sätze erforderlich – 2 sets required
Parkbremse – Parkingbrake



ohne Verschleißanzeige – without wear indicator



linke Seite – left side



rechte Seite – right side



Option 1

Option 2

Option 3



Option 1

Option 2

MUZ

MZ	660 Mastiff	MKZ660E	98-						MCB 652					MCB 657		
MZ	660 Skorpion Cup		00-						MCB 540 SV	SRQ	CRQ			MCB 75		
MZ	660 Skorpion Replica		97-				*		MCB 540 SV	SRQ	CRQ			MCB 75		
MZ	660 Skorpion Sport	MKZ660	94-01				*		MCB 540	SV				MCB 75		
MZ	660 Skorpion Tour	MKZ660	94-01				*		MCB 540	SV				MCB 75		
MZ	660 Skorpion Traveller		97-01						MCB 540	SV				MCB 75		
MZ	660 Supermoto		06-						MCB 652					MCB 657		
MZ	1000 S		01-02				*		MCB 683	SV	SRQ	CRQ		MCB 700	RQ	
MZ	1000 S		03-				*		MCB 595	SV	SRQ	CRQ		MCB 691	SH	
MZ	1000 SF, SFs		05-				*		MCB 595	SV	SRQ	CRQ		MCB 691	SH	
MZ	1000 SFX		07-				*		MCB 595	SV	SRQ	CRQ		MCB 691	SH	
MZ	1000 ST		05-				*		MCB 595	SV	SRQ	CRQ		MCB 691	SH	

MV Agusta

	675 Brutale, ABS		12-				*		MCB 683 SV	SRQ	CRQ	SCR		MCB 700	SH	RQ
F3	675 , ABS		11-14				*		MCB 683 SV	SRQ	CRQ	SCR		MCB 700	SH	RQ
F3	675 , ABS		15-				*		MCB 721 SV	SRQ	CRQ	SCR		MCB 700	SH	RQ
F4	750	F4	99-03				*		MCB 660 SV	SRQ	CRQ			MCB 797 SH		
	750 Brutale, Brutale S	F4	01-06				*		MCB 660 SV	SRQ	CRQ			MCB 797 SH		
	800 Brutale, ABS		13-				*		MCB 683 SV	SRQ	CRQ			MCB 700	SH	RQ
	800 Brutale Dragster ABS		15-				*		MCB 683 SV	SRQ	CRQ			MCB 700	SH	RQ
	800 Rivale, ABS		13-				*		MCB 856 SV	SRQ	CRQ			MCB 700	SH	RQ
	800 Stradale ABS		15-				*		MCB 856 SV	SRQ	CRQ			MCB 700	SH	RQ
F3	800 , ABS		14-				*		MCB 792 SV	SRQ	CRQ	SCR		MCB 797 SH		
	800 Turismo Veloce ABS		14-				*		MCB 856 SV	SRQ	CRQ			MCB 700	SH	RQ
	910 Brutale R		05-07	Brembo	4☐		*		MCB 721 SV	SRQ	CRQ	SCR		MCB 797 SH		
	910 Brutale S		05-07	Nissin			*		MCB 660 SV	SRQ	CRQ			MCB 797 SH		
	920 Brutale		12-				*		MCB 683 SV	SRQ	CRQ	SCR		MCB 797 SH		
	989 Brutale		08-09				*		MCB 683 SV	SRQ	CRQ	SCR		MCB 797 SH		
	990 Brutale R		10-11				*		MCB 683 SV	SRQ	CRQ	SCR		MCB 797 SH		
F4	1000 R		07-	Brembo	4☐		*		MCB 721 SV	SRQ	CRQ	SCR		MCB 797 SH		
F4	1000 R, RR ABS		10-				*		MCB 792 SV	SRQ	CRQ	SCR		MCB 797 SH		
F4	1000 R Corsa, RR Corsa		12-				*		MCB 792 SV	SRQ	CRQ	SCR		MCB 797 SH		
F4	1000 S	F4	04-	Nissin			*		MCB 660 SV	SRQ	CRQ			MCB 797 SH		
	1078 Brutale RR		08-09				*		MCB 792 SV	SRQ	CRQ	SCR		MCB 797 SH		
F4	1078 CC		08-11				*		MCB 792 SV	SRQ	CRQ	SCR		MCB 797 SH		
F4	1078 RR		08-11				*		MCB 792 SV	SRQ	CRQ	SCR		MCB 797 SH		
	1090 Brutale ABS		12-				*		MCB 683 SV	SRQ	CRQ	SCR		MCB 797 SH		
	1090 Brutale R ABS		12-				*		MCB 683 SV	SRQ	CRQ	SCR		MCB 797 SH		
	1090 Brutale RR ABS		10-				*		MCB 792 SV	SRQ	CRQ	SCR		MCB 797 SH		
	1090 Brutale RR Corsa ABS		14-				*		MCB 792 SV	SRQ	CRQ	SCR		MCB 797 SH		

MZ

ETZ	125		85-						MCB 19					MCS 891		
TS	125								MCS 890					MCS 891		
ETZ	250		82-						MCB 19					MCS 890		
ETZ	250		85-						MCB 19					MCS 890		
TZ	250								MCS 890					MCS 890		
ETZ	251		89						MCB 19					MCS 890		
ETZ	301 Kanui								MCB 19					MCS 890		

MZB

	125 Horex Imperator		96-						MCB 676							
	125 Horex Regent		96-						MCB 19							
	125 MZB RT-Classic		96-						MCB 19							

Norton

	Commander		90-				*		MCB 19					MCB 19		
	F-1		90				*		MCB 19					MCB 19		
	Interpol 2		83				*		MCB 19					MCB 19		
	TT		92				*		MCB 540 SV	SRQ	CRQ			MCB 540		
	Wankel Classic		88				*		MCB 19					MCB 19		
	850 Commando		73-77						MCB 18					MCB 18		
	961 Commando Cafe Racer		10-				4☐	*	MCB 721 SV	SRQ	CRQ			MCB 700	SH	RQ
	961 Commando SE		10-11					*	MCB 683 SV	SRQ	CRQ			MCB 700	SH	RQ
	961 Commando SE		12-				4☐	*	MCB 721 SV	SRQ	CRQ			MCB 700	SH	RQ



Option 1

Option 2

Option 3



Option 1

Option 2

Norton

961 Commando SF	13-		4 *	MCB 721 SV	SRQ	CRQ		MCB 700	SH	RQ
961 Commando SF Sport	10-		*	MCB 683	SV	SRQ	CRQ	MCB 700	SH	RQ

Peugeot

50 Blaster Furios		09-		MCB 535	EC	SR		MCB 535	EC	SR
50 Buxy		94-	AJP	MCB 535	EC	SR		MCS 800		
50 Buxy	FE 053 DE	94-	Brembo	MCB 696	EC	SR		MCS 800		
50 Buxy		94-	Hengtong	MCB 519	EC	SR		MCS 800		
50 Elyseo	GA1	02-		MCB 535	EC	SR		MCB 535	EC	SR
50 Elyseo	G1A	98-01	AJP	MCB 535	EC	SR		MCS 800		
50 Elyseo	G1A	98-01	Hengtong	MCB 519	EC	SR		MCS 800		
50 Elystar Advantage	G1A	02-07		MCB 535	EC	SR		MCB 735	EC	
TKR	50 Furios, WRC	S1B	03-	MCB 535	EC	SR		MCB 535	EC	SR
SV	50 Geo, L	F 052-DE	93-	MCB 650				MCB 575		
SV	50 J, Junior	F 052-DE	93-	MCS 800				MCS 800		
	50 Jet-Force, Jet-C Tech	A1	03-	MCB 535	EC	SR		MCB 535	EC	SR
	50 Kisbee RS	K1	10-	MCB 519	EC	SR		MCS 800		
	50 Looxor	B1	01-05	MCB 535	EC	SR		MCS 800		
	50 Looxor TSDi	B2	06-	MCB 535	EC	SR		MCB 535	EC	SR
	50 Ludix 2 T	L1	07-	MCB 535	EC	SR		MCS 800		
	50 Ludix Blaster	L1	04-	MCB 535	EC	SR		MCS 800		
	50 Ludix One/Classic		04-	MCS 800				MCS 800		
	50 Ludix Snake/Trend/Eleganc	L1	04-	MCB 535	EC	SR		MCS 800		
	50 New Vivacity	V1A	08-	MCB 510				MCS 800		
XR-6	50 Race Spec	DR01	02-07	MCB 629				MCB 535	EC	SR
	50 Speedake		94-	AJP	MCB 535	EC	SR	MCS 800		
	50 Speedake	FE 053 DE	94-	Brembo	MCB 696	EC	SR	MCS 800		
	50 Speedake		94-	Hengtong	MCB 519	EC	SR	MCS 800		
	50 Speedfight 2 AC	S1B	01-	MCB 535	EC	SR		MCS 800		
	50 Speedfight 2 LC	S1B	01-	MCB 535	EC	SR		MCB 535	EC	SR
	50 Speedfight 2 X-Race	S1B	03-	MCB 535	EC	SR		MCB 535	EC	SR
	50 Speedfight 3 AC	F1	10-	MCB 822				MCS 800		
	50 Speedfight 3, RS LC	F1	10-	MCB 822				MCB 700	EC	
	50 Speedfight AC	S1BDE	96-00	AJP	MCB 535	EC	SR	MCS 800		
	50 Speedfight LC	S1BDE	96-00	AJP	MCB 535	EC	SR	MCB 535	EC	SR
	50 Speedfight LC	S1BDE	96-00	Brembo	MCB 674	EC	SR	MCS 800		
	50 Speedfight Le Mans	F1	10-	MCB 535	EC	SR		MCB 535	EC	SR
	50 Squab		94-98	AJP	MCB 535	EC	SR	MCS 800		
	50 Squab		94-98	Hengtong	MCB 519	EC	SR	MCS 800		
XPS-6	50 Supermotard		04-	MCB 734	EC			MCB 535	EC	SR
	50 Trekker Metal-X	S1A	01-	MCB 535	EC	SR		MCS 800		
	50 Trekker Offroad	S1ADE	99-	Hengtong	MCB 519	EC	SR	MCS 800		
	50 Trekker Road	S1ADE	99-	MCB 535	EC	SR		MCS 800		
	50 Trekker Streetboard	S1A	00-	MCB 535	EC	SR		MCS 800		
	50 Trekker Urban Black	S1A	00-	MCB 535	EC	SR		MCS 800		
XP-6	50 Trial, Enduro	DV1C	06-	MCB 535	EC	SR		MCB 535	EC	SR
	50 Tweet	LW1	10-	MCB 684	EC			MCS 800		
	50 Tweet RS	LW1	10-	MCB 684	EC			MCB 695	EC	SR
	50 V-Clic	AG	08-	MCB 590	EC			MCS 800		
	50 Vivacity	S1C	99-09	AJP	MCB 535	EC	SR	MCS 800		
	50 Vivacity	S1C	99-09	Hengtong	MCB 519	EC	SR	MCS 800		
	e- Vivacity	V4	10	Electric	MCB 694	EC		MCS 800		
	e- Vivacity	V4	11-	Electric	MCB 689	EC		MCS 800		
	50 Zenith		94-	MCS 813				MCS 800		
	50 Zenith Luxe		94-	MCB 696	EC	SR		MCS 800		
XR-7	50	RX50	08-	MCB 780				MCB 535	EC	SR
SV	80	F 082-DE	91-92	MCB 650				MCS 800		
SV	80	F 082-DE	93-	MCB 665	EC			MCS 800		
	80 Metropolis			MCS 800				MCS 813		
	100 Elyseo	G2A	02-	AJP	MCB 535	EC	SR	MCB 535	EC	SR
	100 Elyseo	G2A	98-01	AJP	MCB 535	EC	SR	MCS 800		
	100 Looxor	B1A	01-	AJP	MCB 535	EC	SR	MCB 535	EC	SR
	100 Speedfight	S2A	00-	AJP	MCB 535	EC	SR	MCB 535	EC	SR



* 2 Sätze erforderlich – 2 sets required
Parkbremse – Parkingbrake



ohne Verschleißanzeige – without wear indicator
 linke Seite – left side
 rechte Seite – right side



Option 1

Option 2

Option 3



Option 1

Option 2

Peugeot

	100 Speedfight 2, X-Race	S2A	01-	AJP	MCB 535	EC	SR	MCB 535	EC	SR
	100 Trekker Road	S2A	99-	AJP	MCB 535	EC	SR	MCS 800		
	100 Vivacity	S2A	99-	AJP	MCB 535	EC	SR	MCS 800		
	100 Vivacity	S2A	99-	Hengtong	MCB 519	EC	SR	MCS 800		
LXR	125	LH	10-		MCB 684	EC		MCB 800	SRM	
SV	125	F121	91-92		MCB 650			MCS 800		
	125 Active		13-		MCB 744	SRM	EC	MCB 700	SRM	EC
SV	125 C Executive	F121	96-		MCB 665	EC		MCS 800		
	125 CityStar		11-		MCB 684	EC		MCB 700	EC	
	125 Django Heritage		14-		MCB 598	SRM				
	125 Elyseo	G2A	00-		MCB 734	EC		MCB 735	EC	
	125 Elyseo	G2A	98-99	AJP	MCB 535	EC		MCS 831		
	125 Elystar	H2	03-		MCB 734	EC		MCB 735	EC	
	125 Geopolis Premium	N2	06-		MCB 734	EC		MCB 735	EC	
	125 Jet-Force Compressor	A2	03-		MCB 734	EC		MCB 735	EC	
	125 Looxor	P2A	03-		MCB 726	SRM		MCB 535	EC	
	125 Ludix		04-	AJP	MCB 535	EC	SR	MCS 800		
	125 New Vivacity	V2	10-		MCB 582	SRM	EC	MCB 700	EC	
	125 Satelis	J2	04-05	AJP	MCB 535	EC		MCB 735	EC	
	125 Satelis	J2	06-	AJP	MCB 734	EC		MCB 735	EC	
	125 Satelis ABS	J2	04-	Nissin	MCB 598	SRM		MCB 735	EC	
	125 Satelis Sport GT	J2	11-	Nissin	MCB 582	SRM	EC	MCB 582	SRM	EC
	125 Sum-Up		08-		MCB 510			MCS 953		
	125 Tweet		10-		MCB 684	EC		MCS 953		
	125 Tweet, RS		10-		MCB 684	EC		MCB 695	EC	
	150 Django Heritage		14-		MCB 598	SRM				
	150 Elyseo	G2A	00-		MCB 734	EC		MCB 735	EC	
	150 Elystar	H2	03-		MCB 734	EC		MCB 735	EC	
	150 Looxor		03-		MCB 726	SRM		MCB 535	EC	SR
	150 Tweet		10-		MCB 684	EC		MCS 953		
	150 Tweet, RS		10-		MCB 684	EC		MCB 695	EC	
LXR	200	LH	10-		MCB 734	EC		MCB 821	EC	
	250 Geopolis	N2	06-	Nissin	MCB 582 SRM			MCB 582 SRM		
	250 Geopolis, ABS	N2	06-	AJP	MCB 734	EC		MCB 735	EC	
	250 Satelis	J2	06-	Nissin	MCB 582 SRM			MCB 582 SRM		
	250 Satelis, ABS	J2	06-	AJP	MCB 734	EC		MCB 735	EC	
	300 Geopolis	N2	10-	Nissin	MCB 582 SRM			MCB 582 SRM		
	300 Geopolis GT	N2	14-	Nissin	MCB 598 SRM			MCB 582 SRM		
	300 Geostyle		11-12	Nissin	MCB 582 SRM			MCB 582 SRM		
	300 Satelis	J2	13-	Nissin	MCB 582 SRM			MCB 582 SRM		
	400 Geopolis	N2	07-	Nissin	MCB 582 SRM			MCB 582 SRM		
	400 Geopolis GT	N2	14-	Nissin	MCB 598 SRM			MCB 582 SRM		
	400 Geopolis RS	N2	08-	Nissin	MCB 598 SRM			MCB 735	EC	
	400 Geopolis, ABS	N2	07-	AJP	MCB 734	EC		MCB 735	EC	
	400 Metropolis		15-		MCB 874 SRM			MCB 874 SRM		
	400 Satelis	J2	06-	Nissin	MCB 598 SRM			MCB 582 SRM		
	400 Satelis i	J2	14-	Nissin	MCB 598 SRM			MCB 582 SRM		
	500 Geopolis	N2	09-	Nissin	MCB 598 SRM			MCB 582 SRM		
	500 Satelis, ABS	J2	06-	Nissin	MCB 736			MCB 735	EC	

PGO

	25 Galaxy		92-		MCB 519	EC	SR	MCS 990		
PMX	50	PM50	98-		MCB 590	EC		MCS 990		
	50 Big Max R	PM	94-06		MCB 590	EC		MCS 990		
	50 Big Max S, Naked		03-		MCB 684	EC		MCS 990		
	50 Bugrider		06-		MCB 807			MCB 510		
	50 Comet		91-95		MCB 519	EC	SR	MCS 990		
	50 Galaxy		92-		MCB 519	EC	SR	MCS 990		
	50 G-Max		05-		MCB 684	EC		MCS 990		
	50 Hot		98-		MCB 590	EC		MCS 990		
	50 Libra		09-		MCB 684	EC				
	50 Liger RS		08-		MCB 684	EC		MCS 990		
	50 Mega		96-		MCB 590	EC		MCS 990		
PMX	50 Naked	PM	01-		MCB 684	EC		MCS 990		
	50 Rodoshow	PE	01-		MCB 644	EC		MCS 990		
	50 Sport		94-		MCB 590	EC		MCS 990		



Option 1

Option 2

Option 3



Option 1

Option 2

PGO

	50 Star		90-		MCS 800				MCS 813		
	50 Tornado		96-		MCB 590	EC			MCS 990		
	50 TR3		02-		MCB 684	EC					
	50 T-Rex	CP	99-		MCB 684	EC			MCS 990		
	50 X-Rider		03-						MCB 519 SI	EC	
	80 Big Max		94-		MCB 590	EC			MCS 990		
	80 Star		90-		MCS 800				MCS 813		
	90 Big Max	PS90	97-		MCB 590	EC			MCS 990		
	90 Galaxy		92-		MCB 519	EC	SR		MCS 990		
	90 Sport		94-		MCB 590	EC			MCS 990		
	90 Tornado		96-		MCB 590	EC			MCS 990		
PMX	110		00-		MCB 684	EC			MCS 990		
	125 G-Max		05-		MCB 684	EC			MCB 663	EC	
	125 Libra EFI		09-		MCB 684	EC					
	125 Ligerio		06-		MCB 684	EC			MCS 921		
	125 Tornado		96-		MCB 590	EC			MCS 990		
	125 T-Rex 2 T	CP0	99-02		MCB 684	EC			MCS 990		
	125 T-Rex 4 T	CP1	00-		MCB 684	EC			MCS 855		
	125 X-Hot EFI		10-		MCB 684	EC					
	125 X-Rider		03-						MCB 519 SI	EC	
	150 Bugrider		05-		* MCB 807				MCB 510	SI	
	150 Bugxter		05-		* MCB 807				MCB 510		
	150 G-Max		05-		MCB 684	EC			MCB 663	EC	
	150 Libra EFI		09-		MCB 684	EC					
	150 T-Rex 4 T	CP2	00-		MCB 684	EC			MCS 855		
	150 X-Hot EFI		10-		MCB 684	EC					
	150 X-Rider		03-						MCB 519 SI	EC	
	200 Bugrider		07-		* MCB 807				MCB 805 SI		
	250 Bugrider		05-		* MCB 807				MCB 805 SI		
	250 G-Max		06-08		MCB 540				MCB 663		
	500 Bug		08-		MCB 836 SI				MCB 760 SI		
	500 Bug		08-						MCB 668 SI		
BR	500 Racer		07-		MCB 836 SI				MCB 760 SI		

Piaggio

	50 Diesis	C34	01-05		MCB 535	EC	SR		MCS 984		
	50 Fly		05-		MCB 744	EC	SRM		MCS 994		
	50 Free		93-95						MCS 985		
	50 Free	FCS	96-		MCB 696	EC	SR		MCS 989		
	50 Liberty 2T	C15	97-08		MCB 827	EC	SRM		MCS 994		
	50 Liberty 2T, 4T		09-		MCB 744	EC	SRM		MCS 994		
	50 Liberty 4T	M22	00-08		MCB 827	EC	SRM		MCS 994		
	50 Liberty Electrico		11-		MCB 827	EC	SRM		MCS 994		
	50 Liberty S		07-08		MCB 827	EC	SRM		MCS 994		
	50 N				MCS 981				MCS 986		
	50 Primavera		14-	Vespa	MCB 744	EC	SRM				
	50 Quartz	NSP	92-		MCB 651	EC			MCS 991		
	50 Storm		94-95		MCB 696	EC	SR		MCS 800		
	50 Storm	TPH	96-		MCB 688	EC			MCS 800		
	50 Zip Disco		96-		MCB 827	EC	SRM		MCS 989		
	50 Zip Fast Rider	SSL	93-95		MCB 696	EC	SR		MCS 991		
	50 Zip Fast Rider	SSL	96-		MCB 827	EC	SRM		MCS 984		
	50 Zip II 4T	M25	00-		MCB 827	EC	SRM		MCS 984		
	50 Zip II Cat. DT	C25	01-		MCB 688	EC			MCS 984		
	50 Zip Sport Production	SSL	96-		MCB 827	EC	SRM		MCS 984		
	50 Zip, Zip + Zip	BMZ	92-		MCS 985				MCS 800		
APE	50		80-05		MCS 981						
ET2	50		97-01	Vespa	MCB 827	EC	SRM		MCS 984		
ET2	50 2T, AC, Euro 2		02-	Vespa	MCB 827	EC	SRM		MCS 984		
ET4	50 4T		00-04	Vespa	MCB 827	EC	SRM		MCS 984		
LX	50 2T / 4T	C38	05-	Vespa	MCB 827	EC	SRM		MCS 984		
LXV	50	C38	07-	Vespa	MCB 827	EC	SRM		MCS 984		
NRG	50	SAL1T	94-95		MCB 696	EC	SR		MCS 991		



* 2 Sätze erforderlich – 2 sets required
Parkbremse – Parkingbrake



ohne Verschleißanzeige – without wear indicator
linke Seite – left side
rechte Seite – right side



Option 1

Option 2

Option 3



Option 1

Option 2

Piaggio

NRG	50 LC DD	C04	98-00		MCB 696	EC	SR		MCB 827	EC	
NRG	50 LC DT	SAL1T	96-99		MCB 696	EC	SR		MCS 989		
NRG	50 mc2	C18	96-97		MCB 696	EC	SR		MCS 989		
NRG	50 mc2 DD	C21	98-01		MCB 696	EC	SR		MCB 827	EC	
NRG	50 mc3 DD (LC)	C32	01-		MCB 696	EC	SR		MCB 827	EC	
NRG	50 mc3 DT (AC)	C21	01-		MCB 696	EC	SR		MCS 984		
NRG	50 mc3 Purejet	C32	02-		MCB 519	EC	SR		MCB 827	EC	
NRG	50 Power DD, DT	C45	05-		MCB 519	EC	SR		MCB 695	EC	SR
NRG	50 Power Purejet	C45	05-		MCB 519	EC	SR		MCB 695	EC	SR
NRG	50 Silver Bullett		10-		MCB 519	EC	SR		MCB 695	EC	SR
NTT	50		96-		MCB 696	EC	SR		MCS 989		
PK	50 S, XL		82-90	Vespa	MCS 981				MCS 980		
PK	50 XL2		90-97	Vespa	MCS 980				MCS 980		
RST	50 Sfera	NSL	91-95		MCB 688	EC			MCS 989		
RST	50 Sfera	C01	96-	Hengtong	MCB 651	EC			MCS 989		
S	50 , Sport	C38	07-	Vespa	MCB 827	EC	SRM		MCS 984		
TPH	50 2 T		11-		MCB 744	SRM	EC		MCS 994		
TPH	50 Thyhoon	TPH	00-		MCB 696	EC	SR		MCS 984		
TPH	50 Thyhoon	TEC	93-99		MCB 696	EC	SR		MCS 989		
TPH	50 Thyhoon Catalyzed	C19	02-		MCB 696	EC	SR		MCS 984		
	80 Skipper		94-98		MCB 651	EC			MCS 984		
PK	80 alle Modelle	Vespa	83-88		MCS 981				MCS 980		
PX	80 E		84-96		MCS 980				MCS 980		
RST	80 Sfera	NSL 80	11/94-		MCS 987				MCS 991		
TPH	80 Typhoon	TEC 80	93-95		MCB 696	EC	SR		MCS 991		
TPH	80 Typhoon	TEC 80	96-		MCB 688	EC			MCS 989		
	100 Fly	M53	06-		MCB 695	EC	SR		MCS 994		
	100 Zip	M53	06-		MCB 695	EC	SR		MCS 994		
	125 946		14-	Vespa	MCB 744	EC	SRM				
	125 Beverly	M28	02-09		MCB 744	SRM	EC		MCB 744	SRM	EC
	125 Beverly		11-		MCB 744	SRM	EC		MCB 771	SRM	
	125 Carnaby	M60	07-09		MCB 744	SRM	EC		MCB 744	SRM	EC
	125 Cosa	Cosa-9	89-		MCS 982				MCS 983		
	125 Fly	M42	05-		MCB 744	SRM	EC		MCS 994		
	125 Hexagon 2T	EX	96-97		MCB 651				MCS 984		
	125 Hexagon 4T	M20	02-03		MCB 744	SRM	EC		MCB 727	SRM	
	125 Hexagon LX 2T	M05	98-99		MCB 664	SRM	EC		MCS 994		
	125 Hexagon LX 4T	M15	98-99		MCB 664	SRM	EC		MCS 994		
	125 MP3 RL/LT i.e.	M47	07-						MCB 832 P		
	125 MP3 RL/LT i.e.	M47	07-		MCB 827	EC	SRM		MCB 782	SRM	
	125 Primavera		14-	Vespa	MCB 744	EC	SRM		MCS 994		
	125 New Fly i.e.		12-		MCB 744	SRM	EC		MCB 733	SRM	
	125 Primavera				MCS 981						
	125 Sfera	M01	6/95-		MCB 827	EC	SRM		MCS 984		
	125 XEvo		08-		MCB 744	SRM	EC		MCB 771	SRM	
	125 Zip II 4T	M25	00-		MCB 827	EC	SRM		MCS 984		
ET4	125	M19	00-		MCB 827	EC	SRM				
ET4	125	M04	96-99		MCB 827	EC	SRM		MCS 984		
GT	125 Granturismo	M31	04-06	Vespa	MCB 744	SRM	EC		MCB 727	SRM	
GTS	125 , Super/ Sport	M31	07-	Vespa	MCB 744	SRM	EC		MCB 727	SRM	
GTV	125	M31	07-09	Vespa	MCB 744	SRM	EC		MCB 746	SRM	
GTX	125 Super Hexagon	M20	00	Grimeca	MCB 664	SRM	EC		MCB 727	SRM	
GTX	125 Super Hexagon	M20	00-03	Hengtong	MCB 744	SRM	EC		MCB 727	SRM	
LE	125 Liberty	M22	98-08		MCB 827	EC	SRM		MCS 994		
LE	125 Liberty, 4T	M11	09-		MCB 827	EC	SRM		MCS 994		
LE	125 i.e. 3V	M73	14-	Hengtong	MCB 744	SRM	EC		MCS 994		
LX	125 4 T		05-	Vespa	MCB 827	EC	SRM		MCS 984		
LXV	125		08-	Vespa	MCB 827	EC	SRM		MCS 984		
PK	125		81-00	Vespa	MCS 980				MCS 980		
PX	125	M09	98-	Vespa	MCB 651	EC			MCS 980		
S	125 , Sport		07-	Vespa	MCB 827	EC	SRM		MCS 984		
SKR	125 Skipper 2T	CSM	94-97		MCB 651	EC			MCS 984		
SKR	125 Skipper LX 2T	CSM	98-99		MCB 664	SRM	EC		MCS 994		
SKR	125 Skipper ST 4T	M21	00-04	Grimeca	MCB 664	SRM	EC		MCS 994		
SKR	125 Skipper ST 4T	M21	00-04	Hengtong	MCB 744	SRM	EC		MCS 994		



Option 1

Option 2

Option 3



Option 1

Option 2

Piaggio

TPH	125 Typhoon	TEC	93-95		MCB 696	EC	SR		MCS 991		
TPH	125 Typhoon	M02	96-01		MCB 696	EC			MCS 984		
TPH	125 Typhoon Catalyzed	M02	02-		MCB 696	EC	SR		MCB 696	EC	SR
TPH	125 Typhoon 4T	C50	11-		MCB 744	SRM	EC		MCS 994		
X7	125 , Evo i.e.	M62	08-		MCB 744	SRM	EC		MCB 771	SRM	
X8	125 4 T	M36	04-06		MCB 744	SRM	EC		MCB 700	SRM	EC
X8	125 Street	M36	05-		MCB 744	SRM	EC		MCB 782	SRM	
X9	125	M23	01-03		* MCB 700	SRM	EC		MCB 700	SRM	EC
X9	125		04-		☑ MCB 744	SRM	EC		MCB 700	SRM	EC
X9	125		04-		☑ MCB 771	SRM					
X9	125 Evolution		06-		☑ MCB 744	SRM	EC		MCB 782	SRM	
X9	125 Evolution		06-		☑ MCB 771	SRM					
X10	125 Executive		13-		☑ MCB 744	SRM			MCB 782	SRM	
X10	125 Executive		13-		☑ MCB 771	SRM					
	150 Beverly		04-06	Grimeca	MCB 664	SRM	EC		MCB 664	SRM	EC
	150 Beverly		04-06	Hengtong	MCB 744	SRM	EC		MCB 744	SRM	EC
	150 Cosa	Cosa-9	89-		MCS 982				MCS 983		
	150 Fly		05-		MCB 744	SRM	EC		MCS 994		
	150 Hexagon	EX	94-95		MCB 696	EC	SR		MCS 984		
	150 Hexagon	EX	96-97		MCB 688	EC			MCS 984		
	150 Liberty	M22	08-		MCB 827	SRM	EC		MCS 994		
	150 Primavera		14-	Vespa	MCB 744	EC	SRM				
	150 Skipper	CVM	94-98		MCB 651	EC			MCS 984		
GTX	150 Super Hexagon		00-	Grimeca	MCB 734	EC			MCB 727 SRM		
GTX	150 Super Hexagon		01-	Hengtong	MCB 744 SRM	EC			MCB 727 SRM		
PX	150		98-	Vespa	MCB 651	EC			MCS 980		
S	150 , Sport	M68	07-	Vespa	MCB 827	SRM	EC		MCS 984		
SKR	150	CSM	94-		MCB 696	EC	SR		MCS 984		
X8	150 Street	M36	05-		MCB 744	SRM	EC		MCB 782	SRM	
	180 Beverly GT	M28	02-07	Grimeca	MCB 734	EC			MCB 734	EC	
GTX	180 Super Hexagon	M20	00-	Grimeca	MCB 664 SRM				MCB 727 SRM		
GTX	180 Super Hexagon	M20	00-	Hengtong	MCB 744 SRM				MCB 727 SRM		
LTX	180 Hexagon	M05	98-		MCB 664 SRM	EC			MCS 994		
X9	180		00-02		MCB 700 SRM				MCB 700 SRM		
	200 Beverly GT	M28	02-07	Hengtong	MCB 744 SRM				MCB 744 SRM		
	200 Carnaby		08-		MCB 744 SRM				MCB 744 SRM		
	200 Cosa	Cosa-9	89-		MCS 982				MCS 983		
	200 Liberty	M22	98-08		MCB 827	SRM	EC		MCS 994		
GT	200 Granturismo (Vespa)	M31	03-06	Grimeca	MCB 734				MCB 727 SRM		
GT	200 Granturismo (Vespa)	M31	03-06	Hengtong	MCB 744 SRM				MCB 727 SRM		
PX	200	P200E	78-97	Vespa	MCS 980				MCS 980		
PX	200	P200E	98-07	Vespa	MCB 651	EC			MCS 980		
X8	200	M36	04		MCB 744 SRM				MCB 700 SRM		
X8	200	M36	05-		MCB 744 SRM				MCB 782 SRM		
X9	200		03-		MCB 700 SRM				MCB 700 SRM		
	250 Beverly	M28	04-08		MCB 744 SRM				MCB 744 SRM		
	250 Carnaby	M60	08-		MCB 744 SRM				MCB 744 SRM		
	250 MP3 RL/LT i.e.	M47	06-09		MCB 827 SRM				MCB 771 SRM		
	250 MP3 RL/LT i.e.	M47	06-09		Ⓟ				MCB 832 P		
BV	250		06-		MCB 744 SRM				MCB 744 SRM		
GT	250 Hexagon	M14	98-00		MCB 664 SRM				MCS 994		
GTS	250 i.e. (Vespa)	M45	06-11		MCB 744 SRM				MCB 782 SRM		
GTS	250 i.e. ABS (Vespa)	M45	06-11		MCB 744 SRM				MCB 782 SRM		
GTV	250 i.e. (Vespa)	M45	07-09		MCB 744 SRM				MCB 782 SRM		
GTX	250 Super Hexagon	M20	01-		MCB 664 SRM				MCB 727 SRM		
X7	250 i.e.	M62	08-		MCB 744 SRM				MCB 771 SRM		
X8	250 , i.e.	M36	05-07		MCB 744 SRM				MCB 782 SRM		
X9	250	M27	00-04		* MCB 700 SRM				MCB 700 SRM		
X9	250 Evolution		05-		☑ MCB 744 SRM				MCB 782 SRM		
X9	250 Evolution		05-		☑ MCB 771 SRM						
	250 XEvo	M36	08-		MCB 744 SRM				MCB 771 SRM		
GTS	300 Super, Supersport	M45	09-	Vespa	MCB 744 SRM				MCB 727 SRM		
GTV	300 i.e.	M45	10-	Vespa	MCB 744 SRM				MCB 782 SRM		



* 2 Sätze erforderlich – 2 sets required
 Parkbremse – Parkingbrake



ohne Verschleißanzeige – without wear indicator
 linke Seite – left side
 rechte Seite – right side



Option 1

Option 2

Option 3



Option 1

Option 2

Piaggio

X7	300 i.e. Evo	M62	10-		MCB 744 SRM			MCB 771 SRM		
	300 Beverly		07-		MCB 744 SRM			MCB 771 SRM		
	300 Beverly i.e.		10-		MCB 744 SRM			MCB 771 SRM		
	300 Carnaby Cruiser	M60	08-11		MCB 744 SRM			MCB 744 SRM		
	300 Carnaby i.e.	M60	12-		MCB 744 SRM			MCB 744 SRM		
	300 MP3 LT	M71	10-		MCB 827 SRM			MCB 771 SRM		
	300 MP3 LT	M71	10-	P				MCB 832 P		
X10	350 Executive		13-		MCB 744 SRM			MCB 771 SRM		
X10	350 Executive		13-		MCB 771 SRM					
X10	350 Executive			P				MCB 832 P		
	350 Beverly Sport Touring i.e.		12-		MCB 726 SRM			MCB 771 SRM		
	350 Beverly Sport Touring i.e. ABS		12-		MCB 726 SRM			MCB 771 SRM		
X8	400 Evolution i.e.	M52	06-08		MCB 744 SRM			MCB 782 SRM		
X8	400 Evolution i.e.	M52	06-08		MCB 771 SRM					
	400 Beverly	M34	06-10		MCB 648 SRM			MCB 744 SRM		
	400 Beverly Tourer i.e.	M34	08-09		MCB 700 SRM			MCB 700 SRM		
	400 MP3 RL/ LT i.e.	M59	07-		MCB 827 SRM			MCB 744 SRM		
	400 MP3 RL/ LT i.e.	M59	07-	P				MCB 832 P		
	400 XEvo	M52	08-		MCB 744 SRM			MCB 744 SRM		
	400 XEvo	M52	08-		MCB 771 SRM					
BV	500		06-		MCB 700 SRM			MCB 700 SRM		
X10	500 i		12-		MCB 744 SRM			MCB 771 SRM		
X10	500 i		12-		MCB 771 SRM					
X9	500 Evolution	M27	03-06	*	MCB 648 SRM			MCB 700 SRM		
X9	500 Evolution ABS	M27	03-06	*	MCB 648 SRM			MCB 700 SRM		
X9	500 i.e.	M27	07	*	MCB 648 SRM			MCB 700 SRM		
X9	500 SL	M27	01-02	*	MCB 700 SRM			MCB 700 SRM		
	500 Beverly	M34	02-06	*	MCB 700 SRM			MCB 700 SRM		
	500 Beverly i.e., Cruiser i.e.	M34	07-	*	MCB 700 SRM			MCB 700 SRM		
	500 MP3 EFI, LT i.e.	M64	09-		MCB 827 SRM			MCB 771 SRM		
	500 MP3 EFI, LT i.e.	M64	09-	P				MCB 832 P		

Polaris

	50 Outlaw		08-		MCS 832			MCS 843		
	50 Predator		04-		MCS 832			MCS 843		
	50 Scrambler		01-03		MCS 832			MCS 843		
	90 Outlaw		07-11					MCS 843		
	90 Predator		03-04		MCS 832			MCS 843		
	90 Scrambler		01-03		MCS 832			MCS 843		
	90 Sportsman		01-		MCS 832			MCS 843		
	170 Ranger RZR		09-	*	MCB 868 SI			MCB 869 SI		
	200 Phoenix		10-	*	MCB 868 SI			MCB 523 SI		
	250 Trail Blazer		94-98	*	MCB 761 SI			MCB 668 SI		
	250 Trail Blazer		99-	*	MCB 761 SI			MCB 762 SI		
	250 Trail Boss			*	MCB 619			MCB 668 SI		
	300 Hawkeye		07-09	*	MCB 761 SI			MCB 761 SI		
	300 Sportsman		08-10	*	MCB 761 SI			MCB 761 SI		
	325 Magnum 2x4,4x4		00-02	*	MCB 761 SI			MCB 762 SI		
	325 Trail Boss		00-	*	MCB 761 SI			MCB 762 SI		
	330 ATP		04-	*	MCB 761 SI			MCB 761 SI		
	330 Magnum 2x4,4x4		03-	*	MCB 761 SI					
	330 Trail Boss, Trail Blazer		03-	*	MCB 761 SI			MCB 762 SI		
	400 Ranger HO		10-	*	MCB 853 SI			MCB 854 SI		
	400 Scrambler 2x4,4x4		00-	*	MCB 761 SI			MCB 762 SI		
	400 Sportsman		01-02	*	MCB 761 SI			MCB 762 SI		
	400 Sportsman		03-05	*	MCB 761 SI			MCB 798 SI		
	400 Sportsman HO 4x4		08-10	*	MCB 761 SI			MCB 761 SI		
	400 Sportsman HO 4x4		11-	*	MCB 761 SI			MCB 855 SI		
	400 Xpedition 4x4		00-	*	MCB 761 SI			MCB 762 SI		
	400 Xplorer L 4x4		00-	*	MCB 761 SI			MCB 762 SI		
	450 Outlaw S, MXR		08-	*	MCB 854 SI			MCB 619		
	450 Sportsman		06-07	*	MCB 761 SI			MCB 798 SI		
ATP	500		04-	*	MCB 761 SI			MCB 761 SI		
	500 Magnum 2x4,4x4 HDS		02-	*	MCB 761 SI			MCB 798 SI		



Option 1

Option 2

Option 3



Option 1

Option 2

Polaris

500 Magnum 4x4	00-01	*	MCB 761 SI			MCB 762 SI		
500 Outlaw	06-07	*	MCB 761 SI			MCB 761 SI		
500 Predator	03-07	*	MCB 761 SI			MCB 761 SI		
500 Ranger 2x4/4x4	06-07	*	MCB 854 SI			MCB 854 SI		
500 Ranger 2x4/4x4 EFI	08-10	*	MCB 853 SI			MCB 854 SI		
500 Ranger 4x4 EFI	11-	*	MCB 854 SI			MCB 854 SI		
500 Ranger 6x6	04-05	*	MCB 761 SI					
500 Ranger Crew	11-	*	MCB 853 SI			MCB 854 SI		
500 Ranger HO 4x4 EFI	09-11	*	MCB 853 SI			MCB 854 SI		
500 Revolver	06-	*	MCB 619			MCB 619		
500 Scrambler 2x4	01-02	*	MCB 761 SI			MCB 762 SI		
500 Scrambler 2x4	07-08	*	MCB 761 SI			MCB 798 SI		
500 Scrambler 4x4	97	*	MCB 761 SI			MCB 668 SI		
500 Scrambler 4x4	05-	*	MCB 761 SI			MCB 798 SI		
500 Scrambler 4x4	98-04	*	MCB 761 SI			MCB 762 SI		
500 Sportsman 4x4	96-	*	MCB 761 SI			MCB 668 SI		
500 Sportsman 6x6	00-08	*	MCB 761 SI					
500 Sportsman EFI Quad HO	08-	*	MCB 619			MCB 855 SI		
500 Sportsman HO/EFI	03-08	*	MCB 619			MCB 798 SI		
500 Sportsman Touring HO	09-11	*	MCB 619			MCB 855 SI		
500 Sportsman X2 EFI	07-09	*	MCB 761 SI			MCB 761 SI		
500 Sportsman XP	09	*	MCB 855 SI			MCB 855 SI		
525 Outlaw S, IRS	07-	*	MCB 854 SI			MCB 761 SI		
550 Sportsman X2, XP, XP EPS	09-	*	MCB 855 SI			MCB 855 SI		
550 Sportsman, EPS, Touring EPS	10-	*	MCB 855 SI			MCB 855 SI		
570 Ranger RZR EFI	12-	*	MCB 854 SI			MCB 619		
600 Sportsman 4x4	03-05	*	MCB 619			MCB 798 SI		
700 MVRS 4x4	08-	*	MCB 853 SI			MCB 853 SI		
700 Ranger 4x4 EFI	07	*	MCB 857 SI			MCB 857 SI		
700 Ranger 4x4 EFI	09	*	MCB 853 SI			MCB 857 SI		
700 Ranger 6x4 EFI	08	*	MCB 853 SI			MCB 857 SI		
700 Ranger 6x6 EFI	06-09	*	MCB 857 SI			MCB 857 SI		
700 Ranger Crew 4x4 EFI	09	*	MCB 853 SI			MCB 857 SI		
700 Ranger XP 4x4	06-08	*	MCB 857 SI			MCB 857 SI		
700 Sportsman 4x4	02-06	*	MCB 619			MCB 798 SI		
700 Sportsman EFI, MV	05-07	*	MCB 761 SI			MCB 798 SI		
700 X 2	08	*	MCB 761 SI			MCB 761 SI		
800 Ranger Crew	10-	*	MCB 853 SI			MCB 857 SI		
800 Ranger EV, HD, XP, 6x6	10-11	*	MCB 853 SI			MCB 857 SI		
800 Ranger RZR, S EFI	08-	*	MCB 854 SI			MCB 619		
800 Ranger RZR-4, EPS	10-	*	MCB 853 SI			MCB 857 SI		
800 Sportsman 6x6 Big Boss	09-	*	MCB 761 SI			MCB 761 SI		
800 Sportsman EFI/HO	05-08	*	MCB 619			MCB 798 SI		
800 Sportsman EFI/HO	09-	*	MCB 619			MCB 855 SI		
800 Sportsman Touring, X 2 EFI	07-	*	MCB 761 SI			MCB 761 SI		
850 Scrambler HO/ HO EPS	13-	*	MCB 855 SI			MCB 855 SI		
850 Sportsman Touring EPS	10-	*	MCB 855 SI			MCB 855 SI		
850 Sportsman Touring HO EPS	13-	*	MCB 855 SI			MCB 855 SI		
850 Sportsman X2, XP, XP EPS	09-	*	MCB 855 SI			MCB 855 SI		
900 Ranger RZR XP	11-	*	MCB 853 SI			MCB 857 SI		

Puch

50 Cobra 6, GT, GTL	80-		MCB 508					
50 Cobra M 82	-85		MCB 596					
50 Monza 4, SL, GSL	80-		MCB 508					
50 Monza Lujo	-85		MCB 596					
50 Ranger	86-		MCB 508					

Qingqi

QM	50 QT		MCB 590	EC				
----	-------	--	---------	----	--	--	--	--

Quadzilla

WK	50	06-	MCS 838			MCS 838		
R	50	03-06	MCS 838			MCS 968		



* 2 Sätze erforderlich – 2 sets required
Parkbremse – Parkingbrake



ohne Verschleißanzeige – without wear indicator



linke Seite – left side



rechte Seite – right side



Option 1

Option 2

Option 3



Option 1

Option 2

Quadzilla

WK	70		06-							MCS 838						MCS 838		
X	100 E		06-							MCS 962						MCB 523 SI		
R	100		06-09							MCS 838						MCS 968		
WK	110		06-							MCB 590	EC							
WK	125		06-							MCB 590	EC							
WK	140		06-							MCB 844						MCB 846		
	170 E Stinger		06-							MCS 962						MCB 582 SI		
BR	200 E Bugrider		07-						*	MCB 807						MCB 805 SI		
XRV	250 E		06-						*	MCB 807						MCB 805 SI		
	250 E Stinger		06-						*	MCB 519 SI	EC					MCB 523 SI		
RL	300 Buggie		07-						*	MCB 807						MCB 805 SI		
XLC	300 E, LE		07-						*	MCB 523 SI						MCB 523 SI		
	500 4x4		06-													MCB 762 SI		
RL	500 Buggie		08-						*	MCB 617						MCB 617		
	500 e 4x4		07-													MCB 756 SI		

REX

	50 Bergamo		12							MCB 519	EC					MCB 519	EC	
	50 Capriolo	QM50QT-2	07-							MCB 765						MCS 800		
	50 E-Rex, RS Classic		11-							MCB 822						MCB 663	EC	
	50 Escape		03-							MCB 519	EC	SR						
	50 Flash		96-							MCB 590	EC					MCS 800		
	50 Imola		13-							MCB 822						MCB 663	EC	
	50 Monaco		12-							MCB 615	EC	SRM				MCB 535	EC	
	50 Monza 50 Urban, Race		11-							MCB 822						MCS 800		
	50 Palermo		12-							MCB 519	EC							
	50 Rex		98-							MCB 519	EC	SR						
	50 RS250		04-							Qingqi/SMC	EC					MCS 800		
	50 RS450		04-							Qingqi/Shenke						MCS 800		
	50 RS460									Shenke								
	50 RS500									Qingqi						MCS 800		
	50 RS600									Qingqi								
	50 RS700		08-							Qingqi	EC					MCS 800		
	50 RS900									Qingqi								
	125 Capriolo									Qingqi	EC							
	125 Imola 50 Race		11-							MCB 822						MCB 663	EC	SRM
	125 Monaco 50 Race		11-							MCB 615	EC	SRM				MCB 535	EC	
	125 Remy		98-							MCB 590	EC							
	125 RS1000		10-							Jonway						MCB 663	EC	SRM
	125 RS1100		10-							Jonway						MCB 663	EC	SRM
	125 Silverstreet		99-							MCB 519	EC	SR						
	125 Speedy									Qingqi	EC							
RS	125									Qingqi						MCB 765		
SC	125		08-							Qingqi	EC					MCB 539		
	150 Quad	SMC	10-						*	MCB 582	SI							
	250 Quad	SMC	10-						*	MCB 582	SI							

Rieju

	alle Modelle		85-							MCB 535	EC					MCB 535	EC	
RS1	50 Castrol	RSE	01-							MCB 664						MCB 535	EC	
RS1	50 Evolution	VTPRSE	96-00							MCB 535	EC					MCB 535	EC	
RS2	50 Matrix		03-							MCB 796						MCB 535	EC	
MRX	50 Pro		05-							MCB 629						MCB 535	EC	
RS3	50 Pro		12-							MCB 780	SV					MCB 535	EC	
MRX	50 Racing	MRX	02-							MCB 535	EC					MCB 535	EC	
RR	50 Supermotard	RR	96-							MCB 535	EC					MCB 535	EC	
MRT	50									MCB 765						MCB 765		
NKD	50		04-							MCB 796						MCB 535	EC	
RS3	50		12-							MCB 796						MCB 519	EC	
SMX	50		02-							MCB 629						MCB 535	EC	
SMX	50		02-							AJP						MCB 535	EC	
RS2	125 NKD		06-							MCB 759						MCB 519	SI	EC
RS2	125 Pro		08-							MCB 779						MCB 519	SI	EC
	125 Tango, Tango Pro		06-							MCB 700						MCB 535	EC	
MRX	125	MR4T	02-							MCB 629						MCB 535	EC	



Option 1

Option 2

Option 3



Option 1

Option 2

Rieju

MRX	125	MR4T	02-	AJP	MCB 535				MCB 535	EC	
SMX	125	MR4T	02-		MCB 629				MCB 535	EC	
SMX	125	MR4T	02-	AJP	MCB 535				MCB 535	EC	
	250 Tango		08-		MCB 700	EC			MCB 535	EC	
MRX	450		08-		MCB 648	SI	RSI	EC	MCB 743 SI	RSI	EC

Royal Enfield

	500 Bullet		05-		MCB 689	EC					
	500 Clubman EFI		09-		MCB 689	EC					
	500 Electra EFI		09-		MCB 689	EC					
	500 Fury EFI		11-		MCB 689	EC					
	500 Trials EFI		09-		MCB 689	EC					
	500 Woodsman EFI		09-		MCB 689	EC					

Sachs

	50 49er II		08-		MCB 694	EC					
	50 Bee		08-10		MCB 539	EC			MCS 953		
ZX	50 Enduro	693	95-		MCB 664				MCB 657		
	50 Gipsy	FE 053-DE	8/94-		MCB 674	EC	SR		MCS 800		
	50 Limbo		94-		MCB 674	EC	SR		MCS 800		
	50 Mad Ass		04-05		MCB 525	EC			MCB 535	EC	
	50 Mad Ass		06-09		MCB 525	EC			MCB 510		
	50 Raggae		8/94-	Hengtong	MCB 519	EC	SR		MCS 800		
	50 Raggae		8/94-	Grimeca	MCB 674	EC	SR		MCS 800		
SR	50 Samba		93-		MCS 800				MCS 800		
	50 Speedfight		96-		MCB 522				MCS 800		
	50 Speedforce		08		MCB 694	EC					
RS	50 Speedjet		08		MCB 694	EC					
	50 Splinter		8/94-	Grimeca	MCB 674	EC	SR		MCS 800		
	50 Splinter		8/94-	Hengtong	MCB 519	EC	SR		MCS 800		
	50 Squab		96-		MCB 644	EC			MCS 800		
SX-1	50		08-09		MCB 694	EC					
SR	80 Samba	FE 082-DE	11/93-		MCB 665	EC			MCS 800		
	125 Bee		08-10		MCB 539	EC			MCS 953		
	125 Dirty Devil		08		MCB 767				MCB 767		
ZX	125 Enduro	660	97-		MCB 664				MCB 657		
ZX	125 Enduro	660	99-		MCB 557				MCB 657		
ZZ	125 Funbike	660	98		MCB 664				MCB 657		
ZZ	125 Funbike	660	99-		MCB 696				MCB 657		
	125 Husky		97-	Sanyang	MCB 719				MCS 990		
	125 Mad Ass		05		MCB 525	EC			MCB 525	EC	
	125 Mad Ass		06-09		MCB 525	EC			MCB 510		
XTC	125 Racing		08-		MCB 683	SV	SRQ		MCB 510		
XTC	125 Racing	675	99-07		MCB 540	SV	SRQ		MCB 657		
	125 Roadster V2	680	01-		MCB 557				MCS 953		
SR	125 Samba	F 121	6/94-		MCB 665	EC			MCS 800		
RS	125 Speedjet		08		MCB 694	EC					
	125 X-Road		07		MCB 540	SV	SRQ		MCB 510		
	125 X-Road		08-		MCB 683	SV	SRQ		MCB 510		
	650 Roadster V1.6		03-05		* MCB 540	SV	SRQ	CRQ	MCB 539	EC	
	650 Roadster V1.6	830	00-02		* MCB 540				MCB 657		
	800 Roadster V2	835	00-05		* MCB 540				MCS 959		
	800 S-805, B-805		03-04		* MCB 540	SV	SRQ	CRQ	MCB 539	EC	

Sherco

	80 Trials 0.8		01-04		MCB 535	RQ	EC		MCB 767		
	80 Trials 0.8		05-	AJP	MCB 766				MCB 767		
SE	125 4T Enduro 1.25		10-		MCB 734	EC			MCB 735	EC	
SM	125 Black Panther 1.25i		10-		MCB 734	EC			MCB 735	EC	
	125 Trials 1.25		06-10		MCB 766				MCB 767		
	125 Trials 1.25		99-05		MCB 535	RQ	EC		MCB 535	RQ	EC
	200 Trials 2.00		99-05		MCB 535	RQ	EC		MCB 535	RQ	EC
SE	250 4T Enduro 2.5i		08-		MCB 648 SI	RSI	EC		MCB 739 SI	RSI	



* 2 Sätze erforderlich – 2 sets required
Parkbremse – Parkingbrake



ohne Verschleißanzeige – without wear indicator



linke Seite – left side



rechte Seite – right side



Option 1

Option 2

Option 3



Option 1

Option 2

Sherco

SE	250 i, iR Enduro	12-		MCB 648 SI	RSI	EC		MCB 743 SI	RSI	EC
	250 Trials 2.50	06-10		MCB 766				MCB 767		
	250 Trials 2.50	99-05		MCB 535	RQ	EC		MCB 535	RQ	EC
	290 Trials 2.90	06-10		MCB 766				MCB 767		
	290 Trials 2.90	99-05		MCB 535	RQ	EC		MCB 535	RQ	EC
SE	300 4T Enduro 3.0i	10-11		MCB 648 SI	RSI	EC		MCB 739 SI	RSI	
SE	300 i, iR Enduro	12-		MCB 648 SI	RSI	EC		MCB 743 SI	RSI	EC
	320 Trials 3.20	05-		MCB 766				MCB 767		
SE	450 4T Enduro 4.5i	04-11		MCB 648 SI	RSI	EC		MCB 739 SI	RSI	
SE	450 F, F-R	14-		MCB 648 SI	RSI	EC		MCB 743 SI	RSI	EC
SM	450 Black Panther 4.5i	08-	4 ☐	MCB 721 SV	SRQ	CRQ		MCB 739 SI	RSI	
SM	450 F Super Motard 4.5i	07-		MCB 648 SI	RSI	EC		MCB 739 SI	RSI	
SE	450 i R Enduro	12-		MCB 648 SI	RSI	EC		MCB 739 SI	RSI	
SE	510 4T Enduro 5.1i	07-11		MCB 648 SI	RSI	EC		MCB 739 SI	RSI	
SM	510 Black Panther 5.1i	08-	4 ☐	MCB 721 SV	SRQ	CRQ		MCB 739 SI	RSI	
SM	510 F Super Motard 5.1i	07-		MCB 648 SI	RSI	EC		MCB 739 SI	RSI	
SE	510 iR Enduro	12-		MCB 648 SI	RSI	EC		MCB 739 SI	RSI	

Siamoto

	25 Birdie	02-04		MCB 590	EC					
	50 Birdie	02-04		MCB 590	EC					
BD	125			MCB 629						
KD	125			MCB 629						
SX1	125	04-		MCB 734	EC					

Simson

SR	50	95-		MCB 564	SR					
S53	50 alpha C	93-97		MCB 564	SR					
S53	50 beta	93-97		MCB 564	SR					
	50 Habicht	96-		MCB 564	SR					
	50 Sperber	97		MCB 564	SR					
	50 Sperber	MSA50	98-	MCB 578						
	50 Star	SRA50	96-	MCB 564	SR					
	50 Sula City Bird	98-		MCB 522						
	50 Sula Thunder Bird	98-		MCB 522						
S53	70 alpha C	93-97		MCB 564	SR					
S83	70 Beta	93-97		MCB 564	SR					
SR	80	95-		MCB 564	SR					
	100 Sula Thunder Bird	98-		MCB 522						
	125 Schikra	MS125	99-	MCB 673	EC			MCB 578		
	125 SM	1C	01-	MCB 629				MCB 535		EC
	125 Sula Thunder Bird	98-		MCB 522						

Sinnis

QM	50 Falcon	08-		MCB 590	EC			MCS 800		
QM	50 Hawk	08-		MCB 689	EC			MCS 990		
QM	125 Apache	09-	☐	MCB 582	SI	RSI		MCB 510	SI	
QM	125 Apache	09-	()	MCB 582	SI	RSI		MCS 855		
QM	125 Blade	09-		MCB 582	SI	RSI		MCB 510	SI	
	125 Eagle	10-		MCB 510				MCS 953		
	125 Eco City	07-		MCB 510				MCS 800		
QM	125 Matrix, Matrix II	10-		MCB 510				MCS 953		
QM	125 Stealth	08-		☐ MCB 582	SRM			MCB 585	SRM	
QM	125 Stealth	08-		☐ MCB 615	SRM					
QM	125 Vista	08-		MCB 765				MCS 958		

Suzuki

	50 Lido	CS50H	89-		MCS 921			MCS 921		
	50 Lido		91-		MCB 569			MCB 615	EC	
A	50 K		75-		MCS 854			MCS 854		
AH	50 Address	CA1GA	93-95		MCS 921			MCS 921		
AP	50		71-78		MCS 854			MCS 854		
AP	50 S	CA1JA	95-98		MCB 674	EC	SR	MCS 921		
AY	50 Katana	AA	97-02	Grimeca	MCB 674	EC	SR	MCS 921		
AY	50 WR Katana	AA/WVAA	01-06	AJP	MCB 535	EC	SR	MCB 535	EC	SR
AY	50 WR Katana	AA	99-02	Grimeca	MCB 674	EC	SR	MCB 535	EC	SR



Option 1

Option 2

Option 3



Option 1

Option 2

Suzuki

CS	50 Roadie		83-84					MCS 840				MCS 840		
GT	50		77-					MCB 91				MCS 854		
GT	50	GT50	79-					MCB 16				MCS 854		
GT	50 E	GT50E	79-					MCB 16				MCS 854		
GT	50 K	GT50K	79-					MCB 91				MCS 854		
GT	50 KE	GT50K	79-					MCB 16				MCS 854		
JR	50		78-07					MCS 840				MCS 840		
LT	50 ATV MINI		86-02									MCS 840		
LT-A	50 ATV MINI		02-05					MCS 838				MCS 901		
LT-Z	50 ATV MINI		06-12					MCS 838				MCS 901		
RMX	50		00-					MCB 535	EC			MCB 535	EC	
TR	50 Street Magic	AH	97-00					MCB 679	SR			MCS 990		
TS	50 ERK	TS50XK	80-83					MCS 854				MCS 901		
TS	50 K	TS50K	78-79					MCS 854				MCS 854		
UF	50 Estilete	WVBA	00-01					MCB 535	EC SR			MCS 921		
UX	50 Zillion	AT	99-00					MCB 674	EC SR			MCS 921		
ZR	50 K	ZR50K	79-					MCB 16				MCS 854		
RM	60		03-					MCS 857				MCS 857		
RM	65		03-					MCB 714 SI	EC			MCB 561 SI	EC	
AH	80		92-					MCB 519	EC			MCS 921		
CP	80		85-					MCS 921				MCS 921		
GT	80 E,L	GT80	81-83					MCB 523				MCS 854		
LT	80		87-06					MCS 838						
RG	80 Gamma	NC11A	85-87					MCB 556				MCS 855		
RG	80 Gamma	NC11A	88-96					MCB 556				MCS 855		
RM	80		80-81					MCS 901				MCS 901		
RM	80	RC11	83-85					MCS 855				MCS 901		
RM	80		86-88					MCB 522				MCS 963		
RM	80		89-93					MCB 519 SI	EC			MCB 519 SI	EC	
RM	80		94-95					MCB 582 SI	RSI SV			MCB 519 SI	EC	
RM	80	RC12A	96-01					MCB 679 SI	EC			MCB 519 SI	EC	
TS	80 X	SC11A	84-87					MCS 855				MCS 901		
RM	85		02-04					MCB 679 SI	EC			MCB 519 SI	EC	
RM	85		05-					MCB 697 SI	RSI EC			MCB 772 SI	RSI EC	
LT-Z	90 ATV MINI		07-10					MCS 901						
RV	90	RV90	73-77					MCS 854				MCS 854		
AH	100 Adress	CE12A	94-95					MCB 519	EC SR			MCS 990		
RM	100		03-					MCB 697 SI	EC			MCB 561 SI	EC	
TS	100 ER		75-81					MCS 855				MCS 855		
TS	100 ER		82-					MCS 855				MCS 901		
UG	110 Hokuto	AT	98-02					MCB 679	SR			MCS 990		
	110 Adress		15-					MCB 519	EC SR					
	125 Lido Vario	CF41BH	90-					MCB 522				MCS 921		
	125 Vecstar		96-					MCB 679	SR			MCS 921		
AN	125	CF42A	95-00					MCB 679	SR			MCS 921		
DR	125 S	SF42A	82-84					MCS 855				MCS 855		
DR	125 S	SF42A	85-93					MCB 510	SI			MCS 855		
DR	125 S	SF43B	91-93					MCB 510	SI			MCS 855		
DR	125 SE	SF44A	95-00					MCB 510	SI			MCS 855		
DR	125 SM	CS	09-10					MCB 669 SI	RSI EC			MCB 575 SI	RSI EC	
DR-Z	125		04-					MCB 679	SI EC			MCS 901		
EN	125		05-					MCB 582	SV			MCS 855		
FL	125 SD Adress	WVCM	07-09					MCB 663	SRM EC					
GN	125 R	NF41A	94-99					MCB 523				MCS 855		
GP	125	GP125	77-					MCB 513				MCS 855		
GS	125 S, SU	AW	99					MCB 765				MCS 855		
GT	125	GT125	74-77					MCB 16				MCS 855		
GT	125 E	GT125	78-79					MCB 16				MCS 855		
GV	125 Z, E		82-90					MCB 765						
GV	125		05-					MCB 765						
GZ	125 Marauder	AP	98-11					MCB 550				MCS 855		
RG	125 Gamma		85-90					MCB 556				MCS 855		
RG	125 Gamma	NF13	91-					MCB 602	SV			MCB 531	SH	



* 2 Sätze erforderlich – 2 sets required
Parkbremse – Parkingbrake



ohne Verschleißanzeige – without wear indicator



linke Seite – left side



rechte Seite – right side



Option 1

Option 2

Option 3



Option 1

Option 2

Suzuki									
RM	125	RM125	75-80		MCB 855				MCS 855
RM	125		81-83		MCB 855				MCS 915
RM	125	RF12A	84						MCS 915
RM	125		85-86		MCB 550				MCS 915
RM	125	RF13A	87		MCB 582 SI	RSI			MCS 915
RM	125	RF13A	88		MCB 582 SI	RSI			MCB 538 SI
RM	125	RF14A	89-93		MCB 582 SI	RSI			MCB 625 SI
RM	125	RF14A	94-95		MCB 582 SI	RSI			MCB 625 SI
RM	125	RF15A	96-04		MCB 669 SI	RSI	EC		MCB 575 SI
RM	125		05-		MCB 669 SI	RSI	EC		MCB 575 SI
RV	125	RV125	73		MCS 854				MCS 855
RV	125	RV125	74-81		MCS 855				MCS 855
RV	125 Van Van	WVBT	03-		MCB 681	SV			MCS 854
TS	125	TS125	72		MCS 854				MCS 855
TS	125	TS1252	73-81		MCS 855				MCS 855
TS	125		85-89		MCB 510	SI			
TS	125 R		90-96		MCB 582	SI			MCB 625 SI
TU	125 XT	AZ	99		MCB 523	SI			MCS 855
UC	125 Epicuro	AX	99-01		MCB 679	SR			MCS 823
UE	125	WVBH	01-03		MCB 519	EC			MCS 921
UH	125 Burgman	BP	02-06		MCB 648	SRM			MCB 700
UH	125 Burgman	CC	07-		MCB 776	SRM			MCB 724
UX	125 SIXteen	CN	08-12		MCB 776	SRM			MCB 724
VL	125 Intruder	WVA4	02-07		MCB 550				MCS 855
VL	125 Intruder	A4	00-01		MCB 550				MCS 855
	150 Vecstar		96-		MCB 679	SR			MCS 921
AN	150		98-		MCB 679	SR			MCS 921
UE	150 CT	BJ	02-		MCB 519	EC			MCS 823
UH	150 Burgman		04-		MCB 648	SRM			MCB 700
UX	150 SIXteen	CP	08-09		MCB 648	SRM			MCB 700
LT-F	160		91-01		MCS 921				MCS 902
PE	175		78-79		MCS 855				MCS 855
PE	175		80-81		MCS 855				
PE	175		82-83						
GT	185	GT185	73-75		MCB 16				MCS 855
GT	185 E	GT185	78-		MCB 16				MCS 855
TS	185	TS185	73-		MCS 854				MCS 855
TS	185 ER	TS1852	79-		MCS 855				MCS 855
DF	200 E TROJAN AGI		96-12		MCB 510	SI			MCS 855
DR	200 K		89-		MCB 510	SI			MCS 855
DR	200 S		15-		MCB 510	SI			
GT	200 N, E	GT200	79-81		MCB 72				MCS 855
TS	200 R		89-		MCB 582	SI			MCB 625 SI
UH	200 Burgman	CD	07-		MCB 776	SRM			MCB 724
UH	200 G Burgman	CD	07-		MCB 776	SRM			MCB 724
AN	250 Burgman	AN	98-99	4	MCB 706 SRM	EC			MCB 685 SRM
AN	250 Sky wave		07-08	4	MCB 582 SRM				MCB 751 SRM
AN	250 Sky wave		07-08	4	MCB 615 SRM				
DR	250 S	SJ42A	82-88		MCB 615	SI			MCS 855
DR	250 S	SJ42A	89-94		MCB 582	SI	SV		MCB 625 SI
DR	250 S	SJ45A	95-		MCB 669	SI	RSI	EC	MCB 625 SI
DRZ	250		01-		MCB 669	SI	RSI	EC	MCB 625 SI
GN	250	NJ41A	82-83		MCB 509				MCS 907
GN	250	NJ42A	84-99		MCB 509				MCS 855
GSF	250 Bandit		90-		MCB 569	SV			MCB 531
GSX	250	GS25X	80-81		MCB 509				MCS 907
GSX	250 E	GS25X	81-		MCB 509				MCS 73
GSX	250 E, ES	GJ53B	82		MCB 501				MCS 73
GSXR	250		88-	*	MCB 542				MCB 531
GSXR	250 R		89-	*	MCB 602	SV			MCB 531
GT	250	GT250	73-78		MCB 16				MCS 904
GT	250 E	GT2502	79-81		MCB 72				MCS 907
GW	250 Inazuma	DC	13-14		MCB 598	SV			MCB 841
GW	250 Inazuma		15-		MCB 598	SV			MCB 634
GZ	250 Marauder	AR	99-01		MCB 550				MCS 855



Option 1

Option 2

Option 3



Option 1

Option 2

Suzuki

LT	250 RF Quadracer		85	*	MCB 523 SI				MCB 510 SI		
LT	250 RH/RJ/RK/RL		87-90	*	MCB 560 SI				MCB 626 SI		
LT-F	250 F		99-02		MCS 841				MCS 842		
LT-F	250 Ozark		02-	*	MCB 510 SI						
LT-F	250		88-01		MCS 841				MCS 842		
LT-Z	250 QuadSport	AJ4AA	04-	*	MCB 510 Si						
RG	250 Gamma	GJ21A	84	*	MCB 531				MCB 531		
RG	250 Gamma	GJ21D	87	*	MCB 547				MCB 531		
RGV	250		88	*	MCB 595	SV	SRQ		MCB 531		
RGV	250	VJ21A	89	*	MCB 602	SV	SRQ		MCB 531		
RGV	250	VJ22B	91-92	*	MCB 602	SV	SRQ	CRQ	MCB 586		
RGV	250	VJ22B	93	*	MCB 602	SV	SRQ	CRQ	MCB 612		
RH	250		85-		MCB 510	SI					
RM	250		83						MCS 915		
RM	250		84						MCS 855		
RM	250	RJ14A	85-		MCB 550						
RM	250	RJ14A	86-		MCB 551						
RM	250	RJ14A	87-88		MCB 582 SI	RSI			MCB 561 SI	EC	
RM	250	RJ14A	89-95		MCB 582 SI	RSI			MCB 625 SI	RSI	
RM	250	RJ18C	96-04		MCB 669 SI	RSI	EC		MCB 575 SI	RSI	EC
RM	250		05-		MCB 669 SI	RSI	EC		MCB 575 SI	RSI	EC
RMX	250	PJ11A	89-93		MCB 582 SI	RSI			MCB 625 SI	RSI	
RMX	250	PJ11A	94-95		MCB 582 SI	RSI			MCB 575 SI	RSI	EC
RMX	250		96-98		MCB 669 SI	RSI	EC		MCB 625 SI	RSI	
RMX	250		99-01		MCB 669 SI	RSI	EC		MCB 575 SI	RSI	EC
RM-Z	250		04-		MCB 669 SI	RSI	EC		MCB 739 SI	RSI	EC
TS	250	TS 250	71-76		MCB 509				MCS 902		
TS	250	TS2504	77-78		MCS 902				MCS 902		
TS	250 X	SJ11D	86-89		MCB 510	SI					
TU	250 X		97-		MCB 550				MCS 855		
VL	250 Intruder	WVA5	00-		MCB 550				MCS 855		
LT-F	300 F		02-	☒	MCB 582 SI				MCS 905		
LT-F	300 F		02-	☒	MCB 615 SI				MCS 905		
LT-F	300 King Quad		99-01						MCS 905		
DR	350 S, SE	SK42B	90-98		MCB 582	SI	SV		MCB 625 SI		
DR	350 W,X		98-99		MCB 669 SI	RSI	EC		MCB 625 SI	RSI	
SP	370	SP370	77-80		MCS 902				MCS 902		
GT	380	GT380	73-77		MCB 16				MCS 904		
AN	400 Burgman	AU	99-02	4 ☒	MCB 706 SRM	EC			MCB 685 SRM		
AN	400 Burgman	BW	03-06	4 ☒	MCB 706 SRM	EC			MCB 746 SRM		
AN	400 S Burgman	BW	05-06	4 ☒	MCB 706 SRM	EC			MCB 746 SRM		
AN	400 Burgman	WVCG	07-11	☒	MCB 582 SRM				MCB 751 SRM		
AN	400 Burgman	WVCG	07-11	☒	MCB 615 SRM						
AN	400 A Burgman ABS	WVCG	09-	☒	MCB 582 SRM				MCB 751 SRM		
AN	400 A Burgman ABS	WVCG	09-	☒	MCB 615 SRM						
AN	400 Z Burgman	WVCG	07-08	☒	MCB 582 SRM				MCB 751 SRM		
AN	400 Z Burgman	WVCG	07-08	☒	MCB 615 SRM						
AN	400 ZA Burgman ABS	WVCG	09-	☒	MCB 582 SRM				MCB 751 SRM		
AN	400 ZA Burgman ABS	WVCG	09-	☒	MCB 615 SRM						
DR	400 S	DR400	80-81		MCS 902				MCS 902		
DR-Z	400 E	WVBF	00-05		MCB 669	SI	RSI	EC	MCB 575 SI	RSI	EC
DR-Z	400 S	WVBC	00-05		MCB 669	SI	RSI	EC	MCB 575 SI	RSI	EC
DR-Z	400 SM	WVB8	05-08		MCB 669	SI	RSI	EC	MCB 575 SI	RSI	EC
GN	400 T,TD,L	GN400	80-82		MCB 509				MCS 907		
GS	400	GS400	77-78		MCB 70						
GS	400 E	GS400	78-79		MCB 72						
GSF	400 Bandit	GK75B	91-92	*	MCB 569	SV			MCB 531	SH	
GSF	400 Bandit	GK75B	93-94	*	MCB 602	SV			MCB 531	SH	
GSF	400 Bandit	GK75B	95-	*	MCB 682	SV			MCB 531	SH	
G SX	400 E	GK53C	82-84		MCB 509				MCS 907		
G SX	400 E	GK53C	85-87		MCB 501				MCS 904		
G SX	400 E, L, S	GS40X	80-81		MCB 509				MCS 907		
G SX	400 FE	GS40XF	81	*	MCB 523				MCB 73		



* 2 Sätze erforderlich – 2 sets required
 Parkbremse – Parkingbrake



ohne Verschleißanzeige – without wear indicator



linke Seite – left side



rechte Seite – right side



Option 1

Option 2

Option 3



Option 1

Option 2

Suzuki

GSX	400 S	GK53C	83-84		MCB 509				MCS 907		
GSX	400 S	GK53C	85-87		MCB 501				MCS 904		
GSX	400 S, Katana	GK53C	92-	*	MCB 602	SV			MCS 904		
GSXR	400		87	*	MCB 542				MCB 531		
GSXR	400		88-	*	MCB 602	SV	SRQ	CRQ	MCB 531	SH	
GSXR	400 R		90-	*	MCB 595	SV	SRQ	CRQ	MCB 531	SH	
LT-A	400 K2 Eiger	AK	02-	*	MCB 510 SI				in Vorber.		
LT-A	400 King Quad		08-12	☞	MCB 788 SI				MCS 959		
LT-A	400 King Quad		08-12	☞	MCB 787 SI				MCS 959		
LT-F	400 K2 Eiger	AK	02-	*	MCB 510 SI				MCS 907		
LT-F	400 K2 Eiger 4WD	AK	02-	*	MCB 510 SI				MCS 907		
LT-F	400 King Quad		08-10	☞	MCB 788 SI				MCS 959		
LT-F	400 King Quad		08-10	☞	MCB 787 SI				MCS 959		
LT-Z	400 Quad Sport	AK	03-	*	MCB 554 SI				MCB 626 SI		
GS	450	GL51F	90-		MCB 569	SV			MCB 569	SH	
GS	450 E, EU, S, SU	GL51F	88		MCB 501				MCS 907		
GS	450 E, L, S,	GS450	80-83		MCB 509				MCS 907		
GS	450 TU	GS450	81		MCB 509				MCS 907		
LT-R	450		06-	☞	MCB 582 SI				MCB 626 SI		
LT-R	450		06-	☞	MCB 615 SI						
RMX	450 Z Efi		10-		MCB 669 SI	RSI	EC		MCB 739 SI	RSI	EC
RMZ	450		05-07		MCB 669 SI	RSI	EC		MCB 739 SI	RSI	EC
RMZ	450 Efi		08-		MCB 669 SI	RSI	EC		MCB 739 SI	RSI	EC
DR	500 S	DR500	81-82		MCS 902				MCS 902		
DR	500 S		89-		MCB 551				MCS 955		
GS	500 E	GS500E	80-81		MCB 72				MCB 73		
GS	500 E	GM51B	89-96		MCB 569	SV			MCB 531	SH	
GS	500 E	GM51B	97-00		MCB 681	SV			MCB 531	SH	
GS	500 E	WVBK	01-03		MCB 681	SV			MCB 531	SH	
GS	500 F	WVBK	04-08		MCB 681	SV			MCB 531	SH	
GT	500	T500	76-77		MCB 16				MCS 904		
LT	500 R		88-	*	MCB 519 SI	EC					
LT	500 RH Quadzilla		87-	*	MCB 560 SI				MCB 561 SI	EC	
LT	500 RL		90	*	MCB 560 SI				MCB 626 SI		
LT-A	500 FK2 Vinson 4WD		02-	*	MCB 510 SI				MCB 523 SI		
LT-A	500 King Quad		11-	☞	MCB 787 SI						
LT-A	500 King Quad		11-	☞	MCB 788 SI						
LT-A	500	AM42A	00-01	☞	MCB 582 SI				MCS 905		
LT-A	500	AM42A	00-01	☞	MCB 615 SI						
LT-F	500 F		03-	*	MCB 510 SI				MCB 723 SI		
LT-F	500 F		98-02	☞	MCB 582 SI				MCS 905		
LT-F	500 F		98-02	☞	MCB 615 SI						
RG	500 Gamma	HM31A	86-87	*	MCB 542				MCB 531		
RM	500		85		MCB 550						
GS	550	GS550	77		MCB 72						
GS	550 D	GS550D	80	*	MCB 501				MCB 73		
GS	550 E	GS550	78-79	*	MCB 72				MCB 73		
GS	550 E, EG	GS550E	80-	*	MCB 501				MCB 73		
GS	550 L	GS550E	80-	*	MCB 501				MCB 73		
GS	550 M	GS550M	81-84	*	MCB 501				MCB 73		
GS	550 T	GS550E	81	*	MCB 501				MCB 73		
GSX	550 E, ES	GN71D	83-86	*	MCB 531				MCB 531		
GT	550	GT550	73-75		MCB 16				MCS 904		
GT	550	GT550	76-77		MCB 72						
DR	600 R, RU	SN41A	89		MCB 551				MCB 612		
DR	600 R, RU	SN41A	86-88		MCB 551				MCS 855		
DR	600 S, SU	SN41A	85-89		MCB 551				MCS 855		
GSF	600 Bandit	GN77B	94-99	*	MCB 598	SV			MCB 531	SH	
GSF	600 Bandit	WVA8	00-04	☞	MCB 682	SV	SRQ				
GSF	600 Bandit	WVA8	00-04	☞	MCB 681	SV	SRQ		MCB 531	SH	
GSF	600 S Bandit	WVA8	00-04	☞	MCB 682	SV	SRQ				
GSF	600 S Bandit	WVA8	00-04	☞	MCB 681	SV	SRQ		MCB 531	SH	
GSR	600	WVB9	06-10	*	MCB 602	SV	SRQ		MCB 783 SH		
GSR	600 A ABS	WVB9	07-10	*	MCB 602	SV	SRQ		MCB 783 SH		
GSX	600 F, FU	GN72B	88-97	*	MCB 591	SV			MCB 531	SH	



Option 1

Option 2

Option 3



Option 1

Option 2

Suzuki

GSX	600 F, FU	WVAJ	98-02		☒	MCB 682	SV	SRQ		MCB 531	SH
GSX	600 F, FU	WVAJ	98-02		☒	MCB 681	SV	SRQ			
GSXR	600	AD	97-00		*	MCB 602 SV	SRQ	CRQ		MCB 531	SH
GSXR	600	WVBG	01-03		*	MCB 602 SV	SRQ	CRQ		MCB 531	SH
GSXR	600	WVB2	04-05		*	MCB 752 SV	SRQ	CRQ	SCR	MCB 729	SH
GSXR	600	WVCE	06-07		*	MCB 752 SV	SRQ	CRQ	SCR	MCB 783 SH	
GSXR	600	WVCV	08-10		*	MCB 752 SV	SRQ	CRQ	SCR	MCB 783 SH	
GSXR	600	C3	11-	Brembo	*	MCB 792 SV	SRQ	CRQ	SCR	MCB 784 SH	
RF	600 R, RU	GN76B	93-96		*	MCB 598	SV	SRQ		MCB 531	SH
VS	600 Intruder	VN51B	94-97			MCB 542				MCS 959	
AN	650 Burgman	WVBU	02-11		*	MCB 598 SRM				MCB 751 SRM	
AN	650 A Burgman ABS	WVBU	04-12		*	MCB 598 SRM				MCB 751 SRM	
AN	650 A Burgman ABS	WVBU	13-		*	MCB 598 SRM				MCB 751 SRM	
AN	650 Z Burgman Executive ABS	WVBU	13-		*	MCB 598 SRM				MCB 751 SRM	
DL	650 V-Strom	WVB1	04-11		☒	MCB 682	SV			MCB 634	SH
DL	650 V-Strom	WVB1	04-11		☒	MCB 681	SV				
DL	650 A V-Strom ABS	WVB1	07-11		☒	MCB 682	SV			MCB 634	SH
DL	650 A V-Strom ABS	WVB1	07-11		☒	MCB 681	SV				
DL	650 A V-Strom ABS	C7	12-		☒	MCB 682	SV			MCB 634	SH
DL	650 A V-Strom ABS	C7	12-		☒	MCB 681	SV				
DR	650 R, RU	SP41B	90-91			MCB 551				MCB 612	SH
DR	650 R, RU	SP44B	92-94			MCB 597	SV			MCB 612	SH
DR	650 RE, REU	SP45B	94-95			MCB 597	SV			MCB 612	SH
DR	650 RS, RSU	SP42B	90-91			MCB 597	SV			MCB 612	SH
DR	650 RSE, RSEU	SP43B	91-96			MCB 597	SV			MCB 612	SH
DR	650 SE, SEU	SP46B	96-00			MCB 669 SI	SV	RSI	EC	MCB 625 SI	
GR	650	GP51A	83-84			MCB 501				MCS 907	
GR	650 X	GP51A	83-89			MCB 501				MCS 907	
GS	650 G	GS650G	81-83		*	MCB 501				MCB 73	
GSF	650 Bandit	WVB5	05-06		☒	MCB 682	SV	SRQ		MCB 729	SH
GSF	650 Bandit	WVB5	05-06		☒	MCB 681	SV	SRQ			
GSF	650 Bandit	WVCJ	07-08		*	MCB 602	SV	SRQ		MCB 634	SH
GSF	650 Bandit	WVCZ	09-12		*	MCB 602	SV	SRQ		MCB 634	SH
GSF	650 A Bandit ABS	WVB5	05-06		☒	MCB 682	SV	SRQ		MCB 634	SH
GSF	650 A Bandit ABS	WVB5	05-06		☒	MCB 681	SV	SRQ			
GSF	650 A Bandit ABS	WVCJ	07-08		*	MCB 602	SV	SRQ		MCB 634	SH
GSF	650 A Bandit ABS	WVCZ	09-12		*	MCB 602	SV	SRQ		MCB 634	SH
GSF	650 S Bandit	WVB5	05-06		☒	MCB 682	SV	SRQ		MCB 729	SH
GSF	650 S Bandit	WVB5	05-06		☒	MCB 681	SV	SRQ			
GSF	650 S Bandit	WVCJ	07-08		*	MCB 602	SV	SRQ		MCB 634	SH
GSF	650 S Bandit	WVCZ	09-12		*	MCB 602	SV	SRQ		MCB 634	SH
GSF	650 SA Bandit ABS	WVB5	05-06		☒	MCB 682	SV	SRQ			
GSF	650 SA Bandit ABS	WVB5	05-06		☒	MCB 681	SV	SRQ		MCB 634	SH
GSF	650 SA Bandit ABS	WVCJ	07-08		*	MCB 602	SV	SRQ		MCB 634	SH
GSF	650 SA Bandit ABS	WVCZ	09-12		*	MCB 602	SV	SRQ		MCB 634	SH
GSX	650 F	WVCJ	08-		*	MCB 602	SV			MCB 634	SH
GSX	650 F	WVCZ	12-		*	MCB 602	SV			MCB 634	SH
GSX	650 FA ABS	WVCJ	09-		*	MCB 602	SV			MCB 634	SH
GSX	650 FA ABS	WVCZ	12-		*	MCB 602	SV			MCB 634	SH
LS	650 F Savage	NP41B	86-01			MCB 550				MCS 907	
LS	650 P Savage	NP41B	86-01			MCB 550				MCS 907	
SFV	650 Gladius	WVCX	09-		☒	MCB 682	SV				
SFV	650 Gladius	WVCX	09-		☒	MCB 681	SV			MCB 841	SH
SFV	650 Gladius ABS	WVCX	09-		☒	MCB 682	SV				
SFV	650 Gladius ABS	WVCX	09-		☒	MCB 681	SV			MCB 841	SH
SV	650	AV111	99-02		☒	MCB 682	SV	SRQ			
SV	650	AV111	99-02		☒	MCB 681	SV	SRQ		MCB 531	SH
SV	650	WVBY	03-09		☒	MCB 682	SV	SRQ			
SV	650	WVBY	03-09		☒	MCB 681	SV	SRQ		MCB 634	SH
SV	650 A ABS	WVBY	07-09		☒	MCB 682	SV	SRQ			
SV	650 A ABS	WVBY	07-09		☒	MCB 681	SV	SRQ		MCB 634	SH
SV	650 S	AV111	99-02		☒	MCB 682	SV	SRQ			
SV	650 S	AV111	99-02		☒	MCB 681	SV	SRQ		MCB 531	SH



* 2 Sätze erforderlich – 2 sets required
Parkbremse – Parkingbrake



ohne Verschleißanzeige – without wear indicator



linke Seite – left side



rechte Seite – right side



Option 1

Option 2

Option 3



Option 1

Option 2

Suzuki

SV	650 S	WVBY	03-10		MCB 682	SV	SRQ			
SV	650 S	WVBY	03-10		MCB 681	SV	SRQ	MCB 634	SH	
SV	650 SA ABS	WVBY	07-10		MCB 682	SV	SRQ			
SV	650 SA ABS	WVBY	07-10		MCB 681	SV	SRQ	MCB 634	SH	
XF	650 Freewind	AC	97-02		MCB 681	SV		MCB 585	SH	
	700 Quadrunner		04-		MCB 757 SI					
	700 Quadrunner		04-		MCB 758 SI					
LT-A	700 King Quad		05-07		MCB 787 SI					
LT-A	700 King Quad		05-07		MCB 788 SI					
DR	750 S, SU	SR41B	88		MCB 597	SV		MCS 907		
DR	750 S, SU	SR41B	89		MCB 597	SV		MCB 612	SH	
GS	750	GS750	77-79		MCB 70			MCB 73		
GS	750 D	GS750D	77-79		MCB 70			MCB 73		
GS	750 E	GS750E	78-79		MCB 70			MCB 73		
GS	750 L	GS750E	79	*	MCB 72			MCB 73		
GSR	750	C5	11		MCB 681	SV	SRQ	MCB 634	SH	
GSR	750	C5	11		MCB 682	SV	SRQ			
GSR	750 A ABS	C5	11-		MCB 681	SV	SRQ	MCB 634	SH	
GSR	750 A ABS	C5	11-		MCB 682	SV	SRQ			
GSX	750	AE	98-02		MCB 682	SV	SRQ			
GSX	750	AE	98-02		MCB 681	SV	SRQ	MCB 531	SH	
GSX	750 E	GS75X	80-82	*	MCB 509			MCB 73		
GSX	750 EF	GR72A	85-	*	MCB 509			MCB 73		
GSX	750 EG	GS75X	80-81		MCB 509			MCB 73		
GSX	750 ES	GR72A	83-87	*	MCB 509			MCB 73		
GSX	750 F	GR78A	89-97	*	MCB 591	SV		MCB 531	SH	
GSX	750 F	WVAK	98-06		MCB 682	SV	SRQ			
GSX	750 F	WVAK	98-06		MCB 681	SV	SRQ	MCB 531	SH	
GSX	750 L	GS75X	80-81	*	MCB 509			MCB 73		
GSX	750 S	GR71A	82-	*	MCB 501			MCB 73		
GSXR	750	GR75A	85-87	*	MCB 542			MCB 531		
GSXR	750	GR77B	88-89	*	MCB 595	SV	SRQ	CRQ	MCB 531	SH
GSXR	750	GR7AB	90-91	*	MCB 595	SV	SRQ	CRQ	MCB 531	SH
GSXR	750	GR7BB	92-93	*	MCB 595	SV	SRQ	CRQ	MCB 531	SH
GSXR	750	GR7BB	94-95	*	MCB 659 SV	SRQ	CRQ		MCB 531	SH
GSXR	750	GR7DB	96-99	*	MCB 659 SV	SRQ	CRQ		MCB 531	SH
GSXR	750	WVBD	00-03	*	MCB 602 SV	SRQ	CRQ		MCB 531	SH
GSXR	750	WVB3	04-05	*	MCB 752 SV	SRQ	CRQ	SCR	MCB 729	SH
GSXR	750	WVCF	06-07	*	MCB 752 SV	SRQ	CRQ	SCR	MCB 783 SH	
GSXR	750	WVCW	08-10	*	MCB 752 SV	SRQ	CRQ	SCR	MCB 783 SH	
GSXR	750	C4	11-	Brembo	MCB 792 SV	SRQ	CRQ	SCR	MCB 784 SH	
GT	750	GT750	73-77		MCB 16				MCS 905	
LT-A	750 King Quad		08-		MCB 787 SI					
LT-A	750 King Quad		08-		MCB 788 SI					
VS	750 GLF Intruder	VR51B	86-89		MCB 542			MCS 959		
VS	750 GLP Intruder	VR51B	86-91		MCB 542			MCS 959		
C	800 Intruder, C Intruder	WVBM	07-		MCB 681	SV		MCS 959		
DR	800 S, SU	SR42B	90		MCB 597	SV		MCB 612	SH	
DR	800 S, SU	SR43B	91-96		MCB 569	SV		MCB 615	SH	
DR	800 S, SU	SR43B	96-99		MCB 682	SV		MCB 604		
DR-Z	800		88-90		MCB 597	SV		MCB 561	EC	
DR-Z	800 Dzeta		91		MCB 597	SV		MCB 612	SH	
VL	800 Intruder LC Volusia	WVBM	01-06		MCB 681	SV		MCS 959		
VS	800 GL Intruder	VS52B	92-00		MCB 542			MCS 959		
VX	800 L	VS51B	90-95		MCB 569	SV		MCB 591	SH	
VX	800 U	VS51B	96-01	*	MCB 682	SV		MCB 531	SH	
VZ	800 M 800 Intruder	WVB4	05-		MCB 681	SV		MCS 959		
VZ	800 Marauder	AF	97-03		MCB 681	SV		MCS 959		
GS	850 E, L, G, GL	GS 850	80-82	*	MCB 509			MCB 73		
GS	850 G	GS 850	79	*	MCB 70			MCB 73		
GS	850 G	GS72A	83-86	*	MCB 509			MCB 73		
XN	850	GR71A	83-	*	MCB 501			MCB 73		
RF	900 R	GT73B	94-97	*	MCB 690	SV		MCB 678	SH	
DL	1000 V-Strom	WVBS	02-09		MCB 682	SV				
DL	1000 V-Strom	WVBS	02-09		MCB 681	SV		MCB 634	SH	



Option 1

Option 2

Option 3



Option 1

Option 2

Suzuki

DL	1000 V-Strom ABS	DD	14-		*	MCB 752 SV				MCB 783 SH	
GS	1000 E	GS1000	78-80		*	MCB 72				MCB 73	
GS	1000 E, H	GS1000	80		*	MCB 72				MCB 73	
GS	1000 G, GL	GS100G	80-81		*	MCB 509				MCB 73	
GS	1000 S	GS1000	82		*	MCB 501				MCB 73	
GSXR	1000	WVBL	01-02		*	MCB 659 SV	SRQ	CRQ		MCB 729 SH	
GSXR	1000	WVBZ	03-04	4 ☐	*	MCB 742 SV	SRQ	CRQ	SCR	MCB 729 SH	
GSXR	1000	WVB6	05-06		*	MCB 752 SV	SRQ	CRQ	SCR	MCB 729 SH	
GSXR	1000	WVCL	07-08		*	MCB 752 SV	SRQ	CRQ	SCR	MCB 783 SH	
GSXR	1000	WVCY	09-11		*	MCB 752 SV	SRQ	CRQ	SCR	MCB 784 SH	
GSXR	1000	WVCY	12-14	Brembo	*	MCB 792 SV	SRQ	CRQ	SCR	MCB 784 SH	
GSXR	1000 ABS		15-	Brembo	*	MCB 792 SV	SRQ	CRQ	SCR	MCB 784 SH	
GSX-S	1000 ABS	DG	15-	Brembo	*	MCB 792 SV	SRQ	CRQ	SCR	MCB 784 SH	
GSX-S	1000 F ABS	DG	15-	Brembo	*	MCB 792 SV	SRQ	CRQ	SCR	MCB 784 SH	
SV	1000	WVBX	03-08		*	MCB 602	SV	SRQ	CRQ	MCB 634	SH
SV	1000 S	WVBX	03-08		*	MCB 602	SV	SRQ	CRQ	MCB 634	SH
TL	1000 R	AM321	98-02		*	MCB 659 SV	SRQ	CRQ		MCB 531	SH
TL	1000 S	AG111	97-01		*	MCB 602 SV	SRQ	CRQ		MCB 531	SH
GS	1100 G	GU71A	86		*	MCB 509				MCB 73	
GS	1100 G	GU73A	84-85		*	MCB 509				MCB 73	
GSX	1100	GS110X	80-81		*	MCB 501				MCB 542	
GSX	1100	GU71B	82-83		*	MCB 501				MCB 73	
GSX	1100 E	GS110X	81-83		*	MCB 501				MCB 73	
GSX	1100 E, EF, ES	GV71C	84-87		*	MCB 542				MCB 542	
GSX	1100 EX	GV71B	83		*	MCB 501				MCB 73	
GSX	1100 F	GV72C	88-92		*	MCB 591	SV			MCB 542	
GSX	1100 F	GV72C	93-96		*	MCB 591	SV			MCB 531	SH
GSX	1100 G	GV74A	91-93		*	MCB 569	SV			MCB 591	SH
GSX	1100 G	GV74A	94-95		*	MCB 569	SV			MCB 586	
GSX	1100 G	GV74A	96-	☒	*	MCB 682	SV	SRQ			
GSX	1100 G	GV74A	96-	☒	*	MCB 681	SV	SRQ		MCB 531	SH
GSXR	1100	GV74CD	86-88		*	MCB 542				MCB 531	
GSXR	1100	GV73C	89-92		*	MCB 595	SV	SRQ	CRQ	MCB 531	SH
GSXR	1100	GU75C	93-97		*	MCB 659 SV	SRQ	CRQ		MCB 531	SH
GT	1100		80-		*	MCB 501				MCB 73	
GSF	1200 Bandit	GV75A	96-00		*	MCB 690	SV			MCB 531	SH
GSF	1200 Bandit	WVA9	01-05		*	MCB 659	SV	SRQ	CRQ	MCB 531	
GSF	1200 Bandit	WVCB	06		*	MCB 602	SV	SRQ	CRQ	MCB 634	SH
GSF	1200 S Bandit	GV75A	96-00		*	MCB 690	SV			MCB 531	SH
GSF	1200 S Bandit	WVA9	01-05		*	MCB 659	SV	SRQ	CRQ	MCB 531	
GSF	1200 S Bandit	WVCB	06		*	MCB 602	SV	SRQ	CRQ	MCB 634	SH
GSX	1200 FS	WVA3	99-01		*	MCB 683	SV	SRQ	CRQ	MCB 531	SH
GSF	1250 A Bandit ABS	WVCH	07-		*	MCB 602	SV	SRQ	CRQ	MCB 634	SH
GSF	1250 SA Bandit ABS	WVCH	07-14		*	MCB 602	SV	SRQ	CRQ	MCB 634	SH
GSF	1250 SA Bandit ABS		15-		*	MCB 602	SV	SRQ	CRQ	MCB 634	SH
GSX	1250 FA ABS	WVCH	10-		*	MCB 602	SV	SRQ	CRQ	MCB 634	SH
GSX	1300 BK B-King	WVCR	07-		*	MCB 737 SV	SRQ	CRQ		MCB 783 SH	SH
GSX	1300 BKA B-King ABS	WVCR	07-		*	MCB 737 SV	SRQ	CRQ		MCB 783 SH	SH
GSX	1300 R Hayabusa	WVA1	99-07		*	MCB 659 SV	SRQ	CRQ		MCB 531	SH
GSX	1300 R Hayabusa	WVCK	08-12		*	MCB 752 SV	SRQ	CRQ	SCR	MCB 783 SH	
GSX	1300 RA Hayabusa ABS	WVCK	13-		*	MCB 792 SV	SRQ	CRQ	SCR	MCB 783 SH	
GSX	1400	WVBN	01-07		*	MCB 659	SV	SRQ	CRQ	MCB 729	
VS	1400 GLP Intruder	VX51L/LD	87-03			MCB 542				MCB 542	
VL	1500 LC Intruder	WVAL	98-04			MCB 542				MCB 542	
VL	1500 C 1500 Intruder	WVAL	02-08	☒		MCB 682	SV				
VL	1500 C 1500 Intruder	WVAL	02-08	☒		MCB 681	SV			MCB 741	SH
VL	1500 C 1500 T Intruder	C1	13-			MCB 598	SV			MCB 843	SH
VZ	1500 M 1500 Intruder	WVCU	09-10	☒		MCB 682	SV				
VZ	1500 M 1500 Intruder	WVCU	09-10	☒		MCB 681	SV			MCB 843	SH
VZ	1600 M 1600 Intruder	VNT60B	04	4 ☐		MCB 742 SV				MCB 843	SH
VZ	1600 M 1600 Marauder	VNT60B	04-05			MCB 659	SV			MCB 843	SH
VLR	1800 C 1800 R Intruder	WVCT	08-11		*	MCB 776 SV				MCB 843	SH



* 2 Sätze erforderlich – 2 sets required
 ☐ Parkbremse – Parkingbrake

☒ ohne Verschleißanzeige – without wear indicator
 ☒ linke Seite – left side
 ☒ rechte Seite – right side



Option 1

Option 2

Option 3



Option 1

Option 2

Suzuki

VZR	1800 M 1800 R Intruder	WVCA	06-		*	MCB 752 SV				MCB 843	SH
VZR	1800 M 1800 R2 Intruder	WVCA	08-09		*	MCB 752 SV				MCB 843	SH

SYM

DD	50		02-			MCB 589				MCS 800	
RS	50		04-			MCB 779					
	50 Allo		11-			MCB 684	EC				
	50 Big Wheel					MCB 684	EC				
	50 Cinderella		01-			MCB 589				MCS 800	
	50 Crox		14-			MCB 684	EC				
	50 Fancy		95-			MCB 684	EC			MCS 800	
	50 Fiddle	AW05W	99-05			MCS 800				MCS 813	
	50 Fiddle II	AW12W	07-			MCB 684	EC			MCS 800	
	50 Gypsy		99-06	AU: Bolwell		MCB 519	EC				
	50 Jet 4 R, Naked		10-			MCB 684	EC				
	50 Jet BasiX		07-			MCB 684	EC			MCS 800	
	50 Jet Euro X		99-			MCB 684	EC			MCS 800	
	50 Jet Sport X R/SR		06-			MCB 708	EC			MCB 686	
	50 Jet, Alpha	G5J	95-			MCB 684	EC			MCS 800	
	50 Jive		04	AU: Bolwell		MCB 517					
	50 Jolie		04-06	AU: Bolwell		MCB 589					
	50 Jungle	GA05W	96-			MCB 684	EC			MCS 800	
	50 Mask, LC	BF05W	00-			MCB 684	EC			MCS 800	
	50 Mio		05-			MCB 589				MCS 800	
	50 Orbit	AV12W	08-09			MCB 647				MCS 800	
	50 Orbit II	AV12W	12-			MCB 684	EC				
	50 Pure	F5B-2	95-			MCB 589					
	50 Red Devil	G5J	98-			MCB 684	EC			MCS 800	
	50 Retro		05-06	AU: Bolwell							
	50 Shark		99-			MCB 779				MCS 834	
	50 Super Fancy	FT05W	98-			MCB 684	EC			MCS 800	
SR	50 Symphony		09-			MCB 684	EC			MCS 843	
	50 Symply		08-			MCB 684	EC				
	50 Wave		95-			MCB 590	EC			MCS 962	
	50 X'Pro		14-			MCB 684	EC				
	100 Bella		04-05	AU: Bolwell		MCB 684	EC				
	100 Jet	G5J	95-			MCB 684	EC			MCS 800	
	100 Jet	G100P	99-			MCB 684	EC			MCS 800	
	100 Mio	HU10W	05-			MCB 589				MCS 800	
	100 Super Fancy	G5H-6				MCB 684	EC			MCS 800	
	110 Ariba		99-05	AU: Bolwell		MCB 589					
	110 Star		03-			MCB 684	EC				
	125 Allo		11-			MCB 684	EC				
	125 Attila SR		99-			MCB 684	EC			MCS 800	
	125 Cinderella		01-			MCB 589				MCS 800	
	125 CityCom		09-			MCB 684	EC			MCB 800	SRM
	125 Crox		14-			MCB 684	EC				
	125 Duke		95-			MCB 684	EC			MCS 800	
	125 Euro-MX		02-			MCB 779				MCS 834	
HD2	125 Evo i		07-			MCB 684	EC			MCB 800	SRM
	125 Fiddle II		09-			MCB 684	EC			MCS 843	
	125 G-Max		05-06	AU: Bolwell		MCB 540	SV			MCB 519	EC
	125 Husky	N125A-6	96-98			MCB 523					
	125 Husky	N125A-6	99-			MCB 719					
	125 Jet 4 Naked		10-			MCB 684	EC			MCS 843	
GTS	125 Joymax evo i.		07-			MCB 800	SRM			MCB 800	SRM
	125 Joyride	LA15W	01-09			MCB 779				MCB 800	SRM
	125 Joyride Evo		10-			MCB 779				MCB 800	SRM
	125 Legrande		04-06	AU: Bolwell		MCB 779					
	125 Megalo	AK12W	02-			MCB 684	EC			MCS 834	
	125 Orbit II		08-			MCB 647					
	125 Shark		99-02			MCB 779				MCS 834	
	125 Shark 4VR		00-02			MCB 779				MCB 663	EC
	125 Super Duke	A125Q2-2	96-			MCB 684	EC			MCS 800	
SR	125 Symphony		09-			MCB 684	EC			MCS 843	



Option 1

Option 2

Option 3



Option 1

Option 2

SYM

	125 Symply		08-		MCB 684	EC		MCS 843		
	125 Voyager		05-		MCB 800	SRM		MCB 800	SRM	
	125 X'Pro		14-		MCB 684	EC				
HD	125		04-07		MCB 712	SRM		MCS 834		
VS	125		06-		MCB 779					
	150 Ariba		99-05	AU: Bolwell	MCB 589					
	150 Attila	H125D	00-		MCB 684	EC		MCS 800		
	150 CityCom		09-		MCB 684	EC		MCB 800	SRM	
	150 G-Max		05-06	AU: Bolwell	MCB 540	SV		MCB 519	EC	
	150 Husky		99-		MCB 719			MCS 990		
	150 Joyride		01-		MCB 779			MCB 712	SRM	
	150 Shark		99-02		MCB 779			MCS 834		
	150 Shark		04-06	AU: Bolwell	MCB 779			MCB 615	EC	
	150 Shark 4VR		00-02		MCB 779			MCB 663	EC	
	150 Super Duke		96-		MCB 684	EC		MCS 800		
GTS	150		07-		MCB 800	SRM		MCB 800	SRM	
VS	150		06-		MCB 779					
MF	180		03-		MCB 525	EC				
	180 Joyride		01-		MCB 779			MCB 712	SRM	
HD	200		04-07		MCB 712	SRM		MCS 834		
HD2	200 Evo i		07-		MCB 684	EC		MCB 800	SRM	
	200 Joyride		03-		MCB 779			MCB 712	SRM	
	200 Legrande		04-06	AU: Bolwell	MCB 779					
	200 Track Runner		05-		* MCB 760 SI			MCB 800		
GTS	200		07-		4 ☐ MCB 706	SRM EC				
	250 Firenze		06-07	AU: Bolwell	4 ☐ MCB 732			MCB 800		
	250 G-Max		05-06	AU: Bolwell	MCB 540	SV		MCB 519	EC	
GTS	250 Joymax		07-		4 ☐ MCB 732 SRM			MCB 800 SRM		
GTS	250 Joymax evo i.		09-		4 ☐ MCB 732 SRM			MCB 800 SRM		
	250 Quadlander		05-09		* MCB 760 SI			MCB 800		
	250 Voyager, Voymax		05-		4 ☐ MCB 732	SRM		MCB 821	SRM EC	
SN	250 Ni Wolf		14-		MCB 849 SRM			MCB 760		
	300 City Max		06-		* MCB 760 SI			MCB 800		
	300 CityCom i.		09-		MCB 684	EC		MCB 684	EC	
	300 Quadlander		06-10		* MCB 760 SI			MCB 760 SI		
	300 Wolf Cafe Racer		15-		MCB 849 SRM			MCB 760		
	300 Wolf Classic		15-		MCB 849 SRM			MCB 760		
	400 MaxSym i		11		* MCB 847 SRM			MCB 873 SRM		
	400 MaxSym i		12-		* MCB 849 SRM			MCB 873 SRM		
GT	500		05-		4 ☐ MCB 706 SRM			MCB 712 SRM		
	600 MaxSym i		14-		* MCB 849 SRM			MCB 873 SRM		
	600 Quad Raider		08-		* MCB 760 SI			MCB 760 SI		

TGB

	50 101R	BH1	05-		MCB 519	EC				
	50 101S, 202T, 303R		98-		MCB 519	EC				
	50 203R		05-		MCB 689	EC				
	50 309, 409 RS		00-		MCB 519	EC				
	50 Akros		94-		MCB 519	EC		MCS 990		
	50 Akros tec 5	GH5	99-		MCB 689	EC		MCS 990		
	50 Apollo		98-		MCB 689	EC				
	50 Bull&T RS		11-		MCB 519	EC		MCB 519	EC	
	50 Bullet RS, RR		06-11		MCB 765			MCB 522		
	50 Bunny		94-		MCB 519	EC				
	50 City 4T		07-11		MCB 519	EC		MCS 990		
	50 Corona Sport, Comfort		02-	Pegasus	MCB 523					
	50 Ergon		94-		MCB 519	EC				
	50 Express		06-		MCB 519	EC		MCS 990		
SKY	50 High wheels	G15	02-	Pegasus	MCB 519	EC		MCS 990		
	50 HIWS		99-		MCB 519	EC				
	50 KBX		94-		MCB 519	EC				
	50 Palio		94-		MCB 523					
	50 Sky		97-	Pegasus	MCB 689	EC				



* 2 Sätze erforderlich – 2 sets required
Parkbremse – Parkingbrake



ohne Verschleißanzeige – without wear indicator
linke Seite – left side
rechte Seite – right side



Option 1

Option 2

Option 3



Option 1

Option 2

TGB

50 Tapo RR, RS	11-		MCB 519	EC					
50 Trigger	99-		MCB 519	EC			MCS 990		
90 101S, 202T, 303R	98-		MCB 519	EC					
90 Apollo	98-		MCB 689	EC					
125 101S, 202T, 303R	98-		MCB 519	EC			MCS 962		
125 309, 409 RS	00-		MCB 519	EC			MCS 962		
125 Bellavista EFI	12-		MCB 684	EC			MCB 710	EC	
125 Bullet RS, RR	08-		MCB 765				MCB 519	EC	
125 Corona Sport, Comfort	02-	Pegasus	MCB 523						
125 Express	04-		MCB 765						
125 Sky	97-	Pegasus	MCB 689	EC					
125 X-Large	11-		MCB 837 SRM				MCB 800 SRM		
125 X-Motion ie	09-		MCB 837 SRM				MCB 800 SRM		
250 Blade	06-07		* MCB 523 SI				MCB 519 SI		EC
250 Dynasty	06-		MCB 615 SRM	EC			MCB 590		
250 X-Motion ie	08-		MCB 837 SRM				MCB 800 SRM		
300 Bellavista EFI	12-		MCB 684	EC			MCB 710	EC	
300 X-Motion ie	10-		MCB 837 SRM				MCB 800 SRM		
325 Blade LE, SL	07-		* MCB 519 SI				MCB 523 SI		
325 Target	09-11		* MCB 519 SI	EC			MCB 523 SI		
400 Avenger	07-10		* MCB 760 SI				MCB 760 SI		
400 Target	09-10		* MCB 519 SI	EC			MCB 523 SI		
425 Blade SE	07-10		* MCB 760 SI				MCB 760 SI		
425 Target	09-11		* MCB 519 SI	EC			MCB 523 SI		
460 Blade R Target	12		* MCB 519 SI	EC			MCB 523 SI		
500 Avenger	09-10		* MCB 760 SI				MCB 760 SI		
500 Blade SE, SL	07-		* MCB 760 SI				MCB 523 SI		
500 Target	09-10		* MCB 519 SI	EC			MCB 523 SI		
525 Blade SE	09-		* MCB 760 SI				MCB 760 SI		
525 Target	09-11		* MCB 519 SI	EC			MCB 523 SI		
550 Blade SE, SL, LT	09-		* MCB 760 SI				MCB 523 SI		
550 Target	10-		* MCB 519 SI	EC			MCB 523 SI		

TM

80 alle Modelle	90-93		MCB 579	SI			MCB 519	SI	EC
80 alle Modelle	94-		MCB 648 SI	RSI	EC		MCB 672 SI	RSI	EC
80 GS/MC	-89		MCB 579	SI			MCB 75	SI	
85	13-		MCB 730 SI	RSI			MCB 730 SI	RSI	
125	90-93		MCB 579	SI			MCB 519	SI	EC
125	94-00		MCB 648 SI	RSI	EC		MCB 672 SI	RSI	EC
125 GS/MC	-89		MCB 579	SI			MCB 75	SI	
125	01-04		MCB 648 SI	RSI	EC		MCB 575 SI	RSI	EC
125	05-		MCB 648 SI	RSI	EC		MCB 739 SI	RSI	EC
250 Enduro	95-00		MCB 648 SI	RSI	EC		MCB 672 SI	RSI	EC
250 , F	01-04		MCB 648 SI	RSI	EC		MCB 575 SI	RSI	EC
250 , F	05-		MCB 648 SI	RSI	EC		MCB 739 SI	RSI	EC
300	01-04		MCB 648 SI	RSI	EC		MCB 575 SI	RSI	EC
300	05-		MCB 648 SI	RSI	EC		MCB 739 SI	RSI	EC
400 F	00		MCB 648 SI	RSI	EC		MCB 672 SI	RSI	EC
400 F	01		MCB 648 SI	RSI	EC		MCB 575 SI	RSI	EC
450 F	02-04		MCB 648 SI	RSI	EC		MCB 575 SI	RSI	EC
450 F	05-		MCB 648 SI	RSI	EC		MCB 739 SI	RSI	EC
530 F	01-04		MCB 648 SI	RSI	EC		MCB 575 SI	RSI	EC
530 F	05-		MCB 648 SI	RSI	EC		MCB 739 SI	RSI	EC

Triumph

600 Daytona	806LW	03-04	* MCB 595	SV	SRQ	CRQ	MCB 585	SH	
600 Speed Four	806LB	02-06	* MCB 595	SV	SRQ	CRQ	MCB 585	SH	
TT 600	806AD	00-03	* MCB 595	SV	SRQ	CRQ	MCB 585	SH	
650 Daytona	865LX	05	* MCB 595	SV	SRQ	CRQ	MCB 585	SH	
650 Thunderbird		81-	MCB 99						
675 Daytona	D67LC	06-08	* MCB 737 SV	SRQ	CRQ		MCB 585	SH	
675 Daytona	D67LC	09-11	* MCB 816 SV	SRQ	CRQ		MCB 585	SH	
675 Daytona	H67	12	* MCB 816 SV	SRQ	CRQ		MCB 585	SH	
675 Daytona	H67	13-	* MCB 816 SV	SRQ	CRQ		MCB 672	SH	
675 Daytona ABS	H67	13-	* MCB 816 SV	SRQ	CRQ		MCB 672	SH	



Option 1

Option 2

Option 3



Option 1

Option 2

Triumph

675 Daytona R	H67	12	Radialc.	*	MCB 858 SV	SRQ	CRQ	SCR	MCB 585	SH
675 Daytona R	H67	13-	Radialc.	*	MCB 858 SV	SRQ	CRQ	SCR	MCB 672	SH
675 Daytona R ABS	H67	13-	Radialc.	*	MCB 858 SV	SRQ	CRQ	SCR	MCB 672	SH
675 Street Triple	D67LD	08-12		*	MCB 598 SV	SRQ			MCB 585	SH
675 Street Triple ABS	D67LD	08-12		*	MCB 598 SV	SRQ			MCB 585	SH
675 Street Triple	L67LR	13-		*	MCB 598 SV	SRQ			MCB 672	SH
675 Street Triple ABS	L67LR	13-		*	MCB 598 SV	SRQ			MCB 672	SH
675 Street Triple R	D67LD	09-12		*	MCB 737 SV	SRQ	CRQ		MCB 585	SH
675 Street Triple R ABS	D67LD	09-12		*	MCB 737 SV	SRQ	CRQ		MCB 585	SH
675 Street Triple R	L67LR	13-		*	MCB 737 SV	SRQ	CRQ		MCB 672	SH
675 Street Triple R ABS	L67LR	13-		*	MCB 737 SV	SRQ	CRQ		MCB 672	SH
675 Street Triple RX ABS		15-		*	MCB 737 SV	SRQ	CRQ		MCB 672	SH
750 Bonneville 750		84-			MCB 533					
750 Bonneville T140V		75-83			MCB 99				MCB 99	
750 Bonneville U.K.		87-		*	MCB 19				MCB 19	
750 Daytona	330BEM	91-		*	MCB 595	SV	SRQ	CRQ	MCB 604	SH
750 Trident	T300C	91-96		☒	MCB 582	SV			MCB 604	SH
750 Trident	T300C	91-96		☒	MCB 615	SV				
750 TSS		82-83			MCB 99				MCB 99	
800 Bonneville, America, T100	908MD	01-06			MCB 598	SV			MCB 582	SH
800 Speedmaster	986ML	03-04		*	MCB 598	SV	SRQ		MCB 582	SH
800 Tiger, XC, ABS	A08	11-14		*	MCB 598	SV			MCB 585	SH
800 Tiger XR/XRx ABS		15-		*	MCB 598	SV			MCB 585	SH
800 Tiger XC/XCx ABS		15-		*	MCB 598	SV			MCB 585	SH
865 America	986MK	07-			MCB 598	SV			MCB 582	SH
865 Bonneville, T100	986MF	05-			MCB 598	SV			MCB 582	SH
865 Bonneville Newchurch		15-			MCB 598	SV			MCB 582	SH
865 Bonneville Spirit		15-			MCB 598	SV			MCB 582	SH
865 Bonneville T214		15-			MCB 598	SV			MCB 582	SH
865 Scrambler	986MG	06-			MCB 598	SV			MCB 582	SH
865 Speedmaster	986ML	05-			MCB 598	SV			MCB 582	SH
865 Thruxton	986ME	04-			MCB 598	SV			MCB 582	SH
865 Thruxton Ace		15-			MCB 598	SV			MCB 582	SH
900 Adventurer	T309	96-01			MCB 598	SV			MCB 598	
900 Daytona	T300D	93-96		*	MCB 595 SV	SRQ	CRQ		MCB 582	SH
900 Daytona Super III	T300B	94-96		*	MCB 656 SV	SRQ			MCB 582	SH
900 Legend	T309RT	99-01			MCB 598	SV			MCB 598	
900 Speed Triple	T300B	94-96		*	MCB 595 SV	SRQ	CRQ		MCB 604	SH
900 Speed Triple	T509	97-98		*	MCB 595 SV	SRQ	CRQ		MCB 582	SH
900 Sprint	T300A	91-93		☒	MCB 582	SV			MCB 582	SH
900 Sprint	T300A	91-93		☒	MCB 615	SV				
900 Sprint	T300A	94-99		*	MCB 595	SV	SRQ		MCB 604	SH
900 Thunderbird		95-04			MCB 598	SV	SRQ		MCB 598	
900 Thunderbird Sport		95-04			MCB 598	SV	SRQ		MCB 598	
900 Tiger	T400	93-98		☒	MCB 582	SV			MCB 604	SH
900 Tiger	T400	93-98		☒	MCB 615	SV				
900 Tiger	T709	99-01		*	MCB 598	SV	SRQ		MCB 598	
900 Trident	T300C	91-98		☒	MCB 582	SV			MCB 604	SH
900 Trident	T300C	91-98		☒	MCB 615	SV				
900 Trophy	T300E	91-92		☒	MCB 582	SV			MCB 582	SH
900 Trophy	T300E	91-92		☒	MCB 615	SV				
900 Trophy		93-01		*	MCB 595	SV	SRQ	CRQ	MCB 604	SH
955 Daytona i	T595	96-01		*	MCB 595	SV	SRQ	CRQ	MCB 582	SH
955 Daytona i	595N	02-06		*	MCB 595	SV	SRQ	CRQ	MCB 582	SH
955 Speed Triple	595N	02-04		*	MCB 595	SV	SRQ	CRQ	MCB 582	SH
955 Speed Triple	T509	99-01		*	MCB 595	SV	SRQ	CRQ	MCB 582	SH
955 Sprint RS	T695	99-02		*	MCB 595	SV	SRQ		MCB 604	SH
955 Sprint RS	T695	03-04		*	MCB 595	SV	SRQ		MCB 582	SH
955 Sprint ST	T695	99-04		*	MCB 595	SV	SRQ		MCB 582	SH
955 Tiger i	709EN	01-04		*	MCB 598	SV			MCB 598	
955 Tiger i	709EN	05-06		*	MCB 598	SV			MCB 604	SH
1000 Daytona	T300	92		*	MCB 595	SV	SRQ	CRQ	MCB 604	SH
1050 Speed Triple	515NJ	05-07	Nissin	*	MCB 737 SV	SRQ	CRQ		MCB 582	SH



* 2 Sätze erforderlich – 2 sets required
Parkbremse – Parkingbrake



ohne Verschleißanzeige – without wear indicator



linke Seite – left side



rechte Seite – right side



Option 1

Option 2

Option 3



Option 1

Option 2

Triumph

1050 Speed Triple	515NJ	08-11	Brembo	4☐ *	MCB 721 SV	SRQ	CRQ		MCB 582	SH
1050 Speed Triple ABS	515NJ	08-11	Brembo	4☐ *	MCB 721 SV	SRQ	CRQ		MCB 582	SH
1050 Speed Triple	515NV	11-	Brembo	4☐ *	MCB 721 SV	SRQ	CRQ		MCB 582	SH
1050 Speed Triple ABS	515NV	11-	Brembo	4☐ *	MCB 721 SV	SRQ	CRQ		MCB 582	SH
1050 Speed Triple R	515NV	11-	Brembo Monob.	*	MCB 792 SV	SRQ	CRQ	SCR	MCB 582	SH
1050 Speed Triple R ABS	515NV	11-	Brembo Monob.	*	MCB 792 SV	SRQ	CRQ	SCR	MCB 582	SH
1050 Sprint GT ABS	215ND	11-		*	MCB 595	SV	SRQ		MCB 582	SH
1050 Sprint ST	215NA	05-10		*	MCB 595	SV	SRQ		MCB 582	SH
1050 Sprint ST ABS	215NA	07-10		*	MCB 595	SV	SRQ		MCB 582	SH
1050 Tiger	115NG	07-10		*	MCB 737 SV				MCB 604	SH
1050 Tiger ABS	115NG	07-		*	MCB 737 SV				MCB 604	SH
1050 Tiger SE	115NG	10-12		*	MCB 737 SV				MCB 604	SH
1050 Tiger SE ABS	115NG	10-		*	MCB 737 SV				MCB 604	SH
1050 Tiger Sport ABS		15-		*	MCB 737 SV				MCB 582	SH
1200 Daytona	T300	93-97		*	MCB 595	SV	SRQ	CRQ	MCB 604	SH
1200 Tiger Explorer, XC, ABS	V13VG	12-		*	MCB 595	SV			MCB 582	SH
1200 Trophy ABS	V13VH	13-	Brembo	*	MCB 706	SV			MCB 582	SH
1200 Trophy SE ABS	V13VH	13-	Brembo	*	MCB 706	SV			MCB 582	SH
1200 Trophy	342CSM	91-92		☐	MCB 582	SV			MCB 582	SH
1200 Trophy	342CSM	91-92		☐	MCB 615	SV				
1200 Trophy	342CSM	93-03		*	MCB 595	SV	SRQ		MCB 604	SH
1600 Thunderbird	B16BA	09-		*	MCB 595	SV			MCB 671	SH
1600 Thunderbird ABS	B16BA	09-		*	MCB 595	SV			MCB 671	SH
1700 Thunderbird Storm	B16BA	11-		*	MCB 595	SV			MCB 671	SH
1700 Thunderbird Storm ABS	B16BA	11-		*	MCB 595	SV			MCB 671	SH
1700 Thunderbird Commander ABS		14-		*	MCB 595	SV			MCB 671	SH
1700 Thunderbird LT ABS		14-		*	MCB 595	SV			MCB 671	SH
1700 Thunderbird Nightstorm ABS		15-		*	MCB 595	SV			MCB 671	SH
2300 Rocket III	C23XB	04-09		*	MCB 595	SV			MCB 671	SH
2300 Rocket III Roadster ABS	C23XB	10-		*	MCB 595	SV			MCB 671	SH
2300 Rocket III Touring	23XC	08-10		*	MCB 595	SV			MCB 671	SH
2300 Rocket III Touring ABS	23XC	08-		*	MCB 595	SV			MCB 671	SH
2300 Rocket X ABS		15-		*	MCB 595	SV			MCB 671	SH
TSS Electro 8 Va		84-			MCB 533					
TSX		82-83			MCB 99				MCB 99	

Vectrix

VX-1		07-	Electric		MCB 648	SRM			MCB 648	SRM
------	--	-----	----------	--	---------	-----	--	--	---------	-----

Victory

1500 alle Modelle		00-06			MCB 683	SV			MCB 671	SH
1634 Hammer, Hammer S		05-07			MCB 683	SV			MCB 671	SH
1634 Hammer, Hammer S		08-		*	MCB 737	SV			MCB 599	SH
1634 Kingpin		06-07			MCB 683	SV			MCB 671	SH
1634 Kingpin		08-			MCB 595	SV			MCB 599	SH
1634 Vegas, 8-Ball		06-07			MCB 683	SV			MCB 671	SH
1634 Vegas, 8-Ball, High Ball		08-			MCB 737	SV			MCB 599	SH
1731 Cross Country, ABS		10-		*	MCB 704	SV			MCB 599	SH
1731 Cross Roads Classic, ABS		10-		*	MCB 704	SV			MCB 599	SH
1731 Gunner		15-			MCB 737	SV			MCB 599	SH
1731 Hammer, Hammer S		09-		*	MCB 737	SV			MCB 599	SH
1731 Judge, Boardwalk		13-			MCB 737	SV			MCB 599	SH
1731 Magnum		15-		*	MCB 737	SV			MCB 599	SH
1731 Vegas Jackpot		09-			MCB 737	SV			MCB 599	SH
1731 Vegas, 8-Ball, High Ball		10-			MCB 737	SV			MCB 599	SH
1731 Vision Tour, ABS		08-		*	MCB 704	SV			MCB 599	SH

VOR

EN	400		00-02		MCB 648 SI	RSI	EC		MCB 672 SI	RSI	EC
MX	400		00-02		MCB 648 SI	RSI	EC		MCB 672 SI	RSI	EC
SM	400		00-02		MCB 540	SRQ	CRQ		MCB 672 SI	RSI	EC
EN	450		02-05		MCB 648 SI	RSI	EC		MCB 672 SI	RSI	EC
MX	450		02-05		MCB 648 SI	RSI	EC		MCB 672 SI	RSI	EC
SM	450		02-05		MCB 540	SRQ	CRQ		MCB 672 SI	RSI	EC
EN	500		00-02		MCB 648 SI	RSI	EC		MCB 672 SI	RSI	EC



Option 1

Option 2

Option 3



Option 1

Option 2

VOR

MX	500		00-02			MCB 648 SI	RSI	EC		MCB 672 SI	RSI	EC
SM	500		00-02			MCB 540	SRQ	CRQ		MCB 672 SI	RSI	EC
EN	530		02-05			MCB 648 SI	RSI	EC		MCB 672 SI	RSI	EC
MX	530		02-05			MCB 648 SI	RSI	EC		MCB 672 SI	RSI	EC
SM	530		02-05			MCB 540	SRQ	CRQ		MCB 672 SI	RSI	EC
SM	570		04-05			MCB 540	SRQ	CRQ		MCB 672 SI	RSI	EC

Voxan

	1000 Cafe Racer	V2	01-05		*	MCB 540 SV	SRQ	CRQ		MCB 700	RQ	
	1000 Cafe Racer		06-		*	MCB 683 SV	SRQ	CRQ		MCB 700	RQ	
	1000 Roadster	V2	01-05		*	MCB 540 SV	SRQ	CRQ		MCB 700	RQ	
	1000 Srambler		01-03		*	MCB 540 SV	SRQ	CRQ		MCB 604		
VB1	1000 EVO		03-04		*	MCB 683 SV	SRQ	CRQ		MCB 700	RQ	
	1000 Roadster		06-		*	MCB 683 SV	SRQ	CRQ		MCB 700	RQ	
GTV	1200		08-		4 ☐ *	MCB 721SV	SRQ	CRQ	SCR	MCB 700	RQ	

Wuyang

WY	50 QT		06-			MCB 590	EC			MCS 800		
WY	125 125-12, 125-16C		06-			MCB 765						
WY	125 125-24B		06-			MCB 615	SRM	EC				

Yamaha

BW's	50		99-04			MCB 674	EC	SR		MCS 962		
BW's	50		05-			MCB 674	EC	SR				
CA	50 E	14T	83-85			MCS 960				MCS 961		
CG	50 Jog		88-92			MCS 960				MCS 961		
CS	50 Jog R, Jog RR	SA22	01-05			MCB 674	EC	SR		MCS 962		
CS	50 Jog R, Jog RR	SA22	06-12			MCB 674	EC	SR				
CS	50 Jog R, Jog RR	SA48	13-			MCB 674	EC	SR				
CV	50 Beluga	39H	-89			MCS 961				MCS 961		
CV	50 Beluga		90-			MCS 956				MCS 961		
CV	50 Jog	3WG	00-02			MCB 728						
CV	50 Jog	SA22	03-08			MCB 838						
CV	50 ZR Evolution		01-02			MCB 728						
CW	50 Bump	4VA	97-99			MCB 674	EC	SR		MCS 962		
CW	50 BWs	4BX	91-96			MCS 956				MCS 956		
CW	50 NG BWs	4VA	95-98			MCB 674				MCS 962		
CW	50 NG BWs	SA05	99-07			MCB 674	EC	SR		MCS 962		
CW	50 Spy	4VA	95-99			MCB 674	EC	SR		MCS 962		
DT	50 LC		98-			MCB 558	SI			MCS 956		
DT	50 M	2M4	80-84			MCS 951				MCS 951		
DT	50 MX	13N	71-85			MCS 951				MCS 951		
DT	50 MX	1NN	86-91			MCS 956				MCS 956		
DT	50 MX		92-95			MCS 962				MCS 962		
DT	50 R	3MN	89-90	Japan		MCB 539	EC	SI		MCS 956		
DT	50 R	MBK	96-01			MCB 578				MCS 956		
DT	50 R		02-08			MCB 735	EC			MCB 735	EC	
DT	50 X		04-08			MCB 734				MCB 735	EC	
EW	50 Slider	SA09	00-06			MCB 701	EC	SR		MCS 962		
FS1	50 G, DX	1J6	76			MCS 951				MCS 951		
FS1	50 DX	468	77-78			MCB 14				MCS 951		
FS1	50 DX	3F2	79-			MCB 506				MCS 951		
LB2	50 M Chappy	551	81-84			MCS 951				MCS 951		
NS	50 R Aerox	SA42	13-			MCB 674	EC	SR		MCB 701	EC	SR
NS	50 R Aerox Naked	SA42	13-			MCB 674	EC	SR		MCB 701	EC	SR
PW	50	4X4	80-87			MCS 960				MCS 960		
PW	50	36E	88-90			MCS 960				MCS 960		
PW	50	3PT	91-			MCS 960				MCS 960		
RD	50	353	78			MCB 14				MCS 961		
RD	50 M	2	79-84			MCB 506				MCS 951		
RD	50 MX	13M	81-84			MCB 521				MCS 951		
SG	50 Sting	34N	84-			MCS 961				MCS 961		
SH	50 Mint		93-			MCS 960				MCS 961		



* 2 Sätze erforderlich – 2 sets required
Parkbremse – Parkingbrake



ohne Verschleißanzeige – without wear indicator



linke Seite – left side



rechte Seite – right side



Option 1

Option 2

Option 3



Option 1

Option 2

Yamaha

SH	50 Razz		93-		MCS 960				MCS 961		
TDR	50		88-02		MCB 539	EC	SI		MCB 539	EC	SI
TT-R	50 E	CA01	06-		MCS 827				MCS 827		
TY	50 M	1G3	77-80		MCS 951				MCS 951		
TZR	50	RA03/RA04	03-		MCB 734				MCB 535		
YA	50 Axis	5AK	92-	Japan	MCB 590				MCS 962		
YA	50 Axis	3UG	96-98	Europe	MCB 644	EC			MCS 962		
YE	50 Zest	4FW	92		MCB 644	EC			MCS 962		
YE	50 Zest	4FW	93-95	Italy	MCB 674	EC	SR				
YE	50 Zest	4FW	93-95	Japan	MCB 590	EC			MCS 961		
YFM	50 Raptor		04-		MCS 962				MCS 962		
YH	50 Why	SA03	99-		MCB 674	EC	SR		MCS 962		
YM	50 Breeze	4KH	94-95		MCB 674	EC	SR		MCS 962		
YM	50 Breeze	4RC	95-98		MCB 644	EC			MCS 956		
YN	50 Neo's	5AD	97-01		MCB 674	EC	SR		MCS 962		
YN	50 Neo's	SA15	02-03		MCB 674	EC	SR		MCS 962		
YN	50 Neo's	SA21	04-06		MCB 674	EC	SR		MCS 962		
YN	50 Neo's 2T	SA34	07-		MCB 674	EC	SR				
YN	50 Neo's 4T	SA40	07-		MCB 674	EC	SR				
YQ	50 Aerox		96		MCB 644	EC			MCS 956		
YQ	50 Aerox	5BR	97-01		MCB 644	EC			MCB 701	EC	SR
YQ	50 Aerox L	SA14	02-12		MCB 644	EC			MCB 701	EC	SR
YQ	50 Aerox R	SA14	03-12		MCB 644	EC			MCB 701	EC	SR
YZ	50		80-83		MCS 963				MCS 963		
YZ	60		82-84		MCS 963				MCS 963		
V	75		77		MCS 951				MCS 951		
BW	80		86-		MCS 963				MCS 963		
CV	80 Beluga		-89		MCS 962				MCS 962		
CV	80 Beluga		90-		MCS 956				MCS 961		
DT	80 LC1	37A	81-84		MCS 953				MCS 953		
DT	80 LC2	53V, 3WC	85-92		MCB 539	EC	SI		MCS 953		
DT	80 LC2	53V, 4ED1	85-97		MCB 539	EC	SI		MCS 968		
DT	80 MX	5J1	81-83		MCS 953				MCS 953		
DT	80 MXS	5T8	84-85		MCS 956				MCS 956		
FS	80 SE	5A7	81-84		MCS 951				MCS 951		
GT	80		77-80		MCS 953				MCS 953		
MX	80 H		81		MCS 951				MCS 951		
PW	80	4BC	83-91		MCS 963				MCS 956		
PW	80	4BC	92-		MCS 963				MCS 962		
RD	80 LC1	10X	82-84		MCB 524				MCS 951		
RD	80 LC2	30W	83-86		MCB 539	EC	SI		MCS 951		
RD	80 MX	5G1	81-84		MCB 521				MCS 951		
RX	80 SE	12N	82-84		MCB 521				MCS 951		
TY	80		76-78		MCS 963				MCS 951		
TZR	80		-91		MCB 590				MCB 539	EC	
TZR	80 R		92-		MCB 615	SV	EC		MCB 539	EC	
V	80		81-83		MCS 951				MCS 951		
YE	80 Zest	4MU	93-97		MCB 590	EC			MCS 961		
YFM	80 Badger	4EM	95-01		MCS 962				MCS 953		
YFM	80 Grizzly		05-08		MCS 962				MCS 953		
YFM	80 Raptor	AB02	02-08		MCS 962				MCS 953		
YZ	80		77-79		MCS 963				MCS 951		
YZ	80		80-85		MCS 963				MCS 963		
YZ	80		86-90		MCB 558 SI				MCS 963		
YZ	80	4GT/4LB	93-97		MCB 558 SI				MCB 561 SI	EC	
YZ	80	CB01	98-01		MCB 558 SI				MCB 561 SI	EC	
YZ	80 LW	CB02	98-01		MCB 558 SI				MCB 561 SI	EC	
YZ	85 LW	CB05	02-03		MCB 558 SI				MCB 561 SI	EC	
YZ	85 SW	CB04	02-03		MCB 558 SI				MCB 561 SI	EC	
YZ	85 LW	CB08/10	04-		MCB 558 SI				MCB 561 SI	EC	
YZ	85 SW	CB07/09	04-		MCB 558 SI				MCB 561 SI	EC	
TT-R	90	CB03	00-04		MCS 963				MCS 962		
TT-R	90 E	CB06	04-08		MCS 963				MCS 962		
YFM	90 Raptor		10-		MCS 962				MCB 523 SI		
AG	100		73-91		MCS 951				MCS 953		



Option 1

Option 2

Option 3



Option 1

Option 2

Yamaha

AG	100		92-01		MCS 956				MCS 968		
BW's	100		99-	Japan	MCB 590	EC			MCS 953		
BW's	100		99-	Italy	MCB 644	EC			MCS 953		
DT	100 S		77-82		MCS 951				MCS 953		
DT	100		74-77		MCS 951				MCS 953		
MX	100 W		83-91		MCS 951				MCS 953		
RS	100	4J8	75-76		MCS 951				MCS 951		
RS	100 DX	1Y8	79-80		MCB 14				MCS 951		
RSX	100	1Y8	80-81		MCS 956				MCS 956		
RT	100		93-01		MCS 962				MCS 962		
YB	100		77-80		MCS 951				MCS 951		
YFM	100		89-91		MCS 962				MCS 953		
YN	100 Neo's	SB04	00-03		MCB 674	EC	SR		MCS 953		
YQ	100 Aerox	SB05	00-04		MCB 674	EC	SR		MCS 953		
YW	100 Bee Wee		06-08		MCB 590				MCS 953		
YZ	100 E-H		78-81		MCS 951				MCS 953		
YZ	100		82-83		MCS 962				MCS 953		
TT-R	110		08-09		MCS 963				MCS 962		
	110 Crypton		98-		MCB 539	EC			MCS 956		
	115 D'elight		14-		MCB 812						
BW's	125	SE55	10-		MCB 835						
DT	125 E	AT2	74-75		MCS 953				MCS 953		
DT	125 E	1G0	76-79		MCS 953				MCS 953		
DT	125 LC	10V	82-84		MCB 539	SI	EC		MCS 953		
DT	125 R, RH, RN	4BL	91-98		MCB 539	SI	EC		MCB 539	SI	EC
DT	125 RH, RN	DE03	99-03		MCB 539	SI	EC		MCB 539	SI	EC
DT	125 RE	DE06	04-06		MCB 539	SI	EC		MCB 625 SI	RSI	
DT	125 X	DE06	05-06		MCB 671	SV			MCB 625 SI	RSI	
DT	125 Tenere		89-90		MCB 539	SI	EC		MCS 953		
HW	125 Xenter	SE59	12-		MCB 835				MCS 962		
IT	125		80		MCS 951				MCS 953		
MT	125 , ABS		14-		MCB 785	SV	SRQ		MCB 760		
RD	125	AS3, 1E7	75-77		MCB 14				MCS 953		
RD	125 DX	2R6	78-79		MCB 44				MCS 955		
RD	125 LC	10W	82-84		MCB 524				MCS 953		
RD	125 LC	10W	85-87		MCB 541				MCS 953		
SR	125 SE	10F	92-96		MCB 524				MCS 956		
SR	125	10F	96-03		MCB 666	SV			MCS 956		
TDR	125		91-92	Italy	MCB 579	SI			MCB 560 SI		
TDR	125	4GW	93-96	Japan	MCB 666	SV			MCB 539	EC	
TDR	125	5AN	97-02	Japan	MCB 666	SV			MCB 539	EC	
TT-R	125 LW	CE07	00-11		MCB 558				MCS 962		
TW	125 Trailway	DE01	99-02		MCB 699				MCS 962		
TW	125 Trailway	DE05	03-04		MCB 699						
TZ	125	4TJ	94-97		* MCB 611	SV	SRQ	CRQ	MCB 636		
TZ	125	CE02	98		* MCB 611	SV	SRQ	CRQ	MCB 636		
TZ	125	CE04	99		* MCB 611	SV	SRQ	CRQ	MCB 636		
TZ	125	CE06	00-03		* MCB 611	SV	SRQ	CRQ	MCB 636		
TZR	125		90-92		MCB 530				MCB 541		
TZR	125	4FL	93-99		MCB 666	SV			MCB 530		
TZR	125 Italy		91-95	Brembo	MCB 540	SV	SRQ	CRQ	MCB 553		
VP	125 X-City	SE43	08-	Nissin	MCB 631 SRM				MCB 700 SRM	EC	
WR	125		98-		MCB 574	SI	RSI		MCB 575	SI	
WR	125 R	DE07	09-		MCB 598				MCB 672	SI	EC
WR	125 X	DE07	09-		MCB 598				MCB 672	SI	EC
XC	125 Beluga	50W/51F	85-87		MCS 953				MCS 953		
XC	125 Beluga	3TE	88-92		MCS 969				MCS 953		
XC	125 Beluga	3TE	93-95		MCS 969				MCS 968		
XC	125 T Cygnus	4NB	95-00		MCS 969				MCS 962		
XC	125 TR Cygnus	4NB	96-99		MCB 539	EC					
XC	125 F Cygnus	SE03	00-04		MCB 539	EC					
NXC	125 X Cygnus	SE08	04-06		MCB 774						
NXC	125 X Cygnus	SE41	07-09		MCB 774						



* 2 Sätze erforderlich – 2 sets required
Parkbremse – Parkingbrake



ohne Verschleißanzeige – without wear indicator
linke Seite – left side
rechte Seite – right side



Option 1

Option 2

Option 3



Option 1

Option 2

Yamaha

NXC	125 X Cygnus	SE41	10-		MCB 839						
XC	125 Vity		08-		MCB 812						
XN	125 Teos	SE04	00-03		MCB 674	EC	SR		MCS 968		
XQ	125 Maxster	SE05	01-03		MCB 648	SRM			MCB 700	SRM	EC
XT	125		82		MCS 953				MCS 962		
XT	125 R	7401	05-		MCB 735	EC			MCB 735	EC	
XT	125 X	7401	05-		MCB 734	EC			MCB 735	EC	
XV	125 Virago	5AJ	97-01		MCB 666	SV			MCS 968		
XVS	125 Drag Star	VE01	00-04		MCB 666	SV			MCS 968		
YBR	125 Custom	RE07	08-		MCB 812						
YBR	125 ED	RE03	05		MCB 539	EC			MCS 968		
YBR	125 ED	RE04	06		MCB 539	EC			MCS 968		
YBR	125 ED	RE05	07-		MCB 812						
YBR	125 ED (Brasil)		06-08		MCB 812				MCS 968		
YBR	125 E/K (Brasil)		00-08		MCS 968				MCS 968		
YFA	125 Breeze		89-91		MCS 962				MCS 953		
YFA	125 Breeze	3FA	92-04		MCS 962				MCS 968		
YFM	125 Grizzly	AE02	04-		MCS 962				MCS 968		
YP	125 Majesty	SE02	98-01		MCB 648	SRM	EC		MCS 968		
YP	125 Majesty	SE06	01-09		MCB 648	SRM	EC		MCB 700	SRM	EC
YP	125 R X-Max	SE32	06-09	Brembo	MCB 786	SRM			MCB 700	SRM	EC
YP	125 R X-Max	SE54	10-	Nissin	MCB 631 SRM				MCB 700	SRM	EC
YP	125 R X-Max ABS	SE54	11-	Nissin	MCB 631 SRM				MCB 699	SRM	
YZ	125		76-82						MCS 953		
YZ	125	24X	83						MCS 964		
YZ	125	43M	84						MCS 964		
YZ	125	55Y,1LX	85-86		MCB 549 SI				MCS 964		
YZ	125	2HG	87		MCB 549 SI				MCS 953		
YZ	125	2VN	88		MCB 549 SI				MCB 539 SI	EC	
YZ	125	3JD	89		MCB 582 SI	RSI			MCB 554 SI		
YZ	125		90-97		MCB 582 SI	RSI			MCB 625 SI	RSI	
YZ	125		98-02		MCB 669 SI	RSI	EC		MCB 575 SI	RSI	EC
YZ	125	CE10-15	03-07		MCB 669 SI	RSI	EC		MCB 739 SI	RSI	EC
YZ	125	CE16	08-		MCB 791 SI	RSI	EC		MCB 739 SI	RSI	EC
YZF-R	125	RE06	08-13		MCB 648	EC			MCB 760		
YZF-R	125	RE11	14-		MCB 785	SV	SRQ		MCB 760		
	135 Crypton, Sniper		06-08		MCB 812				MCS 953		
HW	150 Xenter		12-		MCB 835				MCS 962		
XQ	150 Maxster	SG06	01-03		MCB 648 SRM	EC			MCB 700 SRM	EC	
YP	150 Majesty		00		MCB 648 SRM	EC			MCS 968		
YP	150 Majesty	SG08	01-		MCB 648 SRM	EC			MCB 700 SRM	EC	
DT	175	CT1	74-75		MCS 953				MCS 953		
DT	175	1G1	76-77		MCS 953				MCS 953		
DT	175 MX	2K4	78-83		MCS 953				MCS 953		
XC	180 Cygnus	32H	83-84		MCS 969				MCS 953		
XL	180		83-		MCS 953				MCS 955		
YP	180 R Majesty	SG12	03-		MCB 648 SRM	EC			MCB 700 SRM	EC	
XC	185 Beluga		93-		MCS 969				MCS 969		
BW	200		85-		MCS 956				MCS 956		
DT	200 R		85-87		MCB 539	SI	EC		MCS 953		
DT	200 R		88-93		MCB 539	SI	EC		MCB 539	SI	EC
IT	200 LN		84		MCS 964				MCS 964		
IT	200 S		87-		MCB 549				MCS 964		
RD	200 DX	1E8	75-77		MCB 14				MCS 955		
RD	200 DX	1E8	78-80		MCB 506				MCS 955		
TT	200		86-		MCB 539	SI	EC		MCS 956		
TW	200		01-02		MCB 699				MCS 962		
YFS	200 Blaster	3JM	88-02		MCS 962						
YFS	200 Blaster	AG02	03-07		* MCB 510 SI				MCB 561 SI		EC
TT	225		87-		MCB 539	SI	EC		MCS 956		
XT	225 Serow		86-87		MCB 539	SI	EC		MCS 956		
TTR	230		05-		MCB 582						
DT	250	512	75-76		MCS 952				MCS 955		
DT	250 MX	1R7	77-82		MCS 952				MCS 955		
FZR	250		87-88		MCB 559	SV			MCB 541	SH	



Option 1

Option 2

Option 3



Option 1

Option 2

Yamaha

FZR	250 R		89-		MCB 616				MCB 541		
FZX	250 Zeal		98-00		MCB 640	SV			MCB 541		
IT	250		81-84						MCS 955		
IT	250		85-		MCB 539	SI	EC		MCS 955		
RD	250	522	73-75		MCB 44				MCS 954		
RD	250	1A2	76-77		MCB 44				MCB 44		
RD	250	1A2	78-79		MCB 503				MCB 503		
RD	250 LC	4L1	80		MCB 507				MCS 954		
RD	250 LC	4L1	81		MCB 521				MCS 954		
RD	250 LC	4L1	82-83		MCB 524				MCB 530		
SR	250 SE	3Y8	80-83		MCS 952				MCS 953		
SR	250	3Y9	92-93	ES, AU	MCB 524				MCS 953		
SR	250 Classic	21LS	96-00	ES, AU	MCB 524				MCS 953		
SRV	250		95-98		MCB 640	SV			MCS 968		
SRX	250		85-87		MCB 542				MCS 955		
TDR	250	3CK	88-90		MCB 559				MCB 541		
TT	250 R	4MR	93-00		MCB 582 SI	RSI			MCB 625 SI		
TT	250 SOHC		80-82						MCS 953		
TY	250 Z		95		MCB 582 SI	RSI			MCB 582 SI	RSI	
TY	250		74-78		MCS 951				MCS 953		
TZ	250	4DP	90-95		* MCB 595	SRQ			MCB 636		
TZ	250	4TW	96-97		* MCB 595	SRQ			MCB 636		
TZ	250	CG03/06/09	98-02		* MCB 595	SRQ			MCB 636		
TZ	250	CG15	03-		* MCB 595	SRQ			MCB 636		
TZR	250	2MA	85-88		MCB 559	SV			MCB 541	SH	
TZR	250	3MA	89-92		MCB 611 SV	SRQ	CRQ		MCB 541	SH	
VP	250 X-City	SG19	07-		MCB 631 SRM				MCB 699 SRM		
WR	250	4JW	94-97		MCB 582 SI	RSI			MCB 625 SI	RSI	
WR	250	4SR	98-02		MCB 669 SI	RSI	EC		MCB 575 SI	RSI	EC
WR	250 F	CG11	01-02		MCB 669 SI	RSI	EC		MCB 575 SI	RSI	EC
WR	250 F	CG16	03-04		MCB 669 SI	RSI	EC		MCB 739 SI	RSI	EC
WR	250 F	CG2	05-07		MCB 669 SI	RSI	EC		MCB 739 SI	RSI	EC
WR	250 F	CG3	08-14		MCB 669 SI	RSI	EC		MCB 739 SI	RSI	EC
WR	250 F		15-		MCB 791 SI				MCB 739 SI	RSI	EC
WR	250 R	DG20	08-		MCB 669 SI	RSI	EC		MCB 739 SI	RSI	EC
WR	250 X	DG20	08-		MCB 598	SV	SRQ		MCB 739 SI	RSI	EC
XG	250 Tricker	DG14	04-06		MCB 699				MCB 625 SI		
XS	250 SE, SF	4A2,1U5	80-		MCB 68				MCS 958		
XT	250	3Y3	80-91		MCS 953				MCS 953		
XT	250 223 ccm		94-06		MCB 539	EC			MCS 956		
XT	250 DOHC		83-87		MCB 539	EC			MCS 953		
XT	250 X		08-		MCB 669 SI	RSI	EC		MCB 625 SI	RSI	
XV	250 H Virago	3LS	89-93		MCB 524				MCS 968		
XV	250 N Virago	3LW	89-96		MCB 524				MCS 953		
XV	250 S Virago	3LW	95-98		MCB 666	SV			MCS 968		
XV	250 S Virago	VG01	99-00		MCB 666	SV			MCS 968		
XVS	250 Drag Star	VG03	01-04		MCB 666	SV			MCS 968		
YBR	250	RG02	07-11		MCB 615	EC					
YFB	250 Timberwolf		92-94		MCS 962				MCS 833		
YFB	250 Timberwolf		94-00		MCS 833				MCS 833		
YFM	250 Bear Tracker		99-00		MCS 833				MCS 833		
YFM	250 Bear Tracker	AG01	00-04		* MCB 510 SI						
YFM	250 Big Bear	AG01	07-11		* MCB 510 SI						
YFM	250 Bruin	AG01	05-06		* MCB 510 SI						
YFM	250 Raptor	AG03/06	08-		☞ MCB 801 SI				MCB 561 SI		
YFM	250 Raptor	AG03/06	08-		☞ MCB 802 SI						
YP	250 Majesty	4UC	96-99		MCB 666 SRM				MCS 958		
YP	250 Majesty	SG04	00-02		MCB 666 SRM				MCB 699 SRM		
YP	250 A Majesty ABS	SG04	03		MCB 666 SRM				MCB 699 SRM		
YP	250 DX Majesty	SG02	98-99		MCB 666 SRM				MCB 699 SRM		
YP	250 DXA Majesty ABS	SG02	99-03		MCB 666 SRM				MCB 699 SRM		
YP	250 R X-Max	SG16	05-09	Brembo	MCB 786 SRM				MCB 699 SRM		
YP	250 R X-Max	SG22	10-12	Nissin	MCB 631 SRM				MCB 699 SRM		



* 2 Sätze erforderlich – 2 sets required
Parkbremse – Parkingbrake



ohne Verschleißanzeige – without wear indicator
linke Seite – left side
rechte Seite – right side



Option 1

Option 2

Option 3



Option 1

Option 2

Yamaha

YP	250 R X-Max ABS	SG22	11-12	Nissin	MCB 631 SRM			MCB 699 SRM		
YP	250 R X-Max	SG25	13-	Nissin	MCB 631 SRM			MCB 699 SRM		
YP	250 R X-Max ABS	SG25	13-	Nissin	MCB 631 SRM			MCB 699 SRM		
YZ	250		77-79					MCS 952		
YZ	250		80					MCS 953		
YZ	250		81					MCS 953		
YZ	250		82-84					MCS 953		
YZ	250		85-87		MCB 549 SI			MCS 953		
YZ	250		88		MCB 549 SI			MCB 539 SI	EC	
YZ	250		89		MCB 582 SI	RSI		MCB 554 SI		
YZ	250		90-96		MCB 582 SI	RSI		MCB 625 SI	RSI	
YZ	250	CG0	97-01		MCB 669 SI	RSI	EC	MCB 575 SI	RSI	EC
YZ	250	CG1	02-04		MCB 669 SI	RSI	EC	MCB 739 SI	RSI	EC
YZ	250	CG2	05-06		MCB 669 SI	RSI	EC	MCB 739 SI	RSI	EC
YZ	250	CG2	07-		MCB 791 SI	RSI		MCB 739 SI	RSI	
YZ	250 F	CG1	01-04		MCB 669 SI	RSI	EC	MCB 739 SI	RSI	EC
YZ	250 F	CG2	05-06		MCB 669 SI	RSI	EC	MCB 739 SI	RSI	EC
YZ	250 F	CG2	07-09		MCB 791 SI	RSI		MCB 739 SI	RSI	
YZ	250 F	CG3	10-		MCB 791 SI	RSI		MCB 739 SI	RSI	
YZF	300 R3		15-		MCB 812			MCB 812		
VP	300 Versity	SH01	03-05		MCB 648 SRM			MCB 648 SRM		
RD	350	521	73-79		MCB 44			MCS 954		
RD	350 LC	4L0	80	*	MCB 507			MCS 954		
RD	350 LC	4L0	81-83	*	MCB 521			MCS 954		
RD	350 LC, YPVS	31K	83-84	*	MCB 524			MCB 530		
RD	350 LC, LCF, YPVS	31K	85	*	MCB 541			MCB 541		
RD	350 LC, LCF, YPVS	1WW, 1WX	86-89	*	MCB 541			MCB 541		
TT	350		86-90		MCB 549	SI		MCS 968		
TT	350		91-95		MCB 582	SI		MCB 625 SI		
XT	350 H, N	55V	85-90		MCB 539	SI	EC	MCS 968		
XT	350 N	3YT	91-95		MCB 539	SI	EC	MCS 968		
YFM	350 Bruin	AH0, AH1	04-09	*	MCB 510 SI			MCS 958		
YFM	350 ER		89-95		MCS 833					
YFM	350 FW Big Bear		96-98		MCS 844			MCS 958		
YFM	350 FW W-G		89-95		MCS 844					
YFM	350 L Big Bear	4WU	99	*	MCB 510 SI			MCS 958		
YFM	350 Grizzly 2x4, 4x4	AH1, AH2	07-	*	MCB 510 SI			MCS 958		
YFM	350 Wolverine	AH4, 4KB	95-05	*	MCB 510 SI			MCS 958		
YFM	350 R Raptor	AH1	04-	*	MCB 561 SI		EC	MCB 561 SI		
YFM	350 UH, UJ, UK		96-98		MCS 844			MCS 833		
YFM	350 X Warrior	3GD	89-04	*	MCB 510 SI			MCB 554 SI		
YFZ	350 Banshee	3GG	90-	*	MCB 510 SI			MCB 554 SI		
XS	360 SE	1U4	76		MCB 68			MCS 958		
YP	400 X-Max	SH07	13-	*	MCB 631 SRM			MCB 699 SRM		
DT	400	513	75-76		MCS 952			MCS 955		
DT	400 MX	1R6	77-79		MCS 952			MCS 955		
FZR	400		86-	*	MCB 530			MCB 541		
FZR	400 R		87-89	*	MCB 559	SV		MCB 530		
FZR	400 RR	3TJ	90-94	*	MCB 616			MCB 541		
FZR	400 RR	4DX	92	*	MCB 616			MCB 541		
RD	400	1A3	76-77		MCB 44			MCB 44		
RD	400	1A3	78-79		MCB 503			MCB 503		
SR	400	RH05	14-		MCB 666	SV				
WR	400 F	CH02	98		MCB 669 SI	RSI	EC	MCB 625 SI	RSI	
WR	400 F	CH04	99-02		MCB 669 SI	RSI	EC	MCB 575 SI	RSI	EC
XJ	400 Diversion		91-94		MCB 640	SV		MCB 541		
XJR	400 R, S	4HM	94-99	*	MCB 640	SV		MCB 530	SH	
XS	400	2A2	77-82		MCB 68			MCB 68		
XS	400 DOHC	12E	82-84		MCB 524			MCS 958		
XS	400 SE	4G5	80-83		MCB 503			MCS 958		
XV	400 Virago		88-		MCB 587			MCS 957		
XVS	400 Drag Star		96		MCB 640	SV		MCS 957		
YFM	400 Big Bear 4WD	4SH	00-	*	MCB 510 SI			MCS 958		
YFM	400 Big Bear	4SH	03-04	*	MCB 510 SI			MCS 958		
YFM	400 Big Bear	4SH	05-06	*	MCB 510 SI			MCB 724 SI		



Option 1

Option 2

Option 3



Option 1

Option 2

Yamaha

YFM	400 Kodiak		93-99		MCS 844				MCS 958		
YFM	400 Kodiak 4WD	AJ03	00-02	*	MCB 510 SI				MCS 958		
YFM	400 Kodiak 4WD	AJ07	03-05	*	MCB 510 SI				MCS 958		
YFM	400 Kodiak 2WD	AJ08	03-04	*	MCB 510 SI				MCB 724 SI		
YFM	400 Grizzly		07-08	*	MCB 510 SI				MCB 724 SI		
YP	400 Majesty	SH02	04		MCB 640 SRM				MCB 768 SRM		
YP	400 Majesty	SH05	05-	*	MCB 666 SRM				MCB 768 SRM		
YP	400 Majesty ABS	SH05	08-	*	MCB 666 SRM				MCB 768 SRM		
YZ	400 F	CH01	98		MCB 669 SI	RSI	EC		MCB 625 SI	RSI	
YZ	400 F	CH03	99		MCB 669 SI	RSI	EC		MCB 575 SI	RSI	EC
IT	425		80						MCS 952		
WR	426 F	CJ02	01-02		MCB 669 SI	RSI	EC		MCB 575 SI	RSI	EC
YZ	426 F	CJ01	00-02		MCB 669 SI	RSI	EC		MCB 575 SI	RSI	EC
WR	450 F	CJ04	03-04		MCB 669 SI	RSI	EC		MCB 739 SI	RSI	EC
WR	450 F	CJ07	05		MCB 669 SI	RSI	EC		MCB 739 SI	RSI	EC
WR	450 F	CJ09	06		MCB 669 SI	RSI	EC		MCB 739 SI	RSI	EC
WR	450 F	CJ12	07		MCB 669 SI	RSI	EC		MCB 739 SI	RSI	EC
WR	450 F	CJ13	08-11		MCB 669 SI	RSI	EC		MCB 739 SI	RSI	EC
WR	450 F	DJ03	12-		MCB 669 SI	RSI	EC		MCB 739 SI	RSI	EC
YFM	450 Kodiak	AJ06	03-04	*	MCB 510 SI				MCB 724 SI		
YFM	450 Kodiak	AJ14	05-06	*	MCB 510 SI				MCB 724 SI		
YFM	450 Grizzly	AJ14/16/18	07-	*	MCB 510 SI				MCB 724 SI		
YFM	450 Grizzly IRS	AJ14	10-12	*	MCB 510 SI						
YFM	450 Grizzly EPS	AJ47/48/50	11-	*	MCB 510 SI						
YFM	450 Wolverine	AJ21/23	06-11	☒	MCB 582 SI						
YFM	450 Wolverine	AJ21/23	06-11	☒	MCB 615 SI				MCB 724 SI		
YFZ	450 T	AJ11	04-05	☒	MCB 582 SI						
YFZ	450 T	AJ11	04-05	☒	MCB 615 SI				MCB 561	SI	EC
YFZ	450	AJ20	06-09	☒	MCB 582 SI						
YFZ	450	AJ20	06-09	☒	MCB 615 SI				MCB 561	SI	EC
YFZ	450 R	AJ42	09-	☒	MCB 582 SI						
YFZ	450 R	AJ42	09-	☒	MCB 615 SI				MCB 561	SI	EC
YZ	450 F	CJ03/05	03-04		MCB 669 SI	RSI	EC		MCB 739 SI	RSI	EC
YZ	450 F	CJ06/10	05-07		MCB 669 SI	RSI	EC		MCB 739 SI	RSI	EC
YZ	450 F	CJ10	08-09		MCB 791 SI	RSI	EC		MCB 739 SI	RSI	EC
YZ	450 F	CJ15	10-		MCB 791 SI	RSI	EC		MCB 739 SI	RSI	EC
IT	465		81-82						MCS 955		
YZ	465	3R5	80						MCS 952		
YZ	465	4V4	81						MCS 955		
IT	490		84						MCS 955		
YZ	490	5X6/23X/43R	82-84						MCS 955		
YZ	490	57H/1LV/2HJ/2WH	85-88		MCB 549 SI				MCS 955		
RD	500 LC	47X/1GE	84-85	*	MCB 530				MCB 541		
SR	500	2J4	78-84		MCB 68				MCS 955		
SR	500	48T	85-87		MCB 68				MCS 955		
SR	500	48T	88-99		MCS 967				MCS 955		
WR	500	4AA	91-92		MCB 582 SI				MCB 625 SI		
XP	500 Tmax	SJ01	01-04		MCB 640 SRM				MCB 722 SRM		
XP	500 Tmax	SJ03	05-06	*	MCB 666 SRM				MCB 768 SRM		
XP	500 Tmax	SJ05	07	*	MCB 666 SRM				MCB 768 SRM		
XP	500 Tmax	SJ06	08-12	*	MCB 611 SRM				MCB 768 SRM		
XP	500 Tmax ABS	SJ06	08-12	*	MCB 611 SRM				MCB 768 SRM		
XT	500	1U6	76-82		MCS 952				MCS 955		
XT	500 Austria	1U6	83-85		MCB 524				MCS 955		
XT	500	1U6	86-89		MCB 539	SI	EC		MCS 955		
XV	500 SE	26R	83-84		MCB 524				MCS 950		
XP	530 Tmax Black Max	SJ09	12-	*	MCB 611 SRM				MCB 722 SRM		
XP	530 Tmax ABS	SJ09	12-	*	MCB 611 SRM				MCB 722 SRM		
XP	530 Tmax Iron Max ABS		15-	*	MCB 611 SRM				MCB 722 SRM		
XV	535 Virago	3BR/2YL	88-94		MCB 587				MCS 957		
XV	535 Virago	3BR/2YL	95-98		MCB 640	SV			MCS 957		
XV	535 DX Virago	VJ01	99-03		MCB 640	SV			MCS 957		
XJ	550	4V8	81-82	*	MCB 521				MCS 950		



* 2 Sätze erforderlich – 2 sets required
Parkbremse – Parkingbrake



ohne Verschleißanzeige – without wear indicator
linke Seite – left side
rechte Seite – right side



Option 1

Option 2

Option 3



Option 1

Option 2

Yamaha

XJ	550	4V8	83-84	*	MCB 524				MCS 950		
XT	550	5Y3	82-83		MCB 955				MCS 955		
XZ	550	11U	82-84	*	MCB 524				MCS 950		
YFM	550 Grizzly	AJ39	09-	☑	MCB 801 SI				MCB 803 SI		
YFM	550 Grizzly	AJ39	09-	☑	MCB 802 SI				MCB 804 SI		
YFM	550 Grizzly EPS	AJ41	09-11	☑	MCB 801 SI				MCB 803 SI		
YFM	550 Grizzly EPS	AJ41	09-11	☑	MCB 802 SI				MCB 804 SI		
YFM	550 Grizzly EPS	AJ53/54/58	12-	☑	MCB 801 SI				MCB 803 SI		
YFM	550 Grizzly EPS	AJ53/54/58	12-	☑	MCB 802 SI				MCB 804 SI		
FZ	600		86-87	*	MCB 530				MCB 530		
FZ6	600 N	RJ07	04-06	*	MCB 666	SV			MCB 634	SH	
FZ6	600 N	RJ14	07	*	MCB 666	SV			MCB 634	SH	
FZ6	600 NA ABS	RJ14	07	*	MCB 666	SV			MCB 634	SH	
FZ6	600 S Fazer	RJ07	04-06	*	MCB 666	SV			MCB 634	SH	
FZ6	600 S Fazer	RJ14	07-08	*	MCB 666	SV			MCB 634	SH	
FZ6	600 SA Fazer ABS	RJ07	06	*	MCB 666	SV			MCB 634	SH	
FZ6	600 SA Fazer ABS	RJ14	07-08	*	MCB 666	SV			MCB 634	SH	
FZ6-S2	600 N	RJ14	07-09	*	MCB 611	SV	SRQ		MCB 634	SH	
FZ6-S2	600 NA ABS	RJ14	07-10	*	MCB 611	SV	SRQ		MCB 634	SH	
FZ6-S2	600 S Fazer	RJ14	07-09	*	MCB 611	SV	SRQ		MCB 634	SH	
FZ6-S2	600 SA Fazer ABS	RJ14	07-10	*	MCB 611	SV	SRQ		MCB 634	SH	
FZR	600 H, M, N	3HE/3RG/3RH	89	*	MCB 530	SV			MCB 530	SH	
FZR	600 H, M, N	3HE/3RG/3RH	90-93	*	MCB 622	SV			MCB 530	SH	
FZR	600 R	4JH/4MH	94-95	*	MCB 622	SV			MCB 530	SH	
FZS	600 Fazer	RJ02	98-03	*	MCB 611	SV	SRQ		MCB 541	SH	
SRX	600 H, N	1XL/1XM/2TM	86-87	*	MCB 541				MCB 541		
SRX	600 H, N	1XL/1XM	88-89		MCB 559				MCB 541		
TT	600	36A	83-84						MCS 953		
TT	600	59X	85-88		MCB 539	SI	EC		MCS 968		
TT	600	59X	89		MCB 568	SV			MCS 953		
TT	600	3SW	90-92		MCB 549	SI			MCS 968		
TT	600 E, S Belgardia	4GV/4LW	93-95		MCB 648 SV	SI	RSI	EC	MCB 625 SI	RSI	
TT	600 E, S Belgardia	4GV/4LW	96-99		MCB 648 SV	SI	RSI	EC	MCB 672 SH	SI	EC
TT	600 R	DJ01	99-04		MCB 648 SV	SI	RSI	EC	MCB 672 SH	SI	EC
XJ	600 H, N	51J	84-90	*	MCB 530				MCB 530		
XJ	600 H, N	3KM/3KN	91	*	MCB 530	SV			MCB 530	SH	
XJ	600 N	4BR/4LX	94-97		MCB 640	SV			MCB 541	SH	
XJ	600 N	RJ01	98-03	*	MCB 666	SV			MCB 541	SH	
XJ	600 S Diversion	4BR	92-97		MCB 640	SV			MCB 541	SH	
XJ	600 S Diversion	4LX	94-97		MCB 640	SV			MCB 541	SH	
XJ	600 S Diversion	RJ01	98-03	*	MCB 666	SV			MCB 541	SH	
XJ6	600 F Diversion	RJ19	09-12	*	MCB 666	SV			MCB 585	SH	
XJ6	600 FA Diversion ABS	RJ19	09-12	*	MCB 666	SV			MCB 585	SH	
XJ6	600 F Diversion	RJ22	13-	*	MCB 666	SV			MCB 585	SH	
XJ6	600 FA Diversion ABS	RJ22	13-	*	MCB 666	SV			MCB 585	SH	
XJ6	600 N	RJ19	09-12	*	MCB 666	SV			MCB 585	SH	
XJ6	600 NA ABS	RJ19	09-12	*	MCB 666	SV			MCB 585	SH	
XJ6	600 N	RJ22	13-	*	MCB 666	SV			MCB 585	SH	
XJ6	600 NA ABS	RJ22	13-	*	MCB 666	SV			MCB 585	SH	
XJ6	600 S Diversion	RJ19	09-12	*	MCB 666	SV			MCB 585	SH	
XJ6	600 SA Diversion ABS	RJ19	09-12	*	MCB 666	SV			MCB 585	SH	
XJ6	600 S Diversion	RJ22	13-	*	MCB 666	SV			MCB 585	SH	
XJ6	600 SA Diversion ABS	RJ22	13-	*	MCB 666	SV			MCB 585	SH	
XJ6	600 SP ABS	RJ22	13-	*	MCB 666	SV			MCB 585	SH	
XT	600 H, N	43F	83-86		MCB 524				MCS 955		
XT	600 H, N	2NF/2KF	87-90		MCB 568				MCB 539	EC	
XT	600 E	3TB/3UW	90-98		MCB 627	SV			MCB 539	EC	
XT	600 E	DJ02	99-03		MCB 627	SV			MCB 539	EC	
XT	600 K	3TB/3UW	91-95		MCB 627	SV			MCB 539	EC	
XT	600 Z Tenere	34L/55W	83-85		MCB 524				MCS 955		
XT	600 Z Tenere	1VJ	86-87		MCB 568	SV			MCS 955		
XT	600 Z Tenere	3AJ	88-91		MCB 568	SV			MCB 539	EC	
YFM	600 FWA Grizzly 4x4	AJ02	98-01	*	MCB 561 SI	EC			MCS 958		
YZF	600 R6	RJ03	99-02	*	MCB 611 SV	SRQ	CRQ	SCR	MCB 699	SH	
YZF	600 R6	RJ05	03	*	MCB 611 SV	SRQ	CRQ	SCR	MCB 634	SH	



Option 1

Option 2

Option 3



Option 1

Option 2

Yamaha

YZF	600 R6	RJ09	04-05	*	MCB 611 SV	SRQ	CRQ	SCR	MCB 634	SH
YZF	600 R6	RJ11	06-07	*	MCB 611 SV	SRQ	CRQ	SCR	MCB 634	SH
YZF	600 R6	RJ15	08-	*	MCB 611 SV	SRQ	CRQ	SCR	MCB 634	SH
YZF	600 R Thunder Cat	4TV/4WD	96-02	*	MCB 611 SV	SRQ	CRQ		MCB 530	SH
XJ	650 H, N	4K0	80-85	*	MCB 68				MCS 957	
XJ	650 Turbo	11T	82-84	*	MCB 524				MCS 957	
XS	650	447	75-76	*	MCB 44				MCS 954	
XS	650	447	77-83		MCB 68				MCS 954	
XS	650 SE Custom	3L1	79-80		MCB 68				MCS 954	
XS	650 SE Special	3L1	81-83		MCB 68				MCB 68	
XVS	650 Drag Star	4XR/4VR	97-00		MCB 640	SV			MCS 957	
XVS	650 Drag Star	VM03	01-04		MCB 640	SV			MCS 957	
XVS	650 Drag Star classic	VM02	98-00		MCB 640	SV			MCS 957	
XVS	650 Drag Star classic	VM03	01-03		MCB 640	SV			MCS 957	
XVS	650 Drag Star classic	VM04	04-07		MCB 640	SV			MCS 957	
MT-03	660 H, N	RM02	06-	*	MCB 666	SV			MCB 672	SH
SZR	660	4SU	95-98		MCB 540	SV			MCB 75	
XT	660 R	DM01	04-		MCB 671	SV			MCB 672	SH
XT	660 X	DM01	04-		MCB 683	SV			MCB 672	SH
XT	660 Z Tenere	DM02	08-12	*	MCB 648	SV			MCB 672	SH
XT	660 Z Tenere	DM04	13-	*	MCB 648	SV			MCB 672	SH
XT	660 ZA Tenere ABS	DM04	13-	*	MCB 648	SV			MCB 672	SH
XTZ	660 Tenere	4YF	91-99		MCB 627	SV			MCB 539	EC
YFM	660 FWA Grizzly 4x4	AM03	02-08	*	MCB 561 SI				MCB 756 SI	
YFM	660 R Raptor	AM01	01-05	*	MCB 561 SI				MCB 561 SI	
YXR	660 Rhino		04-06		MCB 582 SI				MCB 723 SI	
YXR	660 Rhino		04-06		MCB 615 SI				MCB 723 SI	
MT-07	700	RM04	14-	*	MCB 611	SV	SRQ		MCB 634	SH
MT-07	700 Moto Cage, Moto Cage ABS		15-	*	MCB 611	SV	SRQ		MCB 634	SH
YFM	700 FWAD Grizzly EPS	AM09	07-		MCB 801 SI				MCB 803 SI	
YFM	700 FWAD Grizzly EPS	AM09	07-		MCB 802 SI				MCB 804 SI	
YFM	700 R Raptor	AM07	06-		MCB 582 SI				MCB 723 SI	
YFM	700 R Raptor	AM07	06-		MCB 615 SI				MCB 723 SI	
YXR	700 Rhino		09		MCB 582 SI				MCB 582 SI	
YXR	700 Rhino		09		MCB 615 SI				MCB 582 SI	
FZ	750	1FN	85-86	*	MCB 530				MCB 530	
FZ	750 Genesis	2KK	87-88	*	MCB 530				MCB 530	
FZ	750 Genesis	2KK	89-91	*	MCB 559	SV			MCB 530	SH
FZ	750 Genesis	3KT	91-94	*	MCB 559	SV			MCB 530	SH
FZR	750 R (0W01)	3PJ	89-93	*	MCB 595	SV	SRQ	CRQ	MCB 530	SH
FZR	750 RT Genesis	2TT	86-88	*	MCB 584				MCB 530	
FZX	750 Fazer	2JE	86-89	*	MCB 530				MCB 530	
XJ	750	41Y	82-85		MCB 521				MCS 957	
XJ	750 Seca	11M	81-84	*	MCB 521				MCS 957	
XS	750	1T5	77-80	*	MCB 68				MCB 68	
XS	750 SE Custom	3L3	80-82		MCB 520				MCB 68	
XS	750 SE Custom	3L3	80-82		MCB 503					
XTZ	750 H,N Super Tenere	3LD/3WM	89-97		MCB 582	SV	SI		MCB 604	
XTZ	750 H,N Super Tenere	3LD/3WM	89-97		MCB 615	SV	SI			
XV	750	4FY	89-92		MCB 530				MCS 957	
XV	750 SE	5G5	81-82		MCB 520				MCS 950	
XV	750 Virago	4FY	92-94	*	MCB 559	SV			MCS 950	
XV	750 Virago	4PW	94-98	*	MCB 640	SV			MCS 957	
YZF	750 R, SP	4HN/4HT	93-98	*	MCB 656 SV	SRQ			MCB 530	SH
YZF	750 R7 (0W02)	RM01	99-01	*	MCB 611 SV	SRQ	CRQ		MCB 702	SH
FZ8	800 S Fazer	RN25	10-	*	MCB 611	SV	SRQ	CRQ	MCB 634	SH
FZ8	800 SA Fazer ABS	RN25	10-	*	MCB 611	SV	SRQ	CRQ	MCB 634	SH
FZ8	800 N	RN25	10-	*	MCB 611	SV	SRQ	CRQ	MCB 634	SH
FZ8	800 NA ABS	RN25	10-	*	MCB 611	SV	SRQ	CRQ	MCB 634	SH
MT-09	850	RN29	13-	*	MCB 611	SV	SRQ		MCB 634	SH
MT-09	850 ABS	RN29	13-	*	MCB 611	SV	SRQ		MCB 634	SH
MT-09	850 Tracer ABS		15-	*	MCB 611	SV	SRQ		MCB 634	SH
TDM	850 H, N	3VD/4CM	91-96	*	MCB 559	SV			MCB 530	SH



* 2 Sätze erforderlich – 2 sets required
Parkbremse – Parkingbrake



ohne Verschleißanzeige – without wear indicator
linke Seite – left side
rechte Seite – right side



Option 1

Option 2

Option 3



Option 1

Option 2

Yamaha

TDM	850	4TX	96-01		*	MCB 622	SV			MCB 530	SH
TRX	850	4UN	96-	Brembo	*	MCB 683	SV			MCB 530	SH
TRX	850	4UN	96-	Sumitomo	*	MCB 584	SV			MCB 530	SH
XS	850	400	80-81		*	MCB 68				MCB 68	
XS	850	4H1	81-		☑	MCB 520					
XS	850	4H1	81-		☑	MCB 503				MCB 68	
TDM	900	RN08	02-03		*	MCB 611	SV			MCB 731	SH
TDM	900	RN11	04-06		*	MCB 611	SV			MCB 731	SH
TDM	900 A ABS	RN11	05-06		*	MCB 611	SV			MCB 731	SH
TDM	900 A ABS	RN18	07-		*	MCB 611	SV			MCB 731	SH
XJ	900	31A	83-84		*	MCB 530				MCB 530	
XJ	900	58L	85-86		*	MCB 530				MCB 530	
XJ	900 F	58L	85-90		*	MCB 530				MCB 530	
XJ	900 F	4BB	91-94		*	MCB 530				MCB 530	
XJ	900 S Diversion	4KM	95-03		*	MCB 640	SV			MCB 530	SH
XV	950 ABS	VN03	13-			MCB 640	SV			MCB 731	SH
XV	950 R ABS	VN03	13-			MCB 640	SV			MCB 731	SH
XVS	950 A Midnight Star	VN02	09-			MCB 640	SV			MCB 731	SH
FZ1	1000 N	RN16	06-		*	MCB 611	SV	SRQ		MCB 634	SH
FZ1	1000 NA ABS	RN16	08-		*	MCB 611	SV	SRQ		MCB 634	SH
FZ1	1000 S Fazer	RN16	06-		*	MCB 611	SV	SRQ		MCB 634	SH
FZ1	1000 SA Fazer ABS	RN16	08-		*	MCB 611	SV	SRQ		MCB 634	SH
FZR	1000 Genesis	2LA	87-88		*	MCB 584				MCB 530	
FZR	1000 Genesis Exup	3LE	89-90		*	MCB 622	SV			MCB 530	SH
FZR	1000 Genesis Exup	3LE	91-93		*	MCB 642	SV			MCB 530	SH
FZR	1000 Genesis Exup	3LE	94-95		*	MCB 656 SV	SRQ			MCB 530	SH
FZS	1000 Fazer	RN06	01-04		*	MCB 611	SV	SRQ		MCB 725	SH
FZS	1000 S Fazer	RN06	03-04		*	MCB 611	SV	SRQ		MCB 725	SH
FZS	1000 Fazer	RN14	05		*	MCB 611	SV	SRQ		MCB 725	SH
FZS	1000 S Fazer	RN14	05		*	MCB 611	SV	SRQ		MCB 725	SH
GTS	1000	4BH	93-95			MCB 655				MCB 530	SH
GTS	1000 A ABS	4BH	93-00			MCB 655				MCB 530	SH
XV	1000 SE Midnight Special	23W	83-85		*	MCB 521				MCS 957	
XV	1000 TR1	5A8	81		*	MCB 68				MCS 957	
XV	1000 Virago	2AE	86-87		*	MCB 530				MCS 957	
YZF	1000 R1	RN01	98-99		*	MCB 611 SV	CRQ	SRQ	SCR	MCB 702	SH
YZF	1000 R1	RN04	00-01		*	MCB 611 SV	CRQ	SRQ	SCR	MCB 702	SH
YZF	1000 R1	RN09	02-03		*	MCB 611 SV	CRQ	SRQ	SCR	MCB 699	SH
YZF	1000 R1	RN12	04-06		*	MCB 611 SV	CRQ	SRQ	SCR	MCB 634	SH
YZF	1000 R1	RN19	07-08		4☐ *	MCB 795 SV	SRQ	CRQ	SCR	MCB 634	SH
YZF	1000 R1	RN22	09-14		4☐ *	MCB 795 SV	SRQ	CRQ	SCR	MCB 634	SH
YZF	1000 R1 ABS		15-		*	MCB 611 SV	CRQ	SRQ	SCR	MCB 784 SH	
YZF	1000 R1M ABS		15-		*	MCB 611 SV	CRQ	SRQ	SCR	MCB 784 SH	
YZF	1000 Thunder Ace	4VD	96-02		*	MCB 611 SV	CRQ	SRQ		MCB 530	SH
BT	1100 Bulldog	RP05	02-06		*	MCB 611	SV	SRQ		MCB 530	SH
FJ	1100	47E	83-85		*	MCB 530				MCB 530	
XS	1100	2H9	78-81		*	MCB 68				MCB 68	
XS	1100 S	5K7	81-82		*	MCB 521				MCB 68	
XV	1100 Virago	3LP	86-93		*	MCB 530	SV			MCS 957	
XV	1100 Virago	3LP	94-98		*	MCB 640	SV			MCS 957	
XV	1100 Virago	3LP	99		*	MCB 666	SV			MCB 530	SH
XVS	1100 Drag Star	VP05	99-04		*	MCB 666	SV			MCB 530	SH
XVS	1100 Drag Star Classic	VP05	00-02		*	MCB 666	SV			MCB 530	SH
XVS	1100 Drag Star Classic	VP16	03-07		*	MCB 666	SV			MCB 530	SH
FJ	1200	1XJ	86-87		*	MCB 530				MCB 530	
FJ	1200	3CW	88-90		*	MCB 559	SV			MCB 530	
FJ	1200	3YA	91-97		*	MCB 559	SV			MCB 530	
FJ	1200 A ABS	3YA	91-95		*	MCB 584	SV			MCB 530	SH
VMX	1200 V-Max	1FK/1JH	85-87		*	MCB 530				MCB 530	
VMX	1200 V-Max	2WE/2WF	88-92		*	MCB 530	SV			MCB 530	SH
VMX	1200 V-Max	2WE/2WF	93-95		*	MCB 622	SV			MCB 530	SH
VMX	1200 V-Max	EN/LT	96-98		*	MCB 622	SV			MCB 530	SH
VMX	1200 V-Max	VP03	99-02		*	MCB 622	SV			MCB 530	SH
XJR	1200	4PU	96-98	Sumitomo	*	MCB 584	SV			MCB 530	SH
XJR	1200	4PU	94-98	Brembo	*	MCB 683	SV			MCB 530	SH



Option 1

Option 2

Option 3



Option 1

Option 2

Yamaha

XT	1200 Z Super Tenere ABS	DP01	10-		*	MCB 611	SV			MCB 731	SH
XT	1200 ZE Super T. Worldcrosser ABS	DP04	12-		*	MCB 611	SV			MCB 731	SH
XVZ	1200 TD Venture Royale	47G	84-85		*	MCB 530				MCB 530	
FJR	1300	RP04	01-04		*	MCB 611	SV			MCB 731	SH
FJR	1300 A ABS	RP08	03		*	MCB 611	SV			MCB 731	SH
FJR	1300 A ABS	RP11	04-05		*	MCB 611	SV			MCB 731	SH
FJR	1300 A ABS	RP13	06-12	4 ☐	*	MCB 706	SV			MCB 731	SH
FJR	1300 A ABS	RP23	13-	4 ☐	*	MCB 706	SV			MCB 731	SH
FJR	1300 AS ABS	RP13	06-12	4 ☐	*	MCB 706	SV			MCB 731	SH
FJR	1300 AS ABS	RP23	13-	4 ☐	*	MCB 706	SV			MCB 731	SH
XJR	1300 SP	RP02	99-01		*	MCB 611	SV	SRQ	CRQ	MCB 530	SH
XJR	1300	RP06	02-03		*	MCB 611	SV	SRQ	CRQ	MCB 725	SH
XJR	1300	RP10	04-06		*	MCB 611	SV	SRQ	CRQ	MCB 725	SH
XJR	1300	RP19	07-14		*	MCB 611	SV	SRQ	CRQ	MCB 725	SH
XJR	1300		15-		*	MCB 611	SV	SRQ	CRQ	MCB 725	SH
XJR	1300 Racer		15-		*	MCB 611	SV	SRQ	CRQ	MCB 725	SH
XVS	1300 A Midnight Star	VP26	07-		*	MCB 666	SV			MCB 731	SH
XVS	1300 Custom	VP36	14-			MCB 666	SV			MCB 731	SH
XVZ	1300 A Royale Star	4YP	96-00		*	MCB 584	SV			MCB 559	
XVZ	1300 AT Royal Star Tour Classic	4NL	97-00		*	MCB 584	SV			MCB 559	
XVZ	1300 Royal Star Boulevard	VP09	99-01		*	MCB 584	SV			MCB 559	
XVZ	1300 TF Royal Star Venture	VP09	99-01		*	MCB 640	SV			MCB 559	
XVZ	1300 TD Venture Royal	3JS	86-92		*	MCB 584	SV			MCB 559	
	1300 Stryker		11-			MCB 640	SV			MCB 731	SH
XV	1600 A Wild Star	VP08	99-04		*	MCB 640	SV			MCB 559	
	1700 V-Max ABS	RP21	09-	4 ☐	*	MCB 795 SV	SRQ	CRQ		MCB 731	SH
MT-01	1700	RP12	05-06		*	MCB 611	SV	SRQ		MCB 631	SH
MT-01	1700	RP18	07-12	4 ☐	*	MCB 795 SV	SRQ	CRQ		MCB 631	SH
XV	1700 Road Star Warrior	VP14	03-05		*	MCB 611	SV			MCB 731	SH
XV	1900 A Midnight Star	VP23	06-		*	MCB 611	SV			MCB 731	SH

Zhongyu

ZY	50 QT					MCB 590	EC				
----	-------	--	--	--	--	---------	----	--	--	--	--

Zündapp

KS	50 Supersport		-79			MCB 508					
KS	50 TT Watercooled		80-81			MCB 508					
KS	80		80			MCB 508					
KS	80 Super		80-			MCB 552					
KS	80 Super		83-			MCB 536					
KS	80 Touring		81-			MCB 508					
KS	125		79			MCB 536					
KS	175		78-			MCB 16					



* 2 Sätze erforderlich – 2 sets required
Parkbremse – Parkingbrake



ohne Verschleißanzeige – without wear indicator



linke Seite – left side



rechte Seite – right side



MCB14

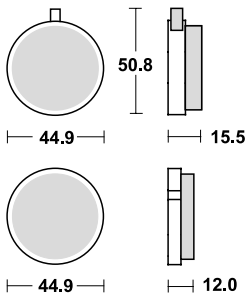

MCB16

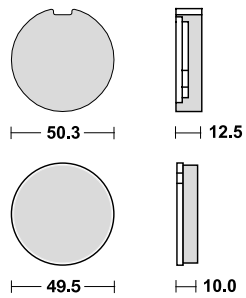

MCB17

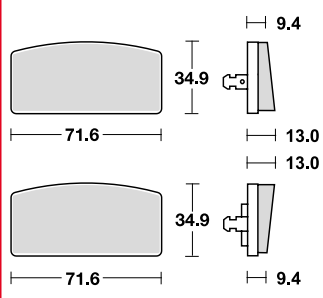

MCB18

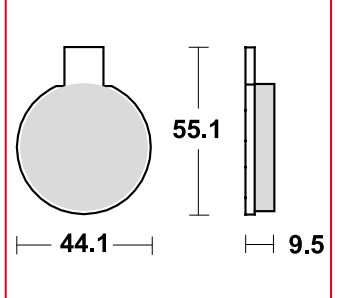

MCB19

SV RQ

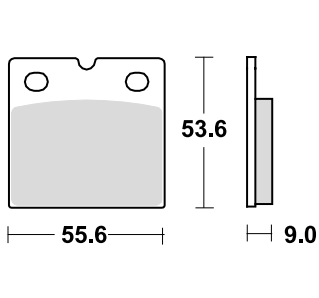

MCB32

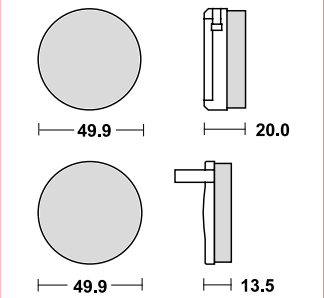

MCB35

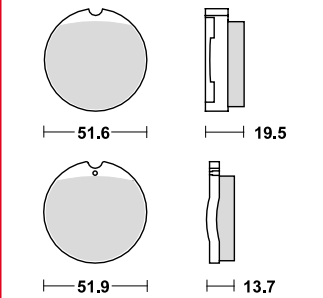

MCB44

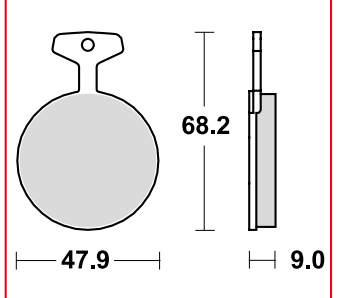

MCB501

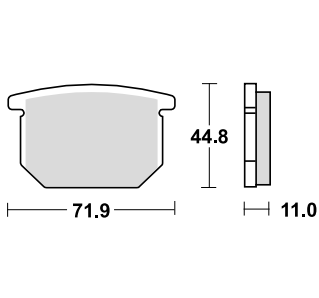

MCB502

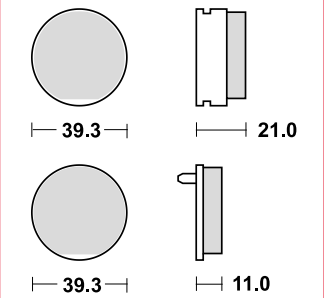

MCB503

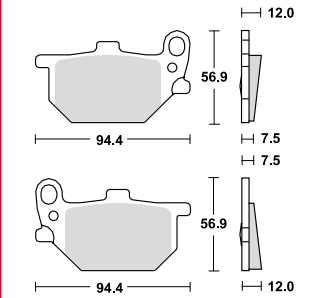

MCB504

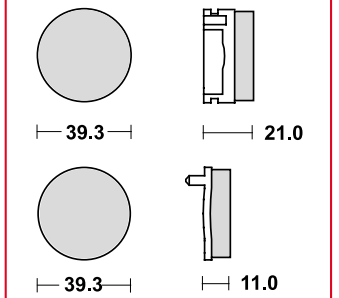

MCB505

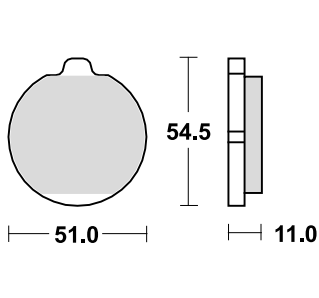

MCB506

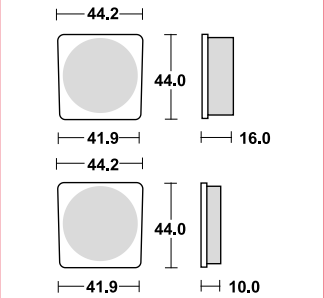

MCB507

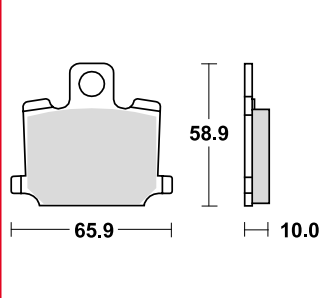

MCB508

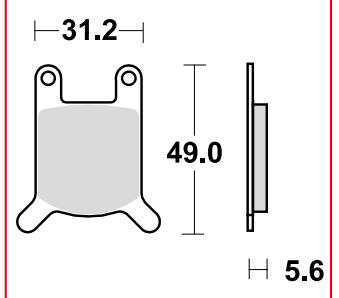

MCB509

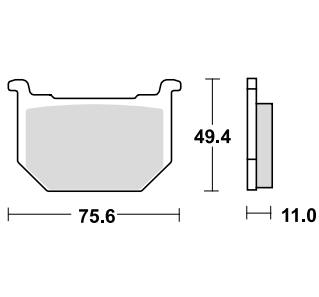

MCB510

SI

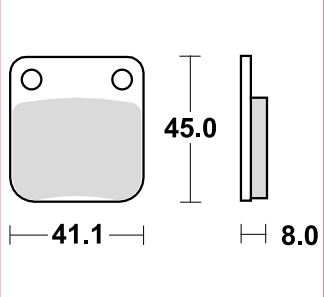

MCB511

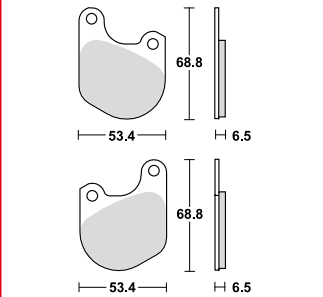

MCB512

SV SH

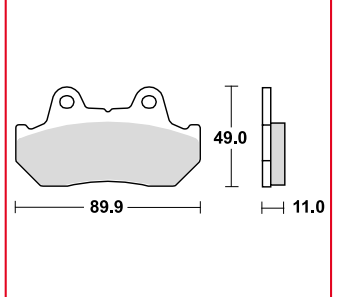

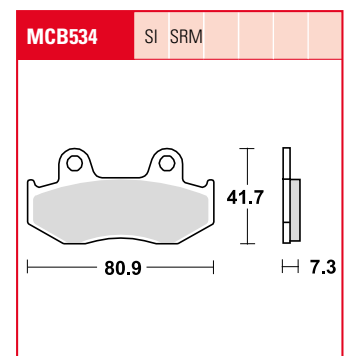
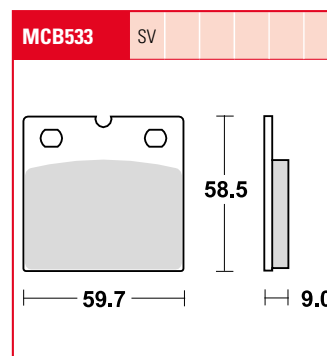
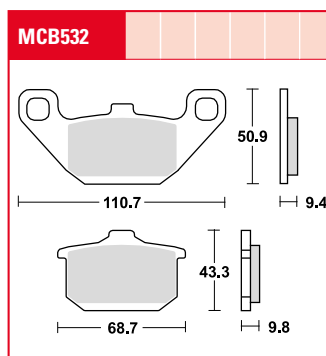
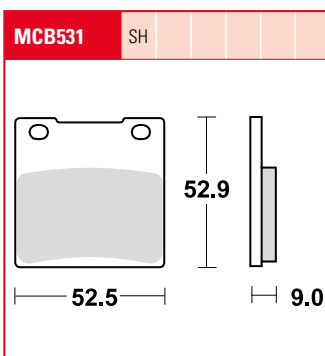
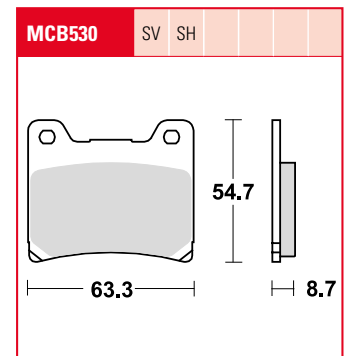
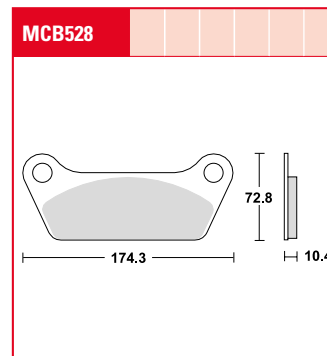
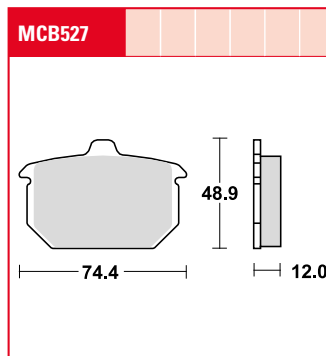
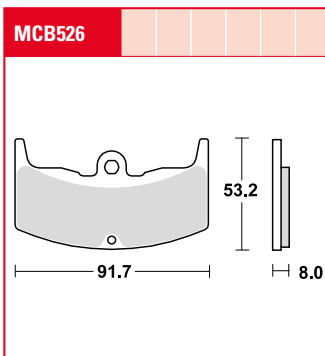
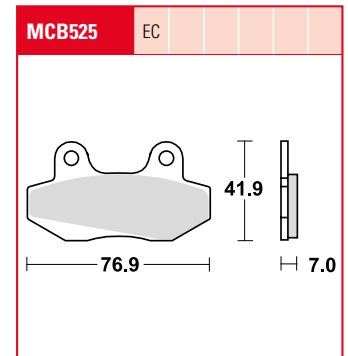
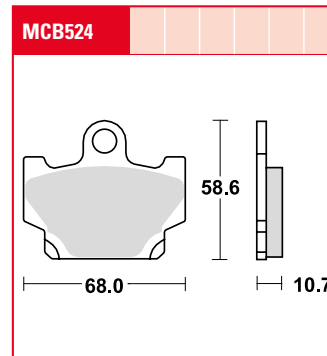
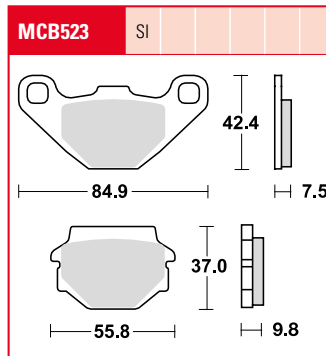
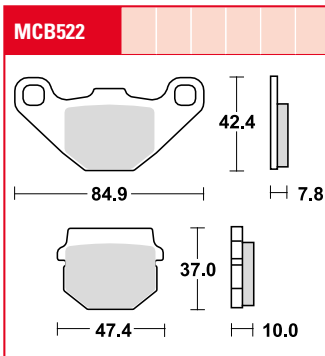
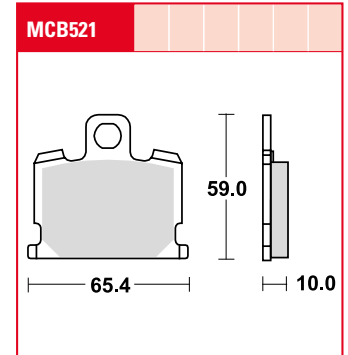
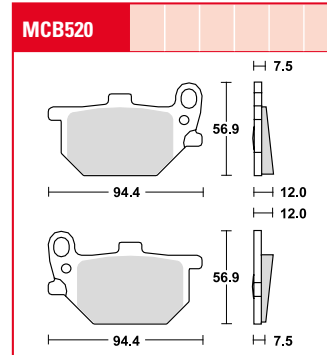
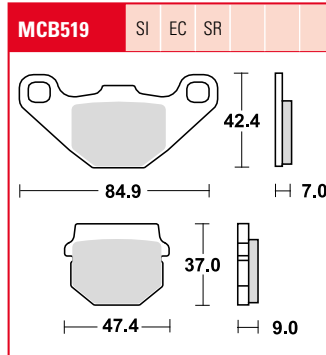
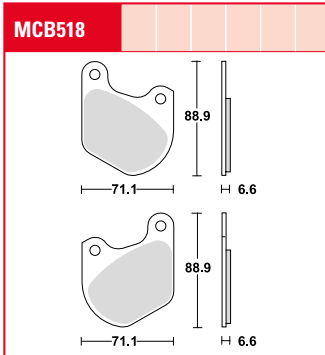
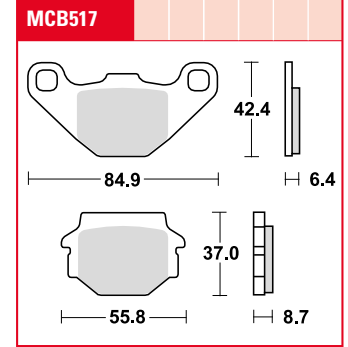
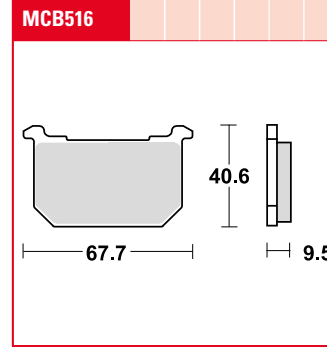
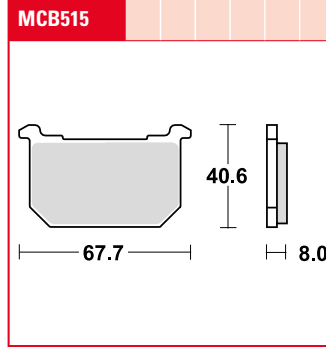
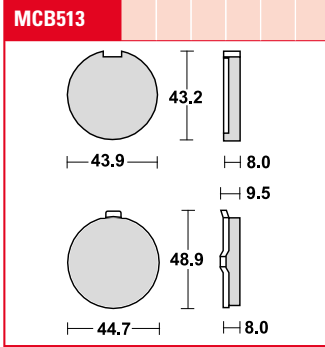

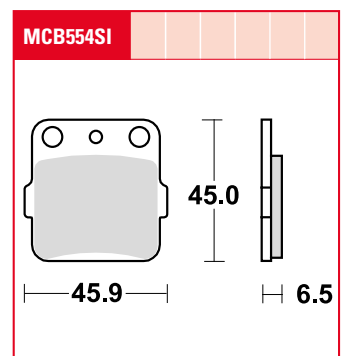
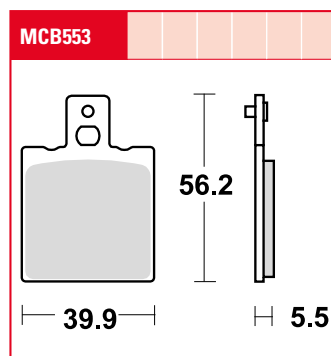
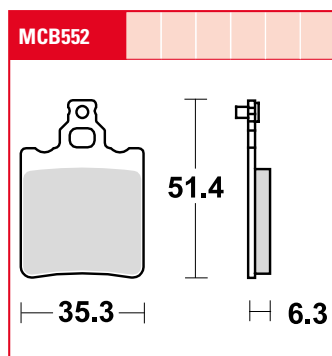
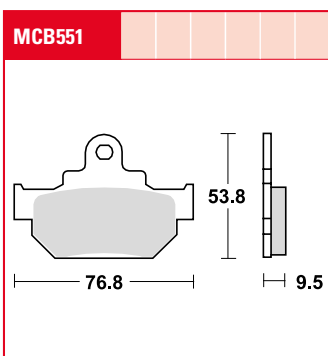
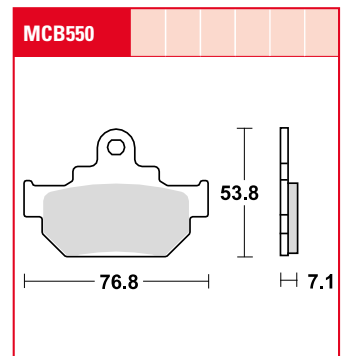
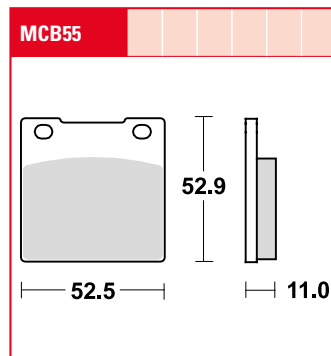
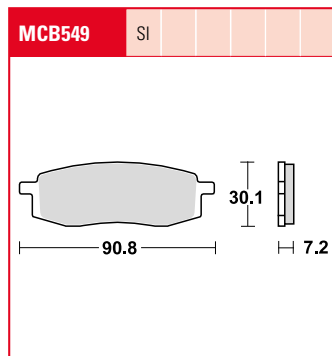
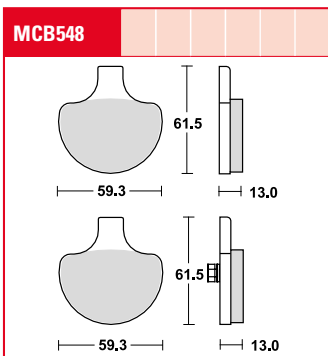
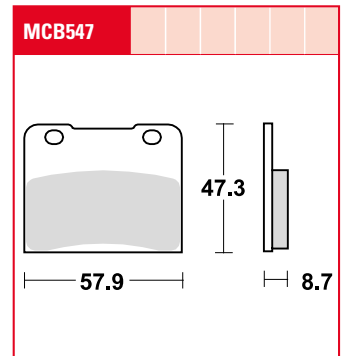
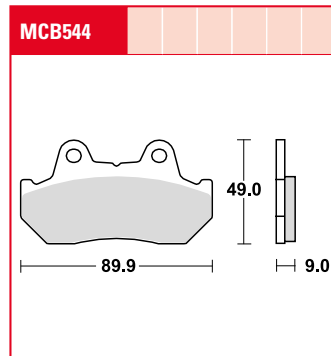
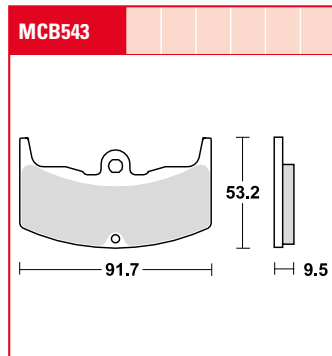
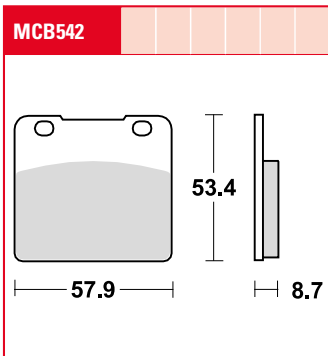
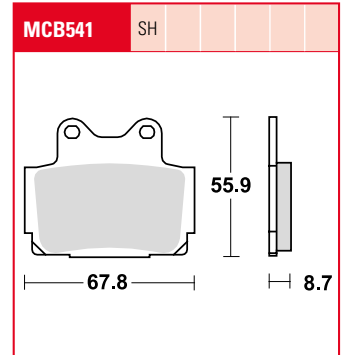
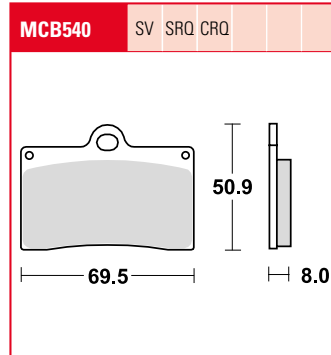
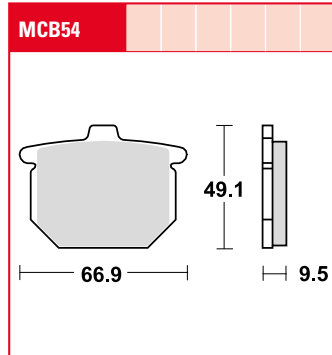
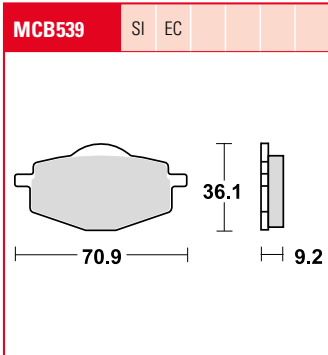
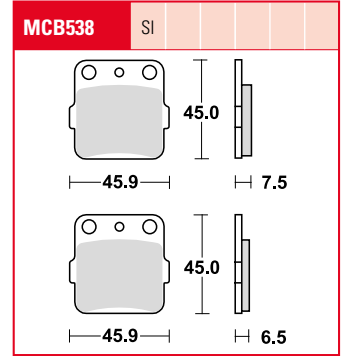
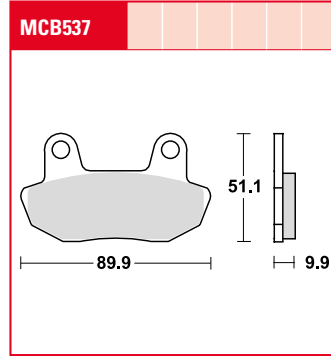
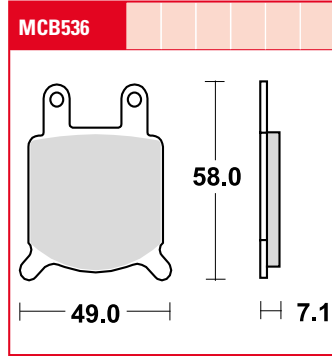
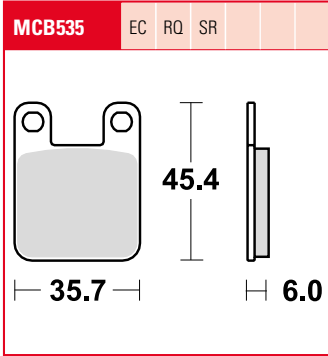

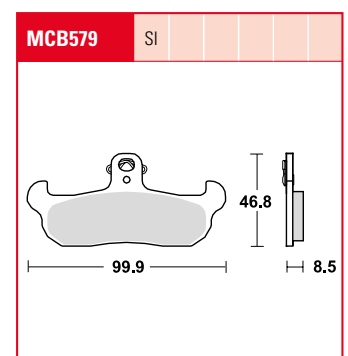
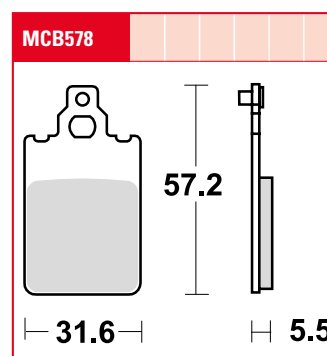
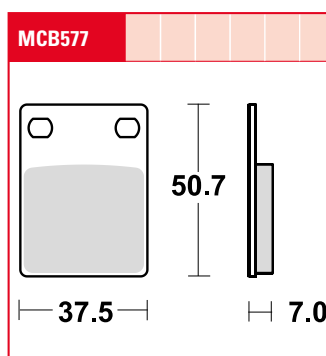
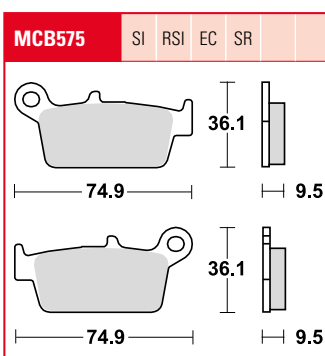
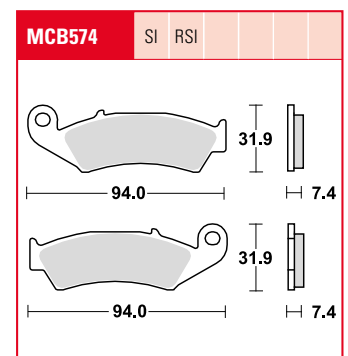
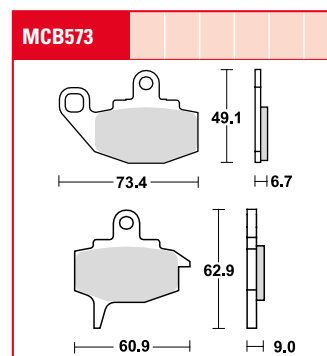
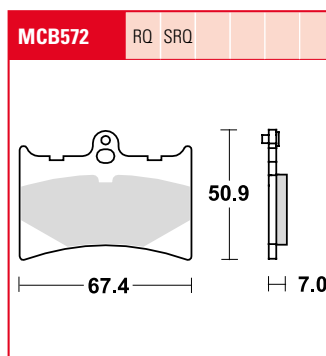
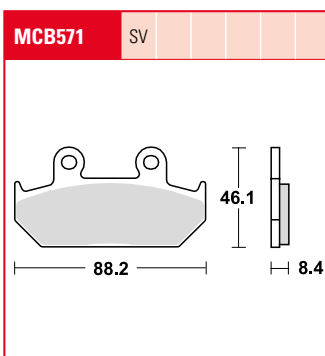
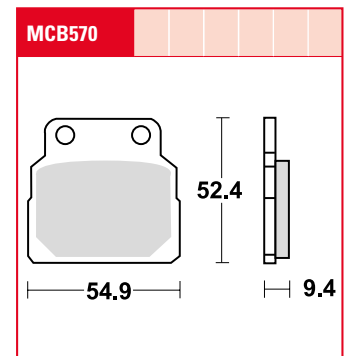
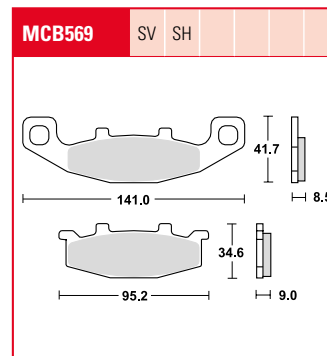
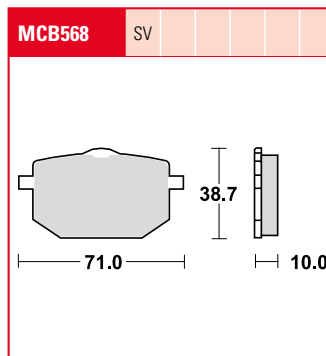
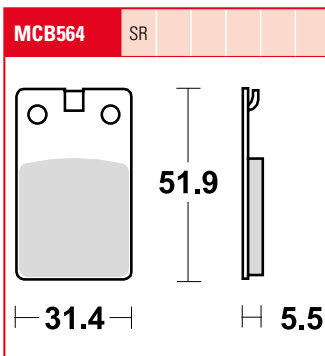
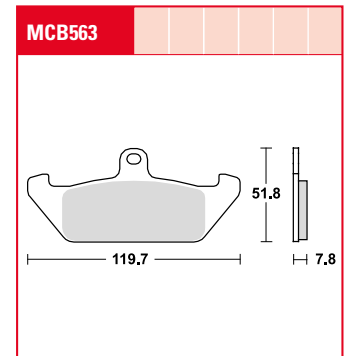
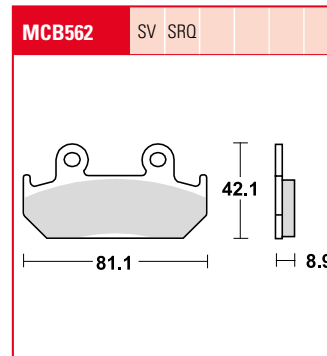
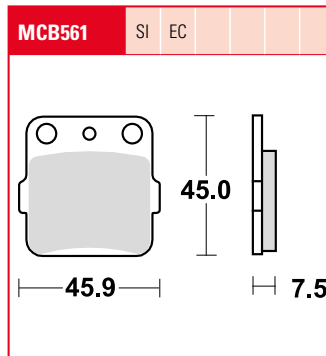
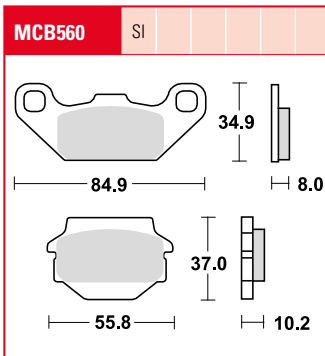
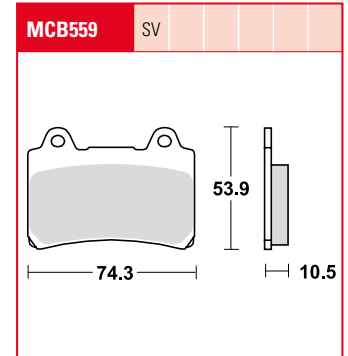
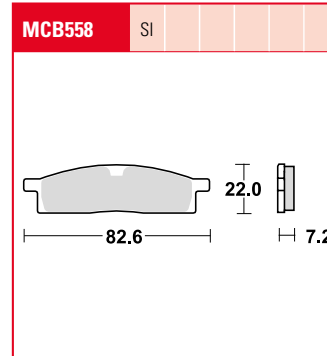
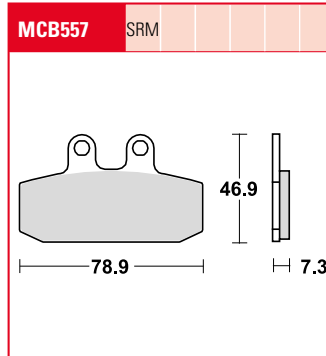
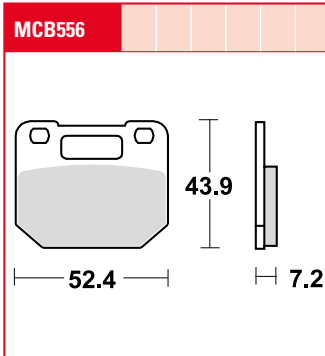

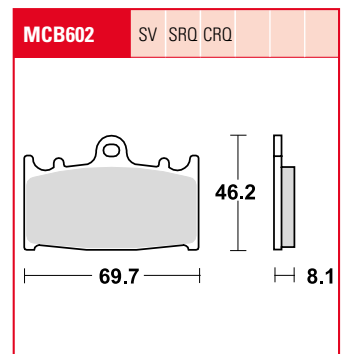
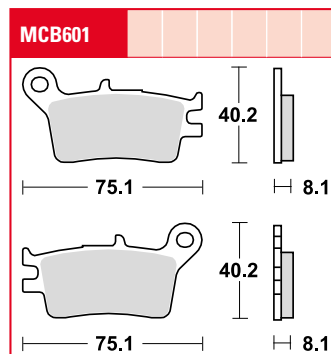
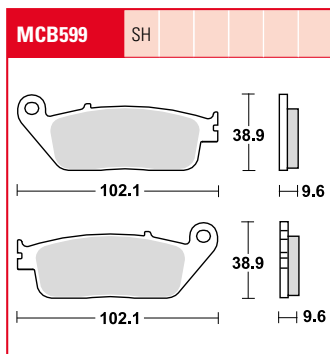
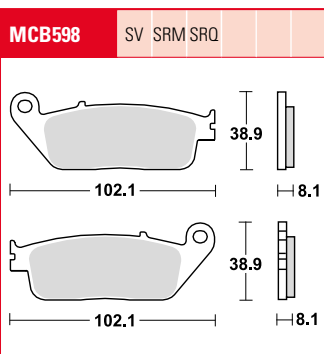
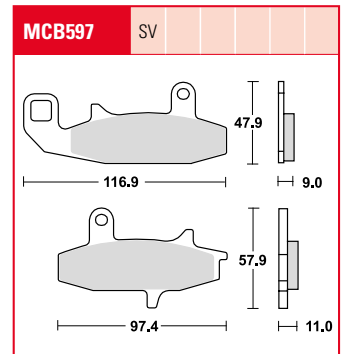
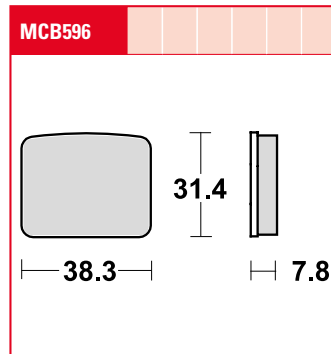
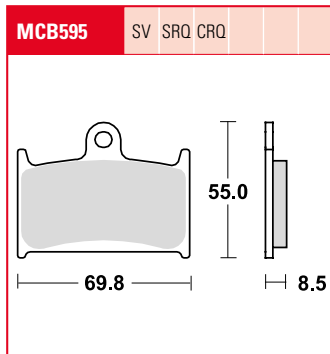
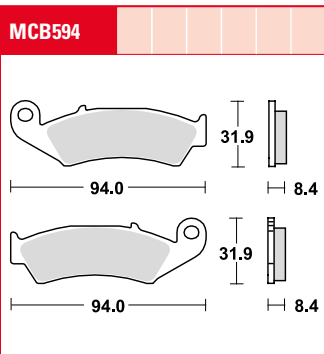
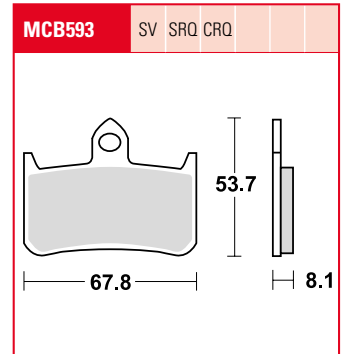
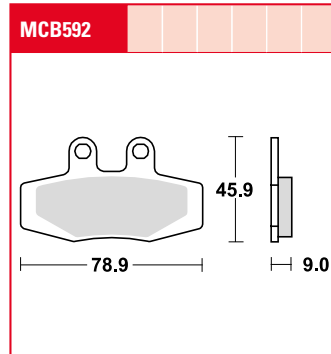
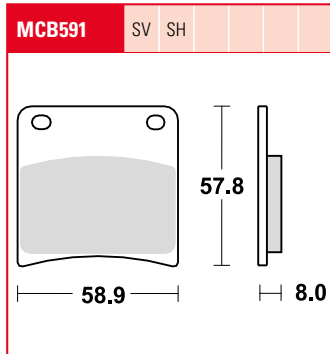
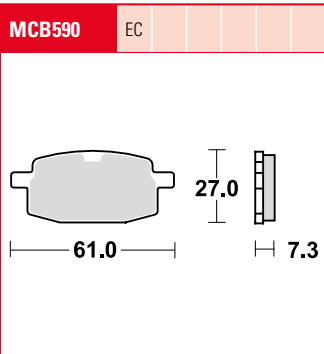
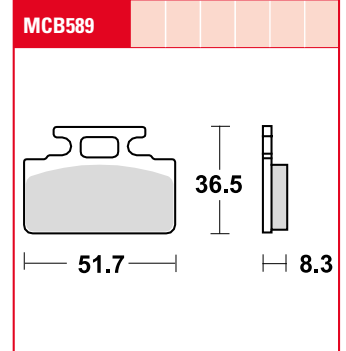
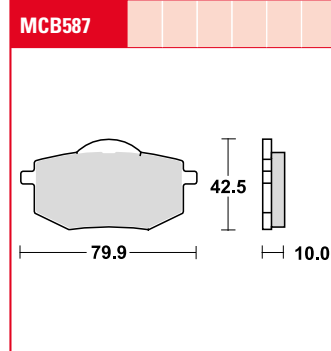
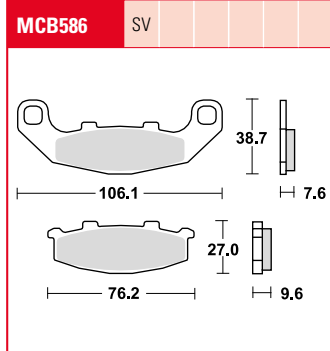
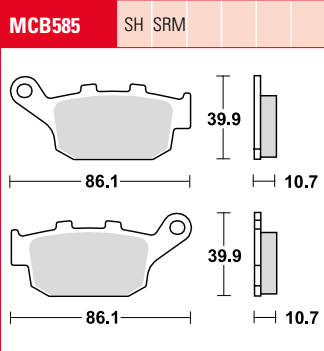
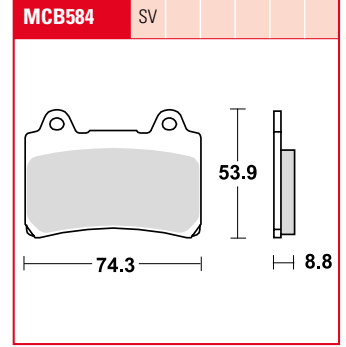
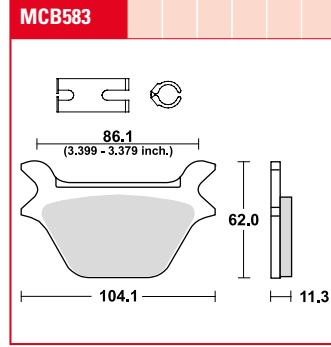
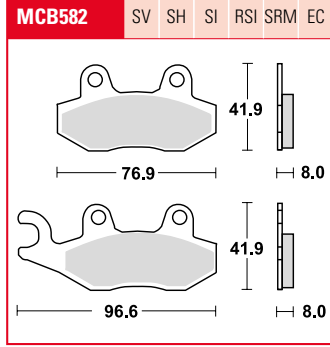
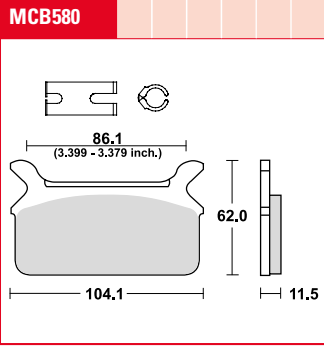

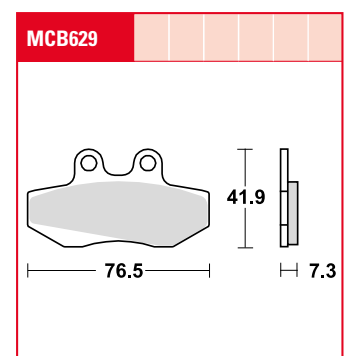
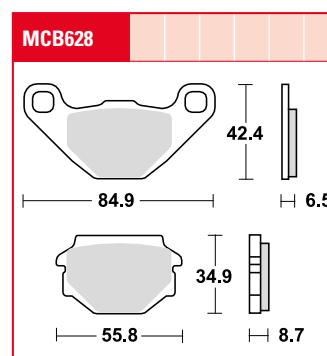
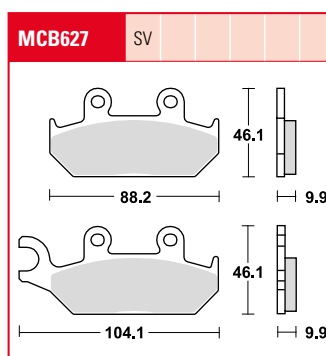
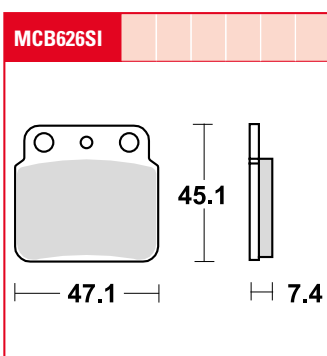
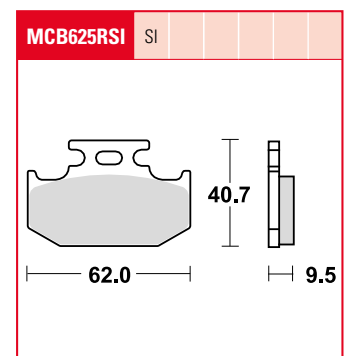
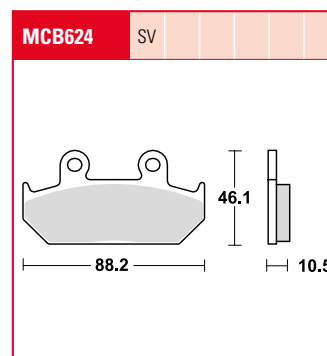
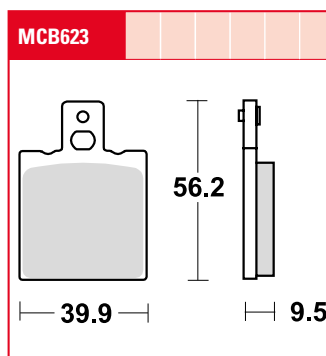
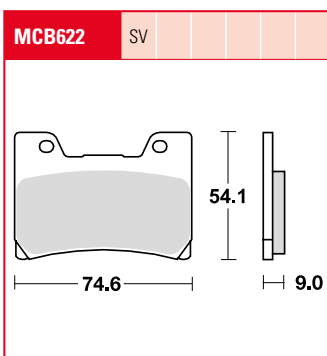
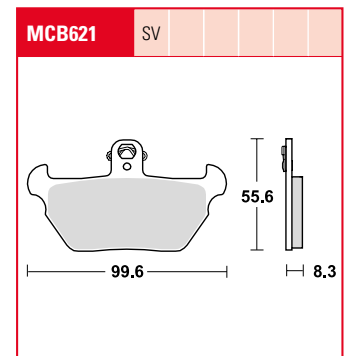
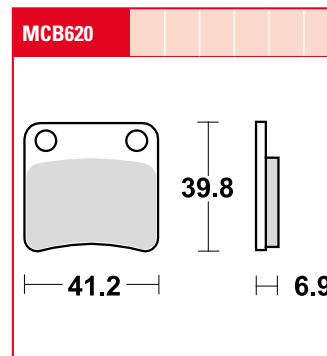
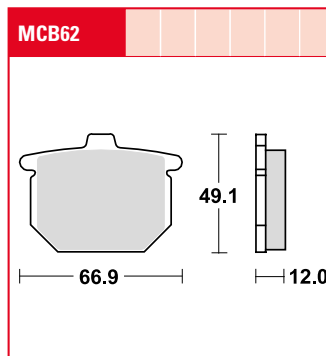
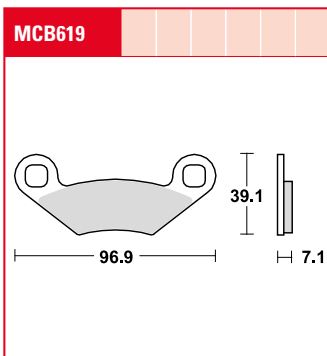
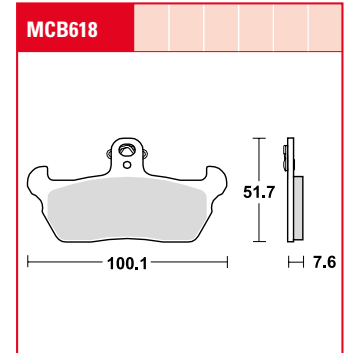
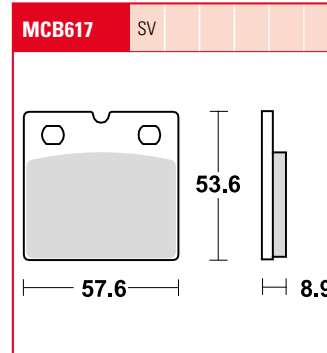
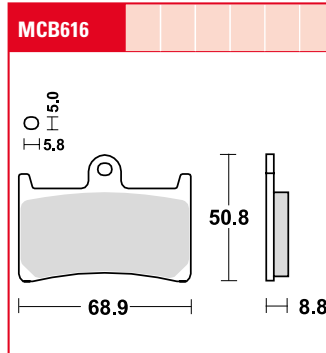
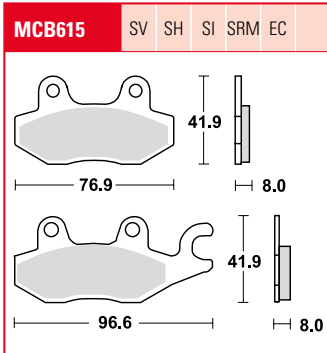
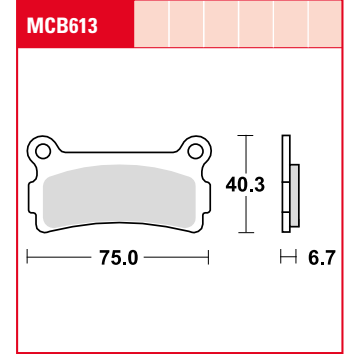
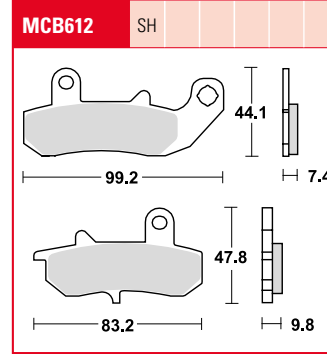
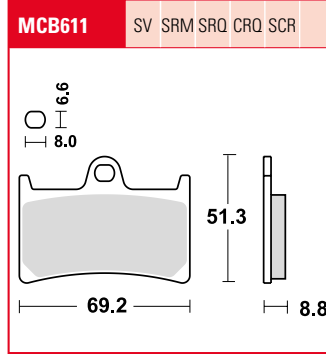
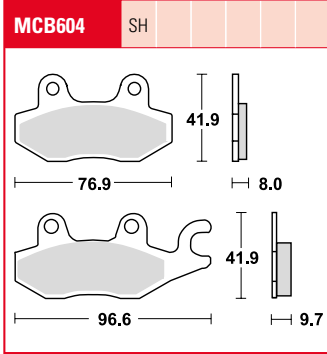

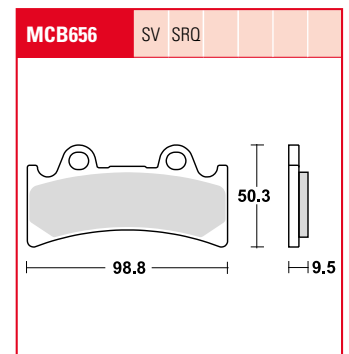
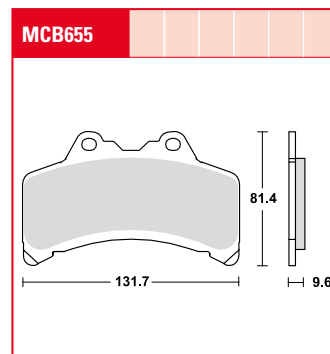
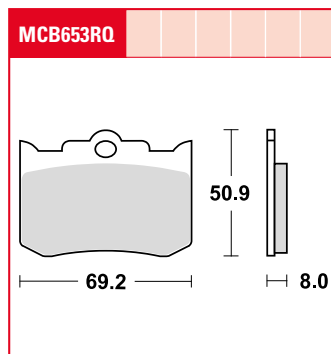
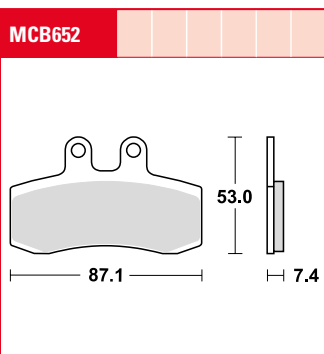
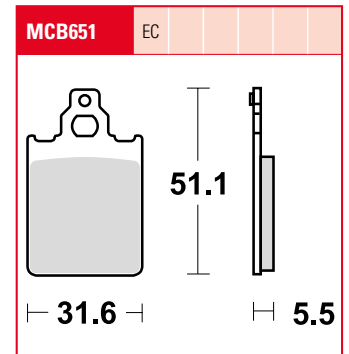
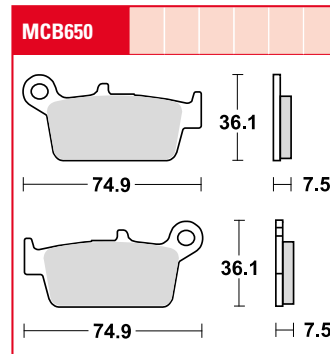
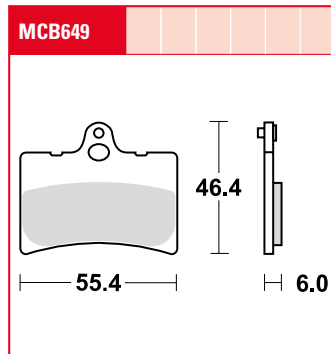
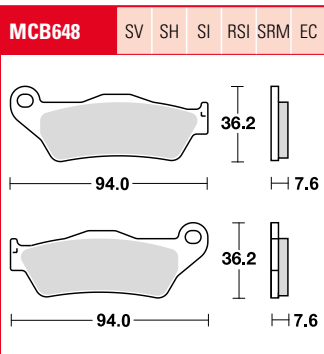
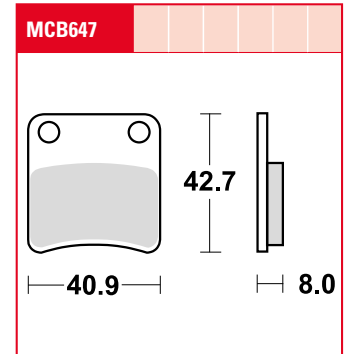
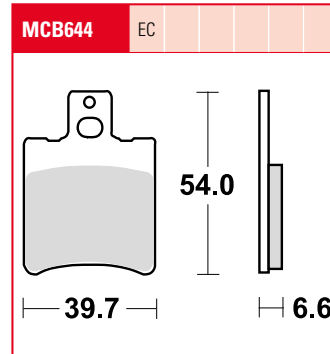
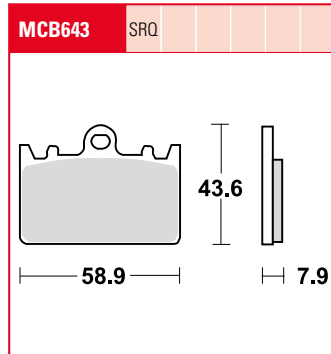
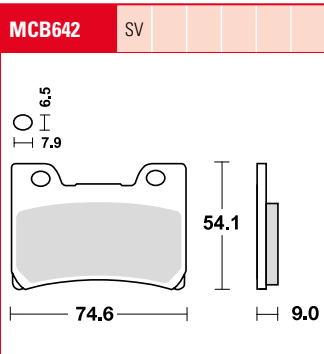
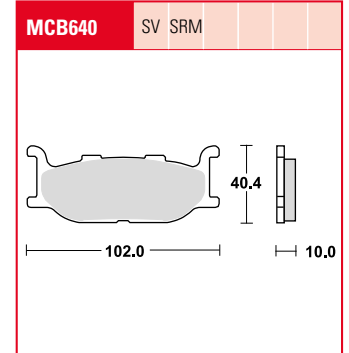
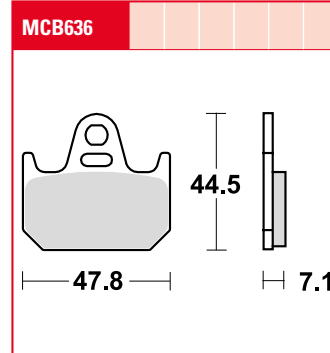
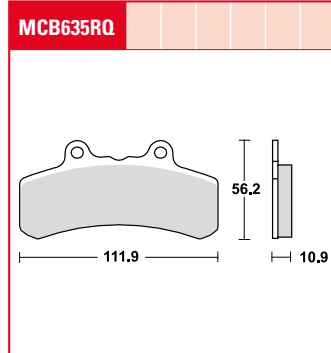
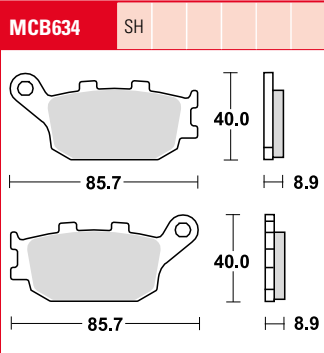
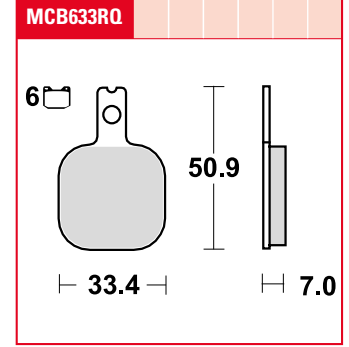
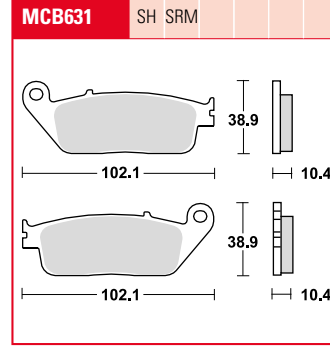
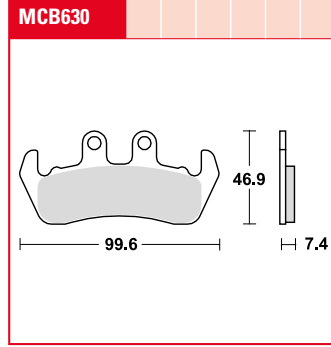
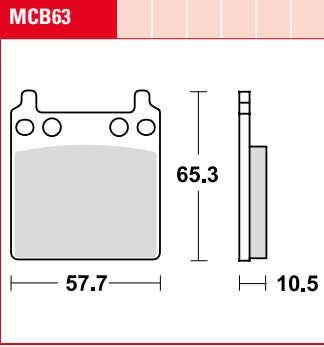

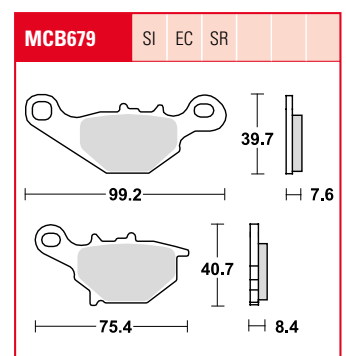
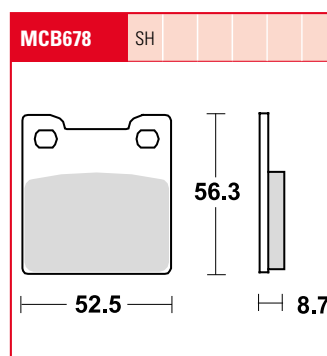
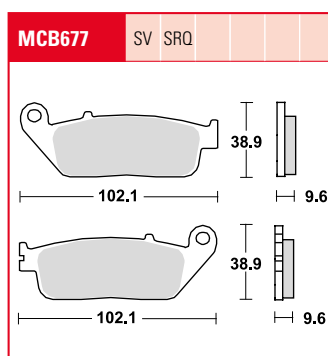
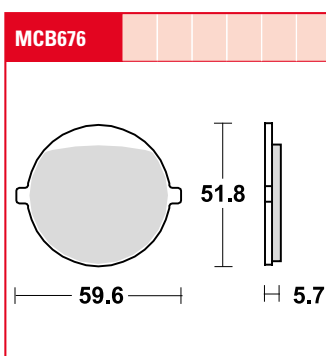
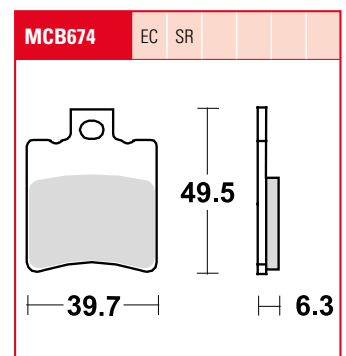
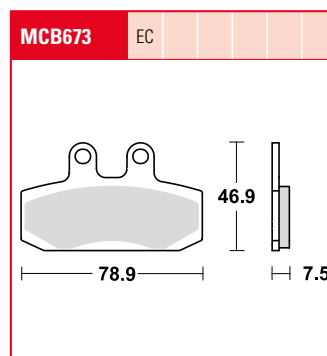
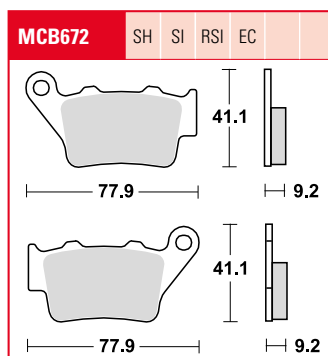
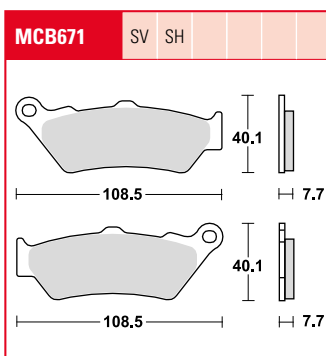
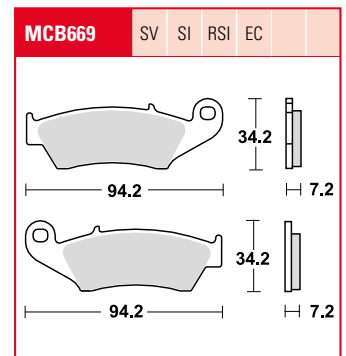
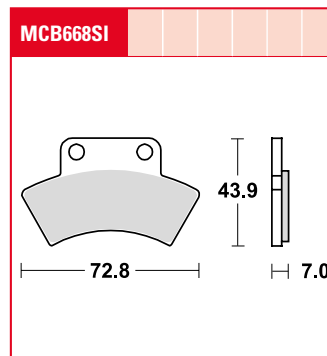
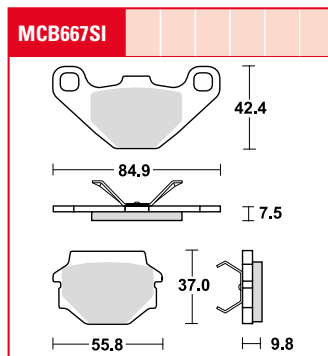
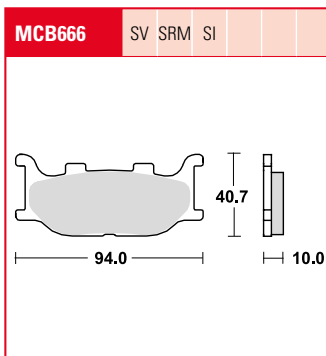
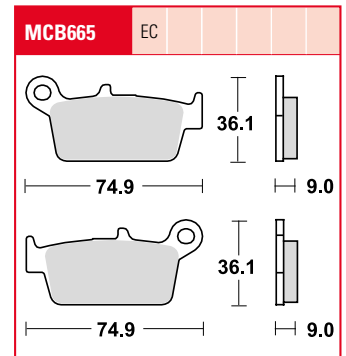
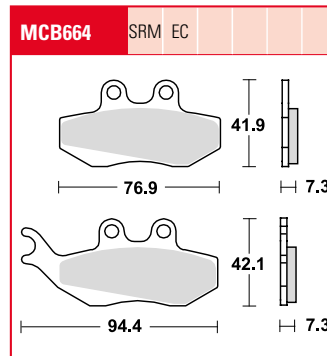
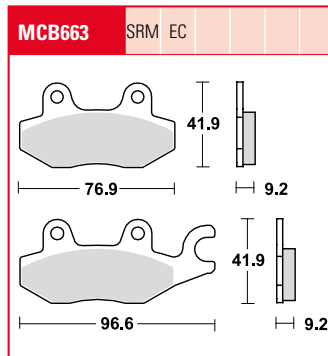
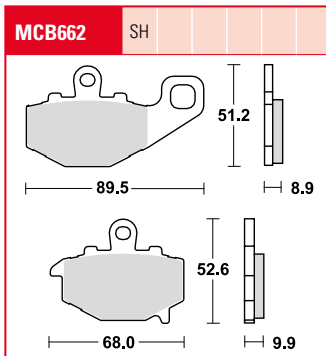
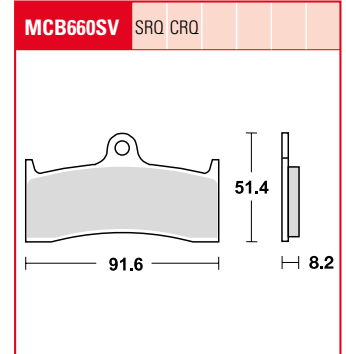
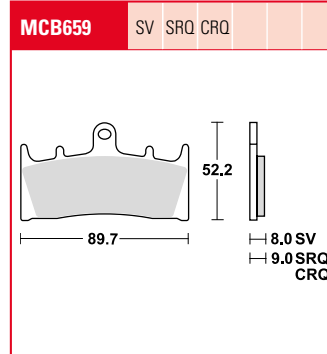
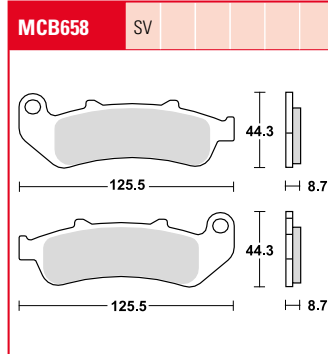
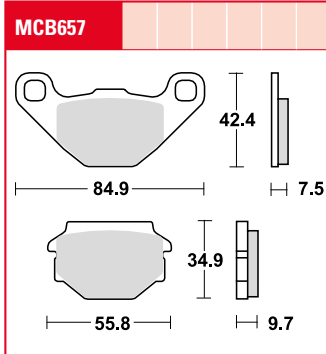

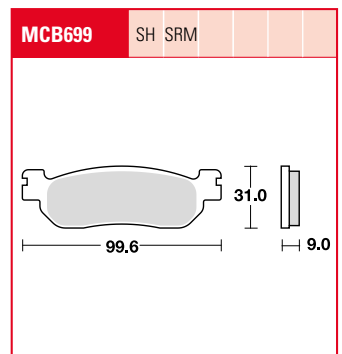
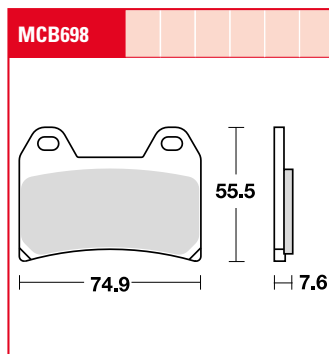
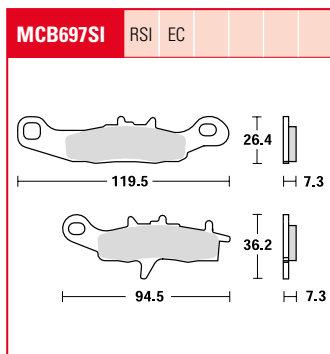
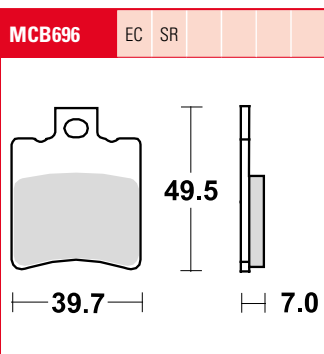
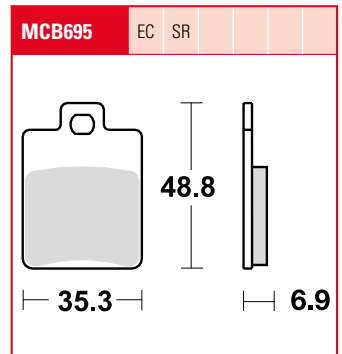
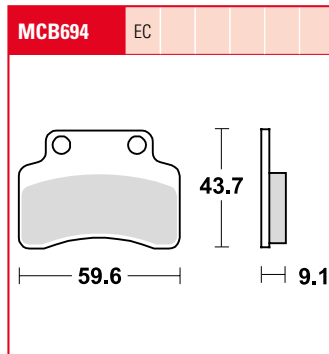
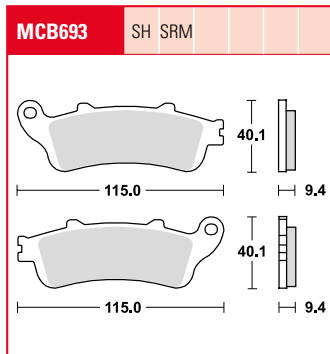
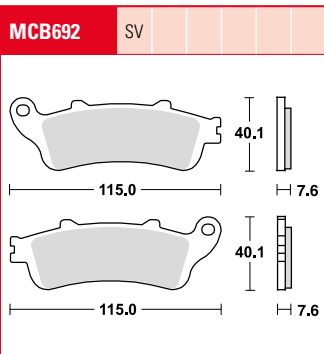
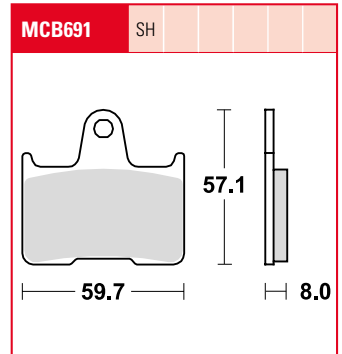
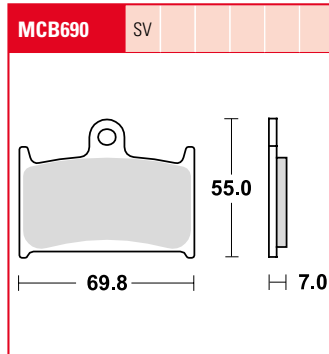
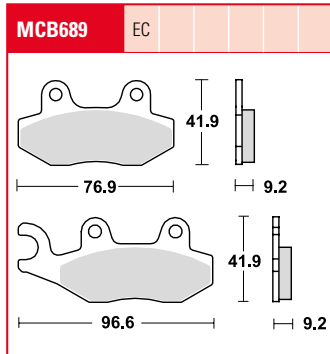
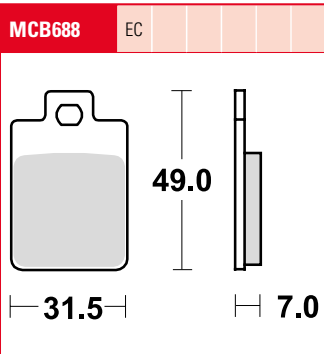
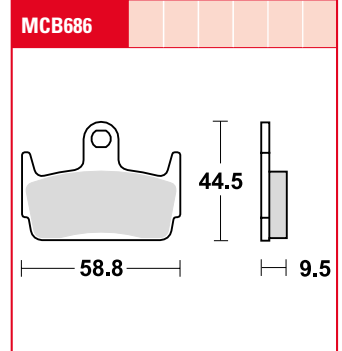
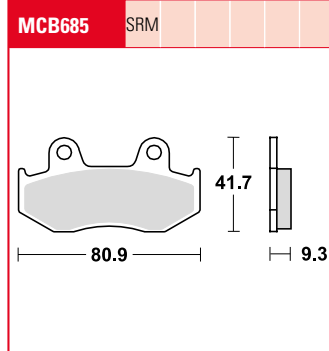
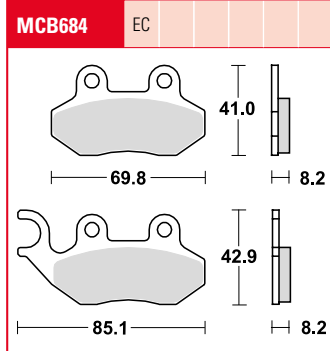
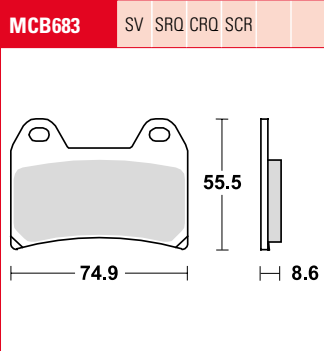
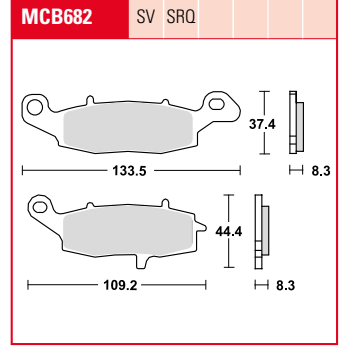
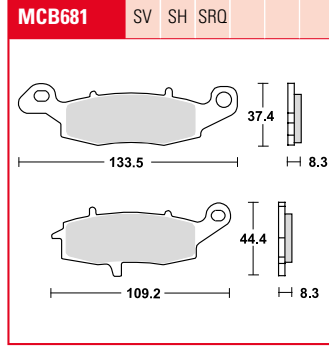
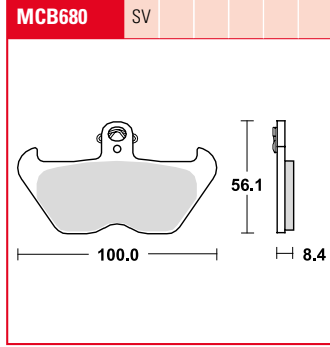
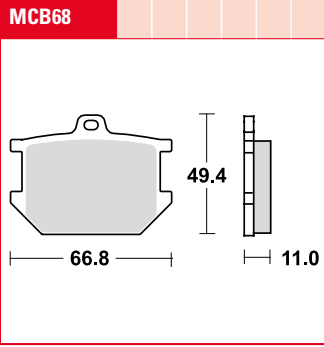

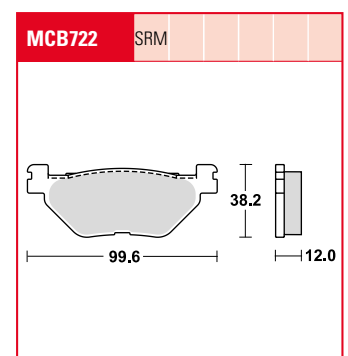
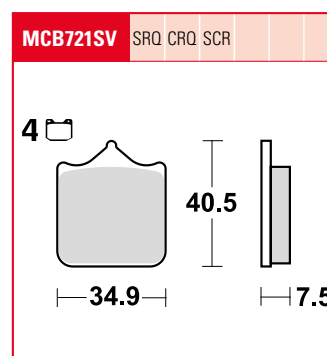
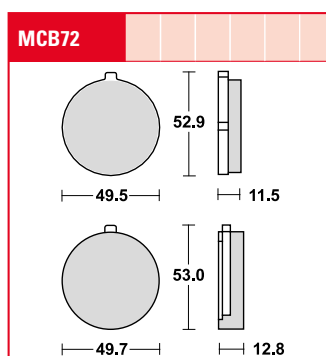
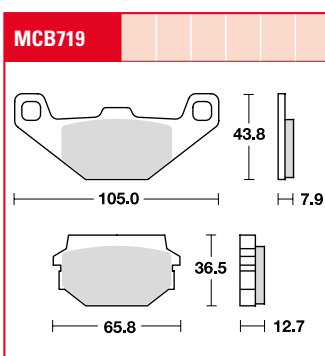
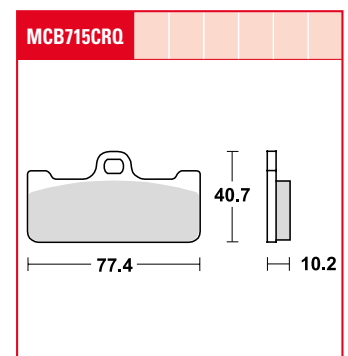
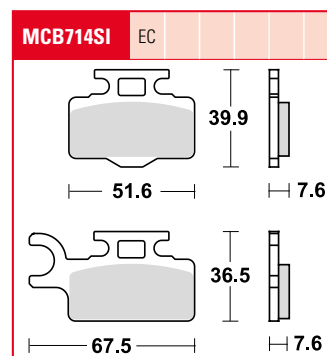
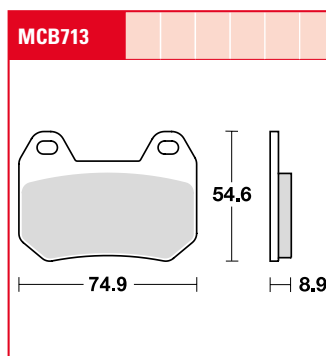
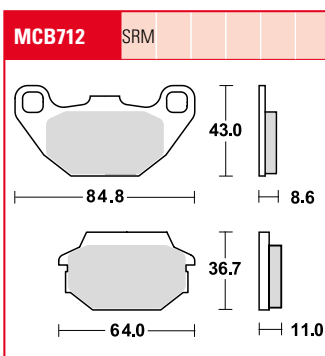
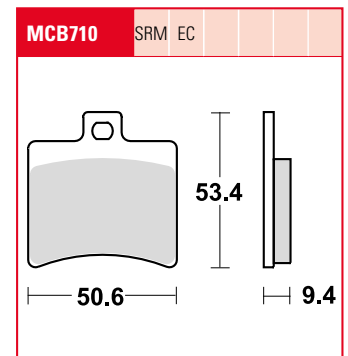
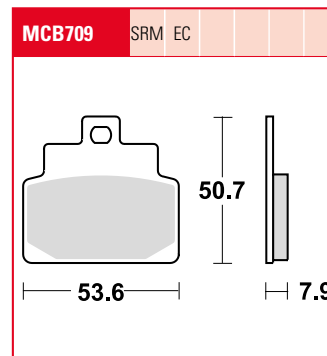
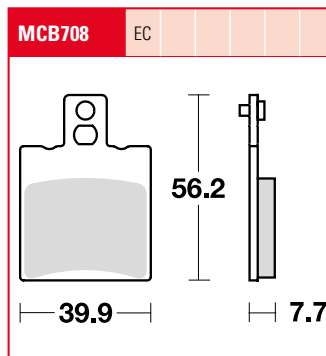
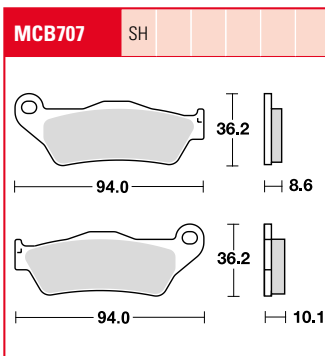
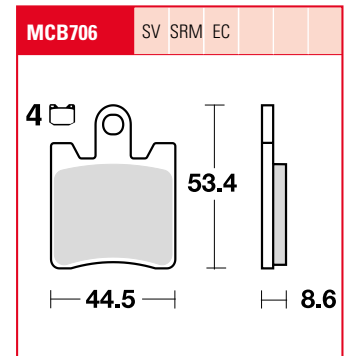
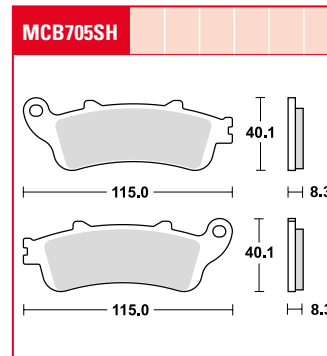
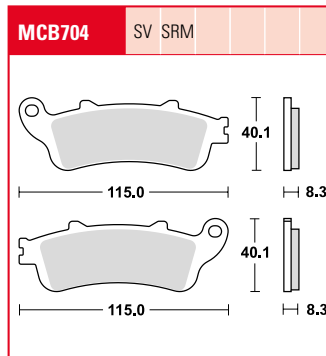
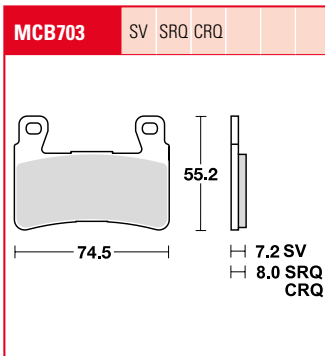
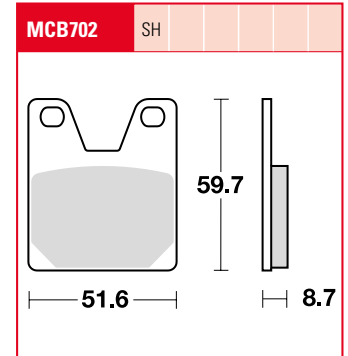
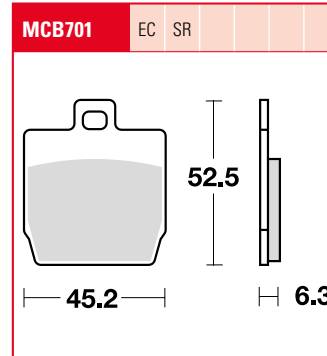
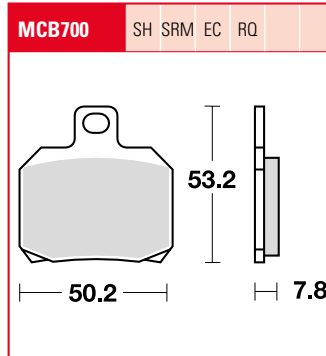
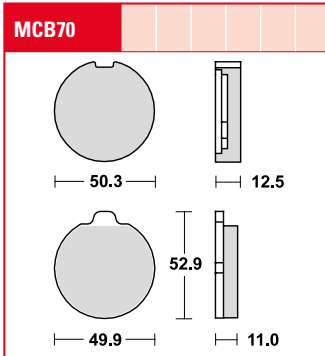

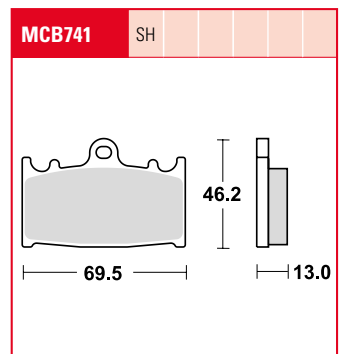
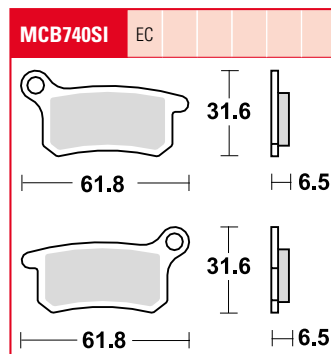
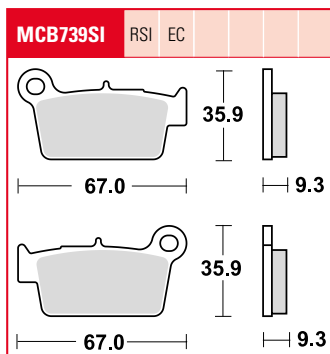
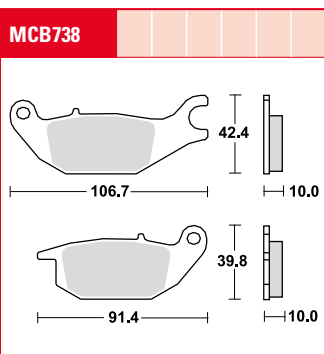
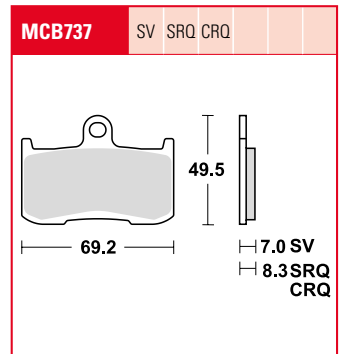
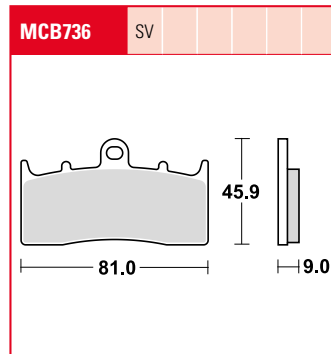
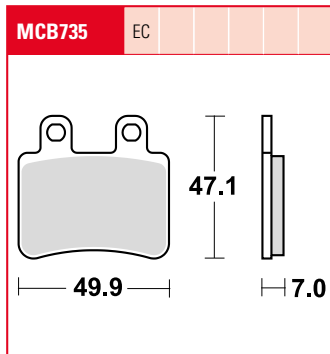
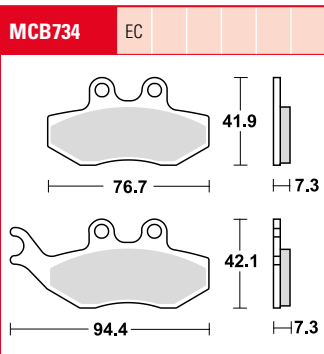
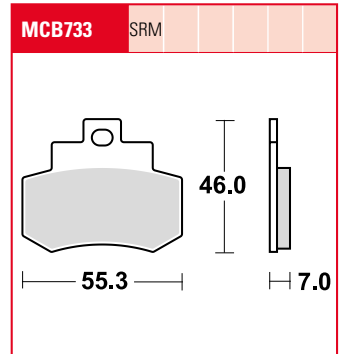
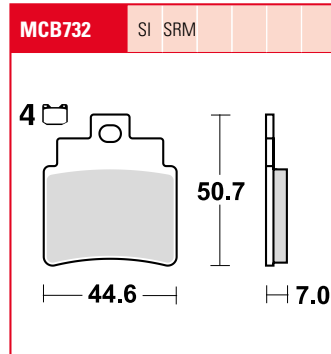
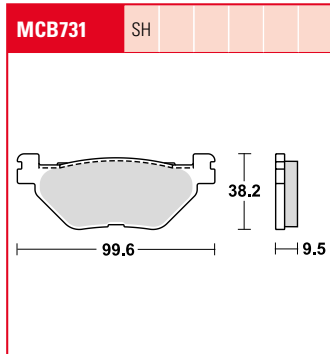
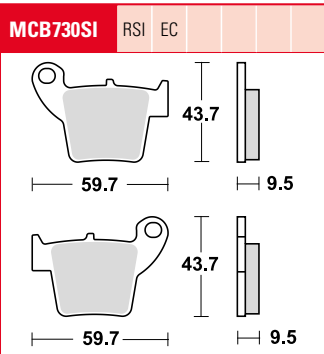
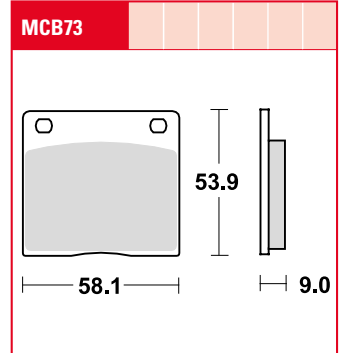
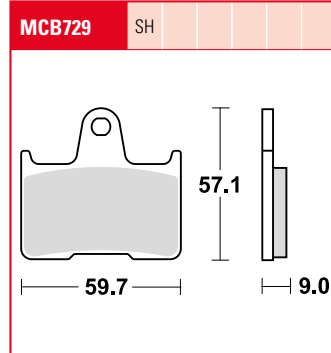
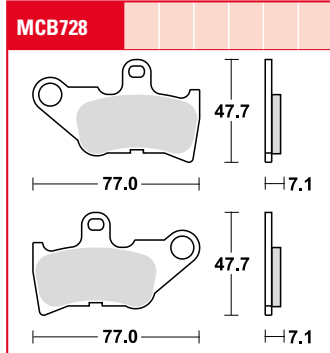
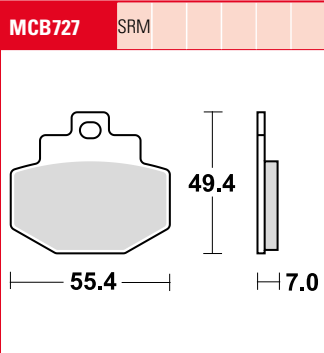
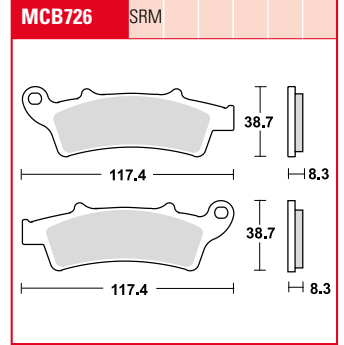
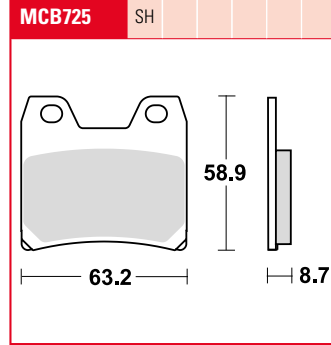
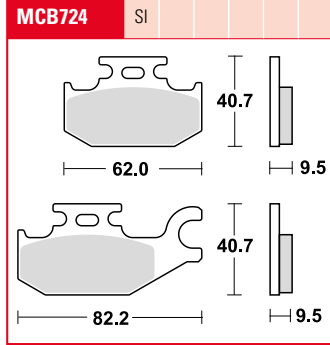
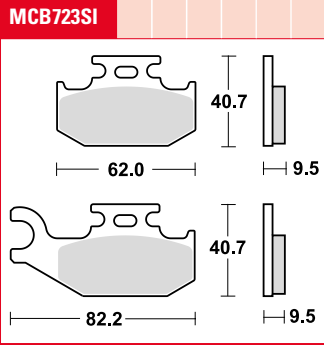

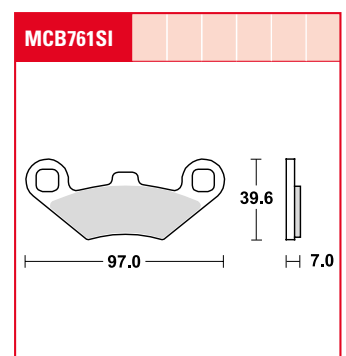
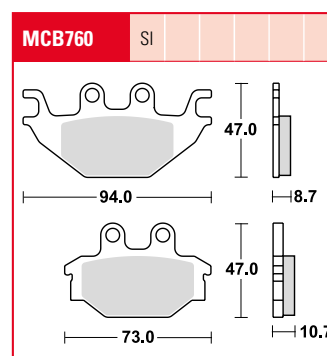
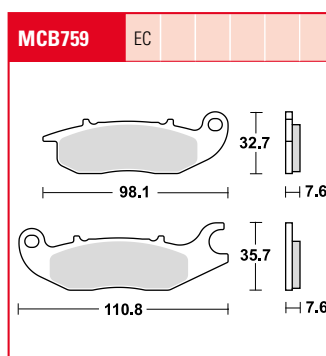
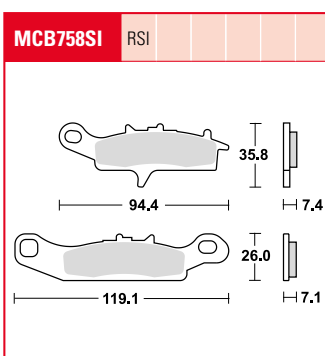
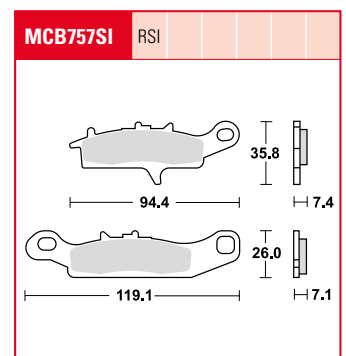
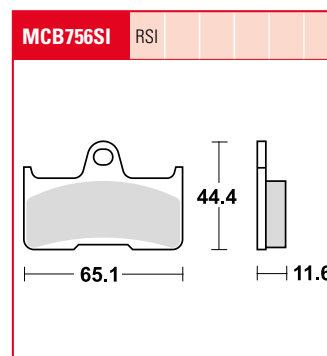
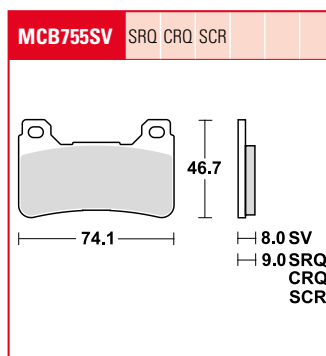
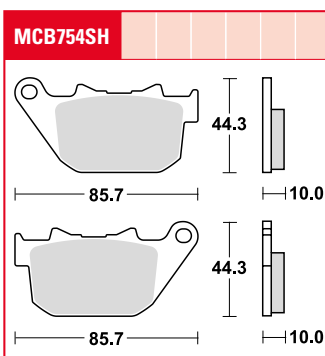
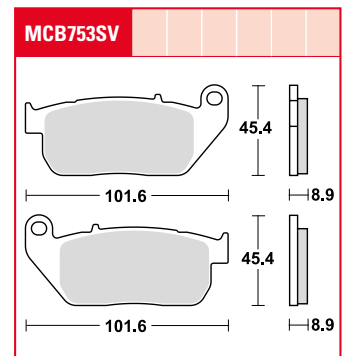
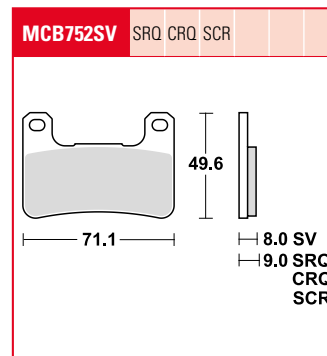
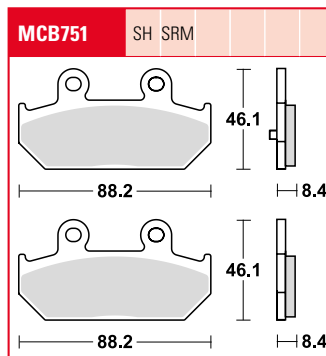
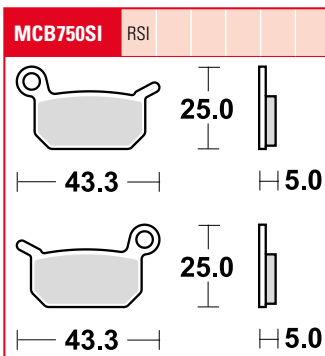
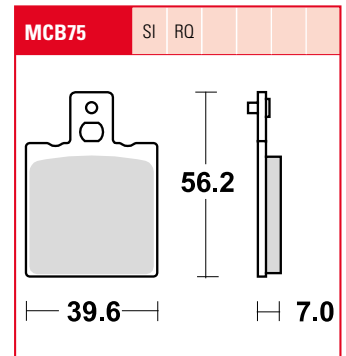
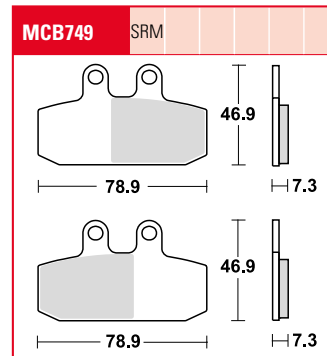
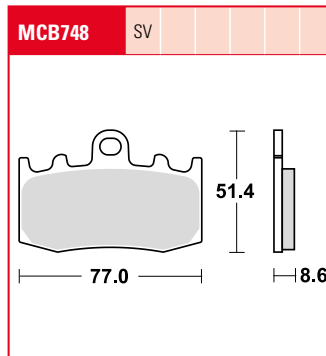
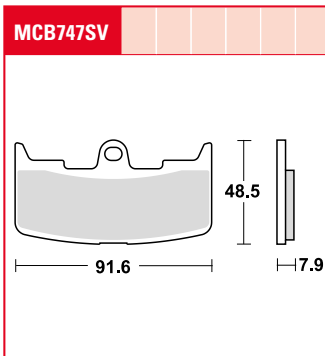
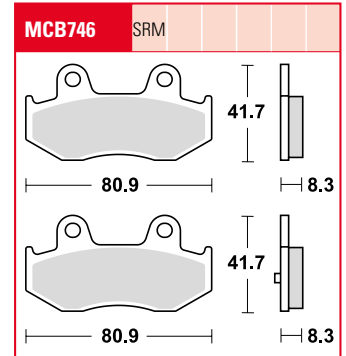
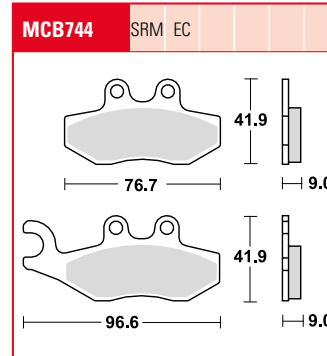
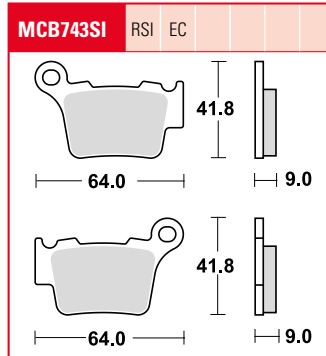
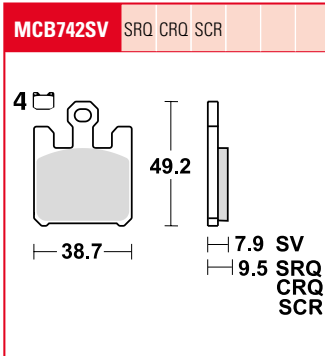



MCB762SI

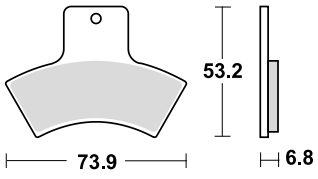

MCB763SI

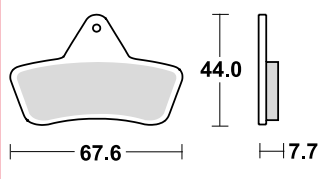

MCB764SH SRM

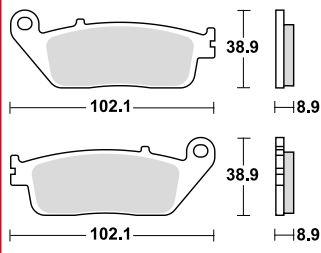

MCB765

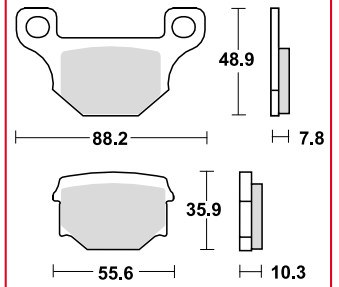

MCB766

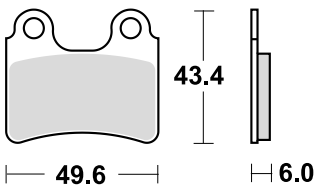

MCB767

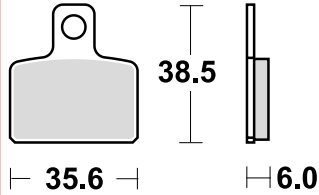

MCB768 SRM

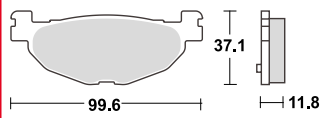

MCB769SI

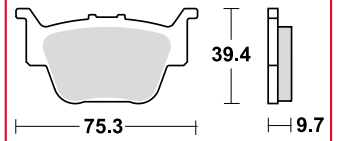

MCB770

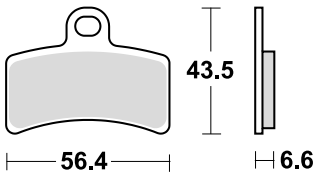

MCB771 SRM

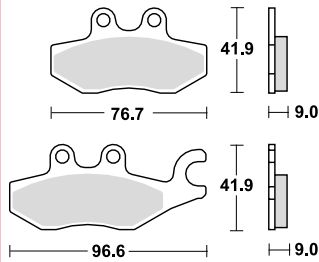

MCB772SI RSI EC

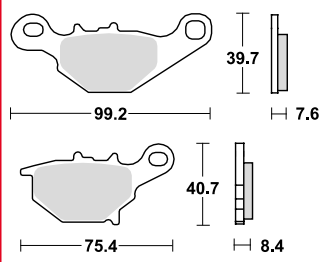

MCB773SI

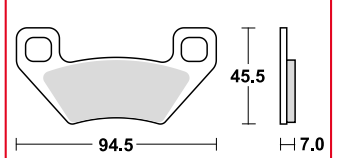

MCB774

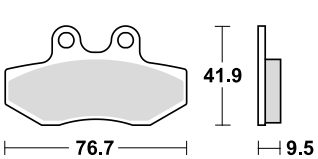

MCB775

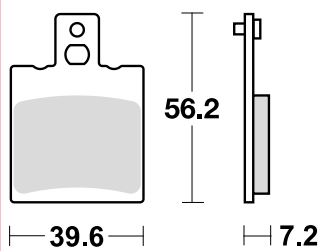

MCB776 SV SH SRM

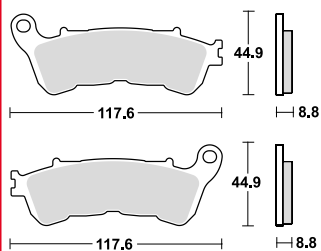

MCB777SV

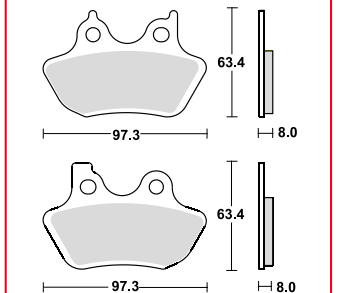

MCB778SH

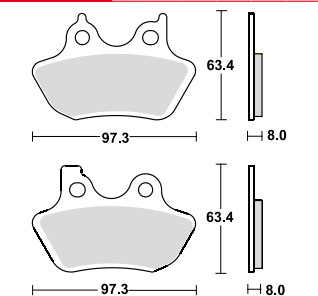

MCB779

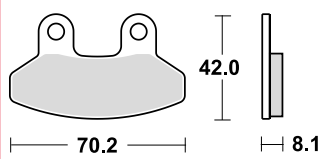

MCB780 SV

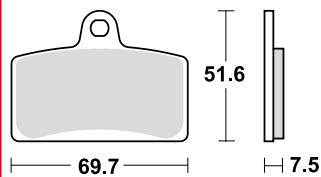

MCB781SV SH

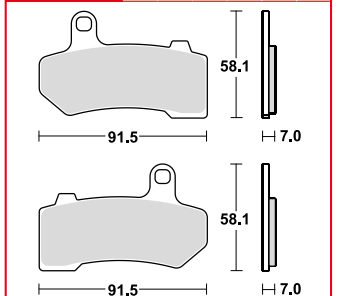

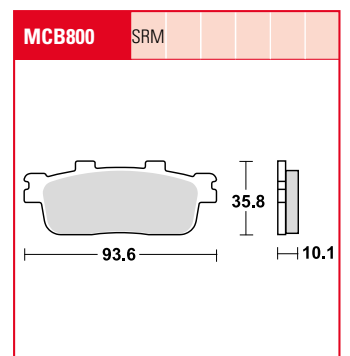
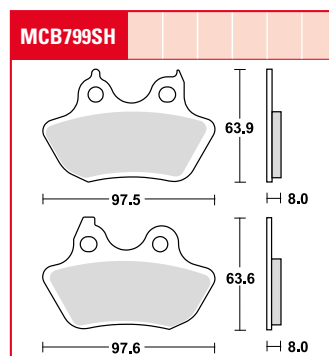
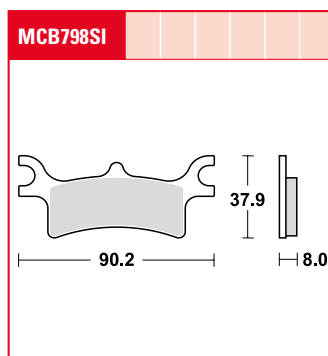
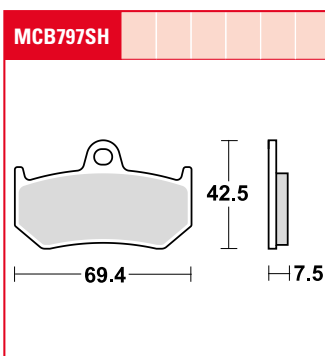
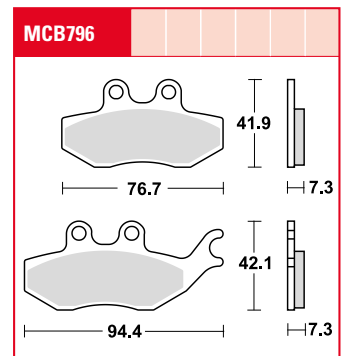
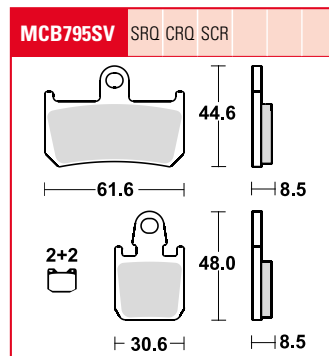
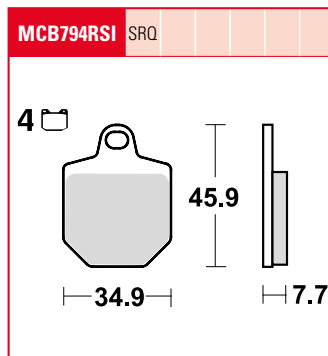
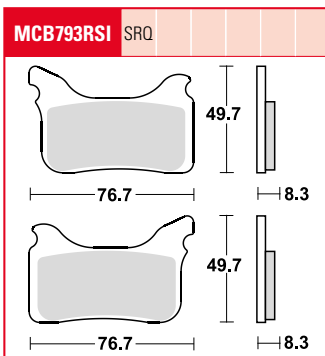
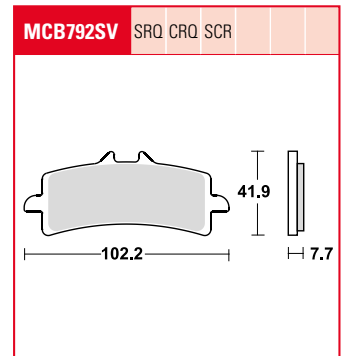
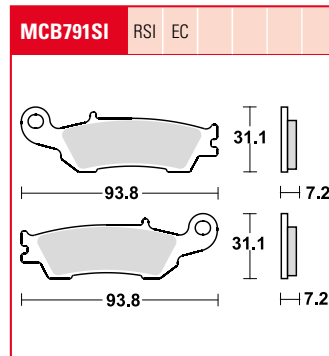
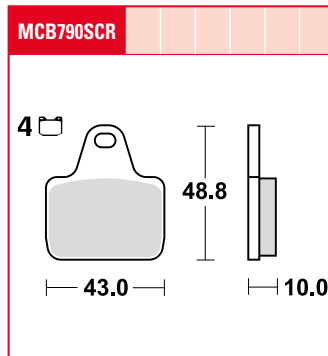
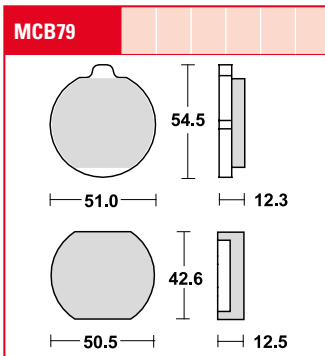
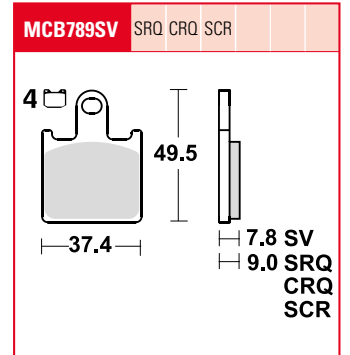
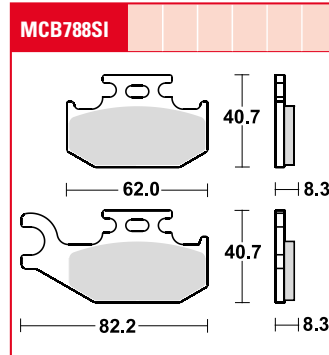
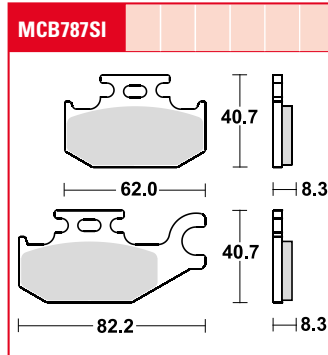
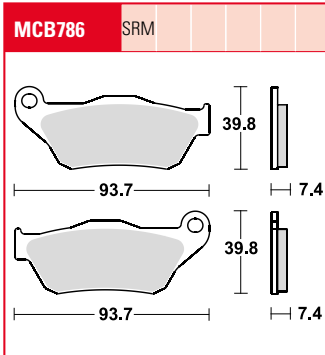
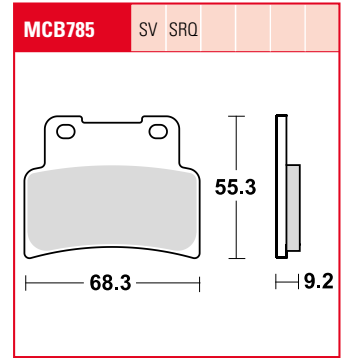
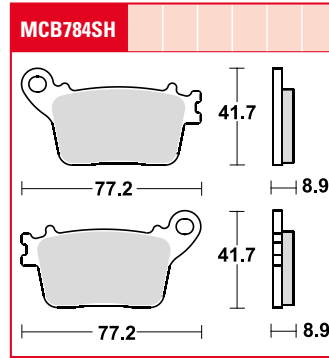
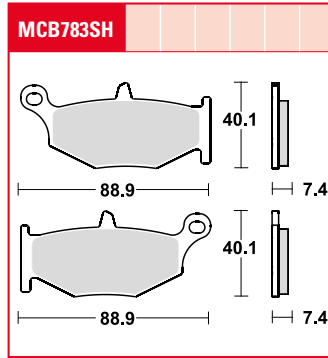
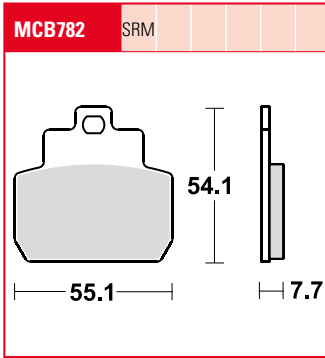



MCB801SI

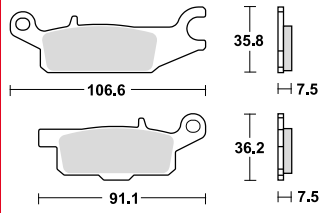

MCB802SI

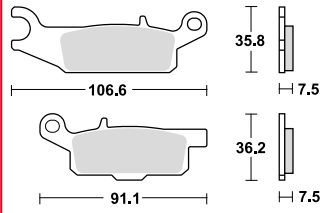

MCB803SI

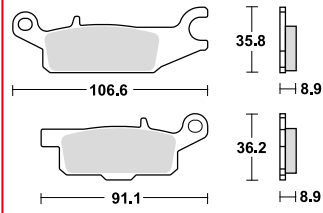

MCB804SI

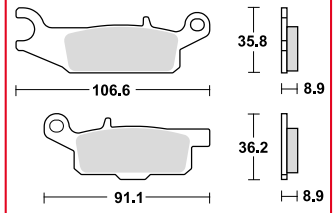

MCB805SI

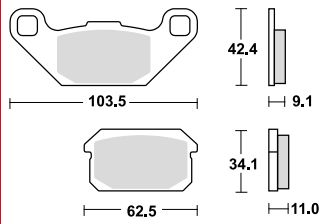

MCB806 SRM

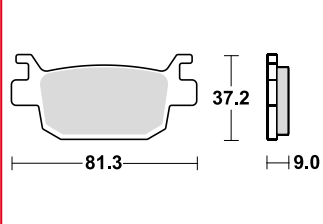

MCB807

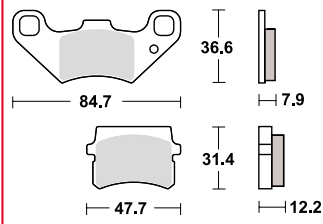

MCB810SV

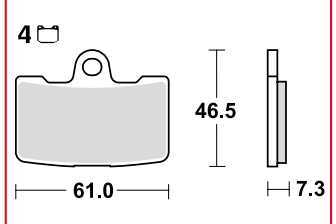

MCB811SH

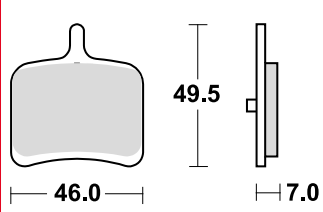

MCB812

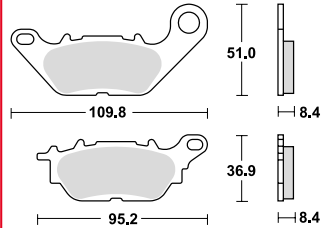

MCB813SV

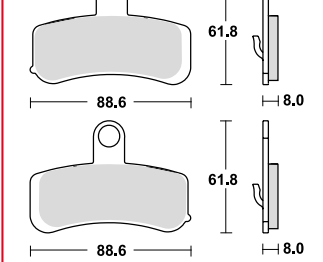

MCB814SH

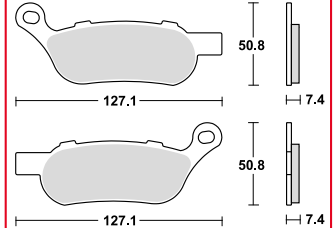

MCB815SCR

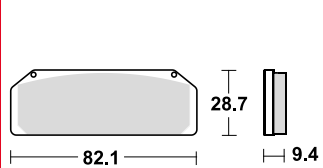

MCB816SV SRQ CRQ

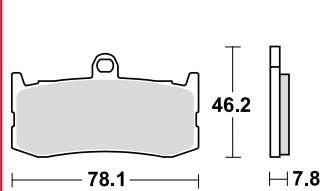

MCB817SH

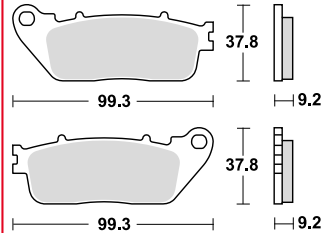

MCB818

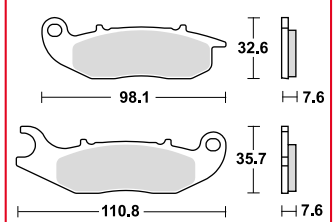

MCB819SV

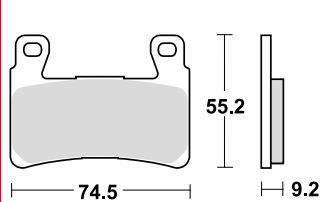

MCB820

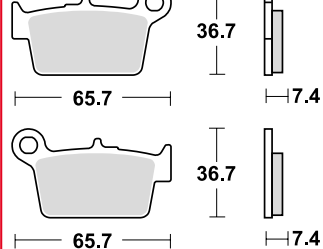

MCB821 SRM EC

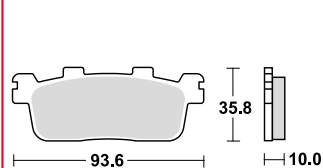

MCB822 SV

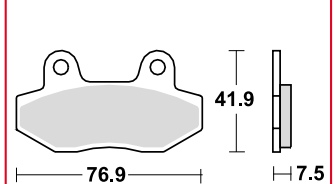



MCB823SI

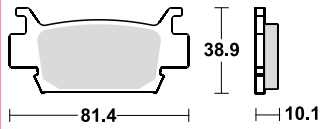

MCB824SI

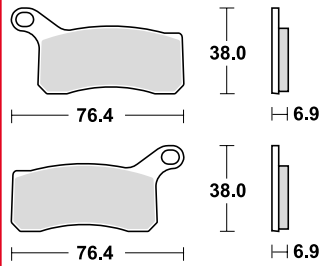

MCB825SI

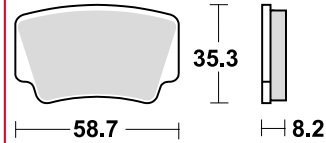

MCB827 SRM

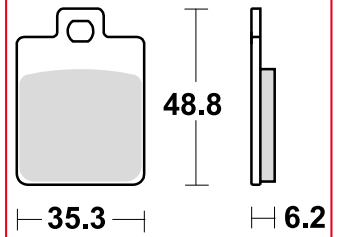

MCB828SV

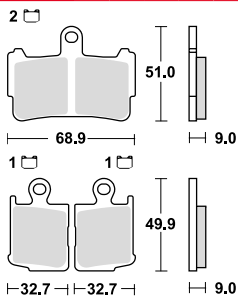

MCB829SV SRQ CRQ SCR

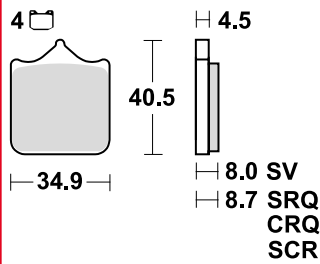

MCB830 SRM

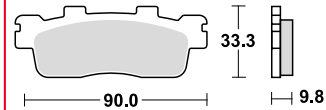

MCB831SI EC

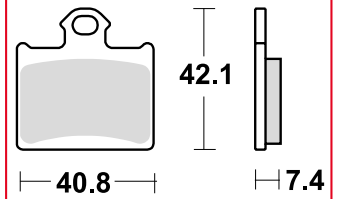

MCB832P

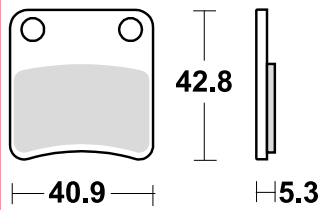

MCB833

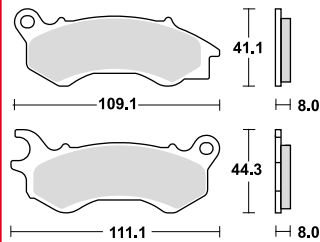

MCB834

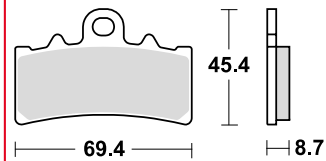

MCB835

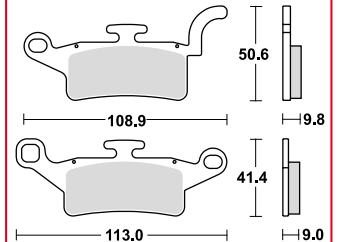

MCB836SI

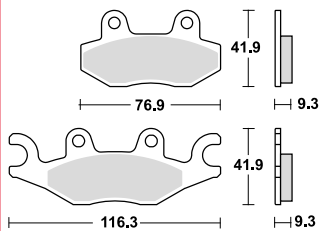

MCB837SRM

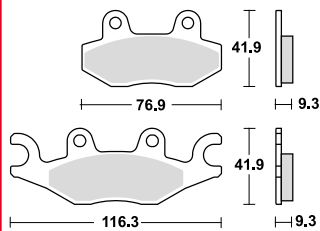

MCB838

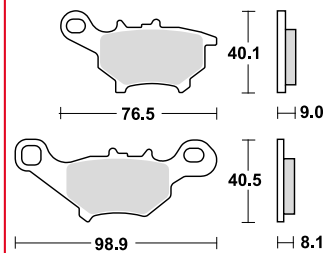

MCB839

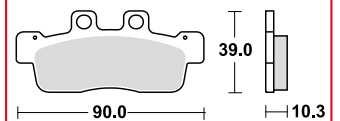

MCB840SH

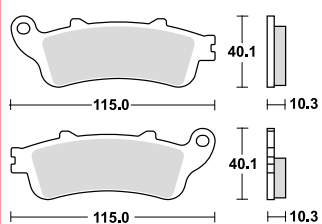

MCB841 SH

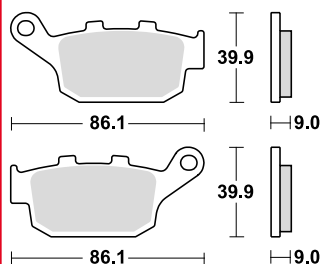

MCB842SI

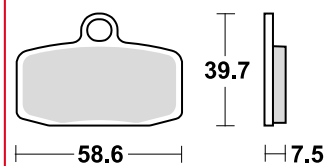

MCB843 SH

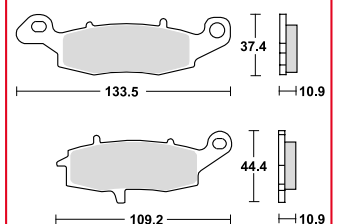

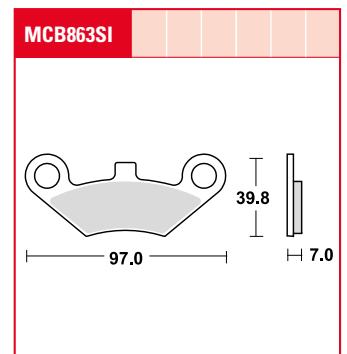
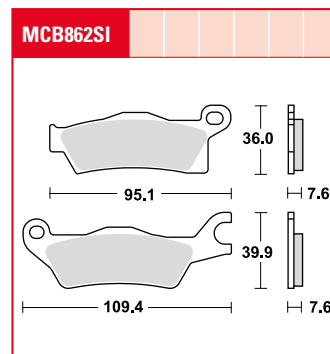
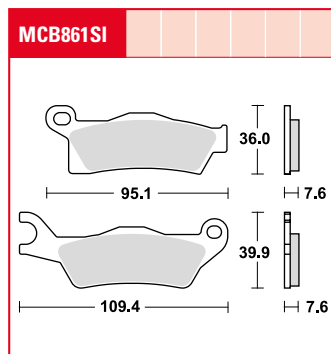
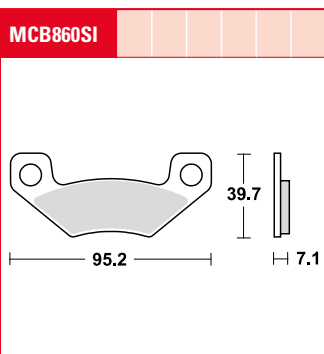
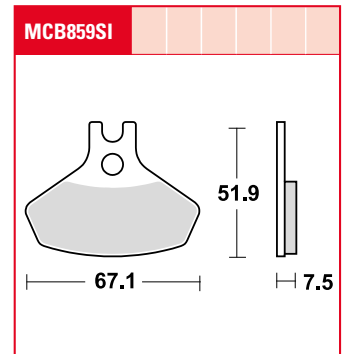
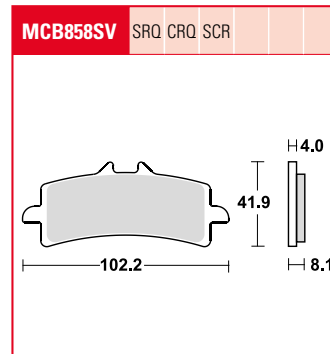
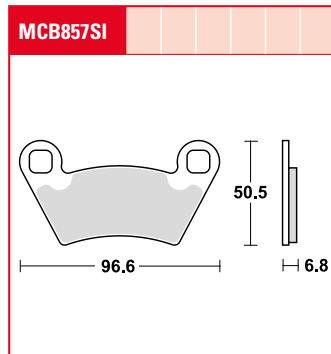
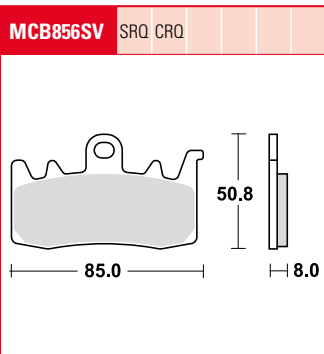
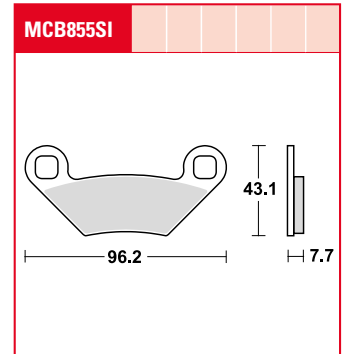
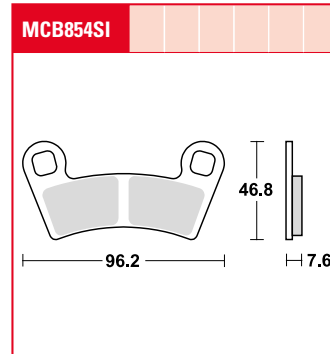
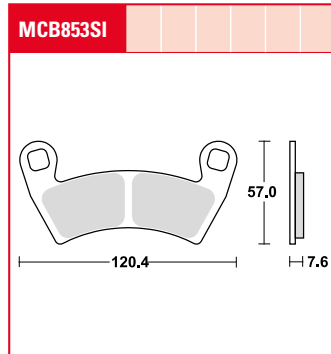
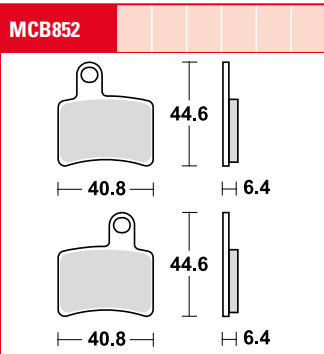
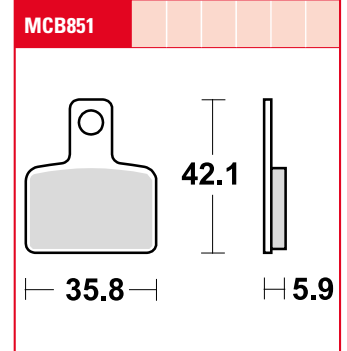
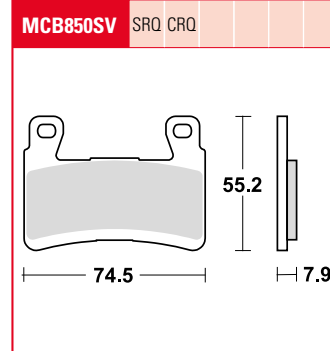
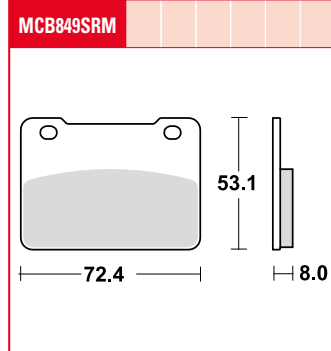
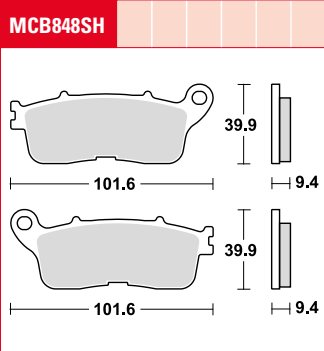
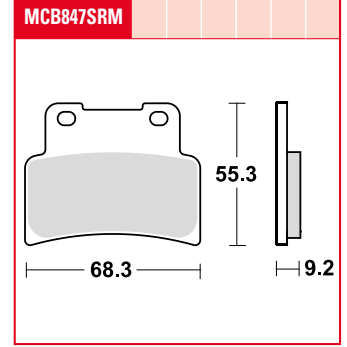
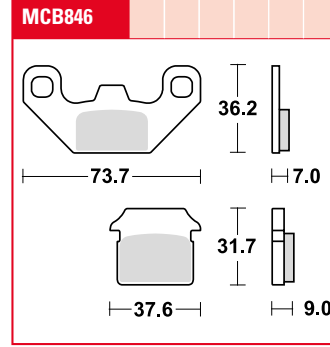
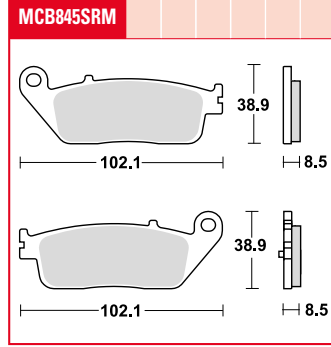
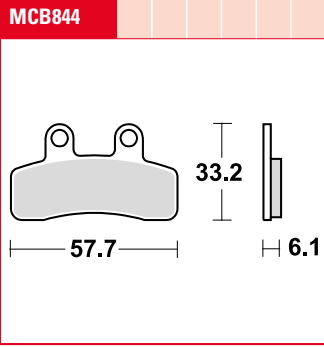



MCB864SH

2 pcs. 4 pcs. 4 pcs.

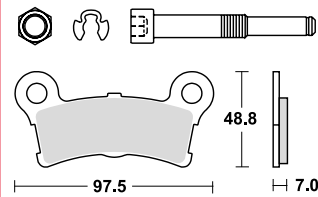

MCB865SV

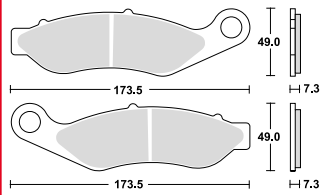

MCB866SH

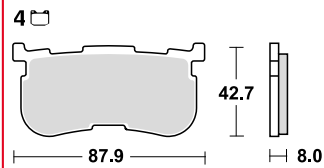

MCB867

SI

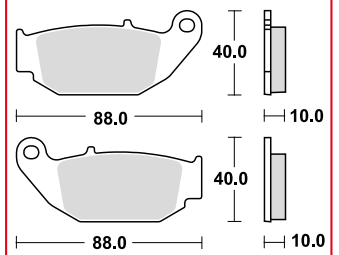

MCB868SI

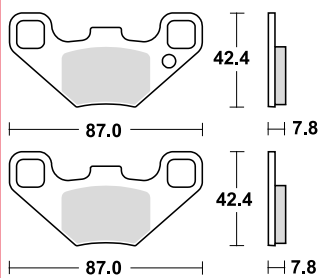

MCB869SI

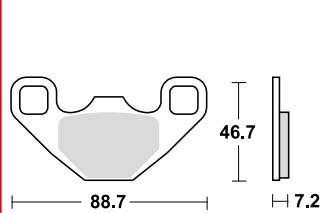

MCB870SH

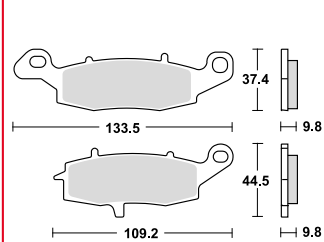

MCB871

SV SH

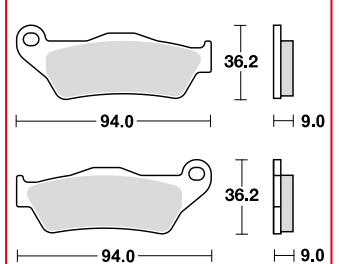

MCB872

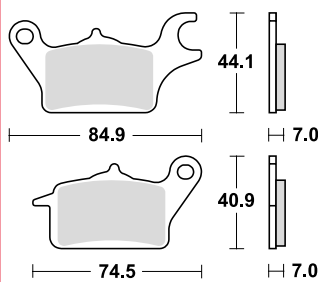

MCB873SRM

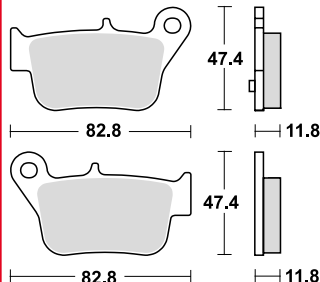

MCB874SRM

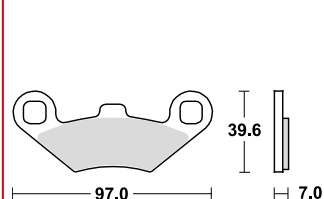

MCB875P

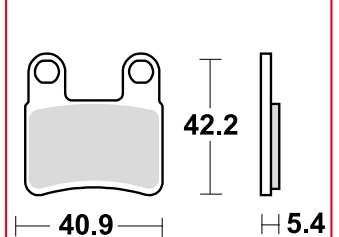

MCB876SV

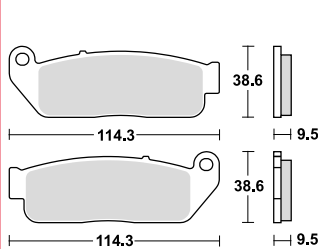

MCB877SH

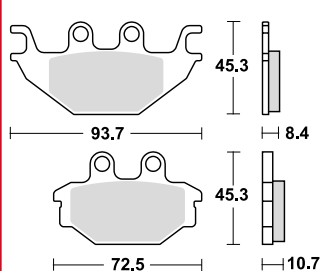

MCB91

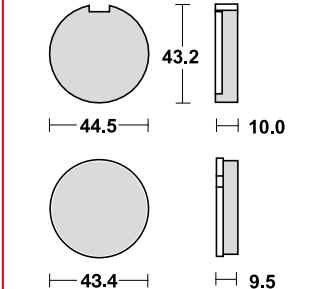

MCB95

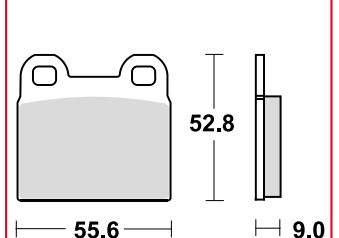

MCB97

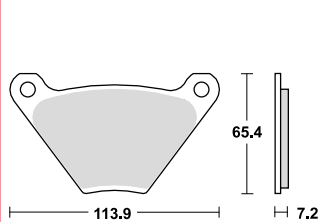

MCB99

CRQ

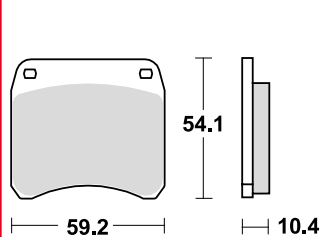



MCS 800 Ø 110 x 25 mm



MCS 802 Ø 160 x 30 mm



MCS 803 Ø 140 x 25 mm



MCS 804 Ø 110 x 25 mm



MCS 805 Ø 130 x 30 mm

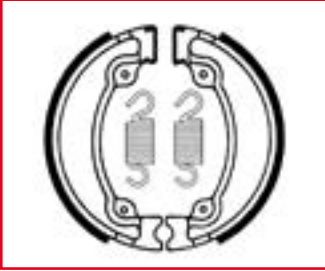

MCS 806 Ø 160 x 40 mm



MCS 807 Ø 140 x 40 mm



MCS 808 Ø 180 x 40 mm



MCS 809 Ø 180 x 30 mm



MCS 810 Ø 160 x 25 mm



MCS 811 Ø 140 x 30 mm



MCS 812 Ø 110 x 30 mm



MCS 813 Ø 095 x 20 mm

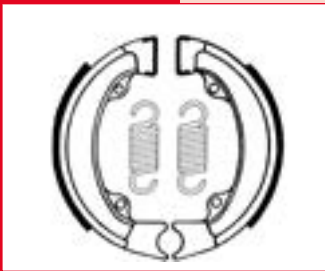

MCS 815 Ø 130 x 25 mm



MCS 817 Ø 130 x 30 mm



MCS 818 Ø 115 x 15 mm



MCS 819 Ø 130 x 25 mm



MCS 820 Ø 130 x 25 mm



MCS 821 Ø 140 x 30 mm



MCS 822 Ø 180 x 35 mm





MCS 823 Ø 130 x 28 mm 	MCS 825 Ø 095 x 20 mm 	MCS 826 Ø 130 x 25 mm 	MCS 827 Ø 080 x 18 mm
MCS 828 Ø 080 x 18 mm 	MCS 831 Ø 130 x 25 mm 	MCS 832 Ø 85 x 20 mm 	MCS 833 Ø 159 x 25 mm
MCS 834 Ø 180 x 34 mm 	MCS 835 Ø 130 x 25 mm 	MCS 836 Ø 130 x 25 mm 	MCS 837 Ø 160 x 20 mm
MCS 838 Ø 80 x 20 mm 	MCS 839 Ø 140 x 28 mm 	MCS 840 Ø 90 x 20 mm 	MCS 841 Ø 165 x 32 mm
MCS 842 Ø 165 x 28 mm 	MCS 843 Ø 130 x 28 mm 	MCS 844 Ø 160 x 25 mm 	MCS 851 Ø 200 x 35 mm



MCS 852 Ø 180 x 40 mm



MCS 853 Ø 160 x 30 mm



MCS 854 Ø 110 x 30 mm



MCS 855 Ø 130 x 28 mm



MCS 857 Ø 090 x 20 mm



MCS 861 Ø 120 x 35 mm

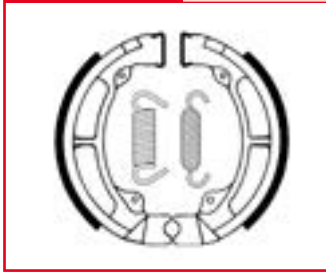

MCS 890 Ø 160 x 30 mm



MCS 891 Ø 150 x 30 mm



MCS 892 Ø 180 x 35 mm

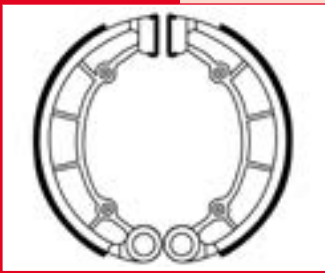

MCS 901 Ø 110 x 25 mm



MCS 902 Ø 150 x 28 mm



MCS 904 Ø 180 x 28 mm



MCS 905 Ø 180 x 40 mm

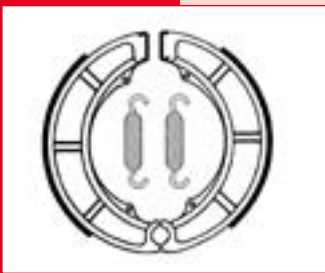

MCS 907 Ø 160 x 30 mm

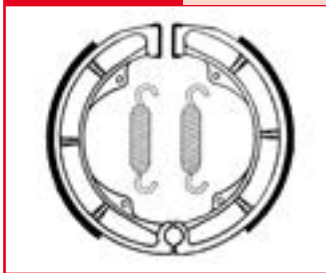

MCS 915 Ø 120 x 22 mm



MCS 919 Ø 160 x 30 mm



MCS 920 Ø 090 x 20 mm



MCS 921 Ø 120 x 25 mm



MCS 940 Ø 200 x 30 mm



MCS 941 Ø 200 x 25 mm





MCS 943 Ø 200 x 23 mm 	MCS 944 Ø 200 x 30 mm 	MCS 945 Ø 200 x 27 mm 	MCS 950 Ø 180 x 40 mm
MCS 951 Ø 110 x 25 mm 	MCS 952 Ø 160 x 25 mm 	MCS 953 Ø 130 x 28 mm 	MCS 954 Ø 180 x 30 mm
MCS 955 Ø 150 x 25 mm 	MCS 956 Ø 110 x 25 mm 	MCS 957 Ø 200 x 40 mm 	MCS 958 Ø 160 x 30 mm
MCS 959 Ø 180 x 36 mm 	MCS 960 Ø 080 x 17 mm 	MCS 961 Ø 095 x 20 mm 	MCS 962 Ø 110 x 25 mm
MCS 963 Ø 095 x 20 mm 	MCS 964 Ø 130 x 22 mm 	MCS 967 Ø 200 x 35 mm 	MCS 968 Ø 130 x 28 mm



MCS 969 Ø 130 x 28 mm



MCS 980 Ø 150 x 24 mm



MCS 981 Ø 125 x 17 mm



MCS 982 Ø 170 x 26 mm



MCS 983 Ø 170 x 26 mm



MCS 984 Ø 110 x 25 mm



MCS 985 Ø 105 x 20 mm



MCS 986 Ø 110 x 23 mm



MCS 987 Ø 110 x 25 mm



MCS 989 Ø 110 x 20 mm



MCS 990 Ø 110 x 23 mm



MCS 991 Ø 100 x 20 mm



MCS 993 Ø 100 x 25 mm



MCS 994 Ø 140 x 25 mm



MCS 995 Ø 160 x 30 mm



MCS 996 Ø 140 x 25 mm



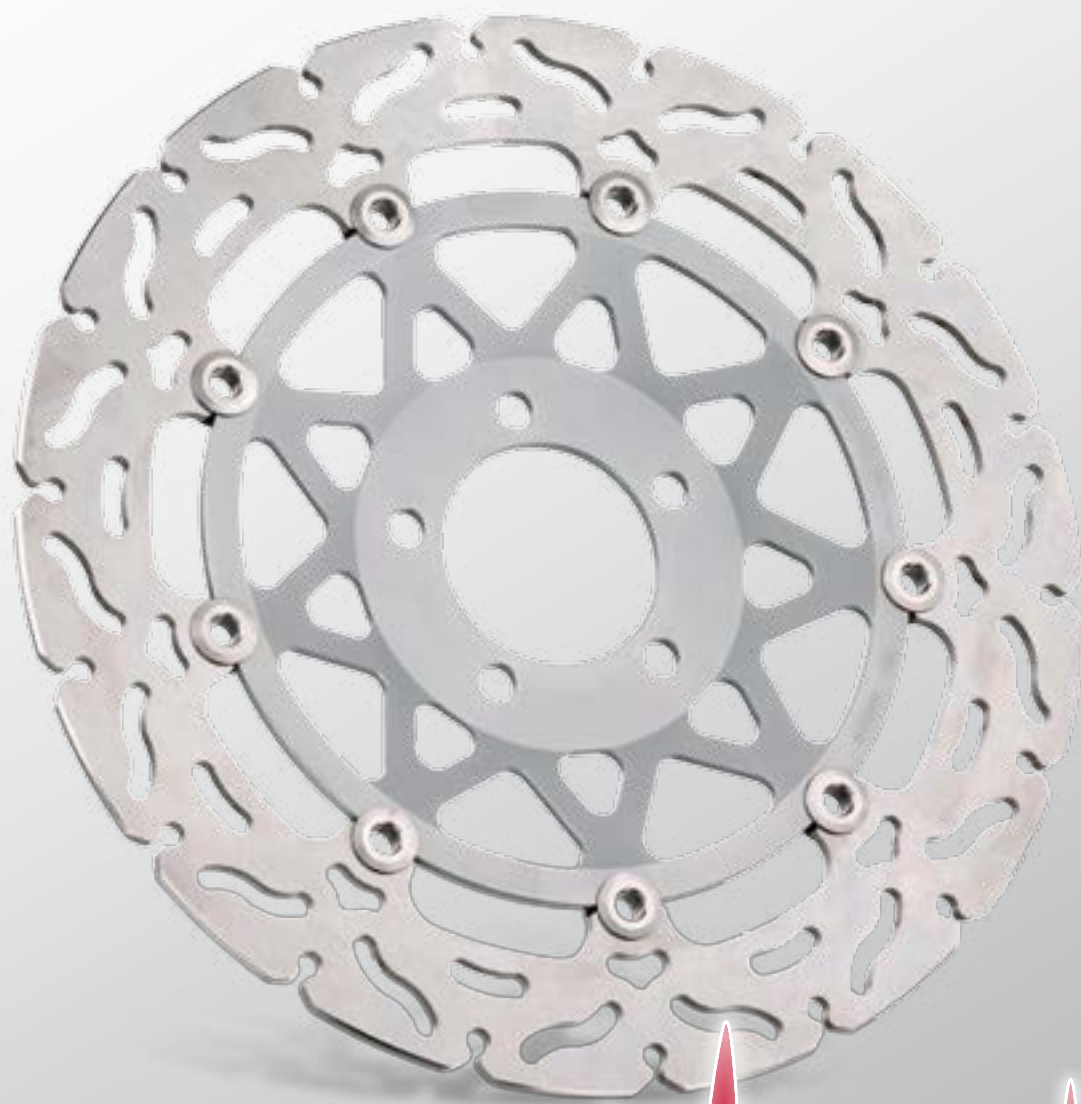

BREMSSCHEIBEN

DISQUES DE FREINS

BRAKE DISCS



BREMSSCHEIBEN

BRAKE DISCS *DISQUES DE FREINS*

Austausch-Bremsscheiben mit ABE aus hochwertigem Stahl

- » extrem formbeständiger Stahl nach 35 HRC Standard, gehärtet und thermisch nachbehandelt
- » spezieller Oberflächenschliff wirkt Vibrationen entgegen und verbessert die Anpassung der Beläge
- » bei den schwimmenden Bremsscheiben ist der gefräste Innenring aus Aluminium und edel titanfarben eloxiert
- » Korrosionsschutz durch hohen Edelstahlanteil
- » verwendbar mit allen TRW-Belagmischungen
- » **Bremsscheiben werden einzeln geliefert**

Replacement brake discs made from high-grade steel, TÜV approved

- » *high-strength steel alloy in accordance with standard 35 HRC, hardened and tempered*
- » *special ground surface finish assists in reducing vibration and improves pad performance*
- » *the ground inner ring of floating brake discs is made of aluminium and exclusively anodized in a titanium colour finish*
- » *corrosion protection due to high ratio of stainless steel*
- » *can be used with all types of TRW pads*
- » **brake discs are supplied individually**

Disque de freins de rechange fabriqué dans un inox de très haute qualité

- » *acier indéformable, selon le HRC 35 standard, durci et soumis à un post-traitement thermique*
- » *parfait état de surface pour éviter les vibrations et améliorer la performance des plaquettes*
- » *la frète intérieure de ce disque flottant est réalisé en aluminium avec une anodisation particulière en couleur gris titane*
- » *protection contre la corrosion garantie par une teneur élevée en acier inoxydable*
- » *compatibles avec les autres qualités de plaquettes TRW*
- » **les disques de frein sont fournis à la pièce**

RAC-BREMSSSCHEIBEN

RAC BRAKE DISCS *DISQUES DE FREIN RAC*

Superleicht und extrem hitzebeständig!

Superlight and extremely heat-resistant!

Extremement légers et très résistants aux températures élevées!



Cooler Design, Hightech-Produktion, mit ABE, zum attraktiven Preis:

- » Hochleistungslaserschneider ermöglichen filigrane Formgebung
- » selbst bei hoher Beanspruchung geringer Verschleiß
- » konstante Aufrauung verhindert die Verglasung der Beläge
- » gleichmäßiger Temperaturauf- und -abbau
- » die RAC-Kontur ermöglicht einen stabilen Druckpunkt
- » einsetzbar in allen Rennsportkategorien

Cool design, high technology production, TÜV approved, at an attractive price:

- » outstanding silhouette produced by high-performance laser cutting
- » low wear even under high stress
- » constant roughening prevents glazing of the pads
- » uniform increase and decrease in temperature
- » the RAC contour ensures a stable pressure point
- » can be used in all categories of motor sport

Un super design, une technologie de pointe, TÜV homologué, à un prix très attractif:

- » un dispositif de coupe en laser de haute performance permet d'obtenir des disques façonnés tout en finesse
- » faible usure, même en cas d'importantes sollicitations
- » la rugosité constante empêche que les plaquettes deviennent lisses
- » baisse et une montée régulières de la température
- » le contour RAC garantit un point de pression stable
- » utilisables dans toutes les catégories de courses sportives



BREMSSCHEIBEN MIT ABE

DISQUES DE FREIN AVEC TÜV HOMOLOGATION

BRAKE DISCS WITH TYPE APPROVAL



ALLROUND STREET

- » runde Außenkontur mit gelochtem Bremsband
- » in starren und schwimmenden Varianten
- » abgestimmtes Design von Vorder- zu Hinterachse
- » *round external contour with perforated brake band*
- » *fixed and floating versions available*
- » *Design aligned for front and rear axle*
- » *contours extérieurs arrondis avec ruban de frein perforé*
- » *variantes fixes et flottantes*
- » *Design pour essieux avant et arrière*



RAC SPORTIV

- » eingekerbte Außenkontur mit geschlitztem Bremsband
- » in starren und schwimmenden Varianten
- » abgestimmtes Design von Vorder- zu Hinterachse
- » *notched external contour with notched brake band*
- » *fixed and floating versions available*
- » *Design aligned for front and rear axle*
- » *contours extérieurs rainurés avec ruban de frein fendu*
- » *variantes fixes et flottantes*
- » *Design pour essieux avant et arrière*

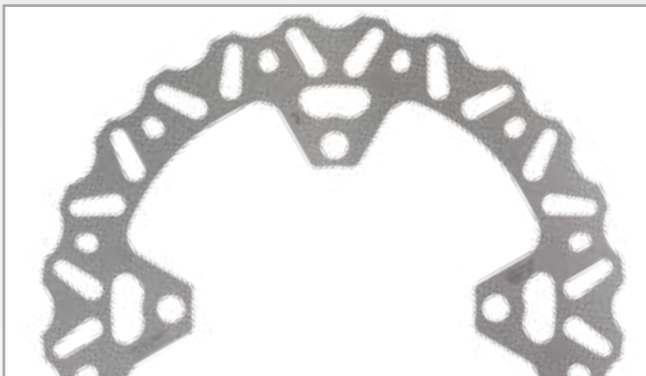

EC OFFROAD

- » gehärtete Stahllegierung für lange Lebensdauer
- » mit allen Offroad-Belagsmischungen kombinierbar
- » ansprechendes Design und hochwertige Verarbeitung
- » perfektes Ansprechverhalten, ausgezeichnete Dosierbarkeit
- » extrem attraktives Preisniveau
- » *hardened alloy steel for a long service life*
- » *can be combined with all offroad lining mixtures*
- » *attractive design and high-quality workmanship*
- » *perfect response and excellent controllability*
- » *extremely attractive pricing*
- » *alliage d'acier trempé pour des durées de vie prolongées*
- » *combinaison possible avec tous les alliages de plaquettes offroad*
- » *design attrayant et traitement de qualité*
- » *capacité de réaction parfaite, dosage exceptionnel*
- » *niveau de prix extrêmement attractif*



FS BMW – FLOATING SYSTEM

- » innovative Konstruktion
- » Optimierung der Bremse
- » hohe Hitzeableitung
- » für extreme Beanspruchung
- » auch für ABS Modelle
- » *innovative design*
- » *optimises the brake*
- » *high heat dissipation*
- » *for extreme demands*
- » *also for ABS models*
- » *construction innovante*
- » *optimisation du système de freinage*
- » *grande capacité d'évacuation de la chaleur*
- » *pour les sollicitations extrêmes*
- » *également disponible pour les modèles équipés de l'ABS*

BREMSSCHEIBEN OHNE ABE

DISQUES DE FREIN SANS TÜV HOMOLOGATION
BRAKE DISCS WITHOUT TYPE APPROVAL



SP RACING

- » Aussenring 5,5 mm Stärke
- » 10 Floater System
- » vollschwimmende Verbindung
- » schwarzer Innenring, gelochtes Bremsband
- » *outer ring 5.5 mm thickness*
- » *10 floater system*
- » *fully floating connection*
- » *black inner ring, perforated brake band*
- » *Épaisseur de la piste : 5,5 mm*
- » *Système de liaison frette-piste à 10 rivets*
- » *Disques flottants*
- » *Frette de couleur noire, et piste de frein perforée*



RAC-SP RACING

- » Aussenring 5,5 mm Stärke
- » 10 Floater System
- » vollschwimmende Verbindung
- » schwarzer Innenring, gekerbtes Bremsband
- » *outer ring 5.5 mm thickness*
- » *10 floater system*
- » *fully floating connection*
- » *black inner ring, notched brake band*
- » *Épaisseur de la piste : 5,5 mm*
- » *Système de liaison frette-piste à 10 rivets*
- » *Disques flottants*
- » *Frette de couleur noire, et piste de frein perforée*



SL RACING

- » nur für Rennsportzwecke
- » Hinterachsen-Scheibe im RAC Design
- » besonders leichte Ausführung
- » geringere Stärke
- » *without TÜV approval, for racing use only*
- » *rear axle disc in RAC design*
- » *particularly lightweight version*
- » *smaller thickness*
- » *sans TÜV, uniquement pour les sports de course*
- » *Disque pour essieu arrière, design RAC*
- » *Modèle particulière léger*
- » *faible épaisseur*



SP-BREMSSCHEIBEN FÜR RENNSPORT

DISQUES DE FREIN SP POUR LA COMPETITION

SP BRAKE DISCS FOR RACING

High Performance!

SP-Bremsscheiben für den Rennsport

- » Gewichtsoptimiert für maximale thermische Belastung
- » Aussenring Stärke von 5,5 mm für Serienzangennutzung
- » Hohe mechanische Stabilität durch 10 Floater System
- » Vollschwimmende, gewichtsoptimierte Floater Verbindungen
- » CNC gefräster Innenring aus Billet Luftfahrt Aluminium
- » einsetzbar in allen Rennsportkategorien
- » schwarz eloxierter Innenring
- » Design wählbar in SP oder RAC-SP
- » SP-Bremsscheiben verfügen über keine Straßenzulassung

High performance!

SP brake discs for racing

- » weight optimised for maximum thermal load
- » outer ring thickness 5.5 mm for use with standard calipers
- » high mechanical impact stability through 10 floater system
- » fully floating, weight optimised floater connections
- » CNC milled inner ring made of billet aerospace aluminium
- » suitable for all racing categories
- » black anodised inner ring
- » choose design: SP or RAC-SP
- » SP brake discs have no approval for road use

Haute performance !

Disques de frein SP pour la compétition

- » Poids optimisé pour une charge thermique maximale
- » Épaisseur de la piste : 5,5 mm pour l'utilisation des étriers de série
- » Haute stabilité mécanique grâce au système de liaison frette-piste à 10 rivets
- » Liaisons frette-piste entièrement flottante d'un poids optimisé
- » Bague intérieure issue de bloc d'aluminium pour l'industrie aéronautique usinée par CNC
- » Utilisation possible dans toutes les catégories de compétition
- » Frette anodisée noire
- » Design au choix en SP ou RAC-SP
- » Les disques de frein SP ne sont pas homologués pour la route

NEU! NEW! NOUVEAU!



BREMSSCHEIBEN FÜR BMW

BRAKE DISCS FOR BMW DISQUES DE FREINS POUR BMW

Die innovative Konstruktion des Floating-Systems (FS) unterstützt die Lösung von Bremsproblemen. Die voll schwimmend gelagerten Scheiben optimieren Hitzeableitung und beugen einem durch Verzug bedingten Bremsrubbeln vor. Das individuelle Design unterstützt sportliches Bremsverhalten und trägt zur Optimierung der Bremsanlage bei. Die Scheiben sind auch bei ABS-Modellen einsetzbar.

- » innovative Konstruktion
- » Bremsoptimierung
- » hohe Hitzeableitung
- » ansprechendes Design
- » für extreme Beanspruchung
- » auch für ABS Modelle

The innovative design of the Floating System (FS) assists in solving brake problems. The fully floating discs optimise heat dissipation and prevent brake judder caused by warping. The individual design assists sport braking and helps optimise the brake system. The discs can also be used on ABS models.

- » innovative design
- » brake optimisation
- » high heat dissipation
- » attractive design
- » for extreme demands
- » also for ABS models

La construction innovante du système flottant (FS, Floating-System) contribue à la résolution des problèmes de freinage. Les disques entièrement flottants sur palier optimisent l'évacuation de la chaleur et préviennent le frottement des freins dû au voile. Cette conception individuelle confère aux freins un comportement sportif et contribue à l'optimisation du système de freinage. Les disques sont également compatibles avec les modèles équipés de l'ABS.

- » construction innovante
- » optimisation des freins
- » grande capacité d'évacuation de la chaleur
- » design attrayant
- » pour les sollicitations extrêmes
- » également disponible pour les modèles équipés de l'ABS



Floating System (FS) Bremsscheibe im RAC-Design

Floating System disc – RAC design

Disque de frein flottant (FS) – RAC design

**Mit ABE –
kein TÜV nötig!**
*TÜV approved!
TÜV homologué!*



Starre Standard-Bremsscheibe

Fixed disc – standard design

Disque de frein fixe standard



Starre Bremsscheibe im RAC-Design

Fixed disc – RAC design

Disque de frein fixe – RAC design

MONTAGEZUBEHÖR FÜR BMW-SCHEIBEN

ACCESSOIRES DE MONTAGE POUR DISQUES BMW

FITTING KITS FOR BMW DISCS

TRW-Bremsscheibe TRW Brake disc Disque de frein TRW						
	MST238 (RAC) MST356 (RAC)	MST238 (RAC) MST356 (RAC)	MST239 (RAC) MST357 (RAC)	MST239 (RAC) MST357 (RAC)	MST239FS MST357FS	MST239FS MST357FS
Stärke <i>Thickness</i> <i>Épaisseur</i>	4,5 mm	4,5 mm	5 mm	5 mm	5 mm	5 mm
OE-Ausführung <i>OE version</i> <i>Modèle OE</i>	verschraubt <i>bolted</i> <i>vissé</i>	vernietet <i>riveted</i> <i>riveté</i>	verschraubt <i>bolted</i> <i>vissé</i>	vernietet <i>riveted</i> <i>riveté</i>	verschraubt <i>bolted</i> <i>vissé</i>	vernietet <i>riveted</i> <i>riveté</i>
Baujahr <i>Year of manufacture</i> <i>Année de construction</i>	- 11/2007	12/2007 -	- 11/2007	12/2007 -	- 11/2007	12/2007 -
Montagezubehör <i>Fitting kit</i> <i>Accessoire de montage</i>	OE optional MST13FK	MST14FK	OE optional MST15FK	MST16FK	nicht nötig <i>not necessary</i> <i>inutile</i>	MST12FK
Schrauben <i>Bolts</i> <i>Vis</i>	OE	OE	OE	OE	OE	OE
Einbauhinweis <i>Installation information</i> <i>Consigne de montage</i>						

OE = Originalteile | OE = Original Equipment | OE = Pièces d'origine

Inhalte | Contents | Contenus





Option 1

Option 2



Option 1

Option 2



Adly

RT	50 Road Tracer		04-06		MST 250			155				
SS	50 Super Sonic		04-05		MST 243	RAC		190				
RT	90 Road Tracer		02-06		MST 250			155				
RT	100 Road Tracer		02-06		MST 250			155				
SS	100 Super Sonic	SS-100	04-05		MST 243	RAC		190				
SS	125 Super Sonic		04-		MST 243	RAC		190				
TB	125 Thunderbike	TB-125			MST 243	RAC		190				

Aprilia

	50 Amico	GC	92-		MST 250			155				
	50 Amico GL	HU	93-98		MST 250			155				
	50 Area 51	MY	98-02						MST 236	RAC		190
	50 Gulliver AC	LH02	95-00		MST 236	RAC		190				
	50 Gulliver LC	LH	97-00		MST 236	RAC		190				
	50 Habana	PK	98-02		MST 236	RAC		190				
	50 Mojito/ Mojito custom	PK	03-10		MST 236	RAC		190				
	50 Rally AC	MD01	95-02		MST 236	RAC		190				
	50 Rally LC	MD01	96-98		MST 236	RAC		190				
	50 Rally LC	MD	97-01		MST 236	RAC		190	MST 236	RAC		190
	50 Scarabeo de lux	PF	98-99		MST 253			220	MST 236	RAC		190
	50 Scarabeo Ditech	SC	02-06						MST 236	RAC		190
	50 Sonic LC, AC	PB	99-08		MST 250			155				
	50 Sport City 4T	SB	08-09		MST 254			220				
	50 Sport City One 2T	SB	08-11		MST 254			220				
SR	50 Ditech	RL	00-03		MST 236	RAC		190	MST 236	RAC		190
SR	50 Ditech LC	LC	02-03		MST 236	RAC		190	MST 236	RAC		190
SR	50 AC	MR	93-96		MST 236	RAC		190				
SR	50 AC	LB	92-94		MST 236	RAC		190				
SR	50 AC	LY	97-02		MST 236	RAC		190				
SR	50 Motard	LB	12-		MST 254			220				
SR	50 LC	LC	93-97		MST 236	RAC		190	MST 236	RAC		190
SR	50 LC	MZ	97-99		MST 236	RAC		190	MST 236	RAC		190
SR	50 LC	MR	93-00		MST 236	RAC		190	MST 236	RAC		190
SR	50 LC Sport	RL	00-02		MST 236	RAC		190	MST 236	RAC		190
SR	50 R Factory LC	VF	04-		MST 236	RAC		190	MST 236	RAC		190
SR	50 R	VF	10-		MST 236	RAC		190				
SR	50 Stealth LC	LC	96-00		MST 236	RAC		190	MST 236	RAC		190
SR	50 Street LC	TE	03-		MST 236	RAC		190	MST 236	RAC		190
SR	50 www	LY	97-01		MST 236	RAC		190				
	125 Atlantic	SP	03-10						MST 236	RAC		190
	125 Habana	PM	00-02		MST 236	RAC		220				
	125 Mojito	RY	02-		MST 236	RAC		220				
	125 Mojito custom	RY	02-		MST 236	RAC		220				
	125 Leonardo	MB00	96-04		MST 253			220	MST 236	RAC		190
	125 Leonardo	TB	05-		MST 253			220				
	125 Pegaso	ET	91-95		MST 337			298				
	125 Scarabeo	PF	99-03		MST 253			220	MST 236	RAC		190
	125 Scarabeo	TD	04-07		MST 253			220	MST 253			220
	125 Scarabeo	VR	07-10		MST 409			260	MST 253			220
	125 Sport City	VB	04-08		MST 409			260	MST 253			220
	125 Sport City Cube	VB	08-		MST 409			260	MST 253			220
	125 Sport City One	SG	08-11		MST 254			220				
	125 Tuono		03-04		MSW 211	RAC		320				
AF1	125 Futura	FM	89-92		MSW 211	RAC		320				
MX	125 Supermoto	TZ	03-07		MSW 211	RAC		320				
RS	125 Extrema/Replica	GS	92-94		MSW 211	RAC		320				
RS	125 Extrema/Replica	MP	95-01		MSW 211	RAC		320				
RS	125 Extrema/Replica	SF	02-05		MSW 211	RAC		320				
RS	125 Extrema/Replica	RD/RM	06-09		MSW 211	RAC		320				
RS	125 Extrema/Replica	PY	10-13		MSW 211	RAC		320				
RS	125 Alitalia		11-		MSW 211	RAC		320				
SR	125	PX	99-02		MST 236	RAC		190				
SR	125 Max i.e.	M35	11-		MST 393			260	MST 395			240
SR	125 Motard		12-		MST 254			220				



* 2 Scheiben erforderlich – 2 discs required
 EX starre Scheibenausführung – fixed disc

☑ linke Seite – left side
 ☑ rechte Seite – right side



Option 1

Option 2



Option 1

Option 2



Aprilia											
	150 Leonardo	MB	97-04		MST 253			220	MST 236	RAC	190
SR	150	PX	00-02		MST 236	RAC		190			
	150 Scarabeo	SD	99-06		MST 253			220	MST 253		220
	200 Atlantic	SP	03-05						MST 236		190
	200 Sport City	VB	04-08		MST 409			260	MST 253		220
	200 Sport City Cube	VB	08-09		MST 409			260	MST 253		220
	250 Leonardo	PD	99-04		MST 253			220			
	250 Leonardo	SV	05-		MST 253			220			
	250 Scarabeo i.e.	VR	06-10		MST 253			220	MST 253		220
	250 Sport City i.e.	VB	06-08		MST 409			260	MST 253		220
	250 Sport City Cube	VB	08-09		MST 409			260	MST 253		220
	300 Leonardo	SV	05-06		MST 253			220			
	300 Scarabeo S	VR	09-10		MST 409			260			
	300 Sport City Cube	VB	08-		MST 409			260	MST 253		220
	300 Sport Cube Blackline	VB	11		MST 409			260	MST 253		220
SR	300 Max i.e.	M35	11-		MST 393			260	MST 395		240
	400 Scarabeo ie	VR	07-08		MST 409			260			
SXV	450	VS	05-		MSW 270 RAC			320			
	500 Atlantic, Sprint	VL	02-08		MST 409			260			
	500 Scarabeo ABS	VR	03-06		MST 409			260			
	500 Scarabeo ie	VR	07-09		MST 409			260			
SXV	550	VS	05-		MSW 270 RAC			320			
	600 Pegaso	EP/FP	89-91		MST 337			298			
	650 Pegaso	GA	91-95		MST 337			298			
	650 Pegaso	ML/MX	96-04		MST 337			298			
	650 Pegaso i.e.	RW	01-04		MST 337			298			
	650 Pegaso Factory	VD	07-10	*	MSW 211	RAC		320			
	650 Pegaso Trial	VD	05-08		MST 337			298			
	650 Pegaso Strada	VD	05-10	*	MSW 211	RAC		320			
SL	750 Shiver	RA	07-10	*	MSW 211	RAC		320	MST 376 RAC		220
SL	750 Shiver, ABS	RA	11-	*	MSW 211	RAC		320	MST 430		245
SMV	750 Dorsoduro, ABS	SM	09-	*	MSW 211	RAC		320	MST 430		245
NA	850 Mana, ABS	RC	07-11	*	MSW 211	RAC		320	MST 431		260
NA	850 Mana GT, ABS	RC	10-	*	MSW 211	RAC		320	MST 431		260
SRV	850 , ABS	M55	12-	*	MST 458			300	MST 459		280
RST	1000 Futura	PW	01-	*	MSW 221	RAC		298			
RSV	1000 Mille	ME	98-00	*	MSW 211	RAC		320	MST 376 RAC		220
RSV	1000 Mille R, SP	RP	01-03	*	MSW 211	RAC		320	MST 376 RAC		220
RSV	1000 R, R Factory	RR	04-08	*	MSW 211	RAC		320	MST 376 RAC		220
RSV4	1000 R, Factory	RK	09-10	*	MSW 211	RAC		320	MST 376 RAC		220
RSV4	1000 R, Factory APRC, ABS	RK	11-	*	MSW 211	RAC		320	MST 429 RAC		220
RSV4	1000 RR ABS		15-	*	MSW 211	RAC		320	MST 429 RAC		220
RSV4	1000 RF ABS		15-	*	MSW 211	RAC		320	MST 429 RAC		220
RSV	1000 Touno R	RP	02-06	*	MSW 211	RAC		320	MST 376 RAC		220
RSV	1000 Touno R Factory	RR	06-10	*	MSW 211	RAC		320	MST 376 RAC		220
V4R	1000 Touno, Touno APRC	RK	11-	*	MSW 211	RAC		320	MST 429 RAC		220
SL	1000 Falco	PA	00-05	*	MSW 211	RAC		320	MST 376 RAC		220
ETV	1200 Caponord, ABS	VK	13-	*	MSW 211	RAC		320	MST 430		245
SMV	1200 Dorsoduro ATC/ABS	TV	11-	*	MSW 211	RAC		320	MST 430		245
Arctic Cat											
DVX	50	DVX50	06-		MST 256			180	MST 256		180
DVX	90	DVX90	06-		MST 256			180	MST 256		180
Atala											
	50 Hacker		97		MST 252	RAC		190			
Benelli											
	50 Naked	ND	01-03		MST 252	RAC		190	MST 252	RAC	190
	50 Pepe LX	SP	99-		MST 396			220			
491	50 RR, GP	BA01	00-04		MST 252	RAC		190	MST 252	RAC	190
491	50 Sport, GT, SBK	BA01	97-04		MST 252	RAC		190	MST 252	RAC	190
K2	50 AC, LC	BA01	98-01		MST 252	RAC		190	MST 252	RAC	190
K2	100	BA01	98-01		MST 252	RAC		190	MST 252	RAC	190
	100 Naked	ND	02		MST 252	RAC		190	MST 252	RAC	190
	125 Adiva	D1	00-04		MST 254			220			
	125 Velvet	M1	99-07						MST 252	RAC	190



Option 1

Option 2



Option 1

Option 2

**Benelli**

	150 Adiva	D1	00-04		MST 254		220			
BX	450 Cross		07-		MST 265	RAC	260	MST 266	RAC	220
BN	600 GT	P25	14-	*	MSW 211	RAC	320			
BN	600 R	P25	14-	*	MSW 211	RAC	320			
	899 Century Racer		11-	*	MSW 211	RAC	320			
TNT	899 Sport	TN	08-	*	MSW 211	RAC	320			
TreK	899	TK	07-12	*	MSW 211	RAC	320			
	900 Tornado TRE	TB	02-	*	MSW 211	RAC	320			
	1130 Tornado TRE	TK	06-10	*	MSW 211	RAC	320	MST 330		240
TreK	1130 Amazonas	TK	07-	*	MSW 211	RAC	320	MST 330		240
	1130 Century Racer	TN	11-12	*	MSW 211	RAC	320			
TNT	1130 Cafe Racer	TN	05-12	*	MSW 211	RAC	320	MST 330		240
TNT	1130 Sport, Sport Evo	TN	05-09	*	MSW 211	RAC	320	MST 330		240

Beta

	50 Eikon	BS	99-06		MST 252	RAC	190	MST 252	RAC	190
	50 Quadra	KTM GO 50	97-00		MST 252	RAC	190	MST 252	RAC	190
	50 Chrono	KTM GO 50	94-		MST 236	RAC	190			
	50 Tempo 13	KTM GO 50	95-02		MST 252	RAC	190	MST 252	RAC	190
ARK	50 AC	BS	96-		MST 252	RAC	190			
ARK	50 LC	BS	97-		MST 252	RAC	190	MST 252	RAC	190
	125 Eikon	S7	99-		MST 254		220			
	150 Eikon	S7	99-		MST 254		220			

Bimota

	500 V-Due	VT5	97-00		MSW 211	RAC	320			
BB1	650 Supermono	BB1	96-00		MSW 211	RAC	320			
	851 Tesi	T1D	90-91		MSW 211	RAC	320			
DB3	900 Mantra	DB3	96-00	*	MSW 211	RAC	320			
DB4	900	DB4	98-99	*	MSW 211	RAC	320			
DB2	900 SR	DB2	94-00		MSW 211	RAC	320			
DB6	1000 Delirio	DB06	07-08	*	MSW 211	RAC	320			
	1000 Dieci Biposto	YB8	92-95		MSW 211	RAC	320			
SB8R	1000	SB8R	99-01	*	MSW 211	RAC	320			
DB7	1100	DB07	08-10	*	MSW 211	RAC	320			
SB6	1100	SB6	96-00	*	MSW 211	RAC	320			
SB6R	1100	SB6R	98-00	*	MSW 211	RAC	320			
DB8	1200	DB08	10-	*	MSW 211	RAC	320			
DB11	1200	DB11	13-	*	MSW 211	RAC	320			

BMW

G	450 X	E45X	08-		MST 418 RAC		260			
C	600 Sport ABS	C65	11-		MST 456		270	MST 456		270
C	650 GT ABS	C65	11-		MST 456		270	MST 456		270
F650	650	169	94-00		MST 337		298	MST 330		240
F650	650 ABS	169	94-00		MST 337		298	MST 330		240
F650	650 ST	169	97-99		MST 387		298	MST 330		240
F650	650 CS	169	93-00		MST 337	RAC	298	MST 330		240
F650	650 CS	K14	00-05		MST 337	RAC	298	MST 330		240
F650	650 CS	E650C	03-06		MST 337	RAC	298	MST 330		240
F650	650 CS ABS	K14	00-05		MST 337	RAC	298	MST 330		240
F650	650 CS ABS	E650C	03-06		MST 337	RAC	298	MST 330		240
F650	650 GS	R13	00-03		MST 337	RAC	298	MST 330		240
F650	650 GS ABS	R13	00-03		MST 337	RAC	298	MST 330		240
F650	650 GS	E650G	04-07		MST 337	RAC	298	MST 330		240
F650	650 GS ABS	E650G	04-07		MST 337	RAC	298	MST 330		240
F650	650 GS Dakar	R13	00-03		MST 337	RAC	298	MST 330		240
F650	650 GS Dakar	E650G	04-07		MST 337	RAC	298	MST 330		240
F650	650 GS Dakar ABS	E650G	04-07		MST 337	RAC	298	MST 330		240
G	650 GS	E650G	08-		MST 337	RAC	298	MST 330		240
G	650 GS ABS	E650G	08-		MST 337	RAC	298	MST 330		240
G	650 GS Sertao	E650G	10-		MSW 253		300	MST 330		240
G	650 GS Sertao ABS	E650G	10-		MSW 253		300	MST 330		240
G	650 Xchallenge	E65X	07-10		MST 337	RAC	298			



* 2 Scheiben erforderlich – 2 discs required
 EX starre Scheibenausführung – fixed disc

linke Seite – left side
 rechte Seite – right side



Option 1

Option 2



Option 1

Option 2



BMW															
G	650 Xcountry	E65X	07-10						MST 337	RAC	298				
G	650 Xmoto	E65X	07-10						MSW 211	RAC	320	MST 330			240
F650	800 GS	E8GS	08-12						MSW 253		300	MST 372	RAC		265
F650	800 GS ABS	E8GS	08-12						MSW 253		300	MST 372	RAC		265
F650	800 GS Dakar	E8GS	08-12						MSW 253		300	MST 372	RAC		265
F650	800 GS Dakar ABS	E8GS	08-12						MSW 253		300	MST 372	RAC		265
F700	800 GS ABS	E8GS	13-				*		MSW 253		300	MST 372	RAC		265
F800	800 GS ABS	E8GS	08-				*		MSW 253		300	MST 372	RAC		265
F800	800 GT ABS	E8ST	13-	4), 5)			*		MST 357	RAC	FS	320	MST 372	RAC	265
F800	800 R	E8ST	09-	2), 5)			*		MST 356	RAC	FS	320	MST 372	RAC	265
F800	800 R ABS	E8ST	09-	2), 5)			*		MST 356	RAC	FS	320	MST 372	RAC	265
F800	800 S, ST	E8ST	04-07	1)					MST 356	RAC	FS	320	MST 372	RAC	265
F800	800 S ABS, ST ABS	E8ST	04-07	1)					MST 356	RAC	FS	320	MST 372	RAC	265
F800	800 S, ST	E8ST	08-12	2), 5)					MST 356	RAC	FS	320	MST 372	RAC	265
F800	800 S ABS, ST ABS	E8ST	08-12	2), 5)					MST 356	RAC	FS	320	MST 372	RAC	265
R	850 C	259C	97-00	3)			*		MST 239	RAC	FS	305			
R	850 C ABS	259C	97-00	3)			*		MST 239	RAC		305			
R	850 GS	259	97-99	3)			*		MST 239	RAC	FS	305	MST 331	RAC	276
R	850 GS ABS	259	97-99	3)			*		MST 239	RAC	FS	305	MST 331	RAC	276
R	850 GS	R21	99-00	3)			*		MST 239	RAC	FS	305	MST 331	RAC	276
R	850 GS ABS	R21	99-00	3)			*		MST 239	RAC	FS	305	MST 331	RAC	276
R	850 RT	259	95-01				*		MSW 200			305	MST 331	RAC	276
R	850 RT Intergral ABS	R22	01-06	3)			*		MST 357	RAC	FS	320			
R	850 R	259	95-00				*		MSW 200			305			
R	850 R ABS	259	95-00				*		MSW 200			305			
R	850 R (Spoke wheel)	259	94-00	3)			*		MST 239	RAC		305	MST 331	RAC	276
R	850 R	R21	00-03	3)			*		MST 239	RAC	FS	305	MST 331	RAC	276
R	850 R ABS	R21	00-03	3)			*		MST 239	RAC	FS	305	MST 331	RAC	276
R	850 R	R11R	04-07	3)			*		MST 357	RAC	FS	320	MST 331	RAC	276
R	850 R ABS	R11R	04-07	3)			*		MST 357	RAC	FS	320	MST 331	RAC	276
K1	1000	100	89-93				*		MSW 200			305			
K1	1000 ABS	100	89-93				*		MSW 200			305			
K	1000 RS (16V), ABS	100	89-92				*		MSW 200			305			
S	1000 RR HP4 ABS	K10	13-				*		MSW 288 RAC			320	MST 392	RAC	220
S	1000 RR HP4 ABS	K10	13-	Racing only					MSW 288 SP-L			320	MST 392	RAC	220
S	1000 RR HP4 ABS	K10	13-	Racing only					MSW 288 SP-R			320	MST 392	RAC	220
S	1000 RR	K10	09-	4), 5)			*		MST 357	RAC	FS	320	MST 392	RAC	220
S	1000 RR ABS	K10	09-	4), 5)			*		MST 357	RAC	FS	320	MST 392	RAC	220
S	1000 RR ABS	K10	09-	Racing only			*		MSW 357 SP	RAC-SP		320	MST 392	RAC	220
S	1000 R ABS	K10	14-	4), 5)			*		MST 357	RAC	FS	320	MST 392	RAC	220
S	1000 XR ABS		15-	4), 5)			*		MST 357	RAC	FS	320	MST 372	RAC	265
K	1100 RS	BMW100	92-99				*		MSW 200			305			
K	1100 LT	BMW100	92-96				*		MSW 200			305			
R	1100 GS	259	93-99	3)			*		MST 239	RAC	FS	305	MST 331	RAC	276
R	1100 GS ABS	259	93-99	3)			*		MST 239	RAC	FS	305	MST 331	RAC	276
R	1100 S	R2S	98-00	1)			*		MST 238	RAC	239FS	305	MST 331	RAC	276
R	1100 S ABS	R2S	98-00	1)			*		MST 238	RAC	239FS	305	MST 331	RAC	276
R	1100 S	R2S	01-03	3)			*		MST 357	RAC	FS	320	MST 331	RAC	276
R	1100 S ABS	R2S	01-03	3)			*		MST 357	RAC	FS	320	MST 331	RAC	276
R	1100 S	R11S	04-05	3)			*		MST 357	RAC	FS	320	MST 331	RAC	276
R	1100 S Integral ABS	R11S	04-05	3)			*		MST 357	RAC	FS	320	MST 331	RAC	276
R	1100 RS	259	92-01				*		MSW 200			305			
R	1100 RS ABS	259	98-01				*		MSW 200			305			
R	1100 R	259R	93-01				*		MSW 200			305	MST 331	RAC	276
R	1100 R ABS	259R	98-01				*		MSW 200			305	MST 331	RAC	276

			Stärke / thickness	OE Ausführung / OE finish		Montageset beachten / consider the fittingkits	
1)	MST238 / MST356 (RAC)		4,5mm	verschraubt / loose bobbins	- 11/07	MST13FK	OE
2)	MST238 / MST356 (RAC)		4,5mm	vernietet / fixed bobbins	12/07 -	MST14FK	OE
3)	MST239 / MST357 (RAC)		5mm	verschraubt / loose bobbins	- 11/07	MST15FK	OE
4)	MST239 / MST357 (RAC)		5mm	vernietet / fixed bobbins	12/07 -	MST16FK	OE
	MST239FS / MST357FS		5mm	verschraubt / loose bobbins	- 11/07	nicht nötig, not necessary	OE
5)	MST239FS / MST357FS		5mm	vernietet / fixed bobbins	12/07 -	MST12FK	OE



Option 1

Option 2



Option 1

Option 2



BMW

R	1100 RT	259	94-01		*	MSW 200			305	MST 331	RAC		276
R	1100 RT Intergral ABS	259	94-01		*	MST 239	RAC		305	MST 331	RAC		276
R	1150 GS	R21	98-03	3)	*	MST 239	RAC		305	MST 331	RAC		276
R	1150 GS Evo ABS	R21	98-03	3)	*	MST 239	RAC		305	MST 331	RAC		276
R	1150 GS	R21/R11R	04-05	3)	*	MST 239	RAC	FS	305	MST 331	RAC		276
R	1150 GS ABS	R21/R11R	04-05	3)	*	MST 239	RAC	FS	305	MST 331	RAC		276
R	1150 GS Adventure	R21/R11R	02-05	3)	*	MST 239	RAC	FS	305	MST 331	RAC		276
R	1150 GS Adventure ABS	R21/R11R	02-05	3)	*	MST 239	RAC	FS	305	MST 331	RAC		276
R	1150 R	R21	00-03	3)	*	MST 357	RAC	FS	320	MST 331	RAC		276
R	1150 R ABS	R11R	04-06	3)	*	MST 357	RAC	FS	320	MST 331	RAC		276
R	1150 RT Intergral ABS	R22	00-03	3)	*	MST 357	RAC	FS	320	MST 331	RAC		276
R	1150 RT Intergral ABS	R11RT	04-06	3)	*	MST 357	RAC	FS	320	MST 331	RAC		276
R	1150 RS Intergral ABS	R22	00-04	3)	*	MST 357	RAC	FS	320	MST 331	RAC		276
R	1150 RS Intergral ABS	R11RT	04	3)	*	MST 357	RAC	FS	320	MST 331	RAC		276
R	1200 nineT	R1ST	14-	2) 5)	*	MST 356	RAC	FS	320	MST 372	RAC		265
K	1200 GT	K12	02-05	3)	*	MST 357	RAC	FS	320				
K	1200 GT	K12S	06-08	3)	*	MST 357	RAC	FS	320	MST 391			294
K	1200 LT	K2LT	98-99	3)	*	MST 239	RAC	FS	305				
K	1200 LT ABS	K2LT	98-99	3)	*	MST 239	RAC	FS	305				
K	1200 LT	K2LT	99-09	3)	*	MST 357	RAC	FS	320				
K	1200 LT Intergral ABS	K2LT	99-09	3)	*	MST 357	RAC	FS	320				
K	1200 RS	589	97-00	3)	*	MST 239	RAC		305				
K	1200 RS ABS	589	97-00	3)	*	MST 239	RAC		305				
K	1200 RS	K12	00-05	3)	*	MST 357	RAC	FS	320				
K	1200 RS Intergral ABS	K12	00-05	3)	*	MST 357	RAC	FS	320				
K	1200 S	K12S	03-08	3)	*	MST 357	RAC	FS	320	MST 372	RAC		265
K	1200 S Intergral ABS	K12S	03-08	3)	*	MST 357	RAC	FS	320	MST 372	RAC		265
K	1200 R	K12R	04-08	3)	*	MST 357	RAC	FS	320	MST 372	RAC		265
K	1200 R ABS	K12R	04-08	3)	*	MST 357	RAC	FS	320	MST 372	RAC		265
R	1200 C	259C	97-01	3)	*	MST 239	RAC	FS	305				
R	1200 C ABS	259C	97-00	3)	*	MST 239	RAC		305				
R	1200 C	R2C	01-05	3)	*	MST 239	RAC	FS	305				
R	1200 C ABS	R2C	01-05	3)	*	MST 239	RAC	FS	305				
R	1200 CL	K30	03-06	3)	*	MST 239	RAC	FS	305				
R	1200 CL ABS	K30	03-06	3)	*	MST 239	RAC	FS	305				
R	1200 GS	R12	03-07	1)	*	MST 238	RAC	239FS	305	MST 372	RAC		265
R	1200 GS ABS	R12	03-07	1)	*	MST 238	RAC	239FS	305	MST 372	RAC		265
R	1200 GS Adventure	R12	03-07	1)	*	MST 238	RAC	239FS	305	MST 372	RAC		265
R	1200 GS Adventure ABS	R12	03-07	1)	*	MST 238	RAC	239FS	305	MST 372	RAC		265
R	1200 GS	R12	08-12	2), 5)	*	MST 238	RAC	239FS	305	MST 372	RAC		265
R	1200 GS ABS	R12	08-12	2), 5)	*	MST 238	RAC	239FS	305	MST 372	RAC		265
R	1200 GS Adventure	R12	08-12	2), 5)	*	MST 238	RAC	239FS	305	MST 372	RAC		265
R	1200 GS Adventure ABS	R12	08-12	2), 5)	*	MST 238	RAC	239FS	305	MST 372	RAC		265
R	1200 GS ABS	R12W	13-	2), 5)	*	MST 238	RAC	239FS	305	MST 464	RAC		276
R	1200 GS Adventure ABS	R12W	13-	2), 5)	*	MST 238	RAC	239FS	305	MST 464	RAC		276
R	1200 HP2 Enduro	RHP2	04-06	3)	*	MST 239	RAC	FS	305	MST 372	RAC		265
R	1200 HP2 Megamoto	RHP2	07-08	1)	*	MST 356	RAC	357FS	320	MST 372	RAC		265
R	1200 HP2 Sport	R12S	08-10	2), 5)	*	MST 356	RAC	357FS	320	MST 372	RAC		265
R	1200 HP2 Sport ABS	R12S	08-10	2), 5)	*	MST 356	RAC	357FS	320	MST 372	RAC		265
R	1200 RT	R12T	03-07	1)	*	MST 356	RAC	357FS	320	MST 372	RAC		265
R	1200 RT ABS	R12T	03-07	1)	*	MST 356	RAC	357FS	320	MST 372	RAC		265
R	1200 RT	R12T	08-	2), 5)	*	MST 356	RAC	357FS	320	MST 372	RAC		265
R	1200 RT ABS	R12T	08-	2), 5)	*	MST 356	RAC	357FS	320	MST 372	RAC		265
R	1200 R	R1ST	05-07	1)	*	MST 356	RAC	357FS	320	MST 372	RAC		265
R	1200 R ABS	R1ST	05-07	1)	*	MST 356	RAC	357FS	320	MST 372	RAC		265
R	1200 R	R1ST	08-	2), 5)	*	MST 356	RAC	357FS	320	MST 372	RAC		265
R	1200 R ABS	R1ST	08-	2), 5)	*	MST 356	RAC	357FS	320	MST 372	RAC		265
R	1200 Classic	R1ST	05-07	1)	*	MST 356	RAC	357FS	320	MST 372	RAC		265
R	1200 Classic ABS	R1ST	05-07	1)	*	MST 356	RAC	357FS	320	MST 372	RAC		265
R	1200 Classic	R1ST	08-	2), 5)	*	MST 356	RAC	357FS	320	MST 372	RAC		265
R	1200 Classic ABS	R1ST	08-	2), 5)	*	MST 356	RAC	357FS	320	MST 372	RAC		265
R	1200 S	R12S	04-06	1)	*	MST 356	RAC	357FS	320	MST 372	RAC		265
R	1200 S ABS	R12S	04-06	1)	*	MST 356	RAC	357FS	320	MST 372	RAC		265



* 2 Scheiben erforderlich – 2 discs required
 EX starre Scheibenausführung – fixed disc

☑ linke Seite – left side
 ☑ rechte Seite – right side



Option 1

Option 2



Option 1

Option 2



BMW												
R	1200 ST	R1ST	03-07	1)	*	MST 356	RAC	357FS	320	MST 372	RAC	265
R	1200 ST ABS	R1ST	03-07	1)	*	MST 356	RAC	357FS	320	MST 372	RAC	265
K	1300 GT ABS	K12S	08-11	4), 5)	*	MST 357	RAC	FS	320	MST 391		294
K	1300 R	K12S	07-	4), 5)	*	MST 357	RAC	FS	320	MST 372	RAC	265
K	1300 R ABS	K12S	07-	4), 5)	*	MST 357	RAC	FS	320	MST 372	RAC	265
K	1300 S	K12S	09-	4), 5)	*	MST 357	RAC	FS	320	MST 372	RAC	265
K	1300 S ABS	K12S	09-	4), 5)	*	MST 357	RAC	FS	320	MST 372	RAC	265
K	1600 GT ABS, GTL ABS	K16GT	11-	4), 5)	*	MST 357	RAC	FS	320			
Bombardier												
DS	650 Baja X	A	00-06			MST 400			165	MST 401		196
Cagiva												
	50 City	4P	07-			MST 243	RAC		190			
	50 City	4P	92-			MST 241			162			
	110 Passing	6P	94-			MST 241			162			
	125 Freccia	C12	89-91			MSW 221	RAC		300			
	125 Mito 1, Mito 2	8P	91-94			MSW 211	RAC		320			
	125 Mito EVO	8P	95-08			MSW 211	RAC		320			
	125 Mito SP525	N3	08-11			MSW 211	RAC		320			
	125 Raptor	N3	03-11			MSW 211	RAC		320			
	125 Supercity	2F	92-01			MSW 211	RAC		320			
N1	125 Planet	N1	97-04			MSW 211	RAC		320			
	500 Canyon		96-00			MST 206			296			
	600 Canyon	5G1	96-99			MST 206			296			
	500 Mito		07-			MSW 211	RAC		320			
	600 River	3G	94-98		*	MSW 211	RAC		320			
	750 Elefant	B	94-97			MST 206	RAC		296			
	900 Elefant I.E.	B	90-92			MST 206	RAC		296			
	900 Canyon	M3	97-99		*	MST 206	RAC		296	MST240	RAC	245
	1000 Navigator	M5	00-05		*	MST 206	RAC		296	MST240	RAC	245
	1000 Raptor X3	M2	03-04		*	MSW 211	RAC		320			
CPI												
	50 Baby		02-			MST 243	RAC		190			
	50 Popcorn	JP	02-06			MST 243	RAC		190			
	50 Oliver	JR	03-06			MST 243	RAC		190			
	50 Hussar	JR	01-05			MST 243	RAC		190			
Derbi												
	50 Atlantis 2T AC	AL	07-11	12"		MST 260	RAC		200			
	50 Atlantis 4T	AL	07-09	13"		MST 260	RAC		200			
	50 Boulevard	BR	09-			MST 260	RAC		200			
GP1	50 Race	PR	05-07			MST 255			174	MST 255		174
GPI	50 Open	GR	06-11			MST 396			220	MST 255		174
	50 Hunter	Hunt	96-99			MST 243	RAC		190			
ST	50 Paddock AC, LC	Hunt	96-99			MST 243	RAC		190			
	50 Predator LC	Pred	98-03			MST 243	RAC		190	MST 243	RAC	
	100 Predator	Pred	98-03			MST 243	RAC		190			
	125 Boulevard	BL	03-07			MST 254			220			
	125 Boulevard S	M57	07			MST 409			260	MST 253		220
	125 Boulevard 4T	M57	08-			MST 260	RAC		200			
	125 Rambla	RA	08-			MST 409			260	MST 253		220
GP1	125 Racing		07-09							MST 396		220
GP1	250 Racing		07-09							MST 396		220
	150 Boulevard		03-07			MST 254			220			
	200 Boulevard		05			MST 254			220			
	250 Rambla i	RA	08-09			MST 409			260			
	300 Rambla i	RA	10-			MST 409			260			
DXR	200		04-			MST 405			161	MST 407		220
DXR	250		04-			MST 405			161	MST 407		220



Ducati											
	400 Monster	M	00-04		MSW 211	RAC		320	MST 247	RAC	245
	400 Monster Dark i.e.	M	05-06		MSW 211	RAC		320	MST 247	RAC	245
	400 SS	S	93-97		MSW 211	RAC		320	MST 247	RAC	245
	600 Monster	M	94-01		MSW 211	RAC		320	MST 247	RAC	245
	600 SS	600S	94-98		MSW 211	RAC		320	MST 247	RAC	245
	620 Monster i.e., Dark	M4	02-07		MSW 211	RAC		320	MST 247	RAC	245
	620 Multistrada	A1	05-06		MSW 211	RAC		320	MST 247	RAC	245
	620 Sport	V5	03-04		MSW 211	RAC		320	MST 247	RAC	245
	695 Monster	M4	06-08	*	MSW 211	RAC		320	MST 247	RAC	245
	696 Monster	M5	08-	*	MSW 211	RAC		320	MST 283 RAC		245
	696 Monster ABS	M5	08-	*	MSW 211	RAC		320	MST 283 RAC		245
	748 SP	748S	95-96	*	MSW 211	RAC		320			
	748 Biposto	748	95-98	*	MSW 211	RAC		320			
	748 Biposto	H3	99-02	*	MSW 211	RAC		320			
	748 SPS	748S	98-99	*	MSW 211	RAC		320			
	748 S	748S	00-02	*	MSW 211	RAC		320			
	748 R	748S	00-02	*	MSW 211	RAC		320			
	749	H5	03-07	*	MSW 267 RAC			320	MST 419 RAC		240
	749 R	H5	03-07	*	MSW 267 RAC			320	MST 419 RAC		240
	749 S	H5	03-07	*	MSW 267 RAC			320	MST 419 RAC		240
	750 Sport	750S	01-02	*	MSW 211	RAC		320	MST 247	RAC	245
	750 SS	S	91-02	*	MSW 211	RAC		320	MST 247	RAC	245
	750 Monster	M	96-02	*	MSW 211	RAC		320	MST 247	RAC	245
	750 Monster i.e.	M	96-02	*	MSW 211	RAC		320	MST 247	RAC	245
	796 Hypermotard	B1	10-12	*	MSW 281 RAC			305	MST 377 RAC		245
	796 Monster	M5	11-	*	MSW 285 RAC			320	MST 420 RAC		245
	796 Monster ABS	M5	11-	*	MSW 285 RAC			320	MST 420 RAC		245
	800 Monster i.e.	M	02-05	*	MSW 211	RAC		320	MST 247	RAC	245
S2R	800 Monster	M4	06-07	*	MSW 211	RAC		320	MST 377 RAC		245
	800 Sport, Supersport	V5	03-05	*	MSW 211	RAC		320	MST 247	RAC	245
	800 Scrambler		15-						MST 283 RAC		245
	821 Hypermotard, SP	B2	13-	*	MSW 267 RAC			320	MST 420 RAC		245
	821 Hypermotard, SP ABS	B2	13-	*	MSW 267 RAC			320	MST 420 RAC		245
	821 Hyperstrada	B2	13-	*	MSW 267 RAC			320	MST 420 RAC		245
	821 Hyperstrada ABS	B2	13-	*	MSW 267 RAC			320	MST 420 RAC		245
	821 Monster ABS	M6	14-	*	MSW 267 RAC			320	MST 283 RAC		245
	848	H6	08-10	*	MSW 267 RAC			320	MST 377 RAC		245
	848 Evo	H6	11-	*	MSW 267 RAC			320	MST 377 RAC		245
	848 Evo Corse SE	H6	12-	*	MSW 280 RAC			330			
	848 Streetfighter	F1	11-						MST 377 RAC		245
	851 S	ZDM851S3...	88-90	*	MSW 211	RAC		320	MST 247	RAC	245
	851 Strada	ZDM851S3...	91-92	*	MSW 211	RAC		320			
	888 SP, SP2, SP3	ZDM888S...	89-91	*	MSW 211	RAC		320	MST 247	RAC	245
	888 SP4, SP5	ZDM888S...	92-	*	MSW 211	RAC		320			
	888 Strada	ZDM888S...	93-94	*	MSW 211	RAC		320	MST 247	RAC	245
	899 Panigale ABS	H8	13-	*	MSW 267 RAC			320	MST 283 RAC		245
	899 Panigale ABS	H8	13-	Racing only	MSW 267 SP	RAC-SP		320	MST 283 RAC		245
	900 Monster	M	93-99	*	MSW 211	RAC		320	MST 247	RAC	245
	900 Monster i.e.	M2	00-02	*	MSW 211	RAC		320	MST 247	RAC	245
	900 Sport, Supersport i.e.	V1	02	*	MSW 211	RAC		320	MST 247	RAC	245
	900 SS Supersport	S	91-02	*	MSW 211	RAC		320	MST 247	RAC	245
	900 Superlight	ZDM906SC2...	91-97	*	MSW 211	RAC		320	MST 247	RAC	245
S4	900 Monster	M4	00-04	*	MSW 211	RAC		320	MST 247	RAC	245
	907 Paso i.e.		90-91	*	MSW 221			300			
	916 Strada	916	94-97	*	MSW 211	RAC		320			
	916 Biposto	916	94-98	*	MSW 211	RAC		320			
	916 SPS	916	97-98	*	MSW 211	RAC		320			
ST4	916	S2	99-02	*	MSW 211	RAC		320	MST 247	RAC	245
ST2	944	S1	97-03	*	MSW 211	RAC		320	MST 247	RAC	245
	989 Desmosedici RR	D1	07-09	*	MSW 280 RAC			330	MST 377 RAC		245
ST3	992	S3	04-07	*	MSW 211	RAC		320	MST 247	RAC	245
	996 R	H2	01	*	MSW 211	RAC		320			
	996 S	H1	01	*	MSW 211	RAC		320			

	* 2 Scheiben erforderlich – 2 discs required		linke Seite – left side
	starre Scheibenausführung – fixed disc		rechte Seite – right side



Option 1

Option 2



Option 1

Option 2



Ducati											
ST4	996 S	S2	01-05	*	MSW 211	RAC		320	MST 247	RAC	245
	996 SPS, Biposto	H2	99-01	*	MSW 211	RAC		320			
S4R	996 Monster	M4	03-06	*	MSW 211	RAC		320	MST 377 RAC		245
	998 Biposto	916	02-03	*	MSW 211	RAC		320			
	998 S	H2	02-03	*	MSW 211	RAC		320			
	999 Biposto	H4	02-07	*	MSW 267 RAC			305	MST 419 RAC		240
	999	H4	02-06	*	MSW 267 RAC			320	MST 419 RAC		240
	999 R	H4	02-06	*	MSW 267 RAC			320	MST 419 RAC		240
	999 S	H4	02-06	*	MSW 267 RAC			320	MST 419 RAC		240
M	1000 Monster i.e., S i.e., Dark	M4	03-06	*	MSW 211	RAC		320	MST 247	RAC	245
S2R	1000 Monster	M4	06-08	*	MSW 211	RAC		320	MST 377 RAC		245
S4R	1000 Monster	M4	07-08	*	MSW 267 RAC			320	MST 377 RAC		245
S4RS	1000 Monster	M4	06-08	*	MSW 267 RAC			320	MST 377 RAC		245
	1000 S Sportclassic	C1	07-09	*	MSW 211	RAC		320	MST 247	RAC	245
	1000 Sportclassic	C1	06-08	*	MSW 211	RAC		320	MST 247	RAC	245
	1000 SS	V5	03-06	*	MSW 211	RAC		320	MST 247	RAC	245
GT	1000	C1	06-	*	MSW 211	RAC		320	MST 247	RAC	245
GT	1000 Touring	C1	06-	*	MSW 211	RAC		320	MST 247	RAC	245
	1098	H7	07-09	*	MSW 280 RAC			330	MST 461 RAC		245
	1098 R	H7	07-09	*	MSW 280 RAC			330	MST 461 RAC		245
	1098 S	H7	07-09	*	MSW 280 RAC			330	MST 461 RAC		245
	1100 Hypermotard, S/SP	B1	07-12	*	MSW 281 RAC			305	MST 377 RAC		245
	1100 Monster	M5	09-10	*	MSW 285 RAC			320	MST 420 RAC		245
	1100 Monster ABS	M5	09-10	*	MSW 285 RAC			320	MST 420 RAC		245
	1100 Monster S, S ABS	M5	09-10	*	MSW 267 RAC			320	MST 420 RAC		245
	1100 Monster Evo ABS	M5	11-	*	MSW 285 RAC			320	MST 420 RAC		245
	1100 Multistrada		03-09	*	MSW 281 RAC			305	MST 377 RAC		245
	1100 Streetfighter, S	F1	10-	*	MSW 280 RAC			330	MST 461 RAC		245
	1100 Streetfighter, S, ABS	F1	11-	*	MSW 280 RAC			330	MST 461 RAC		245
	1198	H7	09-11	*	MSW 280 RAC			330	MST 461 RAC		245
	1198 R	H7	10-	*	MSW 280 RAC			330	MST 461 RAC		245
	1198 S	H7	10-	*	MSW 280 RAC			330	MST 461 RAC		245
	1198 SP	H7	10-	*	MSW 280 RAC			330	MST 461 RAC		245
	1198 R, S, SP	H7	10-	Racing only	MSW 280 SP	RAC-SP		330	MST 461 RAC		245
	1198 Diavel		12-	*	MSW 285 RAC			320			
	1198 Diavel ABS		12-	*	MSW 285 RAC			320			
	1199 Panigale R		13-	*	MSW 280 RAC			330	MST 287 RAC		245
	1199 Panigale R		13-	Racing only	MSW 280 SP	RAC-SP		330	MST 287 RAC		245
	1199 Panigale, S, ABS		12-	*	MSW 280 RAC			330	MST 287 RAC		245
	1199 Panigale, S, ABS		12-	Racing only	MSW 280 SP	RAC-SP		330	MST 287 RAC		245
	1200 Monster, ABS		14-	*	MSW 267 RAC			320	MST 287 RAC		245
	1200 Monster S, ABS		14-	*	MSW 280 RAC			330	MST 287 RAC		245
	1200 Multistrada	A2	10-	*	MSW 285 RAC			320	MST 461 RAC		245
	1200 Multistrada ABS	A2	10-	*	MSW 285 RAC			320	MST 287 RAC		245
	1299 Panigale, ABS		15-	*	MSW 280 RAC			330	MST 287 RAC		245
	1299 Panigale, ABS		15-	Racing only	MSW 280 SP	RAC-SP		330	MST 287 RAC		245
Fantic											
	50 Big wheels		93-94		MST 250			155			
	50 Pony		93-95		MST 250			155			
	50 Grinta		95-		MST 250			155			
	50 Queenie		95-		MST 250			155			
Garelli											
	50 Big wheels		91-94		MST 250			155			
	50 Pony SR		92-95		MST 250			155			
	50 Big-Racing		94-		MST 250			155			
	50 Grinta		95		MST 250			155			
	50 Queenie		95-		MST 250			155			
Gas Gas											
	80 MC		95-02		MST 303			260			
EC	125	VTREC125...	95-		MST 303			260			
MC	125		95-		MST 303			260			
EC	200	VTREC200...	99-		MST 303			260			
MC	200	VTREC200...	99-		MST 303			260			
EC	250	VTREC250...	95-		MST 303			260			



Option 1

Option 2



Option 1

Option 2

**Gas Gas**

MC	250	VTREC250...	95-		MST 303		260			
EC	300	VTREC300...	99-		MST 303		260			
MC	300	VTREC300...	99-		MST 303		260			
EC	400 FSE	FS	02-					MST 266	RAC	220
EC	400 4-T	VTREC400...	02-03		MST 303		260			
MC	400 4-T	VTREC400...	02-03		MST 303		260			
EC	450 4-T	FS	03-		MST 303		260			
MC	450 4-T	FS	03-		MST 303		260			
EC	515 4-T		08-10		MST 303		260			
MC	515 4-T		08-10		MST 303		260			

Generic

	50 Explorer Cracker	B05	09-		MST 243	RAC	190			
	50 Ideo	B93	05-		MST 243	RAC	190			
	50 Sirion		12-		MST 243	RAC	190			
	50 Trigger	D01	02-		MST 243	RAC	190			
	50 XOR	BNOT	05-		MST 243	RAC	190			
GT	50 Race Explorer		09		MST 256		180			
	125 Sirion	T58	12-		MST 243	RAC	190			
	125 XOR	TEJ5	05-		MST 243	RAC	190			
GRS	600		13-		MSW 211		320			

Gilera

	50 DNA	C27	01-05					MST 260	RAC	200
	50 Easy Moving		95-96		MST 250		155			
	50 Ice	C30	01-03		MST 260	RAC	200			
	50 Storm	TEC	94-95		MST 236	RAC	190			
	50 Stalker	C13	97-03		MST 236	RAC	190	MST 255		174
	50 Stalker	C40	04-06		MST 236	RAC	190	MST 255		174
FX	50 Runner, Runner SP	C14	97-01		MST 254		220	MST 255		174
FX	50 Runner SP, PJ	C36	02-04		MST 254		220	MST 255		174
FX	50 Runner SP, PJ	C46	05-11		MST 396		220	MST 255		174
FX	50 Runner SP		12-		MST 396		220	MST 255		174
NRG	50	C18	94-		MST 236	RAC	190			
TPH	50 Typhoon	TEC	93-96		MST 236	RAC	190			
	125 Coguar	M17	99-02		MST 393		260			
	125 Nexus	M35	07-08		MST 393		260	MST 395		240
	125 Nexus i.e.	M35	09-		MST 393		260	MST 395		240
FX	125 Runner	M07	97-03		MST 254		220	MST 236	RAC	190
FXR	125 Runner SP	M07	00-03		MST 254		220			
TPH	125 Typhoon	M02	96-		MST 236	RAC	190			
VX	125 Runner	M24	01-04		MST 254		220	MST 260	RAC	200
VX	125 Runner, ST	M46	05-		MST 394		240	MST 396		220
VXR	125 Runner	M24	01-04		MST 254		220	MST 260	RAC	200
FXR	180 Runner	M08	97-02		MST 254		220	MST 236	RAC	190
FXR	180 Runner SP	M08	99-03		MST 254		220			
VXR	180 Runner	M08	01-04		MST 254		220	MST 260	RAC	200
VXR	200 Runner	M24	02-04		MST 254		220	MST 396		220
VXR	200 Runner, ST	M46	05-12		MST 394		240	MST 396		220
	250 Nexus	M35	06-08		MST 393		260	MST 395		240
	300 Nexus, ie	M35	08-		MST 393		260	MST 395		240
	500 Nexus	M35	03-	*	MST 393		260	MST 395		240
	500 Nexus SP	M35	06-07	*	MST 393		260	MST 395		240
RC	500 Fuoco i.e.	M61	07-	*	MST 394		240	MST 395		240
GP	800	M55	08-	*	MST 458		300	MST 459		280

Harley Davidson

XL	883 C Sportster Custom	XL1	99-02		MST 500	SWL	292	MST 501	SWL	292
XL	883 C Sportster Custom	XL2	03-10		MST 500	SWL	292	MST 501	SWL	292
XL	883 L Sportster Low	XL2	07-10		MST 500	SWL	292	MST 501	SWL	292
XL	883 L Sportster Super Low	XL2	11-13		MST 500	SWL	292	MST 503	SWL	260
XL	883 N Sportster Iron	XL2	09-10		MST 500	SWL	292	MST 501	SWL	292
XL	883 N Sportster Iron	XL2	11-13		MST 500	SWL	292	MST 503	SWL	260
XL	883 R Roadster	XL2	10-13	☐	MST 500	SWL	292	MST 503	SWL	260



* 2 Scheiben erforderlich – 2 discs required
 EX starre Scheibenausführung – fixed disc

☐ linke Seite – left side
 ☐ rechte Seite – right side



Option 1

Option 2



Option 1

Option 2



Harley Davidson

XL	883 R Roadster	XL2	10-13	▣	MST 500	SWR	292			
XL	883 R Sportster	XL1	02-03	▣	MST 500	SWL	292	MST 501	SWL	292
XL	883 R Sportster	XL1	02-03	▣	MST 500	SWR	292			
XLH	883 Sportster	XL1	00-03		MST 500	SWL	292	MST 501	SWL	292
XLH	883 Sportster	XL2	99-02		MST 500	SWL	292	MST 501	SWL	292
XLH	883 Sportster Hugger	XL1	00-03		MST 500	SWL	292	MST 501	SWL	292
XL	1200 C Sportster Custom	XL2	03-10		MST 500	SWL	292	MST 501	SWL	292
XL	1200 C Sportster Custom	XL2	11-		MST 500	SWL	292	MST 503	SWL	260
XL	1200 L Sportster Low	XL2	07-10		MST 500	SWL	292	MST 503	SWL	260
XL	1200 N Nightster	XL2	07-12		MST 500	SWL	292	MST 501	SWL	292
XL	1200 N Nightster	XL2	11-12		MST 500	SWL	292	MST 503	SWL	260
XL	1200 R Sportster Roadster	XL2	04-08	▣	MST 500	SWL	292	MST 501	SWL	292
XL	1200 R Sportster Roadster	XL2	04-08	▣	MST 500	SWR	292			
XL	1200 S Sportster Sport	XL1	99-02	▣	MST 500	SWL	292	MST 501	SWL	292
XL	1200 S Sportster Sport	XL1	99-02	▣	MST 500	SWR	292			
XL	1200 X Forty-Eight	XL2	10-13		MST 500	SWL	292	MST 501	SWL	292
XL	1200 X Forty-Eight	XL2	14-					MST 503	SWL	260
XR	1200		08-10					MST 503	SWL	260
XR	1200 X		10-12					MST 503	SWL	260
FLSTC	1340 Heritage Softail Classic	FS2	99-02		MST 500	SWL	292	MST 501	SWR	292
FLHR	1450 Road King	FL1	99-03	▣	MST 500	SWL	292	MST 501	SWR	292
FLHR	1450 Road King	FL1	99-03	▣	MST 500	SWR	292			
FLHRI	1450 Road King	FL1	04-06	▣	MST 500	SWL	292	MST 501	SWR	292
FLHRI	1450 Road King	FL1	04-06	▣	MST 500	SWR	292			
FLHRCI	1450 Road King Classic	FL1	99-06	▣	MST 500	SWL	292	MST 501	SWR	292
FLHRCI	1450 Road King Classic	FL1	99-06	▣	MST 500	SWR	292			
FLHRSI	1450 Road King Custom	FL1	99-07	▣	MST 500	SWL	292	MST 501	SWR	292
FLHRSI	1450 Road King Custom	FL1	99-07	▣	MST 500	SWR	292			
FLHT	1450 Electra Glide Standard	FL1	99-03	▣	MST 500	SWL	292	MST 501	SWR	292
FLHT	1450 Electra Glide Standard	FL1	99-03	▣	MST 500	SWR	292			
FLHTI	1450 Electra Glide Standard	FL1	04-06	▣	MST 500	SWL	292	MST 501	SWR	292
FLHTI	1450 Electra Glide Standard	FL1	04-06	▣	MST 500	SWR	292			
FLHTCUI	1450 Electra Glide Ultra Classic	FL1	99-07	▣	MST 500	SWL	292	MST 501	SWR	292
FLHTCUI	1450 Electra Glide Ultra Classic	FL1	99-07	▣	MST 500	SWR	292			
FLSTC	1450 Heritage Softail Classic	FS2	00-03		MST 500	SWL	292	MST 501	SWR	292
FLSTCI	1450 Heritage Softail Classic	FS2	01-06		MST 500	SWL	292	MST 501	SWR	292
FLSTF	1450 Fat Boy	FS2	00-03		MST 500	SWL	292	MST 501	SWR	292
FLSTFI	1450 Fat Boy	FS2	01-06		MST 500	SWL	292	MST 501	SWR	292
FLSTS	1450 Heritage Springer	FS2	99-03		MST 500	SWL	292	MST 501	SWR	292
FLTRI	1450 Road Glide Classic	FL1	99-07	▣	MST 500	SWL	292	MST 501	SWR	292
FLTRI	1450 Road Glide Classic	FL1	99-07	▣	MST 500	SWR	292			
FXD	1450 Super Glide	FL1	00-03		MST 500	SWL	292	MST 501	SWR	292
FXD	1450 Dyna Super Glide	FD1	99-03		MST 500	SWL	292	MST 501	SWR	292
FXDI	1450 Dyna Super Glide	FD1	04		MST 500	SWL	292	MST 501	SWR	292
FXDI	1450 Super Glide Anniversary	FD2	04-07		MST 500	SWL	292	MST 501	SWR	292
FXDCI	1450 Dyna Super Glide Custom	FD2	05-06		MST 500	SWL	292	MST 501	SWR	292
FXDL	1450 Dyna Low Rider	FD1	99-03	▣	MST 500	SWL	292	MST 501	SWR	292
FXDL	1450 Dyna Low Rider	FD1	99-03	▣	MST 500	SWR	292			
FXDLI	1450 Dyna Low Rider	FD2	04-06	▣	MST 500	SWL	292	MST 501	SWR	292
FXDLI	1450 Dyna Low Rider	FD2	04-06	▣	MST 500	SWR	292			
FXDS	1450 Dyna Convertible	FD1	99-02	▣	MST 500	SWL	292	MST 501	SWR	292
FXDS	1450 Dyna Convertible	FD1	99-02	▣	MST 500	SWR	292			
FXDWG	1450 Dyna Wide Glide	FD1	99-03		MST 500	SWL	292	MST 501	SWR	292
FXDX	1450 Dyna Super Glide Sport	FD1	99-03	▣	MST 500	SWL	292	MST 501	SWR	292
FXDX	1450 Dyna Super Glide Sport	FD1	99-03	▣	MST 500	SWR	292			
FXDXI	1450 Dyna Super Glide Sport	FD1	04-05	▣	MST 500	SWL	292	MST 501	SWR	292
FXDXI	1450 Dyna Super Glide Sport	FD1	04-05	▣	MST 500	SWR	292			
FXDXT	1450 Dyna Super Glide Tour Sport	FD1	01-03	▣	MST 500	SWL	292	MST 501	SWR	292
FXDXT	1450 Dyna Super Glide Tour Sport	FD1	01-03	▣	MST 500	SWR	292			
FXST	1450 Softtail Standard	FS2	00-03		MST 500	SWL	292	MST 501	SWR	292
FXSTB	1450 Night Train	FS2	00-04		MST 500	SWL	292	MST 501	SWR	292
FXSTBI	1450 Night Train	FS2	04-06		MST 500	SWL	292	MST 501	SWR	292
FXSTD	1450 Softtail Deuce	FS2	00-03		MST 500	SWL	292	MST 501	SWR	292
FXSTDI	1450 Softtail Deuce	FS2	01-04		MST 500	SWL	292	MST 501	SWR	292
FLHR	1584 Road King	FL2	07	▣	MST 500	SWL	292	MST 501	SWR	292
FLHR	1584 Road King	FL2	07	▣	MST 500	SWR	292			
FLHRC	1584 Road King Classic	FL2	07	▣	MST 500	SWL	292	MST 501	SWR	292



Option 1

Option 2



Option 1

Option 2

**Harley Davidson**

FLHRC	1584 Road King Classic	FL2	07		☑	MST 500	SWR	292			
FLHT	1584 Electra Glide Standard	FL1	07		☑	MST 500	SWL	292	MST 501	SWR	292
FLHT	1584 Electra Glide Standard	FL1	07		☑	MST 500	SWR	292			
FLHTCU	1584 Ultra Classic Electra Glide	FL1	07		☑	MST 500	SWL	292	MST 501	SWR	292
FLHTCU	1584 Ultra Classic Electra Glide	FL1	07		☑	MST 500	SWR	292			
FLHX	1584 Street Glide	FL1	06-07		☑	MST 500	SWL	292	MST 501	SWR	292
FLHX	1584 Street Glide	FL1	06-07		☑	MST 500	SWR	292			
FLSTC	1584 Heritage Softail Classic	FS2	07-11			MST 500	SWL	292	MST 501	SWR	292
FLSTF	1584 Fat Boy	FS2	07-11			MST 500	SWL	292	MST 501	SWR	292
FLSTFB	1584 Fat Boy Special	FS2	07-11			MST 500	SWL	292	MST 501	SWR	292
FLSTN	1584 Softail Deluxe	FS2	07-11			MST 500	SWL	292	MST 501	SWR	292
FLSTSB	1584 Cross Bones	FS2	08-11			MST 500	SWL	292	MST 501	SWR	292
FXCW	1584 Softail Rocker	FS2	08-09			MST 500	SWL	292	MST 501	SWR	292
FXCWC	1584 Softail Rocker C	FS2	08-11			MST 500	SWL	292	MST 501	SWR	292
FXS	1584 Softail Black Line	FS2	11-			MST 500	SWL	292	MST 501	SWR	292
FXSTB	1584 Night Train	FS2	07-09			MST 500	SWL	292	MST 501	SWR	292
FXSTBIC	1584 Night Creeper	FS2	07-08			MST 500	SWL	292	MST 501	SWR	292
FXSTC	1584 Softail Custom	FS2	07-09			MST 500	SWL	292	MST 501	SWR	292
FLS	1690 Softail Slim, ABS	FS2	12-			MST 500	SWL	292	MST 501	SWR	292
FLSTC	1690 Heritage Softail Classic	FS2	12-			MST 500	SWL	292	MST 501	SWR	292
FLSTF	1690 Softail Fat Boy	FS2	12-			MST 500	SWL	292	MST 501	SWR	292
FLSTFB	1690 Softail Fat Boy Special	FS2	12-			MST 500	SWL	292	MST 501	SWR	292
FLSTN	1690 Softail Deluxe, ABS	FS2	12-			MST 500	SWL	292	MST 501	SWR	292

Honda

GP	50 Scooter		90-			MST 241		162			
HSC	50 ZR	AF37	92-			MST 241		162			
HSC	50 1	AF37	93-			MST 241		162			
MTX	50 S	AD04	83-87			MST 300		240			
NSC	50 C Vision	AF72	11-	14"		MST 452		190			
NSC	50 AC Vision	AF72	11-	16"		MST 452		190			
SFX	50 Sport	AF37	95-04			MST 241		160			
SXR	50	AF18	98-99			MST 241		160			
SGX	50 sky	AF43	97-03			MST 243	RAC	190			
SJ	50 Bali	AF32	93-99			MST 243	RAC	190	MST 252	RAC	190
SK	50 Dio	AF18	90-			MST 241		162			
ZX	50 ZX	SC01	94-			MST 241		162			
	50 Yupi		90-			MST 243	RAC	190			
CR	80 R	HE02	92-95						MST 324	EC	190
CR	80 R	HE04	96-02			MST 302	EC	220	MST 324	EC	190
MTX	80 C	HD06	82-			MST 300		240			
CR	85 R	HE07	03-07			MST 302	EC	220	MST 324	EC	190
SJ	100 Bali	HF07	95-99			MST 243	RAC	190	MST 252	RAC	190
NSC	110 C Vision	JF31	11-	14"		MST 452		190			
NSC	110 AC Vision	JF31	11-	16"		MST 452		190			
SCV	110 Lead	JF11	08-09			MST 243	RAC	190			
SCV	110 Lead	JF19	10-13			MST 452		190			
CH	125 Spacy	JF03	98-			MST 243	RAC	190			
CBF	125	JC40	09-			MST 273 RAC		240			
CBR	125 R	JC34	04-07			MST 205		276	MST 245	RAC	220
CBR	125 R	JC39	08-10			MST 205		276	MST 245	RAC	220
CBR	125 R	JC50	11-			MST 275 RAC		276	MST 245	RAC	220
CR	125 R	JE01	89-91						MST 321		220
CR	125 R	JE01	92-94			MST 300		240	MST 321		220
CR	125 R	JE01	95-97			MST 301	RAC	EC	240	MST 321	220
CR	125 R	JE01	98-01			MST 301	RAC	EC	240	MST 322	240
CR	125 R	JE01	02-03			MST 301	RAC	EC	240	MST 328	RAC EC 240
CR	125 R	JE01	04-			MST 301	RAC	EC	240	MST 328	RAC EC 240
FES	125 Pantheon	JF05	98-02			MST 453		240			
FES	125 Pantheon	JF12	03-06			MST 453		240	MST 245	RAC	220
FES	125 S-Wing	JF12	07-			MST 453		240			
FES	125 S-Wing ABS	JF12	07-			MST 453		240			
MSX	125	JC61	13-			MST 269 RAC		220	MST 270 RAC		190
PCX	125	JF28	10-			MST 452		220			



* 2 Scheiben erforderlich – 2 discs required
 EX starre Scheibenausführung – fixed disc

☑ linke Seite – left side
 ☑ rechte Seite – right side



Option 1

Option 2



Option 1

Option 2



Honda										
RS	125 R	JF05	91-03		MSW 212	RAC		296		
SH	125	JF09	01-04		MST 453			240		
SH	125	JF14	05-08		MST 453			240		
SH	125 i	JF23	09-12		MST 453			240	MST 240	240
SH	125 A ABS	JF41	13-		MST 453			240	MST 240	240
XL	125 R	KF06			MST 300			240		
XLV	125 Varadero	JC32	01-		MST 424			276		
CRF	150 R	CRF150	07-		MST 302	EC		220	MST 324	EC 190
FES	150 Pantheon	JF05	98-02		MST 453			240	MST 453	240
FES	150 Pantheon	KF06	03-06		MST 453			240	MST 453	240
FES	150 S-Wing		07-		MST 453			240	MST 453	240
FES	150 S-Wing ABS		07-		MST 453			240	MST 453	240
PCX	150		13-		MST 452			220		
SH	150 i	KF08/KF10	05-		MST 453			240	MST 240	240
ATC	250 R	ATC250	85-88		MST 403			174		
CB	250 F Hornet	MC31	96-01		MSW 212	RAC		296	MST 245	RAC 220
CB	250 N	CB250N	82-88		MSW 212	RAC		296		
CB	250 Two Fifty	MC26	92-05		MST 240	RAC		240		
CBR	250 RA ABS	MC41	11-		MSW 272			296	MST 455	220
CBR	250 R	MC41	11-		MSW 272			296	MST 245	220
CR	250 R	ME03	89-91						MST 321	220
CR	250 R	ME03	92-94		MST 300			240	MST 321	220
CR	250 R	ME03	95-97		MST 301	RAC	EC	240	MST 321	220
CR	250 R	ME03	98-01		MST 301	RAC	EC	240	MST 322	240
CR	250 R	ME03	02-03		MST 301	RAC	EC	240	MST 328	RAC EC 240
CR	250 R	ME03	04-07		MST 301	RAC	EC	240	MST 328	RAC EC 240
CRF	250 L		12-		MST 454			256	MST 245	RAC 240
CRF	250 R	ME11	04-14		MST 301	RAC	EC	240	MST 328	RAC EC 240
CRF	250 R		15-		MST 281 EC			260	MST 328 EC	240
CRF	250 X		04-		MST 301	RAC	EC	240	MST 328	RAC EC 240
FES	250 Foresight	MF04	98-99		MST 453			240		
FES	250 Foresight	MF05	01-05		MST 453			240	MST 245	220
NSS	250 Forza	MF06	00-04		MST 453			240	MST 245	220
NSS	250 Forza ABS	HF08	05-06		MST 453			240	MST 240	240
NSS	250 Jazz	MF07	00-04		MST 453			240		
PS	250 Ruckus	MF09	05-06		MST 453			240		
RS	250 R		90-97	*	MSW 212	RAC		296		
TRX	250 X	TE13	87-92		MST 403			174		
TRX	250 EX	TRX250	01-08		MST 403			174		
TSR	250	TSR250	99-00		MSW 212	RAC		296		
VTR	250 F	MC15	98-						MST 245	RAC 220
XL	250 R	MD11	84-93		MST 300			240		
XL	250 R Baja	MD11	88-91		MST 300			240	MST 326	220
XR	250 RB	ME01	84-90		MST 300			240		
XR	250	ME06	91-03		MST 300			240	MST 323	220
CBR	300 F		14-		MSW 272			296	MST 455	220
CBR	300 R		15-		MSW 272			296	MST 455	220
SH	300 i	NF02	07-		MST 450			256	MST 373	RAC 256
SH	300 i ABS	NF02	07-		MST 450			256	MST 373	RAC 256
TRX	300 EX Sporttrax	TE19	93-		MST 403			174	MST 404	220
CB	350 S-G	NC22	87-	SE market	MST 201			256		
XL	350 R	ND03	84-90		MST 300			240		
XR	350 RF	NE02			MST 300			240		
XR	350 RD	NE01	84-87		MST 300			240		
CB	400	NC27	89-91						MST 245	RAC 220
CBR	400 F-F2	NC23	85-87		MSW 212	RAC		296		
FJS	400 Silver Wing	NF01	06-08		MST 373	RAC		256		
RVF	400 RR	NC35	94-96	*	MSW 212	RAC		296		
TRX	400 EX Sporttrax	TE23	99-		MST 403			174	MST 323	220
VFR	400 R	NC24	87-88	*	MST 205			276		
VFR	400 R	NC30	89-93	*	MSW 212	RAC		296		
XR	400 R	NE03	96-03		MST 300			240	MST 323	220
CB	450 S	PC17	86-88	*	MST 201			256		
CRF	450 R	PE05	02-14		MST 301	RAC	EC	240	MST 328	RAC EC 240
CRF	450 R		15-		MST 281 EC			260	MST 328 EC	240
CRF	450 X	PE05	05-		MST 301	RAC	EC	240	MST 328	RAC EC 240
TRX	450 R, ER	TE22	04-		MST 403			174		



Option 1

Option 2



Option 1

Option 2



Honda

CB	500	PC26	94-96		MST 206	RAC	296			
CB	500	PC32	97-03		MST 206	RAC	296	MST 240	RAC	240
CB	500 F	PC45	13-		MST 465 RAC		320	MST 338	RAC	240
CB	500 FA ABS	PC45	13-		MST 465 RAC		320	MST 338	RAC	240
CB	500 X	PC46	13-		MST 465 RAC		320	MST 338	RAC	240
CB	500 XA ABS	PC46	13-		MST 465 RAC		320	MST 338	RAC	240
CBF	500	PC39	04-07		MST 206	RAC	296	MST 338	RAC	240
CBF	500 A ABS	PC39	04-07		MST 206	RAC	296	MST 338	RAC	240
CBR	500 R	PC44	13-		MST 465 RAC		320	MST 338	RAC	240
CBR	500 RA ABS	PC44	13-		MST 465 RAC		320	MST 338	RAC	240
CR	500 RE	PE02	89-91					MST 321		220
CR	500 RE	PE02	92-94		MST 300		240	MST 321		220
CR	500 RE	PE02	95-01		MST 301	RAC	EC	240	MST 321	220
GB	500 Clubmann	PC16	88-		MST 202		276			
NX	500 Dominator	RD02	88-91	AU market	MST 201		256	MST 323		220
NX	500 Dominator	RD02	92-97	AU market	MST 201		256	MST 326		220
NX	500 Dominator	RD08	98-03	AU market	MST 201		256	MST 326		220
XBR	500 S	PC15	85-89		MST 202		276			
XR	500 R	PE03	83-86		MST 300		240			
CB	600 F Hornet	PC34	98-99					MST 245	RAC	SL 220
CB	600 F Hornet	PC34	00-01		* MSW 243		296	MST 245	RAC	SL 220
CB	600 F Hornet	PC36	02-06		* MSW 243		296	MST 245	RAC	SL 220
CB	600 F Hornet	PC41	07-		* MSW 283 RAC		296	MST 338	RAC	240
CB	600 FA Hornet ABS	PC41	07-		* MSW 283 RAC		296	MST 338	RAC	240
CB	600 S Hornet	PC34	00-01		* MSW 243		296	MST 245	RAC	SL 220
CB	600 S Hornet	PC36	02-06		* MSW 243		296	MST 245	RAC	SL 220
CBF	600 N, S	PC38	04-07		* MST 206	RAC	296	MST 338	RAC	240
CBF	600 NA ABS, SA ABS	PC38	04-07		* MSW 272		296	MST 338	RAC	240
CBF	600 N, S	PC43	08-		* MSW 272		296	MST 338	RAC	240
CBF	600 NA ABS, SA ABS	PC43	08-		* MSW 272		296	MST 338	RAC	240
CBR	600 F	PC19	87-88		* MST 205		276			
CBR	600 F	PC23	89-90		* MST 205		276			
CBR	600 F	PC25	91-94		* MST 205		276	MST 245	RAC	SL 220
CBR	600 F	PC31	95-98		* MSW 212	RAC	296	MST 245	RAC	SL 220
CBR	600 F	PC35	99-00		* MSW 236		296	MST 245	RAC	SL 220
CBR	600 F	PC35	01-07		* MSW 244	RAC	296	MST 245	RAC	SL 220
CBR	600 F ABS	PC40	11-		* MSW 283 RAC		296	MST 338	RAC	240
CBR	600 FA ABS	PC40	11-		* MSW 283 RAC		296	MST 338	RAC	240
CBR	600 RR	PC37	03-06		* MSW 240	RAC	310	MST 245	RAC	SL 220
CBR	600 RR	PC40	07-		* MSW 240	RAC	310	MST 245	RAC	SL 220
CBR	600 RR	PC40	07-	Racing only	* MSW 240 SP	RAC-SP	310	MST 245	RAC	SL 220
CBR	600 RA ABS	PC40	09-		* MSW 240	RAC	310	MST 425 RAC		220
FJS	600 Silver Wing	PF01	01-06		MST 373	RAC	256	MST 240	RAC	240
VT	600 C	PC21	88-93		MST 203		296			
VT	600 C	PC21	94-		MST 203		296			
XL	600	PD03	83-87		MST 300		240			
XL	600 V Transalp	PD06	87-90		MST 202		276			
XL	600 V Transalp	PD06	91-96		MST 202		276	MST 240	RAC	240
XL	600 V Transalp	PD10	97-99		* MST 201		256	MST 240	RAC	240
XR	600 R	PE04	87-90		MST 300		240			
XR	600 R	PE04	91-99		MST 300		240	MST 323		220
CB	650 F		14-		MST 465 RAC		320	MST 338	RAC	240
CBR	650 F		14-		MST 465 RAC		320	MST 338	RAC	240
FX	650 Vigor	RD09	99-02		MST 205		276	MST 326		220
NT	650 Hawk	RC31	88-90		MST 207		318			
NTV	650 Revere	RC33	88-97		MST 207		318			
NT	650 V Deauville	RC47	98-05		* MST 206	RAC	296	MST 202		276
NX	650 Dominator	RD02	88-91		MST 201		256	MST 323		220
NX	650 Dominator	RD02	92-97		MST 201		256	MST 326		220
NX	650 Dominator	RD08	98-03		MST 201		256	MST 326		220
SLR	650	RD09	97-		MST 202		276	MST 326		220
XL	650 V Transalp	RD10	00-01		* MST 201		256	MST 240	RAC	240
XL	650 V Transalp	RD11	02-07		* MST 201		256	MST 240	RAC	240
XR	650 R	RE01	00-07		MST 300		240			



* 2 Scheiben erforderlich – 2 discs required
 EX starre Scheibenausführung – fixed disc

☑ linke Seite – left side
 ☑ rechte Seite – right side



Option 1

Option 2



Option 1

Option 2



Honda											
XR	650 L	RD06	93-99		MST 201			256	MST 245	RAC	220
XRV	650 Africa Twin	RD03	88-90		MST 206 RAC				MST 240	RAC	240
CTX	700 D	RC68	14-		MST 447 RAC			320	MST 446 RAC		240
CTX	700 DA ABS, DCT	RC68	14-		MST 447 RAC			320	MST 446 RAC		240
CTX	700 N	RC68	14-		MST 447 RAC			320	MST 446 RAC		240
CTX	700 NA ABS, ND-DCT	RC68	14-		MST 447 RAC			320	MST 446 RAC		240
NC	700 D Integra ABS, SD-DCT	RC62	12-13		MST 447 RAC			320	MST 446 RAC		240
NC	700 S	RC70	12-		MST 447 RAC			320	MST 446 RAC		240
NC	700 SA ABS, SD-DCT	RC70	12-		MST 447 RAC			320	MST 446 RAC		240
NC	700 X	RC72	12-		MST 447 RAC			320	MST 446 RAC		240
NC	700 XA ABS, XD-DCT	RC72	12-		MST 447 RAC			320	MST 446 RAC		240
NSA	700 DN-01 ABS	RC55	08-11	*	MSW 272			296			
VF	700 C	RC43	93-99		MST 207			318			
NT	700 V Deauville	RC52	06-09	*	MST 206	RAC		296	MST 202		276
NT	700 VA Deauville ABS	RC52	06-09	*	MST 206	RAC		296	MST 202		276
NT	700 V Deauville	RC59	10-	*	MST 206	RAC		296	MST 202		276
NT	700 VA Deauville ABS	RC59	10-	*	MST 206	RAC		296	MST 202		276
VF	700 S-C	RC21	84-85		MST 205			276			
XL	700 V Transalp	RD13	08-09	*	MST 201			256	MST 240	RAC	240
XL	700 VA Transalp ABS	RD13	08-09	*	MST 201			256	MST 240	RAC	240
XL	700 V Transalp	RD15	10-	*	MST 201			256	MST 240	RAC	240
XL	700 VA Transalp ABS	RD15	10-	*	MST 201			256	MST 240	RAC	240
CB	750 Seven Fifty	RC42	92-03	*	MST 206	RAC		296	MST 240	RAC	240
CBX	750 F	RC17	84-87	*	MST 205			276	MST 202		276
NC	750 D Integra ABS, SD-DCT	RC71	14-		MST 447 RAC			320	MST 446 RAC		240
NC	750 S	RC70	14-		MST 447 RAC			320	MST 446 RAC		240
NC	750 SA ABS, SD-DCT	RC70	14-		MST 447 RAC			320	MST 446 RAC		240
NC	750 X	RC72	14-		MST 447 RAC			320	MST 446 RAC		240
NC	750 XA ABS, XD-DCT	RC72	14-		MST 447 RAC			320	MST 446 RAC		240
NM4	750 Vultus ABS		14-		MST 447 RAC			320	MST 446 RAC		240
VF	750 C	RC43	93-99		MST 207			318			
VFR	750 F	RC24	86-87	*	MST 205			276			
VFR	750 F	RC24	88-89	*	MST 206	RAC		296			
VFR	750 F	RC36	90-93	*	MST 206	RAC		296	MST 398		256
VFR	750 F	RC36	94-97	*	MSW 212	RAC		296	MST 398		256
VT	750 C Shadow	RC44	97-03		MST 206	RAC		296			
VT	750 C Shadow	RC50	04-09		MST 206	RAC		296			
VT	750 CS Shadow	RC50	10-	ABS	MST 206	RAC		296			
VT	750 C Shadow Spirit	RC53	07-09		MST 206	RAC		296			
VT	750 C Shadow Black Spirit	RC53	10-12		MST 206	RAC		296			
VT	750 C Shadow ABS	RC53	10-		MST 206	RAC		296			
VT	750 D Black Widow	RC48	01-04		MST 206	RAC		296			
VT	750 S		11-		MST 206	RAC		296			
XLV	750 R	RD01	84-88		MST 205			276			
XRV	750 Africa Twin	RD04	90-92	*	MST 204			276	MST 325		256
XRV	750 Africa Twin	RD07	93-03	*	MST 204			276	MST 325		256
PC	800 Pacific Coast	RC34	89-98	*	MST 205			276			
VFR	800	RC46	98-05	*	MSW 236			296	MST 398		256
VFR	800	RC46	06-09	*	MSW 210			296	MST 398		256
VFR	800 ABS	RC46	02-	*	MSW 210			296			
VFR	800 X Crossrunner ABS	RC60	11-	*	MSW 210			296			
VFR	800 F		14-	*	MSW 240	RAC		310	MST 426		256
VFR	800 FA ABS		14-	*	MSW 240	RAC		310			
CB	900 F Hornet	SC48	02-06	*	MSW 244			296	MST 240	RAC	240
CBR	900 RR Fireblade	SC28	92-93	*	MSW 236			296	MST 245	RAC	SL 220
CBR	900 RR Fireblade	SC28	94-95	*	MSW 212	RAC		296	MST 245	RAC	SL 220
CBR	900 RR Fireblade	SC33	96-97	*	MSW 212	RAC		296	MST 245	RAC	SL 220
CBR	900 RR Fireblade	SC33	98-99	*	MSW 227			310	MST 245	RAC	SL 220
CBR	900 RR Fireblade	SC44	00-01	*	MSW 245	RAC		330	MST 245	RAC	SL 220
CBR	954 RR Fireblade	SC50	02-03	*	MSW 245	RAC		330	MST 245	RAC	SL 220
CB	1000 R	SC60	08-	*	MSW 240	RAC		310	MST 390 RAC		256
CB	1000 RA ABS	SC60	08-	*	MSW 240	RAC		310			256
CBF	1000	SC58	06-10	*	MSW 272			296	MST 338	RAC	240
CBF	1000 ABS	SC58	06-10	*	MSW 272			296	MST 338	RAC	240
CBF	1000 F	SC64	10-11	*	MSW 272			296	MST 338	RAC	240
CBF	1000 FA ABS	SC64	10-	*	MSW 272			296	MST 338	RAC	240



Honda													
CBR	1000 RR Fireblade	SC57	04-05		*	MSW 240	RAC		310	MST 245	RAC	SL	220
CBR	1000 RR Fireblade	SC57	06-07		*	MSW 254	RAC		320	MST 245	RAC	SL	220
CBR	1000 RR Fireblade	SC59	08-		*	MSW 265 RAC			320	MST 427 RAC			220
CBR	1000 RR Fireblade	SC59	08-	Racing only	*	MSW 265 SP	RAC-SP		320	MST 427 RAC			220
CBR	1000 RA Fireblade	SC59	09-		*	MSW 265 RAC			320	MST 427 RAC			220
CBR	1000 RA Fireblade	SC59	09-	Racing only	*	MSW 265 SP	RAC-SP		320	MST 427 RAC			220
CBR	1000 F	SC21	87-88		*	MST 206	RAC		296	MST 202			276
CBR	1000 F	SC24	89-92		*	MST 206	RAC		296				
CBR	1000 F	SC24	93-99		*	MST 206	RAC		296				
VF	1000 F, F2	SC15	84-87		*	MST 205			276				
VF	1000 R	SC16	84-87		*	MST 205			276				
VTR	1000 SP1	SC45	00-01		*	MSW 254	RAC		320	MST 245	RAC	SL	220
VTR	1000 SP2	SC45	02-		*	MSW 254	RAC		320	MST 245	RAC	SL	220
VTR	1000 Firestorm	SC36	97-		*	MSW 212	RAC		296	MST 245	RAC	SL	220
XL	1000 V Varadero	SD01	99-00		*	MSW 236			296	MST 325			256
XL	1000 V Varadero	SD02	01- 02		*	MSW 236			296	MST 325			256
XL	1000 V Varadero	SD02	03-10		*	MSW 236			296	MST 373	RAC		256
XL	1000 VA Varadero ABS	SD02	04-10		*	MSW 210			296	MST 373	RAC		256
XL	1000 VA Varadero ABS	SD03	11-		*	MSW 210			296	MST 373	RAC		256
CB	1100 A ABS	SC65	13-		*	MST 278			296	MST 274			256
CB	1100 EX, ABS	SC65	13-14	cast wheel	*	MST 278			296	MST 274			256
CB	1100 EX, ABS	SC65	13-	spoke wheel	*	MSW 210			296	MST 274			256
CB	1100 SFX-Eleven	SC42	00-01		*	MSW 258 RAC			310	MST 373	RAC		256
CBR	1100 XX Blackbird	SC35	99-08		*	MSW 258 RAC			310	MST 373	RAC		256
ST	1100 Pan European	SC26	90-02		*	MST 207			318				
ST	1100 A Pan European ABS	SC26	92-95		*	MST 207			318				
ST	1100 A Pan European ABS	SC26	96-02		*	MST 206	RAC		296				
VT	1100 C Shadow	SC23	92-94			MST 207			318				
VT	1100 C2	SC32	95-02			MST 207			318	MST 202			276
VFR	1200 FD ABS	SC63	10-		*	MSW 201			320	MST 448			276
VFR	1200 FA ABS	SC63	10-		*	MSW 201			320	MST 448			276
VFR	1200 XA Crosstourer ABS	SC70	12-		*	MST 449			310	MST 448			276
CB	1300 Superfour	SC54	05-09		*	MSW 240	RAC		310	MST 373	RAC		256
CB	1300 Superfour ABS	SC54	05-09		*	MSW 240	RAC		310	MST 373	RAC		256
CB	1300 S, SA	SC54	05-		*	MSW 240	RAC		310	MST 373	RAC		256
CTX	1300 A ABS	SC74	14-		*	MSW 284			310	MST 428			316
ST	1300 Pan European	SC51	02-		*	MSW 284			310	MST 428			316
ST	1300 A Pan European ABS	SC51	02-		*	MSW 284			310	MST 428			316
GL	1500 F6C Valkyrie	SC34	97-03		*	MSW 236			296				
GL	1800 Gold Wing	SC47	01-		*	MSW 236			296				
VTX	1800 C	SC46	01-08		*	MSW 244			296				

Husaberg													
TE	125		12-			MST 265	RAC	EC	260	MST 266	RAC	EC	220
TE	250		10-			MST 265	RAC	EC	260	MST 266	RAC	EC	220
FE	250		12-			MST 265	RAC	EC	260	MST 266	RAC	EC	220
TE	300		10-			MST 265	RAC	EC	260	MST 266	RAC	EC	220
FE	350		12-			MST 265	RAC	EC	260	MST 266	RAC	EC	220
FE	390		09-			MST 265	RAC	EC	260	MST 266	RAC	EC	220
FE	400	Husaberg FE	00-			MST 265	RAC	EC	260	MST 266	RAC	EC	220
FE	400 E	Husaberg FE	01-			MST 265	RAC	EC	260	MST 266	RAC	EC	220
FS	400 C	Husaberg FE	01-			MST 265	RAC	EC	260	MST 266	RAC	EC	220
FS	400 E	Husaberg FE	01-			MST 265	RAC	EC	260	MST 266	RAC	EC	220
FE	450		09-			MST 265	RAC	EC	260	MST 266	RAC	EC	220
FX	450		09-			MST 265	RAC	EC	260	MST 266	RAC	EC	220
FC	501 CR	YU7FC...	00-			MST 265	RAC	EC	260	MST 266	RAC	EC	220
FE	501	Husaberg FE	00-			MST 265	RAC	EC	260	MST 266	RAC	EC	220
FE	501 E	Husaberg FE	01-			MST 265	RAC	EC	260	MST 266	RAC	EC	220
FE	570		09-			MST 265	RAC	EC	260	MST 266	RAC	EC	220
FS	570		10-11							MST 266	RAC	EC	220
FC	600 CR	YU7FC...	00-			MST 265	RAC	EC	260	MST 266	RAC	EC	220
FE	600	Husaberg FE	00-			MST 265	RAC	EC	260	MST 266	RAC	EC	220
FE	600 SM	Husaberg FE	00-			MSW 114 RAC			320	MST 266	RAC	EC	220

	* 2 Scheiben erforderlich – 2 discs required		linke Seite – left side
	starre Scheibenausführung – fixed disc		rechte Seite – right side



Option 1

Option 2



Option 1

Option 2

**Husaberg**

FS	650 C	Husaberg FE	01-	MSW 114 RAC			320			
FS	650 E	Husaberg FE	01-	MSW 114 RAC			320			

Husqvarna

WRS	50	WRS	00-	MST 236	RAC		190			
CR	125	ZCG...	92-94	MST 319			260	MST 351		220
CR	125	ZCG...	95-99	MST 319			260	MST 351		220
CR	125	ZCG...	00-05	MST 320	EC		260	MST 353		220
CR	125		06-10	MST 320	EC		260	MST 399		240
CR	125		11-13	MST 320 EC			260	MST 440 EC		240
SM	125 S	ZCG...	01-10	MST 320	EC		260	MST 353		220
TC	125		14-	MST 265	RAC	EC	260	MST 266	RAC	EC 220
TE	125		14-	MST 265	RAC	EC	260	MST 266	RAC	EC 220
TE	125		11-12	MST 320 EC	EC		260	MST 353		240
WR	125	ZCG...	92-94	MST 319			260	MST 351		220
WR	125	ZCG...	95-99	MST 319			260	MST 351		220
WR	125	2H	00-05	MST 320	EC		260	MST 353		220
WR	125		06-10	MST 320	EC		260	MST 399		240
WR	125		11-13	MST 320 EC			260	MST 440 EC		240
WRE	125		02-10	MST 320	EC		260	MST 353		220
WRX	125		07-	MST 320	EC		260	MST 353		220
CR	250	ZCG...	92-99	MST 319			260	MST 351		240
CR	250	ZCG...	00-05	MST 320 EC			260	MST 353		240
FC	250		14-	MST 265	RAC	EC	260	MST 266	RAC	EC 220
FE	250		14-	MST 265	RAC	EC	260	MST 266	RAC	EC 220
TC	250	ZCG...	03-05	MST 320 EC			260	MST 353		240
TC	250		06-10	MST 320	EC		260	MST 399		240
TC	250		11-13	MST 320 EC			260	MST 440 EC		240
TC	250		14-	MST 265	RAC	EC	260	MST 266	RAC	EC 220
TE	250	H8	03-05	MST 320	EC		260	MST 353		240
TE	250		06-10	MST 320	EC		260	MST 399		240
TE	250		11-13	MST 320 EC			260	MST 440 EC		240
TE	250		14-	MST 265	RAC	EC	260	MST 266	RAC	EC 220
TXC	250	ZCG...	03-05	MST 320	EC		260	MST 353		220
TXC	250		06-10	MST 320	EC		260	MST 399		240
TXC	250		11-13	MST 320 EC			260	MST 440 EC		240
WR	250	ZCG...	92-99	MST 319			260	MST 351		220
WR	250	3H	00-13	MST 320 EC			260	MST 353		220
WR	300		09-13	MST 320 EC			260	MST 353		220
TE	300		14-	MST 265	RAC	EC	260	MST 266	RAC	EC 220
TE	310		09-10	MST 320	EC		260	MST 399		240
TE	310		11-13	MST 320 EC			260	MST 440 EC		240
FC	350		14-	MST 265	RAC	EC	260	MST 266	RAC	EC 220
FE	350		14-	MST 265	RAC	EC	260	MST 266	RAC	EC 220
TE	350	ZCG...	92-98	MST 319			260	MST 351		220
CR	360	ZCG...	92-94	MST 319			260	MST 351		220
WR	360	ZCG...	92-99	MST 319			260	MST 351		220
WR	360	3H	00-02	MST 320	EC		260	MST 353		220
TE	400	H8	01-02	MST 320	EC		260	MST 353		220
TE	410	ZCG...	95-99	MST 319			260	MST 351		220
TE	410	ZCG...	00	MST 320	EC		260	MST 353		220
TE	449		11-	MST 320	EC		260	MST 440 EC		240
FC	450		14-	MST 265	RAC	EC	260	MST 266	RAC	EC 220
FE	450		14-	MST 265	RAC	EC	260	MST 266	RAC	EC 220
TC	450	ZCG...	03-04	MST 320	EC		260	MST 353		220
TC	450		05-10	MST 320	EC		260	MST 399		240
TE	450	ZCG...	03-04	MST 320	EC		260	MST 353		220
TE	450	H8	05-10	MST 320	EC		260	MST 399		240
TXC	450		05-10	MST 320	EC		260	MST 399		240
FE	501		14-	MST 265	RAC	EC	260	MST 266	RAC	EC 220
TE	510		04-05	MST 320	EC		260	MST 353		220
TE	510		06-10	MST 320	EC		260	MST 399		240
TXC	510		04-05	MST 320	EC		260	MST 353		220
TXC	510		06-10	MST 320	EC		260	MST 399		240
TC	510		04-05	MST 320	EC		260	MST 353		220
TC	510		06-10	MST 320	EC		260	MST 399		240



Husqvarna										
TE	511		11-13	MST 320 EC		260	MST 440 EC			240
TXC	511		11-13	MST 320 EC		260	MST 440 EC			240
TE	570	H8	01-03	MST 320	EC	260	MST 351			220
TC	610	ZCG...	92-99	MST 319		260	MST 351			220
TC	610	H6	00	MST 320	EC	260	MST 351			220
TE	610 E	H7	98-01	MST 319		260	MST 351			220
TE	610 E	H7	02-04	MST 320 EC		260	MST 353			220
TE	610 E i.e.	A1	05-10	MST 320 EC		260	MST 440 EC			240
TE	610		92-99	MST 319		260	MST 351			220
TE	610	H6	00	MST 320	EC	260	MST 353			220
TE	630		10-13	MST 320 EC		260	MST 440 EC			240
TR	650 Strada, Terra		12-	MST 337	RAC	300	MST 330			240
	900 Nuda, R		12-				MST 372	RAC		265
Hyosung										
CAB	50	SB	95-	MST 250		155				
GV	650	GV650	04-	MSW 224	RAC	298				
GV	700	GVC	06-	MSW 224	RAC	298				
Italjet										
	50 Pista 2		92-97	MST 250		155				
	50 Bazooka 2		92-97	MST 250		155				
	50 Yankee		94-97	MST 250		155				
Kawasaki										
KX	65	KX65.	01-	MST 443 EC			MST 443 EC			180
KX	80	KX80N	88-00				MST 332			184
KX	85	KX85.	01-	MST 441 EC		220	MST 442 EC			184
KX	100	KX100N	88-05				MST 332			184
KX	100	KX100N	06-	MST 441 EC		220	MST 442 EC			184
KX	125	KX125K	89-02	MST 306		250	MST 333			220
KX	125	KX125M	03-05	MST 307	RAC	250	MST 339	RAC	EC	240
KX	125	KX125	06-08	MST 308 RAC	EC	250	MST 339	RAC	EC	240
KDX	200	KDX200	86-03	MST 307	RAC	250	MST 335			220
KDX	220	KDX225	94-03	MST 307	RAC	250	MST 335			220
	250 R Ninja	EX250K	08-12	MST 421 RAC		290	MST 422 RAC			220
KDX	250	KDX250	91-98	MST 306		250	MST 335			220
KLX	250 R	LX250E	93-98	MST 306		250	MST 336			230
KLX	250 SE	LX250B	93-98	MST 307	RAC	250	MST 336			230
KLX	250 SR	LX250B	93-98	MST 307	RAC	250	MST 336			230
KLX	250		09-	MST 307	RAC	250				
KX	250	KX250M	89-02	MST 306		250	MST 333			220
KX	250	KX250M	03-05	MST 307	RAC	250	MST 339	RAC	EC	240
KX	250	KX250.	06-08	MST 308 RAC	EC	250	MST 339	RAC	EC	240
KX	250 F	KXF250	04-05	MST 307	RAC	250	MST 339	RAC	EC	240
KX	250 F	KXF250	06-14	MST 308 RAC	EC	250	MST 339	RAC	EC	240
KX	250 F	KXF250	15-	MST 282 EC		270	MST 339 EC			240
ZZR	250	EX250H	92-	* MSW 215	RAC	300				
	300 R Ninja	EX300A	13-	MST 267 RAC		290				220
	300 R Ninja ABS	EX300A	13-	MST 267 RAC		290				220
KLX	300	LX300B	96-07	MST 306		250	MST 333			220
Z	300 ABS		15-	MST 267 RAC		290	MST 288 RAC			220
KFX	400	AK47B	03-	MST 402		160	MST 323			220
KLX	400 R	LX400.	03-06	MST 311	RAC	250	MST 341	RAC		220
ZRX	400	ZR400E	94-01	MSW 215	RAC	300				
ZXR	400	ZX400L	89-90	* MSW 215	RAC	300				
ZXR	400	ZX400L/M	91-03	* MSW 214	RAC	310				
ZZR	400	ZX400K/N	90-99	MSW 215	RAC	300				
KFX	450	SF450B	07-	MST 408		163	MST 413			
KLX	450 R	LX450	07-	MST 308 RAC	EC	250	MST 339	RAC	EC	240
KX	450 F	KX450	05-14	MST 308 RAC	EC	250	MST 339	RAC	EC	240
KX	450 F	KXF250	15-	MST 282 EC		270	MST 339 EC			240
KXE	450 F		10-	MST 308 RAC	EC	250	MST 339	RAC	EC	240

	* 2 Scheiben erforderlich – 2 discs required	starre Scheibenausführung – fixed disc	linke Seite – left side	rechte Seite – right side
--	--	--	-------------------------	---------------------------



Kawasaki

EN	500	EN500B/C	94-04			MST 210			300										
KX	500	KX500E	90-03			MST 306			250	MST 333									220
ZZR	500	ZX500C	90-92	AT market	*	MSW 215	RAC		300										
ZZR	500	ZX500D	93-94	AT market	*	MSW 215	RAC		300										
ZR	550 Zephyr	ZR550B	91-99		*	MSW 215	RAC		300										
ZL	600 Eliminator	ZL600B	95-97			MSW 215	RAC		300										
ZX-6R	600 Ninja	ZX600F	95-97		*	MSW 215	RAC		300										
ZX-6R	600 Ninja	ZX600G	98-99		*	MSW 228			296	MST 366	RAC	SL							220
ZX-6R	600 Ninja	ZX600J	00-01		*	MSW 215	RAC		300	MST 366	RAC	SL							220
ZX-6RR	600 Ninja	ZX600K	03-04		*	MSW 238			280	MST 366	RAC	SL							220
ZX-6RR	600 Ninja	ZX600N	05-06		*	MSW 257 RAC			300	MST 366	RAC	SL							220
ZX-6R	600 Ninja	ZX600P	07-08		*	MSW 257 RAC			300	MST 366	RAC	SL							220
ZX-6R	600 Ninja	ZX600R	09-		*	MSW 257 RAC			300	MST 366	RAC	SL							220
ZX-6R	600 Ninja	ZX600R	09-	Racing only	*	MSW 257 SP	RAC-SP		300	MST 366	RAC	SL							220
ZZR	600	ZX600D	90-92		*	MSW 215	RAC		300										
ZZR	600	ZX600E	93-05		*	MSW 215	RAC		300										
ZX-6R	636 Ninja	ZX636A	02		*	MSW 215	RAC		300	MST 366	RAC								220
ZX-6R	636 Ninja	ZX636B	03-04		*	MSW 238			280	MST 366	RAC								220
ZX-6R	636 Ninja	ZX636C	05-06		*	MSW 257 RAC			300	MST 366	RAC								220
ZX-6R	636 Ninja	ZX636E	13-		*	MSW 264 RAC			310	MST 445 RAC									220
ZX-6R	636 Ninja ABS	ZX636E	13-		*	MSW 264 RAC			310	MST 445 RAC									220
ZX-6R	636 Ninja, Ninja ABS	ZX636E	13-	Racing only	*	MSW 264 SP	RAC-SP		310	MST 445 RAC									220
ER-6	650 F	EX650A	05-08		☑	MSW 274 RAC			300	MST 366	RAC								220
ER-6	650 F	EX650A	05-08		☒	MSW 257 RAC			300										
ER-6	650 F ABS	EX650A	05-08		☑	MSW 274 RAC			300	MST 397 RAC									220
ER-6	650 F ABS	EX650A	05-08		☒	MSW 257 RAC			300										
ER-6	650 F	EX650C	09-11		☑	MSW 274 RAC			300	MST 366	RAC								220
ER-6	650 F	EX650C	09-11		☒	MSW 257 RAC			300										
ER-6	650 F ABS	EX650C	09-11		☑	MSW 274 RAC			300	MST 397 RAC									220
ER-6	650 F ABS	EX650C	09-11		☒	MSW 257 RAC			300										
ER-6	650 F	EX650E	12-		☑	MSW 274 RAC			300	MST 366	RAC								220
ER-6	650 F	EX650E	12-		☒	MSW 257 RAC			300										
ER-6	650 F ABS	EX650E	12-		☑	MSW 274 RAC			300	MST 397 RAC									220
ER-6	650 F ABS	EX650E	12-		☒	MSW 257 RAC			300										
ER-6	650 N	ER650A	05-08		*	MSW 257 RAC			300	MST 366	RAC								220
ER-6	650 N ABS	ER650A	05-08		☑	MSW 274 RAC			300	MST 397 RAC									220
ER-6	650 N ABS	ER650A	05-08		☒	MSW 257 RAC			300										
ER-6	650 N	ER650C	09-11		*	MSW 257 RAC			300	MST 366	RAC								220
ER-6	650 N ABS	ER650C	09-11		☑	MSW 274 RAC			300	MST 397 RAC									220
ER-6	650 N ABS	ER650C	09-11		☒	MSW 257 RAC			300										
ER-6	650 N	ER650E	12-		*	MSW 257 RAC			300	MST 366	RAC								220
ER-6	650 N ABS	ER650E	12-		☑	MSW 274 RAC			300	MST 397 RAC									220
ER-6	650 N ABS	ER650E	12-		☒	MSW 257 RAC			300										
KLE	650 Versys ABS	LE650A	07-09		☑	MSW 274 RAC			300	MST 397 RAC									220
KLE	650 Versys ABS	LE650A	07-09		☒	MSW 257 RAC			300										
KLE	650 Versys	LE650A	07-09		*	MSW 257 RAC			300	MST 366	RAC								220
KLE	650 Versys ABS	LE650C	10-14		☑	MSW 274 RAC			300	MST 397 RAC									220
KLE	650 Versys ABS	LE650C	10-14		☒	MSW 257 RAC			300										
KLE	650 Versys ABS		15-		☑	MSW 274 RAC			300	MST 286 RAC									
KLE	650 Versys ABS		15-		☒	MSW 257 RAC			300										
KLX	650	LX650C	93-03						250	MST 336									230
KVF	650 Prairie	KVF650	02-			MST 415			200										
KFX	700	SV700A	07-			MST 408			163										
KVF	700 Brute Force	KVF700	04-06			MST 415			200										
KVF	750 Brute Force	KVF750	05-			MST 415			200										
Z	750	ZR750J	04-06		*	MSW 215	RAC		300	MST 366	RAC								220
Z	750 S	ZR750J	05-07		*	MSW 215	RAC		300	MST 366	RAC								220
Z	750 M	ZR750L	07-11		*	MSW 257 RAC			300	MST 375 RAC									250
Z	750 M ABS	ZR750L	07-11		*	MSW 257 RAC			300	MST 375 RAC									250
Z	750 R	ZR750N	11-12		*	MSW 257 RAC			300	MST 375 RAC									250
Z	750 R ABS	ZR750N	11-12		☑	MSW 274 RAC			300	MST 375 RAC									
Z	750 R ABS	ZR750N	11-12		☒	MSW 257 RAC			300										250
ZR	750 Zephyr	ZR750C	91-95		*	MSW 215	RAC		300										
ZR	750 Zephyr	ZR750D	96-99		*	MSW 215	RAC		300										
ZR-7	750	ZR750F	99-04		*	MSW 215	RAC		300										
ZX-7R	750 Ninja	ZX750N	96-03		*	MSW 216	RAC		320	MST 367									230



Kawasaki											
ZX-7RR	750 Ninja	ZX750N	96-99	*	MSW 216	RAC	320	MST 367		230	
ZXR	750 R	ZX750H	89-90	*	MSW 214	RAC	310	MST 367		230	
ZXR	750 R	ZX750K	91-92	*	MSW 216	RAC	320	MST 367		230	
ZXR	750 R	ZX750M	93-95	*	MSW 216	RAC	320	MST 367		230	
ZXR	750	ZX750J	91-92	*	MSW 216	RAC	320	MST 367		230	
ZXR	750	ZX750L	93-95	*	MSW 216	RAC	320	MST 367		230	
VN	800	VN800A (A)	95-		MST 210		300				
VN	800 Classic	VN800A (B)	96-06		MST 210		300				
VN	800 Drifter	VN800C	99-04		MST 210		300				
W	800 Special Edition, Cafe style	EJ800A	11-		MSW 215	RAC	300				
Z	800	ZR800A	13-	*	MSW 264 RAC		310	MST 375 RAC		250	
Z	800 ABS	ZR800A	13-	*	MSW 264 RAC		310	MST 375 RAC		250	
Z	800 e version	ZR800C	13-	*	MSW 264 RAC		310	MST 375 RAC		250	
Z	800 e version ABS	ZR800C	13-	*	MSW 264 RAC		310	MST 375 RAC		250	
GPZ	900 R	ZX900A	90-98		MSW 215	RAC	300				
ZX-9R	900 Ninja	ZX900B	94-97	*	MSW 216	RAC	320	MST 367		230	
ZX-9R	900 Ninja	ZX900C	98-99	*	MSW 228		296	MST 366	RAC	SL	220
ZX-9R	900 Ninja	ZX900E	00-01	*	MSW 214	RAC	310	MST 366	RAC	SL	220
ZX-9R	900 Ninja	ZX900F	02-04	*	MSW 216	RAC	320	MST 366	RAC	SL	220
GTR	1000	ZGT00A	94-03	*	MSW 215	RAC	300				
KLE	1000 A Versys ABS	LZT00A	12-	*	MSW 257 RAC		300	MST 375 RAC		250	
KLV	1000	BS	04-06	*	MSW 250	RAC	310	MST 368		260	
Z	1000	ZRT00A	03-06	*	MSW 215	RAC	300	MST 366	RAC	220	
Z	1000	ZRT00B	07-09	*	MSW 257 RAC		300	MST 375 RAC		250	
Z	1000 ABS	ZRT00B	07-09	*	MSW 257 RAC		300	MST 375 RAC		250	
Z	1000	ZRT00D	10-13	*	MSW 257 RAC		300	MST 375 RAC		250	
Z	1000 ABS	ZRT00D	10-13	*	MSW 257 RAC		300	MST 375 RAC		250	
Z	1000	ZXT00F	14-	*	MSW 264 RAC		300	MST 375 RAC		250	
Z	1000 ABS	ZXT00F	14-	*	MSW 264 RAC		300	MST 375 RAC		250	
Z	1000 SX	ZXT00G	10-13	*	MSW 257 RAC		300	MST 375 RAC		250	
Z	1000 SX ABS	ZXT00G	10-13	*	MSW 257 RAC		300	MST 375 RAC		250	
Z	1000 SX	ZXT00L	14-	*	MSW 264 RAC		300	MST 375 RAC		250	
Z	1000 SX ABS	ZXT00L	14-	*	MSW 264 RAC		300	MST 375 RAC		250	
ZX-10R	1000 Ninja	ZXT100C	04-05	*	MSW 257 RAC		300	MST 366	RAC	SL	220
ZX-10R	1000 Ninja	ZXT100D	06-07	*	MSW 257 RAC		300	MST 366	RAC	SL	220
ZX-10R	1000 Ninja	ZXT100E	08-09	*	MSW 264 RAC		310	MST 366	RAC	SL	220
ZX-10R	1000 Ninja	ZXT100F	10	*	MSW 264 RAC		310	MST 445 RAC		220	
ZX-10R	1000 Ninja	ZXT100J	11-	*	MSW 264 RAC		310	MST 445 RAC		220	
ZX-10R	1000 Ninja ABS	ZXT100J	11-	*	MSW 264 RAC		310	MST 445 RAC		220	
ZX-10R	1000 Ninja, Ninja ABS	ZXT100J	11-	Racing only	MSW 264 SP	RAC-SP	310	MST 445 RAC		220	
GPZ	1100	ZXT10E	95-99	*	MSW 215	RAC	300				
ZR	1100 Zephyr	ZRT10A/B	93-97	*	MSW 214	RAC	310				
ZRX	1100	ZRT10C	97-00	*	MSW 214	RAC	310				
ZZR	1100	ZXT10C	90-92	*	MSW 214	RAC	310				
ZZR	1100	ZXT10D	93-01	*	MSW 216	RAC	320				
ZRX	1200 R, S	ZRT20A/B	01-	*	MSW 214	RAC	310				
ZX-12R	1200 Ninja	ZXT20A	00-03	*	MSW 216	RAC	320				
ZX-12R	1200 Ninja	ZXT20A	04-06	*	MSW 215	RAC	300				
ZZR	1200	ZXT20C	02-04	*	MSW 216	RAC	320				
GTR	1400 ABS	ZG1400A	07-09	*	MSW 264 RAC		310			250	
GTR	1400 ABS	ZG1400C	10-	*	MSW 264 RAC		310			250	
ZZR	1400 ABS	ZXT40A	06-07	*	MSW 264 RAC		310	MST 375 RAC		250	
ZZR	1400 ABS	ZXT40C	08-11	*	MSW 264 RAC		310	MST 375 RAC		250	
ZZR	1400 ABS	ZXT40E	12-	*	MSW 264 RAC		310	MST 375 RAC		250	
VN	1500 Mean Streak	VNT50P	02-04		MSW 216	RAC	320				
VN	1500 Sumo	VNT50A	94-96		MST 210		300				
VN	1500 Classic	VNT50D	96-		MST 210		300				
VN	1600 Mean Streak	VNT60B	04-		MSW 216	RAC	320				
KTM											
	50 Kross	KTMG50	96-		MST 236	RAC	190				
SX	85	SX85	04-10	14"	MST 309 RAC	EC	220	MST 314 RAC	EC	200	
SX	85		11-	14"	MST 309 RAC	EC	220	MST 463 EC		210	

	* 2 Scheiben erforderlich – 2 discs required		linke Seite – left side
	starre Scheibenausführung – fixed disc		rechte Seite – right side



Option 1

Option 2



Option 1

Option 2



KTM

SX	85	SX85	04-11	16"	MST 309 RAC	EC		220	MST 314 RAC	EC		200
SX	85		12-	16"				220	MST 463 EC			210
	125 Duke ABS		13-		MST 271 RAC			300	MST 272 RAC			230
RC	125 ABS		14-		MST 271 RAC			300	MST 272 RAC			230
	125 Sting	KTM 125	98-		MSW 314			320	MST 266	RAC	EC	220
EXC	125	KTM-2T-EXC	98-		MST 265	RAC	EC	260	MST 266	RAC	EC	220
MX	125		94-95		MST 265	RAC	EC	260	MST 266	RAC	EC	220
SX	125	VBKMXH...	96-		MST 265	RAC	EC	260	MST 266	RAC	EC	220
SX	150		09-		MST 265	RAC	EC	260	MST 266	RAC	EC	220
XC	150		09-		MST 265	RAC	EC	260	MST 266	RAC	EC	220
	200 Duke ABS		12-		MST 271 RAC			300	MST 272 RAC			230
RC	200 ABS		14-		MST 271 RAC			300	MST 272 RAC			230
EXC	200	KTM-2T-EXC	98-		MST 265	RAC	EC	260	MST 266	RAC	EC	220
SX	200	VBKMXK...	03-		MST 265	RAC	EC	260	MST 266	RAC	EC	220
XC-W	200		03-		MST 265	RAC	EC	260	MST 266	RAC	EC	220
EXC	250	KTM-2T-EXC	03-		MST 265	RAC	EC	260	MST 266	RAC	EC	220
EXC-F	250	KTM-2T-EXC	03-		MST 265	RAC	EC	260	MST 266	RAC	EC	220
GS	250		94-97		MST 265	RAC	EC	260	MST 266	RAC	EC	220
SX	250	VBKMXN...	94-02		MST 265	RAC	EC	260	MST 266	RAC	EC	220
SX	250	VBKMXN...	03-		MST 265	RAC	EC	260	MST 266	RAC	EC	220
SX-F	250	SXF250	06-		MST 265	RAC	EC	260	MST 266	RAC	EC	220
XC	250		03-		MST 265	RAC	EC	260	MST 266	RAC	EC	220
XC-F	250		06-		MST 265	RAC	EC	260	MST 266	RAC	EC	220
XC-W	250		03-		MST 265	RAC	EC	260	MST 266	RAC	EC	220
EXC	300	KTM-2T-EXC	98-		MST 265	RAC	EC	260	MST 266	RAC	EC	220
GS	300		93-		MST 265	RAC	EC	260	MST 266	RAC	EC	220
SX	300	SX300	94-02		MST 265	RAC	EC	260	MST 266	RAC	EC	220
XC	250		98-		MST 265	RAC	EC	260	MST 266	RAC	EC	220
XC-W	250		98-		MST 265	RAC	EC	260	MST 266	RAC	EC	220
GS	350 4 T		93-97		MST 265	RAC	EC	260	MST 266	RAC	EC	220
EXC-F	350		10-		MST 265	RAC	EC	260	MST 266	RAC	EC	220
XCF-W	350		10-		MST 265	RAC	EC	260	MST 266	RAC	EC	220
SX-F	350		10-		MST 265	RAC	EC	260	MST 266	RAC	EC	220
XC-F	350		10-		MST 265	RAC	EC	260	MST 266	RAC	EC	220
EXC	380	EXC380	98-02		MST 265	RAC	EC	260	MST 266	RAC	EC	220
SX	380	SX380	96-02		MST 265	RAC	EC	260	MST 266	RAC	EC	220
	390 Duke ABS		13-		MST 271 RAC			300	MST 272 RAC			230
RC	390 ABS		14-		MST 271 RAC			300	MST 272 RAC			230
EXC	400	KTM-4T-EXC	94-		MST 265	RAC	EC	260	MST 266	RAC	EC	220
LC4	400 EGS 4 T	KTM-4T-EGS	96-02		MST 310			300				
SX	400	SX400	00-10		MST 265	RAC	EC	260	MST 266	RAC	EC	220
EXC	450	KTM-4T-EXC	03-		MST 265	RAC	EC	260	MST 266	RAC	EC	220
SMR	450 Supermoto		05-12						MST 266	RAC	EC	220
SX-F	450	VBKMXN...	03-		MST 265	RAC	EC	260	MST 266	RAC	EC	220
XC	450		08-		MST 384			180	MST 385			200
XC-F	450	KTM-4T-EXC	03-		MST 265	RAC	EC	260	MST 266	RAC	EC	220
XCF-W	450	KTM-4T-EXC	03-		MST 265	RAC	EC	260	MST 266	RAC	EC	220
EXC	500		12-		MST 265	RAC	EC	260	MST 266	RAC	EC	220
MX	500	MX500	94-99		MST 265	RAC	EC	260	MST 266	RAC	EC	220
SX	500	SX500	94-99		MST 265	RAC	EC	260	MST 266	RAC	EC	220
XCF-W	500		12-		MST 265	RAC	EC	260	MST 266	RAC	EC	220
SX-F	505	SXF505	07-		MST 265	RAC	EC	260				
XC	505		08-		MST 384			180	MST 385			200
EXC	520	KTM-4T-EXC	00-02		MST 265	RAC	EC	260	MST 266	RAC	EC	220
SX	520	VBKMXM...	00-02		MST 265	RAC	EC	260	MST 266	RAC	EC	220
EXC	520	VBKMXM...	00-02		MST 265	RAC	EC	260	MST 266	RAC	EC	220
SMR	525 Supermoto		05-07						MST 266	RAC	EC	220
EXC	525	KTM-4T-EXC	03-07		MST 265	RAC	EC	260	MST 266	RAC	EC	220
SX	525	VBKMXM...	03-07		MST 265	RAC	EC	260	MST 266	RAC	EC	220
XC	525 Racing		06-		MST 265	RAC	EC	260				
EXC	530		08-12		MST 265	RAC	EC	260	MST 266	RAC	EC	220
XCF-W	530		08-12		MST 265	RAC	EC	260	MST 266	RAC	EC	220
LC4	540		99-00		MST 265	RAC	EC	260	MST 266	RAC	EC	220
SMR	560 Supermoto		05-12						MST 266	RAC	EC	220
LC4	600 4 T		89-90						MST 340			220
LC4	600 4 T		94-00		MST 265	RAC	EC	260	MST 266	RAC	EC	220



KTM											
LC4	620 EGS	KTM-4T-EGS	96-02		MST 310			300			
	620 Duke		95-98		MSW 114 RAC			320	MST 266	RAC	EC 220
LC4	620 Adventure		96-99		MST 310			300	MST 266	RAC	EC 220
LC4	625 SC Supercomp.	KTM-4T-EGS	01-02		MST 265	RAC	EC	260	MST 266	RAC	EC 220
LC4	625 SXC Supercomp.	KTM-4T-EGS	02-07		MST 265	RAC	EC	260	MST 266	RAC	EC 220
	640 Duke II	KTM DKII	99-02		MSW 114 RAC			320	MST 266	RAC	EC 220
LC4	640	KTM-4T-EGS	01-03		MST 310			300			
LC4	640 Supermoto	KTM-4T-EGS	03-		MSW 114 RAC			320	MST 266	RAC	EC 220
LC4	640 Adventure	KTM-4T-EGS	00		MST 310			300	MST 266	RAC	EC 220
LC4	640 Adventure	KTM-4T-EGS	01-02		MSW 114 RAC			320	MST 266	RAC	EC 220
LC4	640 Enduro	KTM-4T-EGS	06-07		MST 310			300	MST 266	RAC	EC 220
LC4	660 SMC Supermoto	4T-SC	03-07		MSW 114 RAC			320	MST 266	RAC	EC 220
	660 Rally	KTM Rally	99-03		MST 310			300	MST 266	RAC	EC 220
	690 Duke	KTM Duke	08-11	cast wheel	MSW 211	RAC		320	MST 378 RAC		240
	690 Duke R	KTM Duke	10-11	cast wheel	MSW 211	RAC		320	MST 378 RAC		240
	690 Duke ABS	KTM Duke	12-		MSW 289 RAC			320	MST 378 RAC		240
	690 Duke R ABS	KTM Duke	13-		MSW 289 RAC			320	MST 378 RAC		240
	690 Enduro, Enduro R	KTM 690 LC4	08-		MSW 277 RAC			300	MST 439		240
LC4	690 SM, SMC, SM-LE	KTM LC-4	07-		MSW 114 RAC			320	MST 439		240
LC4	690 SM Prestige	KTM LC-4	07	cast wheel	MSW 114 RAC			320	MST 378 RAC		240
LC4	690 SMR	KTM LC-4 SM	08-09	cast wheel	MSW 211	RAC		320	MST 378 RAC		240
LC8	950 Super Enduro	KTM LC-8 SE	07-09		MSW 277 RAC			300	MST 439		240
LC8	950 SMR, SMT	KTM LC-8	07-10		* MSW 282 RAC			305	MST 378 RAC		240
LC8	990 Adventure S	KTM LC-8	06-08		MSW 277 RAC			300	MST 439		240
LC8	990 Adventure R, ABS	KTM LC-8	09-12		MSW 277 RAC			300	MST 438		240
LC8	990 SMR, ABS	KTM LC-8 SM	09-12		* MSW 282 RAC			305	MST 378 RAC		240
LC8	990 SMT, ABS	KTM LC-8 SM	11-		* MSW 282 RAC			305	MST 378 RAC		240
LC8	990 Super Duke	KTM LC-8	05-11	cast wheel	* MSW 211	RAC		320	MST 378 RAC		240
LC8	990 Super Duke R	KTM LC-8	08-	cast wheel	* MSW 211	RAC		320	MST 378 RAC		240
	1050 Adventure ABS		15-		* MSW 207			320	MST 290		256
RC8	1190 R	KTM RC-8	08-		* MSW 211	RAC		320			
	1290 Adventure ABS		15-		* MSW 207			320	MST 290		256
	1290 Super Duke R ABS		15-		* MSW 205 RAC			320	MST 289 RAC		240
Kymco											
	50 Agility		05-08		MST 256			180			
	50 Agility	CV50QTS	06-	10"	MST 256			180			
	50 Agility	CK50QTS	06-	12"	MST 256			180			
	50 Cobra Cross	SF10	00-06		MST 256			180	MST 256		180
	50 Cobra Racer	SF10	00-06		MST 256			180	MST 256		180
	50 Heroism	KCZ	95-		MST 241			162			
	50 People 2T	B9	07-		MST 260	RAC		200			
KB	50	KB	95-00		MST 241			162			
	50 K 12, Scout	K12	95-		MST 241			162			
	50 Calypso	KCZ	97-		MST 241			162			
	50 Dink	KCZ	98-06		MST 256			180			
	50 Topboy	SF10	98-05		MST 256			180			
CX	50 Super	KCP	95-		MST 241			162			
	50 Mxer	L2	00-		MST 256			180	MST 256		180
	50 Super 9, AC, LC	S1	00-06		MST 256			180	MST 256		180
	50 Sniper		93-		MST 241			162			
	50 Sniper DD		94-		MST 241			162			
	50 Spacer	SH10	98-		MST 256			180	MST 256		180
	50 Super Fever, Scout	KCA	99-06		MST 256			180	MST 256		180
	50 Super Fever, Scout	SC10	99-06		MST 256			180	MST 256		180
	50 Vitality Cross, Sport	U3	05-09		MST 256			180	MST 256		180
	50 Yager	SH10	98-		MST 256			180	MST 256		180
	50 Yup	S6	02-09		MST 256			180	MST 256		180
	90 Maxxer		05-06		MST 256			180			
KB	100 Manboy	KB	97-00		MST 241			162			
	125 Agility	CK125T-6	06-10	12"	MST 256			180	MST 256		180
	125 Calypso	KAF	97-		MST 241			162			
	125 Dink, Dink LX	SH30	97-04		MST 256			180	MST 256		180

	* 2 Scheiben erforderlich – 2 discs required
	starre Scheibenausführung – fixed disc
	linke Seite – left side
	rechte Seite – right side



Option 1

Option 2



Option 1

Option 2

**Kymco**

	125 Grand Dink	S4	01-02	MST 256		180	MST 256		180
	125 Heroism	KAF	95-97	MST 241		162			
	125 Movie	S5	01-	MST 256		180	MST 256		180
	125 Mxer	L1	02-	MST 256		180	MST 256		180
	125 Spacer	SH25	97-	MST 256		180	MST 256		180
	125 Yager	SH	00-	MST 256		180	MST 256		180
	150 Heroism	KBF	95-97	MST 241		162			
	150 Dink	S3	97-	MST 256		180	MST 256		180
	150 Grand Dink	S4	01-02	MST 256		180	MST 256		180
	150 Mxer	L1	02-	MST 256		180	MST 256		180
	150 Spacer		97-	MST 256		180	MST 256		180

Laverda

	650 Sport	ZLVSTA...	95-01	* MSW 211	RAC	320	MST 247	RAC	245
	650 Ghost	ZLVSPA...	96-97	* MSW 211	RAC	320	MST 247	RAC	245
	750 S Formula	ZLVSTA...	98-01	* MSW 211	RAC	320	MST 247	RAC	245
	750 Strike	Strike	98-01	* MSW 211	RAC	320	MST 247	RAC	245
	1000 SFC		03-	* MSW 211	RAC	320			

Malaguti

	50 Centro	ZJM42D	94-00	MST 260	RAC	200			
	50 Ciak	52	00-03	MST 252	RAC	190	MST 252	RAC	190
	50 Yesterday	ZJM45	98-	MST 258		155			
CR-1	50 Crosser	ZJM43	95-01	MST 252	RAC	190	MST 252	RAC	190
DVD	50 Malbo Line		10-	MST 250		155			
F-10	50 Jetline	ZJM39D	92-	MST 258		155			
F-12	50 Phantom	ZJM40	94-	MST 252	RAC	190	MST 252	RAC	190
F-12	50 Phantom	ZJM41D	94-08	MST 252	RAC	190	MST 252	RAC	190
F-15	50 Firefox	ZJM44	96-97	MST 252	RAC	190			
F-15	50 Firefox LC	ZJM44	98-08	MST 252	RAC	190	MST 252	RAC	190
	100 Ciak		00-03	MST 252	RAC	190	MST 252	RAC	190
F-12	100 Phantom	ZJM46	99-				MST 252	RAC	190

MBK

CR	50 Target	4BX	92-94	MST 250		155			
CS	50 Mach G	SA22	02-10	MST 236	RAC	190			
CV	50 Evolis	4FW	92-97	MST 250		155			
CW	50 Booster Spirit	4BX	95-98	MST 250		155			
CW	50 Booster Spirit	SA05	99	MST 257		180			
CW	50 Booster Next G.	4BXM	95-00	MST 257		180			
CW	50 RS Booster Next G.	4BX	01-06	MST 243	RAC	190			
CW	50 Booster Track	4VA	96-	MST 257		180			
CW	50 Booster Rocket	4VA	97-	MST 257		180			
CW	50 Booster Road	4BX	93-95	MST 250		155			
CW	50 Booster Naked	SA05	06-	MST 257		180			
CW	50 Fizz	4RC	94-97	MST 250		155			
CW	50 Power Rocket	SA05	06-	MST 257		180			
CY	50 Forte	3UG	94-97	MST 250		155			
EW	50 Stunt	SA09	00-06	MST 243	RAC	190			
EW	50 Stunt Naked	SA09	05-	MST 243	RAC	190			
YN	50 Ovetto	5AD	97-10	MST 236	RAC	190			
YQ	50 Nitro, Nitro Naked	5BR	97-10	MST 243	RAC	190	MST 243	RAC	190
CV	80 Evolis	4FW	97	MST 250		155			
YN	100 Ovetto	SB04	00-03	MST 236	RAC	190			
YQ	100 Nitro	SB05	99-03	MST 243	RAC	190			
	125 Doo Do	SE04	00-05	MST 259		220			
XQ	125 Thunder	SE05	01-	MST 370		245	MST 259		220
YP	125 Skyliner	SE02	98-	MST 259		220			
YP	125 Skyliner	SE06	01-06	MST 259		220			
YP	125 Skyliner	SE43	07-	MST 259		220			
	125 Skycruiser	SE32	06-10	MSW 269		267			
XQ	150 Thunder	SG06	01-	MST 370		245	MST 259		220
YP	150 Skyliner	SG08	98-	MST 259		220			
YP	180 Skyliner	SG12	03-	MST 259		220			
YP	250 Skyliner	SG02	96-00	MST 247		245			
YP	400 Skyliner	SH05	04	MSW 269		267			



Option 1

Option 2



Option 1

Option 2

**Moto Guzzi**

	750 Brevia i.e.	LL	03-12		MSW 211	RAC	320			
V7	750 Classic, Cafe Classic	LW	07-12		MSW 211	RAC	320			
V7	750 Racer, Special, Stone	LW	10-		MSW 211	RAC	320			
V7	750 II Stone, Special, Racer, ABS		15-		MSW 211	RAC	320			
	750 Nevada	LM	05-	*	MSW 211	RAC	320			
	850 Brevia i.e.	LP	07-09		MSW 211	RAC	320			
	850 Griso	LS	07-		MSW 211	RAC	320			
	850 Norge	LP	07		MSW 211	RAC	320			
	936 Bellagio		08-	*	MSW 211	RAC	320			
	940 Custome	LY	07-	*	MSW 211	RAC	320			
V	1000 G5	VG	95-		MSW 211	RAC	320			
RS	1000 Daytona I.E.	KA	92-94	*	MSW 221	RAC	300			
RS	1000 Daytona	KL	95-	*	MSW 211	RAC	320			
V10	1000 Centauro, SP	KK	97-99	*	MSW 211	RAC	320			
	1000 Convert		96-		MSW 211	RAC	320			
	1100 Brevia	LP	05-		MSW 211	RAC	320			
	1100 Griso	LS	07-	*	MSW 211	RAC	320			
	1100 Sport	KR	95-97		MSW 211	RAC	320			
EV	1100 California SP	KD	97-	*	MSW 211	RAC	320			
EV	1100 California	KD	98-	*	MSW 211	RAC	320			
EV	1100 California Jackal	KD	94-01	*	MSW 211	RAC	320			
EV	1100 Touring	KD	03-05		MSW 211	RAC	320			
	1100 California Aquila Nera	KD	09-11		MSW 211	RAC	320			
	1100 California Classic Touring	KD	06-08		MSW 211	RAC	320			
	1100 California Stone	KD	01-05		MSW 211	RAC	320			
	1100 California Vintage	KD	06-	*	MSW 211	RAC	320			
	1100 California 90	KD	12-	*	MSW 211	RAC	320			
V11	1100 Ballabio		03-05	*	MSW 211	RAC	320			
V11	1100 Le Mans, Scura, Naked	KR	00-05	*	MSW 211	RAC	320			
V11	1100 Sport	KF	99-06	*	MSW 211	RAC	320			
	1200 Brevia	LP	08-	ABS	*	MSW 211	RAC	320		
	1200 Griso 8V	LS	07-		MSW 211	RAC	320			
GT	1200 Norge	LS	06-10	ABS	*	MSW 211	RAC	320		
GT	1200 Norge GT ABS	LS	11-		MSW 211	RAC	320			
	1200 Sport 4V	LP	06-		MSW 211	RAC	320			
	1200 Stelvio	LZ	08-10	ABS	*	MSW 211	RAC	320		
	1200 Stelvio 8V ABS		11-		MSW 211	RAC	320			

MUZ

FB	Moskito	FB	97-03		MST 250		155			
SX	Moskito	JP	00-03		MST 250		155			
MZ	Baghira, Black Panther	MUZ660E	96-05		MST 233		280			

MV Agusta

	675 Brutale, ABS	B310	12-		* MSW 203 RAC		320			
F3	675 , ABS	F310	11-		* MSW 203 RAC		320			
F3	675 , ABS	F310	11-	Racing only	* MSW 203 SP	RAC-SP	320			
	800 Brutale, Brutale ABS		13-		* MSW 203 RAC		320			
	800 Brutale Dragster		14-		* MSW 203 RAC		320			
	800 Rivale, ABS	S310	13-		* MSW 203 RAC		320			
	800 Stradale, ABS		15-		* MSW 203 RAC		320			
	800 Turismo Veloce, ABS		14-		* MSW 203 RAC		320			
F3	800 , ABS		14-		* MSW 203 RAC		320			
F3	800 , ABS		14-	Racing only	* MSW 203 SP	RAC-SP	320			
F4	1000 R, ABS		12-	Racing only	* MSW 206 SP	RAC-SP	320			
F4	1000 RR, ABS		12-	Racing only	* MSW 206 SP	RAC-SP	320			

Norton

	961 Commando Sport	COM 01	10-		* MSW 211	RAC	320			
	961 Commando SE, SF	COM 01	10-		* MSW 211	RAC	320			
	961 Commando Cafe Racer	COM 01	10-		* MSW 211	RAC	320			

Peugeot

	50 Buxy	FE053DE	94-		MST 252	RAC	190			
--	---------	---------	-----	--	---------	-----	-----	--	--	--



* 2 Scheiben erforderlich – 2 discs required
 EX starre Scheibenausführung – fixed disc

☑ linke Seite – left side
 ☑ rechte Seite – right side



Option 1

Option 2



Option 1

Option 2



Peugeot

	50 Elyseo	G1A	98-02		MST 252	RAC	190			
	50 Elyseo	G1A	03		MST 261	RAC	180	MST 261	RAC	180
	50 Elystar Advantage	G1A	02-07		MST 261	RAC	180	MST 261	RAC	180
	50 Looxor TSDi	B1	06-		MST 252	RAC	190	MST 252	RAC	190
	50 Ludix Elegance	L1	04-		MST 252	RAC	190	MST 252	RAC	190
	50 Ludix Pro	L1	11-	14"	MST 252	RAC	190	MST 252	RAC	190
	50 TKR Metal-X	S1A	02-03		MST 252	RAC	190			
	50 TKR, WRC	S1A	99-08		MST 252	RAC	190			
	50 TKR Furious	S1A	03-11		MST 252	RAC	190			
	50 TKR	S1A	09-	10",12"	MST 252	RAC	190			
	50 Trekker	S1ADE	97-00		MST 252	RAC	190			
	50 Squab	S1ADE	94-01		MST 252	RAC	190			
	50 Speedake	FE053DE	95-01		MST 252	RAC	190			
	50 Speedfight SC, L	S1BDE	97-08		MST 261	RAC	180	MST 261	RAC	180
	50 V-Clic	AG	08-		MST 250		155			
	50 Vivacity	S1C	92-11		MST 252	RAC	190			
	50 Zenith Luxe	FE052ADE	96-		MST 258		155			
SV	50	F052DE	92-		MST 252	RAC	190			
SV	50 Geo	F082	92-		MST 252	RAC	190			
	100 Elyseo	G12A	03		MST 261	RAC	180	MST 261	RAC	180
	100 Looxor	P2A	01-04		MST 252	RAC	190	MST 252	RAC	190
	100 Speedfight SC	S1BDE	97-07		MST 261	RAC	180	MST 261	RAC	180
	100 Trekker	S2A	98		MST 252	RAC	190			
	100 Vivacity	S2A	99-08		MST 252	RAC	190	MST 252	RAC	190
SV	125 Geo	F121	91-		MST 252	RAC	190			
	125 Geo RS	N2	06-13		MST 466		263			
	125 Geopolis Executive	N2	06-13		MST 466		263			
	125 Geopolis ABS	N2	06-13		MST 466		263			
	125 Looxor	P2	03-04		MST 252	RAC	190	MST 252	RAC	190
	125 Ludix Ambition	L1A	04-		MST 252	RAC	190	MST 252	RAC	190
	125 Satelis City 4V	J2A	06-09		MST 466		263			
	125 Satelis Compressor	J2A	06-12		MST 466		263			
	125 Satelis Executive 4V	J2A	06-09		MST 466		263			
	125 Satelis Premium 4V	J2A	06-09		MST 466		263			
	125 Satelis II i., ABS	J2B	12-		MST 466		263			
	150 Looxor	P2A	03-04		MST 252	RAC	190	MST 252	RAC	190
SV	250	N2	01-02		MST 453		240	MST 245		220
	250 Geo	N2	07-11		MST 466		263			
	250 Geopolis Executive	N2	07-11		MST 466		263			
	250 Geopolis Premium	N2	07-11		MST 466		263			
	250 Geopolis Urban ABS	N2	07-11		MST 466		263			
	300 Geo RS	N2	10-12		MST 466		263			
	300 Geopolis Premium	N2	10-		MST 466		263			
	300 Geostyle	N2	10-12		MST 466		263			
	300 Satelis i	J2	14-		MST 466		263			
	400 Geo RS	N2	08-12		MST 466		263			
	400 Geopolis Premium	N2	07-12		MST 466		263			
	400 Geopolis Urban ABS	N2	07-12		MST 466		263			
	400 Satelis i	J2	14-	*	MST 466		263			
	500 Geopolis	N2	07-11	*	MST 466		263			
	500 Satelis	J2	06-12	*	MST 466		263			

PGO

	50 Big Max	PM	95-06		MST 250		155			
	50 Mega fifty		99		MST 250		155			
	50 Rodoshow	PE	01-09		MST 250		155			
	50 T-Rex	CP	99-09		MST 243	RAC	190	MST 243	RAC	190
	50 Tornado	PT	97		MST 250		155			
PMS	50	PM	99-03		MST 243	RAC	190			
PMX	50	PM	99-03		MST 243		155	MST 243	RAC	190
	80 Big Max	PS	95-		MST 250		155			
	125 BuBu		03-		MST 243	RAC	190			
	125 Ligero		06-		MST 243	RAC	190			
	125 Tornado		97-		MST 250		155			
	125 T-Rex	CP0	99-		MST 243	RAC	190	MST 243	RAC	190
	150 T-Rex	CP2	99-		MST 243	RAC	190			



Option 1

Option 2



Option 1

Option 2



Piaggio

	50 Diesis	C34	01-05		MST 236	RAC	190			
	50 Fly	C44	05-07		MST 260	RAC	200			
	50 Free	FCS	97-02		MST 260	RAC	200			
	50 Liberty	C15	97-08		MST 396		220			
	Liberty Elettrico		11-		MST 396		220			
	50 Stalker	C13	97-		MST 236	RAC	190			
	50 Quartz	NSP	91-95		MST 260	RAC	200			
	50 Zip Fast Rider	SSL	93-99		MST 250		155			
	50 Zip Base	SSL	95-96		MST 250		155			
	50 Zip S.P., LC	C11	96-		MST 260	RAC	200			
	50 Zip Catalyzer	C25	00		MST 250		155			
	50 Zip 2T, 4T	C25	00-		MST 255		175			
ET2	50	C12	97-05	Vespa	MST 260	RAC	200			
ET2	50	C16	97-05	Vespa	MST 260	RAC	200			
ET4	50		00-04	Vespa	MST 260	RAC	200			
NRG	50 Scooter	SAL	94-98		MST 236	RAC	190			
NRG	50 Extreme AC	C21	99-01		MST 254		220	MST 255		174
NRG	50 Extreme LC	C22	99-01		MST 254		220	MST 255		174
NRG	50 RST	C21	96-98		MST 236	RAC	190	MST 255		174
NRG	50 mc2 SP	C04	99-		MST 254		220	MST 255		174
NRG	50 mc3 DD, DT	C30	01-05		MST 254		220	MST 255		174
NRG	50 DD, DT Power	C45	05-		MST 396		220	MST 255		174
NRG	50 Power Pure Jet	C32	03-09		MST 396		220	MST 255		174
NRG	50 Silver Bullet		10-		MST 396		220	MST 255		174
NTT	50	SAL	94-96		MST 236	RAC	190			
LX	50	C38	05-	Vespa	MST 260	RAC	200			
LXV	50	C38	07-09	Vespa	MST 396		220			
RST	50 Sfera	NSL/C01	95-99		MST 260	RAC	200			
S	50 , Sport	C38	07-	Vespa	MST 260	RAC	200			
TPH	50 Typhoon	TEC	94-00		MST 236	RAC	190			
TPH	50 Typhoon	C29	01-09		MST 236	RAC	190			
	80 Skipper		94-		MST 260	RAC	200			
TPH	80 Typhoon	TEC80	96-		MST 254		220			
	100 Diesis		01-03		MST 236	RAC	200			
	100 Fly 4T	M53	06-		MST 260	RAC	200	MST 260	RAC	200
	100 Free		02-		MST 260	RAC	200			
	100 Zip	M53	06-		MST 260	RAC	200	MST 260	RAC	200
	125 Beverley	M28	02-09		MST 298		260	MST 298		260
	125 Carnaby	M60	07-09		MST 298		260	MST 298		260
	125 Free		05-		MST 260	RAC	200			
	125 Fly	M42	05-		MST 260	RAC	200			
	125 Typhoon	M02	95-03		MST 236	RAC	190			
	125 Hexagon	M05	98-		MST 260	RAC	200			
	125 MP3 RL/LT ie	M47	06-11		MST 394		240	MST 395		240
	125 ie MP3 YOUrban	M75	11-		MST 394		240	MST 395		240
	125 MP3 Hybrid	M75	09-		MST 394		240	MST 395		240
	125 New Fly ie		12-		MST 236		190	MST 396		220
	125 Skipper	M12	93-97		MST 260	RAC	200			
	125 Skipper	M21	98-		MST 254		220			
	125 XEvo	M36	07-		MST 393		260	MST 395		240
	125 Zip	M25	00-		MST 260	RAC	200			
ET4	125 Vespa	M04	97-05		MST 260	RAC	200			
GT	125 Granturismo	M31	04-06	Vespa	MST 396		220	MST 396		220
GTS	125 , Super/Sport	M31	07-	Vespa	MST 396		220	MST 396		220
GTV	125	M31	07-09	Vespa	MST 396		220	MST 396		220
GTX	125 Super Hexagon	M20	00		MST 260	RAC	200	MST 260	RAC	200
GTX	125 Super Hexagon		01-03		MST 395		240	MST 396		220
	125 MP3		06-10		MST 394		240			
LE	125 Liberty	M22	98-08		MST 396		220			
LE	125 Liberty 4T		09-		MST 396		220			
LX	125	M44	05-	Vespa	MST 260		200			
LXV	125	M44	07-	Vespa	MST 396		220			



* 2 Scheiben erforderlich – 2 discs required
 EX starre Scheibenausführung – fixed disc

☑ linke Seite – left side
 ☑ rechte Seite – right side



Option 1

Option 2



Option 1

Option 2

**Piaggio**

PX	125	M09	98-	Vespa	MST 260	RAC	200			
RST	125 Sfera	M01	96-99		MST 260	RAC	200			
S	125 , Sport		07-	Vespa	MST 260	RAC	200			
X7	125	M62	08-09		MST 393		260	MST 395		240
X7	125 Evo ie	M62	09-		MST 393		260	MST 395		240
X8	125	M36	04-06		MST 393		260	MST 395		240
X8	125 ie	M36	07-10		MST 298		260	MST 395		240
X8	125 Street	M36	07-10		MST 298		260			
	150 Fly 4T		05-		MST 260	RAC	200			
	150 Liberty	M67	08-		MST 396		220			
	150 Skipper	CVM	93-97		MST 260	RAC	200			
	150 Skipper	CVM	98-		MST 254		220			
ET4	150	M04	99-		MST 260	RAC	200			
LX	150	M68	05-09	Vespa	MST 260	RAC	200			
PX	150	M74	98-	Vespa	MST 260	RAC	200			
S	150 , Sport	M68	07-	Vespa	MST 260	RAC	200			
X8	150 Street	M36	07-		MST 298		260			
GTX	180 Super Hexagon	M20	00		MST 260	RAC	200	MST 260	RAC	200
	180 Hexagon LX/LXT/LX4	M06	98-99		MST 260	RAC	200			
	200 Beverly GT	M28	02-07		MST 298		260	MST 298		260
	200 Carnaby	M60	07-09		MST 298		260	MST 298		260
	200 Liberty	M22	07-08		MST 396		220	MST 396		220
PX	200 PE	P200E	98-07	Vespa	MST 260	RAC	200			
GT	200 L Granturismo	M31	03-06	Vespa	MST 396		220	MST 396		220
X8	200	M36	04-06		MST 393		260	MST 395		240
	250 Beverly ie	M28	04-08		MST 298		260	MST 298		260
	250 Carnaby ie	M60	08-09		MST 298		260	MST 298		260
	250 MP3 LT/RL	M59	06-09		MST 394		240	MST 395		240
	250 Xevo ie	M36	07-10		MST 393		260	MST 395		240
GTS	250 ie, ABS	M45	06-11	Vespa	MST 396		220	MST 396		220
GTV	250 ie	M45	07-10	Vespa	MST 396		220	MST 396		220
GT	250 Hexagon		98-99		MST 260	RAC	200			
GTX	250 Super Hexagon	M14	00-02		MST 260	RAC	200	MST 260	RAC	200
GT	250 Hexagon	M14	98-		MST 260	RAC	200			
X7	250 ie	M62	08-09		MST 393		260	MST 395		240
X8	250 ie	M36	05-06		MST 393		260	MST 395		240
X8	250 ie	M36	07		MST 298		260	MST 395		240
X9	250	M27	04		MST 393		260	MST 395		240
GTS	300 ie, Super,Touring	M45	10-	Vespa	MST 396		220	MST 396		220
GTV	300 ie	M45	07-	Vespa	MST 396		220	MST 396		220
	300 Carnaby Cruiser	M60	08-11		MST 298		260	MST 298		260
	300 Carnaby ie	M60	12-		MST 298		260	MST 298		260
	300 MP3 YOUrban LT ie	M71	10-		MST 394		240	MST 395		240
	300 MP3 LT Sport ie	M71	10-		MST 394		240	MST 395		240
	300 MP3 LT Business ie	M71	10-		MST 394		240	MST 395		240
X7	300 Evo ie	M62	10-		MST 393		260	MST 395		240
	400 Beverly ie	M34	06-07		MST 298		260	MST 298		260
	400 Beverly Tourer ie	M34	08-09		* MST 298		260	MST 395		240
	400 MP3 ie, LT ie, RL	M59	07-		* MST 394		240	MST 395		240
	400 Xevo	M52	10-					MST 395		240
X8	400 ie	M52	06-08		* MST 298		260	MST 395		240
	500 MP3 EFI	M64	09-		* MST 394		240	MST 395		240
	500 MP3 LT Business/Sport ie	M64	11-		* MST 394		240	MST 395		240
	500 Beverly	M34	02-06		* MST 298		260	MST 395		240
	500 Beverly ie, Cruiser ie	M34	07-		* MST 298		260	MST 395		240
X9	500 SL	M27	00-02		* MST 298		260	MST 395		240
X9	500 Evolution, ABS	M27	03-06		MST 393		260	MST 395		240
X9	500 ie	M27	07		* MST 298		260	MST 395		240

Royal Enfield

	500 Electra	Bullet	05-11		MST 233		280			
	500 Clubman EFI	Bullet	09-		MST 233		280			
	500 Bullet Classic EFI	Bullet	09-		MST 233		280			
	500 Woodsman EFI	Bullet	10-		MST 233		280			
	500 Trails EFI	Bullet	09-		MST 233		280			



Option 1

Option 2



Option 1

Option 2

**Sachs**

50 Gipsy	FE053-DE	94-		MST 252	RAC		190			
50 Reggae		94-		MST 252	RAC		190			
50 Samba	F052-DE	92-		MST 252	RAC		190			
50 Splinter	FE053-DE	94-		MST 252	RAC		190			

Sinnis

50 Falcon	QM50QT-2T	08-		MST 250			155			
50 Ghost	WY50QT-39A	06-	Qingqi	MST 243	RAC		190			
50 Jet	QM50QT-6A	08-	Qingqi	MST 250			155			
50 Nitro 2T		09-	Qingqi	MST 256			180			
50 Pionier 2T		09-	Qingqi	MST 243	RAC		190			
50 Road Classic		08-	Qingqi	MST 250			155			
50 Strike 2T		09-	Qingqi	MST 256			180			
125 Nitro	WY125T-56A	09-	Qingqi	MST 256			180			
125 Pionier		09-	Qingqi	MST 243	RAC		190			

Suzuki

AP	50 S	CA1JA	94-		MST 263			180			
AY	50 Katana	AA	96-98		MST 263			180			
AY	50 WR Katana	AA	99-06		MST 263			180			
TR	50 street magic	AH	98-99		MST 263			180			
UF	50 Estilete	WVBA	00-01		MST 263			180			
UX	50 Zillion	AT	99-00		MST 263			180			
RM	65		03-07		MST 443 EC				MST 443 EC		
RM	80		90-01						MST 332		184
RM	85		02-04						MST 332		184
RM	85		05-		MST 318	EC	220		MST 313 RAC		200
UG	110 Hokuto	AT	98-		MST 263			180			
UH	125 Burgman	C8	14-		MST 437			240	MST 437		240
DR	125 SM	CS	08		MST 307	RAC	250		MST 341	RAC	220
RG	125 Gamma	NF13	93-		MSW 218			300			
RM	125	RF13A	88-98		MST 311	RAC	EC	250	MST 341	RAC	220
RM	125	RF13A	99-05		MST 311	RAC	EC	250	MST 342	RAC	240
RM	125		06-10		MST 311	RAC	EC	250	MST 371 RAC	EC	240
UH	200 Burgman	CD	07-		MST 437			240	MST 437		
AN	250 Skywave/Burgman	AN	03-08		MST 380			260			
DR	250	SJ45A	95-00		MST 311	RAC	EC	250	MST 341	RAC	220
DR-Z	250		01-07		MST 311	RAC	EC	250	MST 341	RAC	220
GW	250 Inazuma	DC	13-		MST 460			290	MST 386	RAC	260
GSF	250 Bandit	GJ74A/77A	90-99		MSW 219	RAC		310			
LT	250 Quad racer, Quad Sport	LTZ250	85-92		MST 402			160			
RGV	250	VJ21A	89-90	*	MSW 220	RAC		290			
RGV	250	VJ22B	91-95	*	MSW 218			300			
RM	250	RJ14A	88-98		MST 311	RAC	EC	250	MST 341	RAC	220
RM	250	RJ14A	99-05		MST 311	RAC	EC	250	MST 342	RAC	240
RM	250		06-10		MST 311	RAC	EC	250	MST 371 RAC	EC	240
RM-Z	250	RL51C	04-06		MST 307	RAC		250	MST 339	RAC	240
RM-Z	250	RL42A	07-		MST 304 RAC	EC		250	MST 305 RAC	EC	240
RMX	250	PJ11A	89-98		MST 311	RAC		250	MST 341	RAC	220
AN	400 Burgman	WVBW	03-06	*	MST 380			260			
AN	400 Burgman ABS, Z Burgman ABS	WVCG	07-	*	MST 380			260	MST 381		210
DR-Z	400	BE	00-03		MST 311	RAC	EC	250	MST 341	RAC	220
DR-Z	400	BF	04		MST 311	RAC	EC	250	MST 341	RAC	220
DR-Z	400	WVBC	05-08		MST 311	RAC	EC	250	MST 341	RAC	220
DR-Z	400 SM	WVB8	05-08					250	MST 371 RAC	EC	240
GSF	400 Bandit	GK75A	89-94		MSW 219	RAC		310	MST 364		250
GSF	400 Bandit	GK75B	91-95	DE market	* MSW 220	RAC		290	MST 364		250
GSXR	400	GK73A	88-90		* MSW 220	RAC		290			
GSXR	400	GK76A	90-95		* MSW 218			300			
LTZ	400 Quad Sport	LTZ400	02-		MST 402			160	MST 323		220
LTR	450	LTR450	06-		MST 411			160	MST 412		190
RM-Z	450	RL41C	05-		MST 304 RAC	EC		250	MST 305 RAC	EC	240



* 2 Scheiben erforderlich – 2 discs required
 EX starre Scheibenausführung – fixed disc

☐ linke Seite – left side
 ☐ rechte Seite – right side



Option 1

Option 2



Option 1

Option 2



Suzuki										
RMX	450 Z	PL41A	10-		MST 304 RAC	EC	250	MST 305 RAC	EC	240
GS	500 E	GM51B	89-00		MSW 219	RAC	310	MST 364		250
GS	500 E	WVBK	01-03		MSW 219	RAC	310	MST 364		250
GS	500 F	BK	04-06		MSW 219	RAC	310	MST 364		250
GSF	600 Bandit	GN77B	95-99	*	MSW 220	RAC	290	MST 251	RAC	240
GSF	600 Bandit	WVA8	00-04	*	MSW 220	RAC	290	MST 251	RAC	240
GSR	600	WVB9	06-10	*	MSW 259	RAC	310	MST 386	RAC	240
GSR	600 A ABS	WVB9	06-10	*	MSW 259	RAC	310	MST 386	RAC	240
GSX	600 F	GN72B	89-92		MSW 220	RAC	290			
GSX	600 F	GN72B	93-97		MSW 220	RAC	290	MST 364		250
GSX	600 F	WVAJ	98-02	*	MSW 220	RAC	290	MST 251	RAC	240
GSX	600 F	WVAJ	03-04	*	MSW 248	RAC	290	MST 251	RAC	240
GSXR	600	WVAD	97-00	*	MSW 223	RAC	320	MST 246	RAC	SL 220
GSXR	600	WVBG	01-03	*	MSW 223	RAC	320	MST 246	RAC	SL 220
GSXR	600	WVB2	04-05	*	MSW 241	RAC	300	MST 246	RAC	SL 220
GSXR	600	WVCE	06-07	*	MSW 255 RAC		310	MST 246	RAC	SL 220
GSXR	600	WVCV	08-10	*	MSW 266 RAC		310	MST 246	RAC	SL 220
GSXR	600	C3	11-		MSW 266 RAC		310	MST 246	RAC	SL 220
GSXR	600	C3	11-	Racing only	MSW 266 SP	RAC-SP	310	MST 246	RAC	SL 220
RF	600 R, RU	GN76B	93-96	*	MSW 220	RAC	290	MST 251	RAC	240
VS	600 Intruder	VN51B	95-97		MST 231		295			
AN	650 Burgman, Executive, ABS	WVBU	04-	*	MST 380		260			
DL	650 V-Strom	WVB1	04-07	*	MSW 250	RAC	310	MST 368		260
DL	650 V-Strom	WVB1	08-11	*	MSW 259	RAC	310	MST 368		260
DL	650 V-Strom ABS	WVB1	07-11	*	MSW 259	RAC	310	MST 368		260
DL	650 V-Strom ABS	C7	12-	*	MSW 259	RAC	310	MST 368		260
DR	650 R, RS, RSE,RSEU	SP43B	91-95		MST 230		300			
DR	650 R,RU	SP44B	92-96		MST 230		300			
DR	650 SE	SP46B	96-00		MST 315		290			
GSF	650 Bandit, S Bandit	WVB5	05-06	*	MSW 248	RAC	290	MST 251	RAC	240
GSF	650 A, SA, Bandit ABS	WVB5	06	*	MSW 260 RAC		290	MST 386	RAC	240
GSF	650 Bandit, S Bandit	WVCJ	07-08	*	MSW 259	RAC	310	MST 386	RAC	240
GSF	650 A, SA, Bandit ABS	WVCJ	07-08	*	MSW 259	RAC	310	MST 386	RAC	240
GSF	650 Bandit, S Bandit	WVCZ	09-12	*	MSW 259	RAC	310	MST 386	RAC	240
GSF	650 A, SA, Bandit ABS	WVCZ	09-12	*	MSW 259	RAC	310	MST 386	RAC	240
GSX	650 F, FA ABS	WVCJ	08-11	*	MSW 259	RAC	310	MST 386	RAC	240
GSX	650 F, FA ABS	WVCZ	12-	*	MSW 259	RAC	310	MST 386	RAC	240
SFV	650 Gladius, ABS	WVCX	09-	*	MSW 260 RAC		290	MST 386	RAC	240
SV	650 , S	WVAV	99-02	*	MSW 220	RAC	290	MST 251	RAC	240
SV	650 , S	WVBY	03-08	*	MSW 248	RAC	290	MST 246	RAC	220
SV	650 ABS, S ABS	WVBY	07-08	*	MSW 260 RAC		290	MST 386	RAC	240
XF	650 Freewind	WVAC	97-01	🏍️ FIX	MST 230		300			
LTA	700 King Quad	LTA 700	05-07		MST 414		200			
GSR	750 , ABS	C5	11-	*	MSW 259	RAC	310	MST 386	RAC	240
GSX	750	AE	98-02	*	MSW 218		300	MST 251	RAC	240
GSX	750 F	GR78A	89-97	*	MSW 220	RAC	290	MST 364		250
GSX	750 F	WVAK	98-02	*	MSW 220	RAC	290	MST 251	RAC	240
GSX	750 F	WVAK	03-06	*	MSW 248	RAC	290	MST 251	RAC	240
GSXR	750	GR77A/B	88-89	*	MSW 217	RAC	310	MST 251	RAC	240
GSXR	750	GR7AB	90-91	*	MSW 217	RAC	310	MST 251	RAC	240
GSXR	750	GR7BB	92-95	*	MSW 217	RAC	310	MST 251	RAC	240
GSXR	750	GR7DB	96-99	*	MSW 223	RAC	320	MST 246	RAC	SL 220
GSXR	750	WVBD	00-03	*	MSW 223	RAC	320	MST 246	RAC	SL 220
GSXR	750	WVB3	04-05	*	MSW 241	RAC	300	MST 246	RAC	SL 220
GSXR	750	WVCF	06-07	*	MSW 255 RAC		310	MST 246	RAC	SL 220
GSXR	750	WVCW	08-10	*	MSW 266 RAC		310	MST 246	RAC	SL 220
GSXR	750	C4	11-	*	MSW 266 RAC		310	MST 246	RAC	SL 220
GSXR	750	C4	11-	Racing only	MSW 266 SP	RAC-SP	310	MST 246	RAC	SL 220
LTA	750 King Quad	LTA750	05-		MST 414		200			
VS	750 Intruder GLF, GLP	VR51B	87-91		MST 231		295			
DR	800 S, SU	SR42B	90	🏍️ FIX	MST 230		300			
DR	800 S, SU	SR43B	91-99	🏍️ FIX	MST 230		300			
VL	800 Intruder Volusia	WVBM	01-06		MST 468		300			
C	800 Intruder, C Intruder	WVBM	07-		MST 468		300			
VS	800 GL Intruder	VS52B	92-00		MST 231		295			
VZ	800 Marauder	AF	97-03		MSW 218		300			



Option 1

Option 2



Option 1

Option 2

**Suzuki**

RF	900 R	GT73B	94-97	*	MSW 219	RAC	310	MST 251	RAC	240
DL	1000 V-Strom	WVBS	02-09	*	MSW 250	RAC	310	MST 368		260
DL	1000 V-Strom ABS	DD	14-	*	MSW 259	RAC	310	MST 368		260
GSXR	1000	WVBL	01-02	*	MSW 223	RAC	320	MST 246	RAC	SL 220
GSXR	1000	WVBZ	03-04	*	MSW 241	RAC	300	MST 246	RAC	SL 220
GSXR	1000	WVB6	05-06	*	MSW 255 RAC		310	MST 246	RAC	SL 220
GSXR	1000	WVCL	07-08	*	MSW 255 RAC		310	MST 246	RAC	SL 220
GSXR	1000	WVCY	09-	*	MSW 266 RAC		310	MST 246	RAC	SL 220
GSXR	1000	WVCY	09-	Racing only	MSW 266 SP	RAC-SP	310	MST 246	RAC	SL 220
GSXR	1000 ABS	DG	15-	*	MSW 266 RAC		310	MST 246	RAC	SL 220
GSXR	1000 ABS	DG	15-	Racing only	MSW 266 SP	RAC-SP	310	MST 246	RAC	SL 220
SV	1000 , S	WVBX	03-08	*	MSW 250	RAC	310	MST 246	RAC	SL 220
TL	1000 S	AG111	97-01	*	MSW 223	RAC	320	MST 246	RAC	SL 220
TL	1000 R	AM321	98-02	*	MSW 223	RAC	320	MST 246	RAC	SL 220
GSXR	1100	GV73C	89-92	*	MSW 217	RAC	310	MST 251	RAC	240
GSXR	1100 W	GU75C	93-97	*	MSW 217	RAC	310	MST 251	RAC	240
GSX	1200 FS	A3	99-00	*	MSW 219	RAC	310	MST 251	RAC	240
GSF	1200 Bandit, S Bandit	GV75A	95-00	*	MSW 219	RAC	310	MST 251	RAC	240
GSF	1200 Bandit, S Bandit	WVA9	01-05	*	MSW 219	RAC	310	MST 251	RAC	240
GSF	1200 Bandit, S Bandit	WVCB	06	*	MSW 259	RAC	310	MST 386	RAC	240
GSF	1200 A, SA, Bandit ABS	WVCB	06	*	MSW 259	RAC	310	MST 386	RAC	240
GSF	1250 A, SA, Bandit ABS	WVCH	07-	*	MSW 259	RAC	310	MST 386	RAC	240
GSX	1250 F, FA ABS	WVCH	10-	*	MSW 259	RAC	310	MST 386	RAC	240
GSX	1300 R Hayabusa	WVA1	99-07	*	MSW 223	RAC	320	MST 251	RAC	240
GSX	1300 R Hayabusa	WVCK	08-12	*	MSW 259	RAC	310	MST 343 RAC		260
GSX	1300 RA Hayabusa ABS	WVCK	13-	*	MSW 259	RAC	310	MST 343 RAC		260
GSX	1300 B-King, ABS	WVCR	08-12	*	MSW 259	RAC	310	MST 343 RAC		260
GSX	1400	WVBN	01-07	*	MSW 223	RAC	320			
VS	1400 Intruder	VX51L/LD	87-03		MST 231		295	MST 365		275
VZ	1500 M 1500 Intruder	WVCU	09-10	*	MSW 248	RAC	290			
VZ	1600 M 1600 Marauder	VNT60B	04-05		MSW 216	RAC	320			
VZ	1600 M 1600 Intruder	VNT60B	04		MSW 216	RAC	320			
VLR	1800 C 1800 R Intruder	WVCT	08-11	*	MSW 248	RAC	290			
VZR	1800 M 1800 R, R2 Intruder	WVCA	06-	*	MSW 255 RAC		310			

SYM

	50 Allo	AJ05W	11-		MST 243	RAC	190			
	50 City Hopper		96-06		MST 241		162			
	50 Fancy	F5L	98-		MST 236	RAC	190			
	50 Fiddle	AW05W	08-		MST 243	RAC	190			
	50 Fiddle II	AW12W	08-		MST 243	RAC	190			
	50 Jet	G5J	95-		MST 236	RAC	190			
	50 Mio	HU05W	05-		MST 241		162			
	50 Orbit, Orbit II	AV05W	08-		MST 243	RAC	190			
	50 Pure	F5B-2	98-		MST 236	RAC	190			
	50 Red Devil	G5J	97-		MST 236	RAC	190			
	50 Super Fancy	F5L	96-06		MST 241		162			
	50 Simply		07-		MST 243	RAC	190			
	100 Mio	HU10W	05-		MST 241		162			
	100 Super Fancy	F5L	96-		MST 241		162			
	100 Jet	G5J	95-		MST 236	RAC	190			
	100 Jet	G100P	99-		MST 236	RAC	190			
	125 Megalo	AK12W	00-		MST 241		162			
	125 Allo		11-		MST 243	RAC	190			
	125 Attila	H125D	99-00		MST 241		162			
	125 Fiddle		08-		MST 243	RAC	190			
	125 Megalo	AK12W	00-07		MST 241		162			
	125 Simply		07-		MST 243	RAC	190			
	125 SR		99-		MST 241		162			
	125 Super Duke	A125Q2-2	99-02		MST 241		162			
	150 Super Duke	A125Q2-2	99-02		MST 241		162			



* 2 Scheiben erforderlich – 2 discs required
 EX starre Scheibenausführung – fixed disc

☑ linke Seite – left side
 ☑ rechte Seite – right side



Option 1

Option 2



Option 1

Option 2

**TGB**

	50 Akros Tec	GH5	03-04		MST 243	RAC	190			
	50 City		07-		MST 243	RAC	190			
	50 Delivery/Express		04-		MST 243	RAC	190			
	50 High wheel	G15	02-03		MST 243	RAC	190			
	50 Trigger		02-03		MST 243	RAC	190			
	50 101 R	BH1	04-09		MST 243	RAC	190			
	50 202 Classic	BF8	03-09		MST 243	RAC	190			
	50 303 R Hawk/Laser	BR1	04-10		MST 243	RAC	190			
	50 303 Revolution/Meteorit		02-03		MST 243	RAC	190			
	50 409 Cruise		02-03		MST 243	RAC	190			
	125 303 Revolution		02-03		MST 243	RAC	190			
	125 409 Cruise		02-03		MST 243	RAC	190			

Triumph

TT	600	806AD	00-03	*	MSW 261 RAC		310	MST 245	RAC	SL	220	
	600 Speed Four	806LB	03-05	*	MSW 261 RAC		310	MST 245	RAC	SL	220	
	600 Daytona	806AD	03-04	*	MSW 261 RAC		310	MST 245	RAC	SL	220	
	650 Daytona	865LX	05	*	MSW 261 RAC		310	MST 245	RAC	SL	220	
	675 Daytona, Daytona R	D67LC	06-11	*	MSW 261 RAC		310	MST 245	RAC	SL	220	
	675 Daytona, Daytona R	H67	12	*	MSW 261 RAC		310	MST 245	RAC	SL	220	
	675 Daytona, ABS	H67	13-	*	MSW 287 RAC		310	MST 467 RAC			220	
	675 Daytona, ABS	H67	13-	Racing only	*	MSW 287 SP	RAC-SP	310	MST 467 RAC		220	
	675 Daytona R, ABS	H67	13-	*	MSW 287 RAC		310	MST 467 RAC			220	
	675 Daytona R, ABS	H67	13-	Racing only	*	MSW 287 SP	RAC-SP	310	MST 467 RAC		220	
	675 Street Triple, R	D67LD	07-12	*	MSW 261 RAC		310	MST 245	RAC	SL	220	
	675 Street Triple, ABS	L67LR	13-	*	MSW 287 RAC		310	MST 467 RAC			220	
	675 Street Triple R, ABS	L67LR	13-	*	MSW 287 RAC		310	MST 467 RAC			220	
	675 Street Triple RX ABS		15-	*	MSW 287 RAC		310	MST 467 RAC			220	
	800 Tiger XC	A08	11-	*	MSW 286		305	MST 434			255	
	800 Tiger XC ABS	A08	11-	*	MSW 286		305				255	
	900 Speed Triple	T509	97-98	*	MSW 251		320	MST 245	RAC	SL	220	
	955 Daytona	T595	97-01	*	MSW 251		320	MST 245	RAC	SL	220	
	955 Daytona	595N	02-06	*	MSW 279		320	MST 245	RAC	SL	220	
	955 Speed Triple	T509	99-01	*	MSW 251		320	MST 245	RAC	SL	220	
	955 Speed Triple	595N	02-04	*	MSW 279		320	MST 245	RAC	SL	220	
	955 Sprint RS	T695	99-05	*	MSW 251		320	MST 434			255	
	955 Sprint ST	T695	99-05	*	MSW 251		320	MST 434			255	
	1050 Speed Triple, Fgst. -333178	515NJ	05-07	Nissin	*	MSW 278		320	MST 436		220	
	1050 Speed Triple, Fgst. -461331	515NJ	08-10	Brembo	*	MSW 276		320	MST 436		220	
	1050 Speed Triple, Fgst. 461332-	515NV	11-	Brembo	*	MSW 276		320	MST 434		255	
	1050 Speed Triple ABS	515NV	11-	Brembo	*	MSW 276		320			255	
	1050 Speed Triple R	515NV	12-		*	MSW 276		320	MST 245	RAC	SL	220
	1050 Sprint GT	215ND	10-	ABS	*	MSW 276		320	MST 434		255	
	1050 Sprint ST	215NA	05-10	ABS	*	MSW 279		320	MST 434		255	
	1050 Tiger, Tiger SE	115NG	07-		*	MSW 278		320	MST 434		255	
	1050 Tiger Sport	115NG	14-		*	MSW 278		320	MST 434		255	
	1050 Tiger Sport ABS	115NG	14-		*	MSW 278		320			255	
	1200 Tiger Explorer, ABS	V13VG	12-		*	MSW 286		305	MST 462		282	
	1200 Trophy		13-		*	MSW 276		320	MST 462		282	
	2300 Rocket III		04-		*	MSW 279		320				

Vertemati

C	500 Cross	501	01-03					MST 321			220
E	500 Enduro	501	01-03					MST 321			220

Villa

AX	50		93-		MST 250		155				
GZ	50		93-		MST 250		155				

Voxan

	1000 Roadster	V2	01-	*	MSW 211	RAC	320	MST 247	RAC		245
	1000 Cafe racer	V2	00-	*	MSW 211	RAC	320	MST 247	RAC		245
	1000 Scrambler	SC	03-	*	MSW 211	RAC	320	MST 247	RAC		245
	1000 Street Scrambler	SS	03-	*	MSW 211	RAC	320	MST 247	RAC		245
	1000 Black Magic	BM	04-	*	MSW 211	RAC	320	MST 247	RAC		245



Option 1

Option 2



Option 1

Option 2



Yamaha

BW's	50		99-		MST 257		180					
EW	50 Slider	SA09	00-06		MST 236	RAC	190					
CS	50 Jog R/ Jog RR	SA22	01-		MST 236	RAC	190					
CW	50 Spy	4VA	95-99		MST 257		180					
CW	50 Bump	4VA	97-99		MST 257		180					
CW	50 NG BWs	4VA	95-98		MST 257		180					
CW	50 NG BWs	SA05	99-		MST 243	RAC	190					
CW	50 Booster Spirit	SA05	99-		MST 257		180					
CRZ	50	3WN	92-95		MST 250		155					
CV	50 Jog	3WG	91-		MST 250		155					
CV	50 Jog	SA22	02-		MST 250		155					
NS	50 R Aerox	SA42	13-		MST 243	RAC	190					
NS	50 R Aerox Naked	SA42	13-		MST 243	RAC	190					
TZR	50	RA03	97-00		MST 233		282					
YA	50 Axis	3UG	94-96		MST 250		155					
YE	50 Zest	4FW	93-95		MST 250		155					
YM	50 Fizz	4RC	94-		MST 250		155					
YM	50 Breeze	4RC	94-98		MST 250		155					
YN	50 Neo's	5AD	97-01		MST 236	RAC	190					
YN	50 Neo's	SA15	02-03		MST 236	RAC	190					
YN	50 Neo's	SA21	04-06		MST 236	RAC	190					
YN	50 Neo's 2T	SA34	07-		MST 236	RAC	190					
YN	50 Neo's 4T	SA40	07-		MST 236	RAC	190					
YQ	50 Aerox	5BR	97-01		MST 243	RAC	190	MST 243	RAC		190	
YQ	50 Aerox	SA14	02-12		MST 243	RAC	190	MST 243	RAC		190	
YQ	50 R Aerox	SA14	02-12		MST 243	RAC	190	MST 243	RAC		190	
YZ	80	4GT/4LB	93-97		MST 318		EC	220	MST 348	EC	190	
YZ	80	CB01	98-01		MST 318		EC	220	MST 348	EC	190	
YZ	80 LW	CB02	98-01	16"	MST 318		EC	220	MST 348	EC	190	
YZ	85 LW	CB05	02-03	16"	MST 318		EC	220	MST 348	EC	190	
YZ	85 SW	CB04	02-03	14"	MST 318		EC	220	MST 348	EC	190	
YZ	85 LW	CB08/10	04-	16"	MST 318		EC	220	MST 348	EC	190	
YZ	85 SW	CB07/09	04-	14"	MST 318		EC	220	MST 348	EC	190	
YN	100 Neos	SA15	00-03		MST 236	RAC	190					
YQ	100 Aerox	SB05	00-		MST 243	RAC	190	MST 243	RAC		190	
DT	125 R, RH, RN	4BL	88-98		MST 355		230	MST 346			220	
DT	125 RH, RN	DE03	99-03		MST 355		230	MST 346			220	
DT	125 RE	DE06	04-06		MST 355		230	MST 346			220	
DT	125 X	DE06	04-06		MSW 224		298	MST 346			220	
HW	125 Xenter	SE59	12-		MSW 269							
SR	125	10F	95-03		MST 248		267					
TDR	125 Japan		89-03		MST 234		282	MST 346			220	
TDR	125 Italy	4GW	89-03		MSW 211	RAC	320	MST 346			220	
TZ	125	4JT	94-97		MSW 221	RAC	300					
VP	125 X-City	SE43	08-					MST 382			240	
WR	125		90-92		MST 355		230	MST 346			220	
WR	125		93-97		MST 316		245	MST 346			220	
WR	125		98-00		MST 316		245	MST 347			240	
WR	125		01		MST 311	RAC	EC	250	MST 347		240	
WR	125		02-07		MST 311	RAC	EC	250	MST 350	RAC	EC	245
WR	125 X	DE07	09-		MSW 224	RAC	300					
XQ	125 Maxster	SE05	01-03		MST 370		245					
XV	125 Virago	5AJ	97-01		MST 233		282					
XVS	125 Drag Star	VE01	00-04		MST 233		282					
XN	125 Teos	SE04	00-03		MST 259		220					
YP	125 D Majesty	SE02	98-		MST 259		220					
YP	125 D Majesty	SE06	01-09		MST 259		220					
YP	125 R X-Max	SE32	06-09		MSW 269		267	MST 382			240	
YP	125 R X-Max	SE54	10-		MSW 269		267	MST 382			240	
YP	125 RA X-Max ABS	SE54	10-		MSW 269		267	MST 274			245	
YBR	125 ED	RE03	05		MST 268 RAC		245					
YBR	125 ED	RE04	06		MST 268 RAC		245					



* 2 Scheiben erforderlich – 2 discs required
 EX starre Scheibenausführung – fixed disc

☐ linke Seite – left side
 ☐ rechte Seite – right side



Option 1

Option 2



Option 1

Option 2



Yamaha										
YBR	125 ED	RE05	07-		MST 268 RAC			245		
YBR	125	RE10	09-		MST 268 RAC			245		
YZ	125	1LX	86		MST 355			230	MST 346	220
YZ	125	2HG	87		MST 355			230	MST 346	220
YZ	125	2VN	88		MST 355			230	MST 346	220
YZ	125	3JD	89		MST 355			230	MST 346	220
YZ	125	3SR	90-91						MST 346	220
YZ	125	4DB	92		MST 316			245	MST 346	220
YZ	125	4EX	93		MST 316			245	MST 346	220
YZ	125	4JY	94		MST 316			245	MST 346	220
YZ	125	4PE	95		MST 316			245	MST 346	220
YZ	125	4SS	96-97		MST 316			245	MST 346	220
YZ	125	4XM	98-99		MST 316			245	MST 347	240
YZ	125	CE05	00		MST 316			250	MST 347	240
YZ	125	CE08	01		MST 311	RAC	EC	250	MST 347	240
YZ	125 /LC	CE09	02-		MST 311	RAC	EC	250	MST 350	RAC EC 245
YZF-R	125	RE06	08-13		MST 383			292	MST 389	
XQ	150 Maxster	SG06	01-03		MST 370			245	MST 259	220
YP	150 Majesty	SG08	98-		MST 259			220		
YP	180 Majesty	SG12	03-		MST 259			220		
WR	200	4BF	98-00		MST 316			245	MST 347	240
YFS	200 Blaster	YFS200	88-05						MST 407	220
YFS	200 Blaster	YFS200	06-		MST 405			161	MST 407	220
TDR	250	3CK	89-90		MSW 211	RAC		320		
TT	250 R	4MR	93-03						MST 346	220
TZ	250	4TW	97		MSW 221	RAC		300		
VP	250 X-City	SG19	08-		MST 457			270	MST 382	240
WR	250	3RB	90-91	US market					MST 346	220
WR	250	4DC	92-93	US market	MST 316			245	MST 346	220
WR	250	4JW	94-97		MST 316			245	MST 346	220
WR	250	4SR	98-00		MST 316			245	MST 347	240
WR	250	CG	01		MST 311	RAC	EC	250	MST 347	240
WR	250	CG	02-07		MST 311	RAC	EC	250	MST 350	RAC EC 245
WR	250 X	DG20	08-		MSW 224	RAC		300	MST 388 RAC	230
WR	250 F	CG	01		MST 311	RAC	EC	250	MST 347	240
WR	250 F	CG	02-		MST 311	RAC	EC	250	MST 350	RAC EC 245
XV	250 Virago	3 LW	95-00		MST 233			282		
XVS	250 Dragstar	VG03	01-04		MST 233			282		
YFM	250 X	YFM250	01-04		MST 405			161		
YFM	250 Bruin	YFM250	05-		MST 405			161		
YFM	250 Big Bear	YFM250	07-		MST 405			161		
YFM	250 Raptor	YFM250	08-		MST 405			161		
YP	250 Majesty	4UC	96-		MST 247			245		
YP	250	SG02	96-98		MST 247			245		
YP	250 Majesty de Luxe	SG04	98-		MST 247			245		
YP	250 Skyliner, ABS	5GM	00-		MST 247			245		
YP	250 R X-Max	SG16	05-09		MSW 269			267	MST 382	240
YP	250 R X-Max	SG22	10-		MSW 269			267	MST 382	240
YP	250 RA X-Max ABS	SG22	10-		MSW 269			267	MST 276	245
YZ	250	2VM	88-89		MST 355			230	MST 346	220
YZ	250	3SP/3XK	90-91						MST 346	220
YZ	250	4DA	92		MST 316			245	MST 346	220
YZ	250	4EW	93		MST 316			245	MST 346	220
YZ	250	4JX	94		MST 316			245	MST 346	220
YZ	250	4MX	95		MST 316			245	MST 346	220
YZ	250	4SR	96-97		MST 316			245	MST 346	220
YZ	250	4XL	98-00		MST 316			245	MST 347	240
YZ	250	CG	01		MST 311	RAC	EC	250	MST 347	240
YZ	250 /LC	CG	02-		MST 311	RAC	EC	250	MST 350	RAC EC 245
YZ	250 F	CG	01		MST 311	RAC	EC	250	MST 347	240
YZ	250 F	CG	02-		MST 311	RAC	EC	250	MST 350	RAC EC 245
XC	300 Versity		03-06						MST 382	240
YZF	300 R3		15-		MSW 246	RAC		298	MST 285 RAC	220
RD	350 LC	31K	85-90	*	MST 248	RAC		267	MST 248	RAC 267
RD	350 LC	1WW	86-90	*	MST 248	RAC		267	MST 248	RAC 267
RD	350 LC	1WX	86-90	*	MST 248	RAC		267	MST 248	RAC 267



Yamaha											
YFM	350 Warrior	YFM350	92-04		MST 405			161	MST 406		245
YFM	350 Wolverine	YFM350	95-06						MST 407		220
YFM	350 Raptor	YFM350	04-		MST 405			161			
YZF	350 Banshee	YFZ350	87-06		MST 405			161	MST 407		220
YZ	360		89-93						MST 346		220
FZR	400 R	4DX	90-		MSW 221	RAC		300			
SR	400	RH05	14-		MSW 224	RAC		300			
SRX	400		91-96		MSW 211	RAC		320	MST 247	RAC	245
WR	400 4-T	CH	98		MST 316			245	MST 346		220
WR	400 4-T	CH	99-00		MST 316			245	MST 347		240
WR	400	CH	01		MST 311	RAC	EC	250	MST 347		240
XJR	400 R	4HM	97-02	*	MSW 221	RAC		300	MST 247	RAC	245
XVS	400		96-		MSW 235			298			
YFM	400 Grizzly	YFM400	07		MST 405			161			
YP	400 Majesty	SH02	05-06		MSW 269			267			
YP	400 Majesty, ABS	SH05	07-		MSW 269			267			
YP	400 X-Max DNA ABS		13-		MSW 269			267			
YZ	400 F	CH	98		MST 316			245	MST 346		220
YZ	400 F	CH	99		MST 316			245	MST 347		240
WR	426 F	CJ	01		MST 311	RAC	EC	250	MST 347		240
WR	426 F	CJ	02		MST 311	RAC	EC	250	MST 350	RAC	245
YZ	426 F	CJ	00		MST 316			245	MST 347		240
YZ	426 F	CJ	01		MST 311	RAC	EC	250	MST 347		240
YZ	426 F	CJ	02		MST 311	RAC	EC	250	MST 350	RAC	245
WR	450 F	CJ	03-		MST 311	RAC	EC	250	MST 350	RAC	245
YFZ	450	AJ11	04-05		MST 405			161			
YFZ	450	YFZ450	06-10		MST 405			161	MST 410		200
YZ	450 F	CJ	03-		MST 311	RAC	EC	250	MST 350	RAC	245
YZ	490	2HJ	85-90		MST 355			230	MST 346		220
RD	500 LC,YPVS	47X	84-88		MST 248	RAC		267			
RD	500 LC	1GE	85		MST 248	RAC		267	MST 247	RAC	267
WR	500	4AA	92-93	US market	MST 355			230	MST 346		220
XP	500 T-Max	SJ01	00-04		MST 234			282	MST 248	RAC	267
XP	500 T-Max	SJ03	05-06		MSW 269			282	MST 248	RAC	267
XP	500 T-Max	SJ05	07		MSW 269			267	MST 248	RAC	267
XP	500 T-Max, ABS	SJ06	08-12		MSW 268			267	MST 248	RAC	267
XP	530 A T-Max ABS	SJ09	12-		MSW 269			267	MST 469		282
XP	530 T-Max Black Max	SJ09	13-		MSW 269			267	MST 469		282
XV	535 Virago	3BR/2YL	95-		MSW 235			298			
XV	535 Virago	3BR/2YL	95-		MSW 224 RAC			298			
XV	535 Virago	VJ01	99-03		MSW 235			298			
XV	535 Virago	VJ01	99-03		MSW 224 RAC			298			
FZR	600	3RG/3RH	89	*	MSW 221	RAC		300	MST 247	RAC	245
FZR	600	3HE	89-94	*	MSW 221	RAC		300	MST 247	RAC	245
FZR	600	4JH/4MH	95-96	*	MSW 221	RAC		300	MST 247	RAC	245
FZS	600 Fazer	RJ02	98-03	*	MSW 221	RAC		300	MST 247	RAC	245
FZ6	600 N	RJ07	04-06	*	MSW 246	RAC		298	MST 374	RAC	245
FZ6	600 N	RJ14	07	*	MSW 246	RAC		298	MST 374	RAC	245
FZ6	600 NA ABS	RJ14	07	*	MSW 246	RAC		298	MST 374	RAC	245
FZ6	600 S Fazer	RJ07	04-06	*	MSW 246	RAC		298	MST 374	RAC	245
FZ6	600 S Fazer	RJ14	07-08	*	MSW 246	RAC		298	MST 374	RAC	245
FZ6	600 SA Fazer ABS	RJ07	06	*	MSW 246	RAC		298	MST 374	RAC	245
FZ6	600 SA Fazer ABS	RJ14	07-08	*	MSW 246	RAC		298	MST 374	RAC	245
FZ6-S2	600 N	RJ14	07-09	*	MSW 246	RAC		298	MST 374	RAC	245
FZ6-S2	600 NA ABS	RJ14	07-10	*	MSW 246	RAC		298	MST 374	RAC	245
FZ6-S2	600 S Fazer	RJ14	07-09	*	MSW 246	RAC		298	MST 374	RAC	245
FZ6-S2	600 SA Fazer ABS	RJ14	07-10	*	MSW 246	RAC		298	MST 374	RAC	245
SRX	600	1XL/1XM	85-89		MST 248			267	MST 247		245
SRX	600	3SX	90-		MSW 211			320	MST 247		245
TT	600 R	4LW	84-92		MST 355			230			
TT	600 S	4LW/4GV/5CH	93-03		MST 317			267	MST 346		220
XJ	600 H, N	51J	83-91	*	MST 248	RAC		267	MST 248	RAC	267
XJ	600 H, N	3KM/3KN	91	*	MST 248	RAC		267	MST 248	RAC	267

	* 2 Scheiben erforderlich – 2 discs required		linke Seite – left side
	starre Scheibenausführung – fixed disc		rechte Seite – right side



Option 1

Option 2



Option 1

Option 2



Yamaha

XJ	600 N	4BRA	92-		MST 249		320	MST 247	RAC	245
XJ	600 N	4BRB	92-		MST 249		320	MST 247	RAC	245
XJ	600 N	4LX	94-97		MST 249		320	MST 247	RAC	245
XJ	600 N	4BR	92-97		MST 249		320	MST 247	RAC	245
XJ	600 S Diversion	4BR	92-97		MST 249		320	MST 247	RAC	245
XJ	600 S Diversion	4LX	94-97		MST 249		320	MST 247	RAC	245
XJ	600 S Diversion	RJ01	98-03	*	MSW 235		298	MST 247	RAC	245
XJ	600 S Diversion	RJ01	98-03	*	MSW 224 RAC		298	MST 247	RAC	245
XJ6	600 N	RJ19	09-12	*	MSW 246	RAC	298	MST 280		245
XJ6	600 NA ABS	RJ19	09-12	*	MSW 246	RAC	298	MST 280		245
XJ6	600 N	RJ22	13-	*	MSW 246	RAC	298	MST 280		245
XJ6	600 NA ABS	RJ22	13-	*	MSW 246	RAC	298	MST 280		245
XJ6	600 S Diversion	RJ19	09-12	*	MSW 246	RAC	298	MST 280		245
XJ6	600 SA Diversion ABS	RJ19	09-12	*	MSW 246	RAC	298	MST 280		245
XJ6	600 S Diversion	RJ22	13-	*	MSW 246	RAC	298	MST 280		245
XJ6	600 SA Diversion ABS	RJ22	13-	*	MSW 246	RAC	298	MST 280		245
XJ6	600 F Diversion	RJ19	10-12	*	MSW 246	RAC	298	MST 280		245
XJ6	600 FA Diversion ABS	RJ19	10-12	*	MSW 246	RAC	298	MST 280		245
XJ6	600 F Diversion	RJ22	13-	*	MSW 246	RAC	298	MST 280		245
XJ6	600 FA Diversion ABS	RJ22	13-	*	MSW 246	RAC	298	MST 280		245
XJ6	600 SP ABS	RJ22	13-	*	MSW 246	RAC	298	MST 280		245
XT	600 H, N	43F	84-87		MST 232		267			
XT	600 H, N	49H	84-87		MST 232		267			
XT	600 H, N	2KF/2NF	87-90		MST 232		267	MST 349		220
XT	600 Z Tenere	34L	83-84		MST 232		267			
XT	600 Z Tenere	55W	85		MST 232		267			
XT	600 Z Tenere	1VJ	86-87		MST 232		267			
XT	600 Z Tenere	3AJ	88-91		MST 232		267	MST 349		220
XT	600 , E	3TB	90-94		MST 232		267			
XT	600 , E	3UW	90-94		MST 232		267			
XT	600 , E	3TB	95-97		MST 234		282			
XT	600 , E	3UW	95-97		MST 234		282			
XT	600 , E	DJ02	98-03		MST 234		282			
YZF	600 R6	RJ03	99-02	*	MSW 224	RAC	300	MST 363		220
YZF	600 R6	RJ05	03-04	*	MSW 246	RAC	298	MST 362	RAC	SL 220
YZF	600 R6	RJ09	05-06	*	MSW 242	RAC	310	MST 362	RAC	SL 220
YZF	600 R6	RJ11	06	*	MSW 242	RAC	310	MST 362	RAC	SL 220
YZF	600 R6	RJ15	07-	*	MSW 242	RAC	310	MST 362	RAC	SL 220
YZF	600 R6	RJ15	07-	Racing only	* MSW 242 SP	RAC-SP	310	MST 362	RAC	SL 220
YZF	600 R Thundercat	4TV	96-03	*	MSW 224	RAC	300	MST 247	RAC	245
XVS	650 Drag Star	4VR/XR	97-04		MSW 235		298			
XVS	650 Drag Star	4VR/XR	97-04		MSW 224 RAC		298			
XVS	650 Drag Star classic	VM02	98-00		MSW 235		298			
XVS	650 Drag Star classic	VM02	98-00		MSW 224 RAC		298			
XVS	650 Drag Star classic	VM03	01-03		MSW 235		298			
XVS	650 Drag Star classic	VM03	01-03		MSW 224 RAC		298			
XVS	650 Drag Star classic	VM04	04-07		MSW 235		298			
XVS	650 Drag Star classic	VM04	04-07		MSW 224 RAC		298			
SZR	660	4SU	96-97		MSW 211	RAC	320			
MT-03	660	RM02	06-13	*	MSW 246	RAC	298	MST 374	RAC	245
XT	660 R	DM01	04-		MSW 224	RAC	298	MST 247	RAC	245
XT	660 X	DM01	04-		MSW 271		320	MST 247	RAC	245
XT	660 X Tenere	DM01	08-		MSW 224	RAC	298	MST 247	RAC	245
XT	660 Z, ZA Ténére	DM02/04	08-	*	MSW 224	RAC	298	MST 247	RAC	245
XTZ	660 Z, Tenere	3YF/4MD	91-99		MST 234		282	MST 349		220
YFM	660 Raptor	AM01	01-05		MST 405		161	MST 407		220
MT-07	700	RM04	14-	*	MSW 202 RAC		298	MST 277 RAC		245
YFM	700 Raptor	AM07	06-		MST 405		161	MST 410		200
YFM	700 Grizzly	YFM700	07-		MST 416		220	MST 417		205
FZ	750 Genesis	1FN	85	*	MST 248	RAC	267	MST 248	RAC	267
FZ	750 Genesis	2KK	86-88	*	MST 248	RAC	267	MST 248	RAC	267
FZ	750 Genesis	3KT/2KK	89-92	*	MSW 221	RAC	300	MST 248	RAC	267
FZX	750 Fazer	2JE	87-90	*	MST 248		267	MST 248	RAC	267
MT-09	850 , ABS	RN29	13-	*	MSW 246	RAC	300	MST 277 RAC		245
XTZ	750 H, N	3LD/3WN	89-99	*	MST 369		240	MST 369		240
XV	750 Virago	4FY	-93		MST 248	RAC	267			



Option 1

Option 2



Option 1

Option 2



Yamaha

XV	750 Virago	4PW	94-97		MST 233		282			
YZF	750 R, SP	4HN/4HT	93-97	*	MSW 222		320	MST 247	RAC	245
YZF	750 R 7	RM01	99-	*	MSW 262 RAC		320	MST 247	RAC	245
FZ8	800 S Fazer	RN25	10-	*	MSW 242	RAC	310	MST 423		267
FZ8	800 SA Fazer ABS	RN25	10-	*	MSW 242	RAC	310	MST 423		267
FZ8	800 N	RN25	10-	*	MSW 242	RAC	310	MST 423		267
FZ8	800 NA ABS	RN25	10-	*	MSW 242	RAC	310	MST 423		267
TDM	850	3VD/4TX	91-01	*	MSW 221	RAC	300	MST 247	RAC	245
TRX	850	4UN	96-00	*	MSW 221	RAC	300	MST 247	RAC	245
TDM	900	RN08	02-03	*	MSW 224	RAC	300	MST 247	RAC	245
TDM	900 , A ABS	RN11	04-06	*	MSW 224	RAC	300	MST 247	RAC	245
TDM	900 A ABS	RN18	07-10	*	MSW 224	RAC	300	MST 247	RAC	245
TDM	900 A ABS	RN18	11-	*	MSW 224	RAC	300	MST 248	RAC	267
XJ	900	31A	83-84	*	MST 248	RAC	267	MST 248	RAC	267
XJ	900 F	58L/4BB	85-94	*	MST 248	RAC	267	MST 248	RAC	267
XJ	900 S Diversion	4KM	94-	*	MST 264		320	MST 248	RAC	267
XV	950 ABS, R ABS	VN03	14-		MSW 224	RAC	300			
XVS	950 A Midnight Star	VN02	09-		MSW 262 RAC		320	MST 284 RAC		298
FZR	1000 Genesis	2LA	87-88	*	MSW 211	RAC	320	MST 248	RAC	267
FZR	1000 EXUP	3LE	89-90	*	MSW 211	RAC	320	MST 248	RAC	267
FZR	1000 EXUP	3LE	91-93	*	MSW 211	RAC	320	MST 248	RAC	267
FZR	1000 EXUP	3LE	94-95	*	MSW 222		320	MST 248	RAC	267
FZS	1000 Fazer	RN06	01-04	*	MSW 224	RAC	300	MST 248	RAC	267
FZS	1000 Fazer	RN14	05	*	MSW 224	RAC	300	MST 248	RAC	267
FZ1	1000 N	RN16	06-	*	MSW 247	RAC	320	MST 374	RAC	245
FZ1	1000 NA ABS	RN16	08-	*	MSW 247	RAC	320	MST 374	RAC	245
FZ1	1000 S Fazer	RN16	06-	*	MSW 247	RAC	320	MST 374	RAC	245
FZ1	1000 SA Fazer ABS	RN16	09-	*	MSW 247	RAC	320	MST 374	RAC	245
GTS	1000	4BH	93-					MST 233		282
YZF	1000 R1	RN01	98-99	*	MSW 224	RAC	300	MST 247	RAC	245
YZF	1000 R1	RN04	00-01	*	MSW 224	RAC	300	MST 247	RAC	
YZF	1000 R1	RN09	02-03	*	MSW 224	RAC	300	MST 363		220
YZF	1000 R1	RN12	04-06	*	MSW 247	RAC	320	MST 362	RAC	SL 220
YZF	1000 R1	RN19	07-08	*	MSW 242	RAC	310	MST 362	RAC	SL 220
YZF	1000 R1	RN22	09-11	*	MSW 242	RAC	310	MST 362	RAC	SL 220
YZF	1000 R1, TCS	RN22	12-14	*	MSW 209 RAC		310	MST 362	RAC	SL 220
YZF	1000 R1 ABS		15-	*	MSW 204 RAC		320	MST 362	RAC	SL 220
YZF	1000 R1M ABS		15-	*	MSW 204 RAC		320	MST 362	RAC	SL 220
YZF	1000 R1 ABS, R1M ABS		15-	Racing only	MSW 204 SP	RAC-SP	320	MST 362	RAC	SL 220
YZF	1000 Thunderace	4VD	96-02	*	MSW 224	RAC	300	MST 247	RAC	245
BT	1100 Bulldog	RP05	02-06	*	MSW 224	RAC	300	MST 248	RAC	267
FJ	1100	47E	84-85	*	MST 233		282	MST 233		282
XV	1100 Virago	3LP	89-93	*	MST 248	RAC	267			
XV	1100 Virago	3LP	94-99	*	MST 233		282			
XVS	1100 Drag Star	VP05	99-04	*	MSW 235		298	MST 233		282
XVS	1100 Drag Star	VP05	99-04	*	MSW 224 RAC		298	MST 233		282
XVS	1100 Drag Star classic	VP05	00-	*	MSW 235		298	MST 233		282
XVS	1100 Drag Star classic	VP05	00-	*	MSW 224 RAC		298	MST 233		282
XVS	1100 Drag Star classic	VP16	03-	*	MSW 235		298	MST 233		282
XVS	1100 Drag Star classic	VP16	03-	*	MSW 224 RAC		298	MST 233		282
FJ	1200	1XJ	86-87		MST 233		282	MST 233		282
FJ	1200	3CW	88-89	*	MSW 221	RAC	300	MST 233		282
FJ	1200	3CX/3GP	90-	*	MSW 221	RAC	300	MST 233		282
FJ	1200	3YA / 3XW	91-96	*	MSW 221	RAC	300	MST 233		282
FJ	1200 ABS	3YA	91-96					MST 233		282
VMX	1200 V-max	1FK	86-92	*	MST 233		282	MST 233		282
VMX	1200 V-max	1JH	86-92	*	MST 233		282	MST 233		282
VMX	1200 V-max	1GR	85-92	*	MST 233		282	MST 233		282
VMX	1200 V-max	2LT	86-92	*	MST 233		282	MST 233		282
VMX	1200 V-max	3LR	89-	*	MST 233		282	MST 233		282
VMX	1200 V-max	3JP	89-	*	MST 233		282	MST 233		282
VMX	1200 V-max	3UF	91-	*	MST 233		282	MST 233		282
VMX	1200 V-max	3WF	93-94	*	MST 233		282	MST 233		282



* 2 Scheiben erforderlich – 2 discs required
 EX starre Scheibenausführung – fixed disc

☑ linke Seite – left side
 ☑ rechte Seite – right side



Option 1

Option 2



Option 1

Option 2



Yamaha

VMX	1200 V-Max	3WE	95-03	*	MSW 224	RAC	300	MST 233		282
VMX	1200 V-Max	2EN	95-03	*	MSW 224	RAC	300	MST 233		282
XJR	1200	4PU	96-98	*	MSW 211	RAC	320	MST 248		267
XT	1200 Z Super Ténéré ABS	DP01	10-	*	MSW 242	RAC	310	MST 432		282
XVZ	1200 12 T,TD	47G	84-87	*	MSW 235		298			
XVZ	1200 12 T,TD	47G	84-87	*	MSW 224	RAC	298			
XVZ	1200 Venture Royal	47G	84-90	*	MST 233		282	MST 233		282
FJR	1300	RP04	01-02	*	MSW 224	RAC	300	MST 233		282
FJR	1300 , ABS	RP08	03-05	*	MSW 262 RAC		320	MST 233		282
FJR	1300 , ABS	RP11	03-05	*	MSW 262 RAC		320	MST 233		282
FJR	1300 A, AS, ABS	RP13	06-	*	MSW 262 RAC		320	MST 233		282
XJR	1300	5E1A	99- Italy	*	MSW 211	RAC	320			
XJR	1300	RP02	99-01	*	MSW 224	RAC	300	MST 248	RAC	267
XJR	1300	RP06	02-03	*	MSW 224	RAC	300	MST 248	RAC	267
XJR	1300	RP10	04-06	*	MSW 224	RAC	300	MST 248	RAC	267
XJR	1300	RP19	07-	*	MSW 224	RAC	300	MST 248	RAC	267
XVS	1300 Custom	VP36	14-	*	MSW 247	RAC	320	MST 284 RAC		298
XVS	1300 A Midnight Star	VP2	07-	*	MSW 224	RAC	300	MST 284 RAC		298
XVZ	1300 Venture Royal	3JS	88-93	*	MST 233		282			
XVZ	1300 Royal Star	4YP	96-00	*	MSW 235		298	MST 249		320
XVZ	1300 Royal Star	4YP	96-00	*	MSW 224 RAC		298	MST 249		320
XVZ	1300 A	4YP	97-99	*	MST 233		282			
XVZ	1300 13 TF Wild Star	VP09	99-	*	MSW 235		298	MST 249		320
XVZ	1300 13 TF Wild Star	VP09	99-	*	MSW 224 RAC		298	MST 249		320
XVZ	1600 Wild Star	VP08	99-04	*	MSW 235		298			
XVZ	1600 Wild Star	VP08	99-04	*	MSW 224 RAC		298			
MT-01	1670	RP12	05-06	*	MSW 262 RAC		320	MST 248	RAC	267
MT-01	1670	RP18	07-09	*	MSW 273 RAC		310	MST 248	RAC	267
XV-Y	1700 V-max ABS	RP21	09-	*	MSW 247	RAC	320	MST 433 RAC		298
XV	1700 Road Star Warrior	VP14	03-	*	MSW 224	RAC	300	MST 233		282
XV	1900 A Midnight Star	VP23	06-12	*	MSW 224	RAC	300			

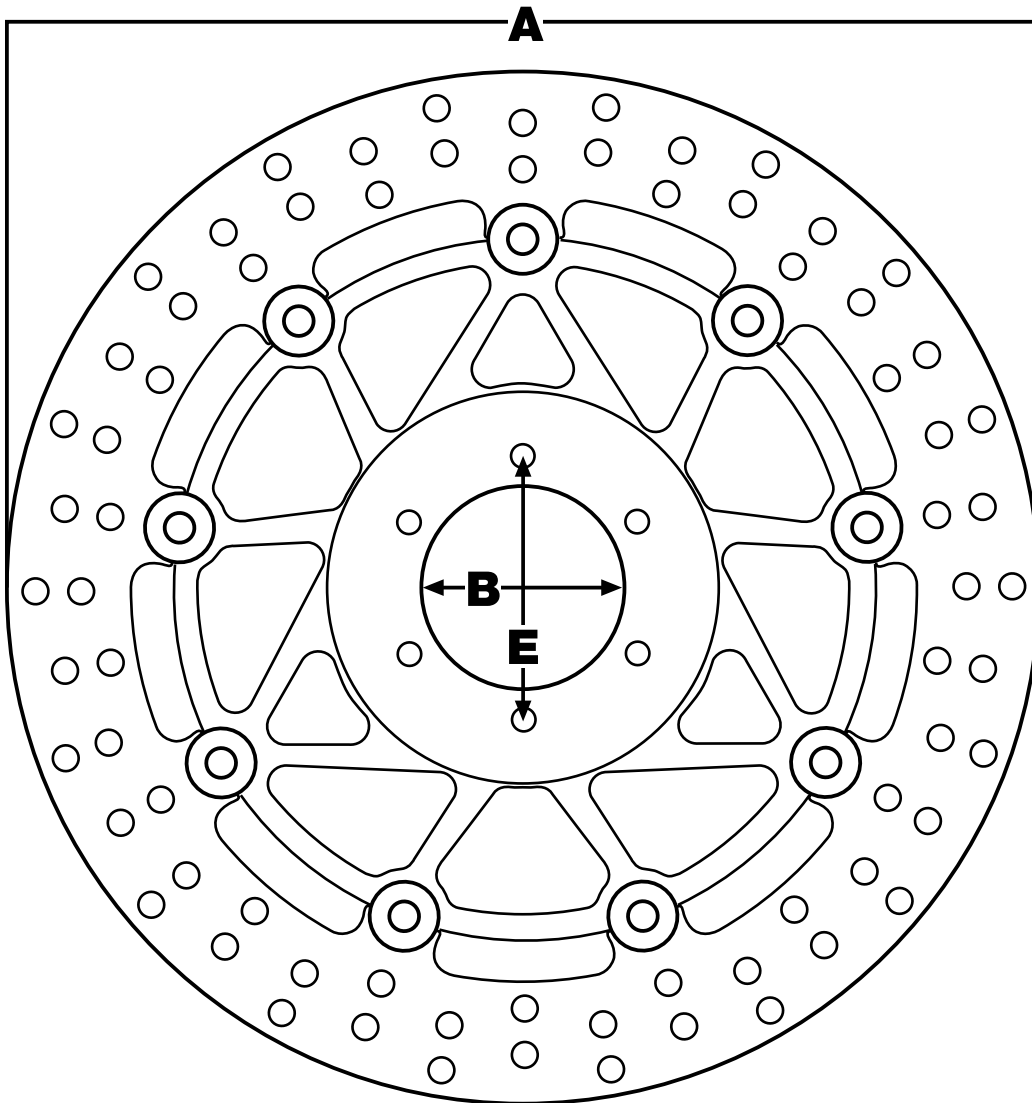
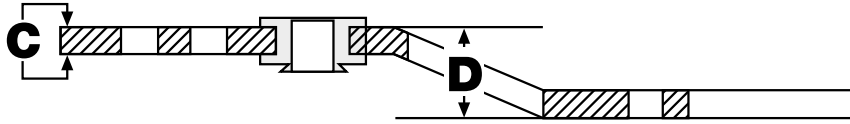



MST201

A	B	C	D	E
256	144	4		166

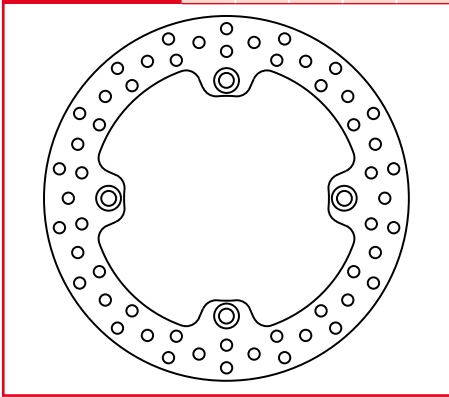

MST202

A	B	C	D	E
276	144	5		166

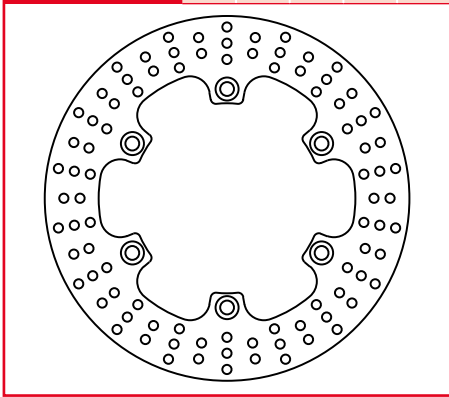

MST203

A	B	C	D	E
296	144	5		166

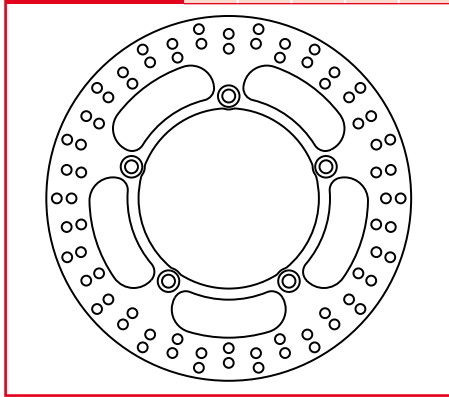

MST204

A	B	C	D	E
276	144	4		166

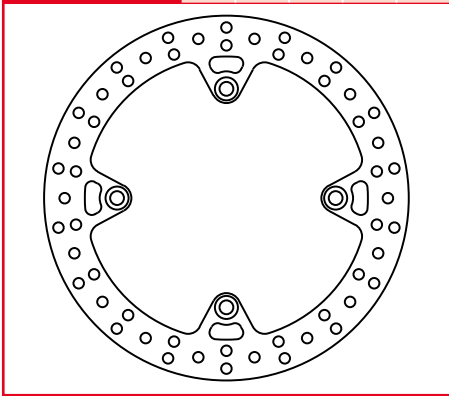

MST205

A	B	C	D	E
276	144	5		166

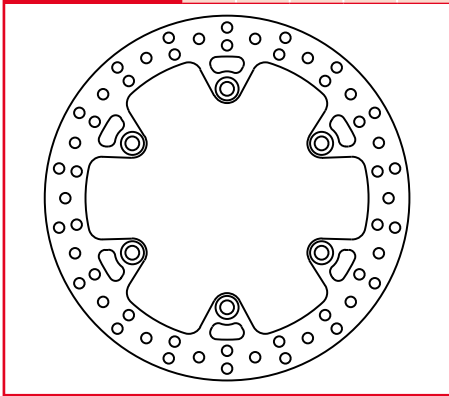

MST206

A	B	C	D	E
296	144	5		166

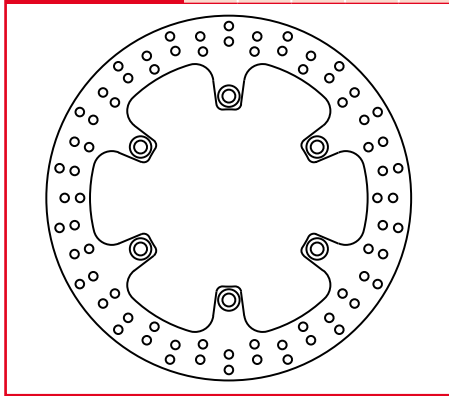

MST206RAC

A	B	C	D	E
296	144	5		166

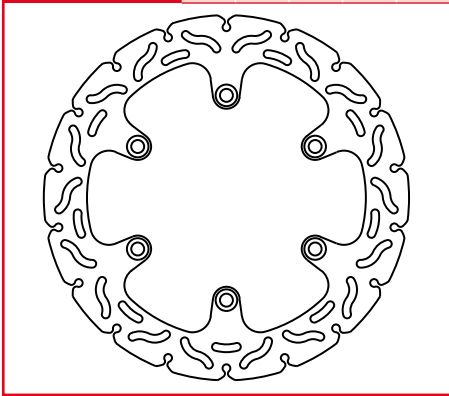

MST207

A	B	C	D	E
318	144	5		166

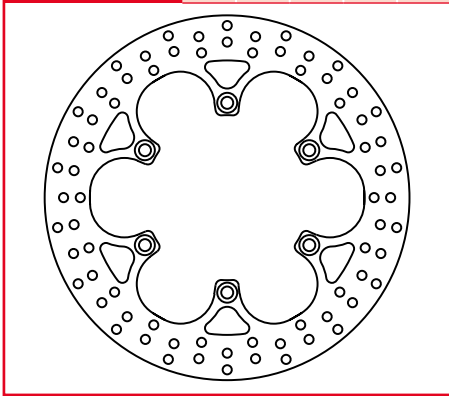

MST210

A	B	C	D	E
300	130	5		150

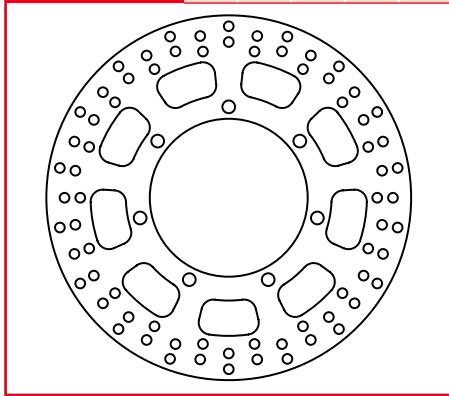

MST230

A	B	C	D	E
300	121	4		142

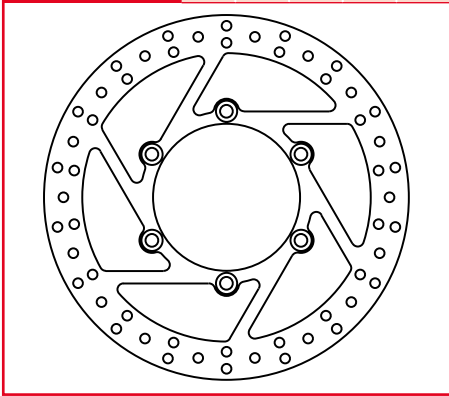

MST231

A	B	C	D	E
295	57	5		78

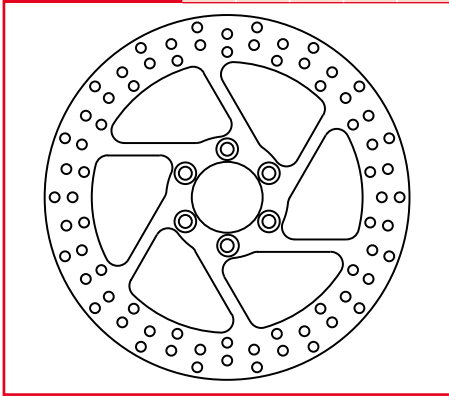

MST232

A	B	C	D	E
267	132	4		150

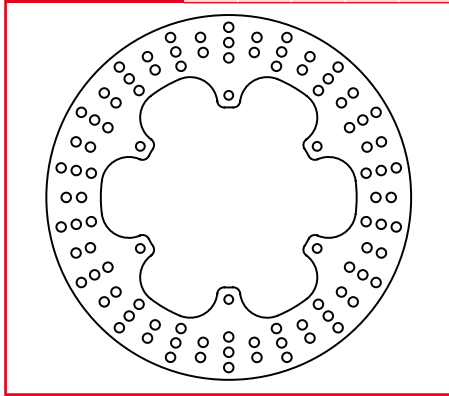



MST233

A	B	C	D	E
282	132	5		150

MST234

A	B	C	D	E
282	132	5		150

MST236

A	B	C	D	E
190	58	4		80

MST236RAC

A	B	C	D	E
190	58	4		80

MST238

A	B	C	D	E
305	181	4.5		202.5

MST238RAC

A	B	C	D	E
305	181	4.5		202.5

MST239

A	B	C	D	E
305	181	5		202.5

MST239FS

A	B	C	D	E
305	181	5		202.5

MST239RAC

A	B	C	D	E
305	181	5		202.5

MST240

A	B	C	D	E
240	105	5		125

MST240RAC

A	B	C	D	E
240	105	5		125

MST241

A	B	C	D	E
160	58	3		80



MST243

A	B	C	D	E
190	58	4		80

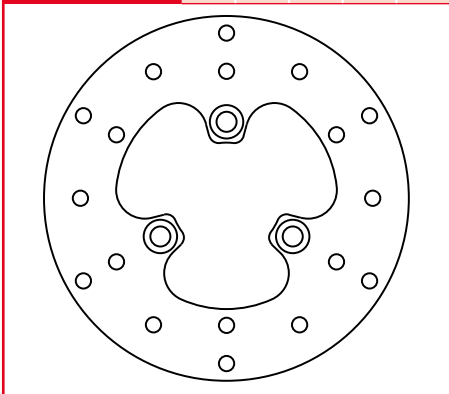

MST243RAC

A	B	C	D	E
190	58	4		80

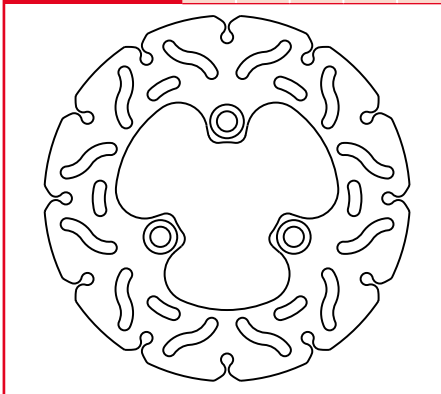

MST245

A	B	C	D	E
220	105	5		125

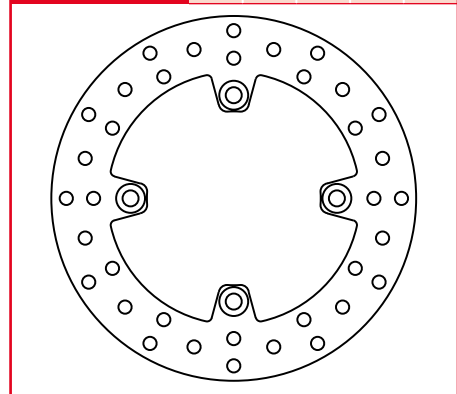

MST245RAC

A	B	C	D	E
220	105	5		125

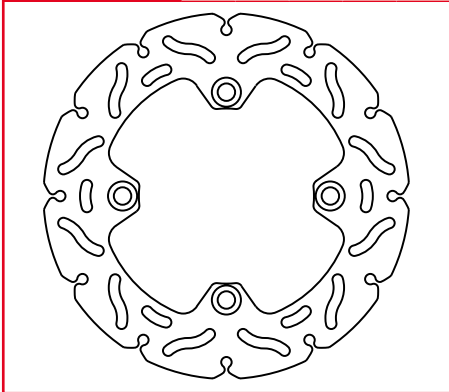

MST245SL

A	B	C	D	E
220	105	4		125

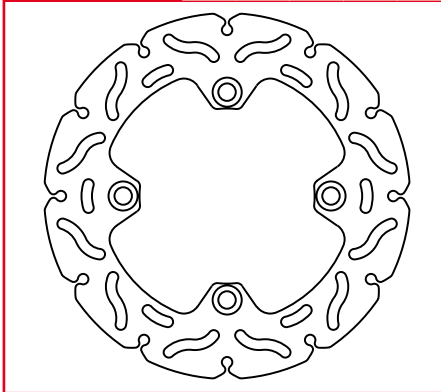

MST246

A	B	C	D	E
220	90	5		110

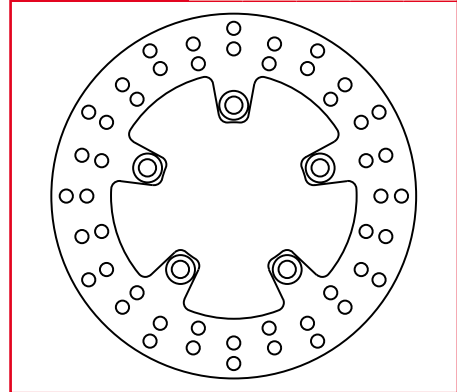

MST246RAC

A	B	C	D	E
220	89	5		110

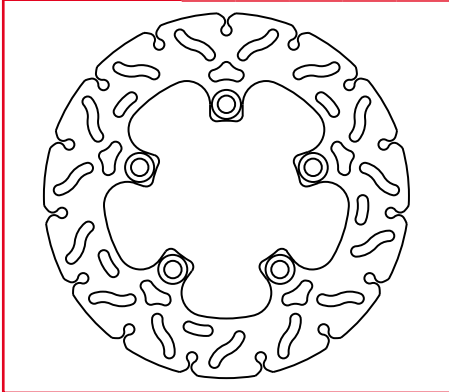

MST246SL

A	B	C	D	E
220	89	4		110

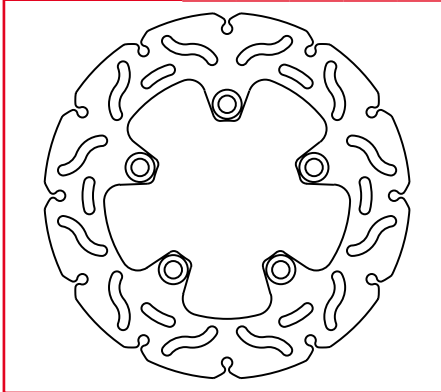

MST247

A	B	C	D	E
245	115	5		133

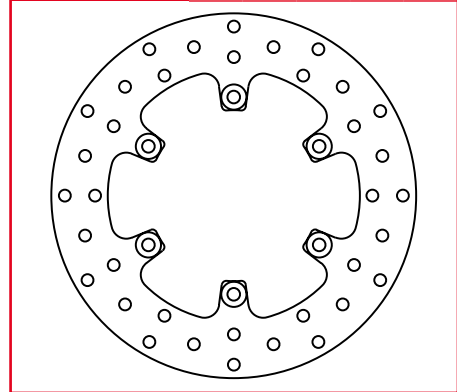

MST247RAC

A	B	C	D	E
245	115	5		133

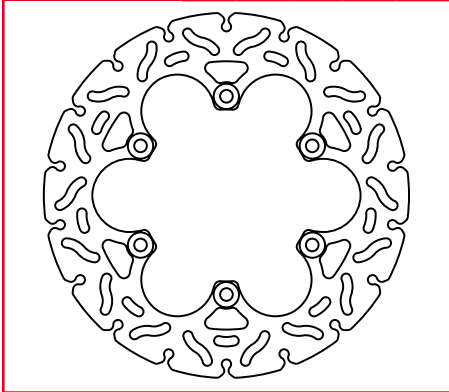

MST248

A	B	C	D	E
267	132	5		150

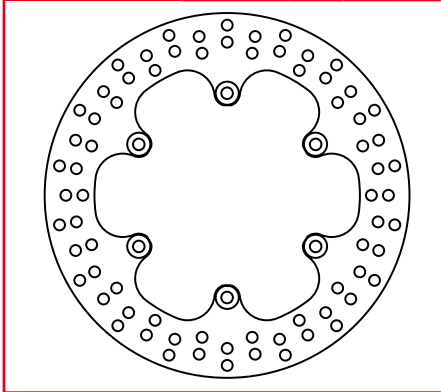

MST248RAC

A	B	C	D	E
267	132	5		150

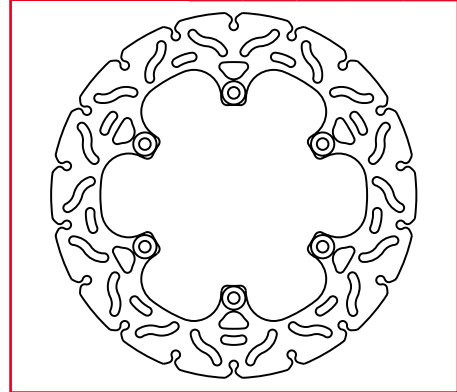



MST249

A	B	C	D	E
320	198	5		216

MST250

A	B	C	D	E
155	41	3		66

MST251

A	B	C	D	E
240	89	4		110

MST251RAC

A	B	C	D	E
240	89	4		110

MST252

A	B	C	D	E
190	58	4		80

MST252RAC

A	B	C	D	E
190	58	4		80

MST253

A	B	C	D	E
220	60	4		80

MST254

A	B	C	D	E
220	58	3		80

MST255

A	B	C	D	E
175	73	4		86

MST256

A	B	C	D	E
180	60	4		80

MST257

A	B	C	D	E
180	48	3		66

MST258

A	B	C	D	E
155	39	3		60



MST259

A	B	C	D	E
220	54	4		76.5

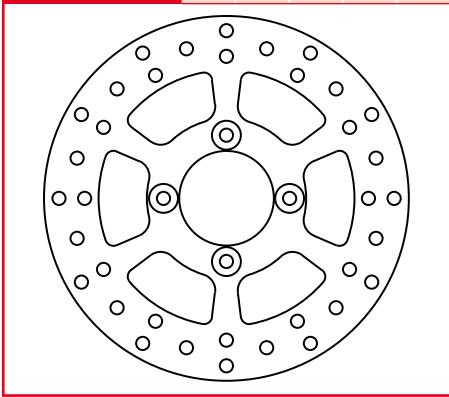

MST260

A	B	C	D	E
200	98	4		109

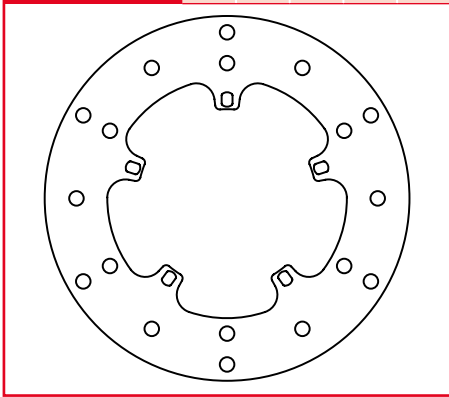

MST260RAC

A	B	C	D	E
200	98	4		109

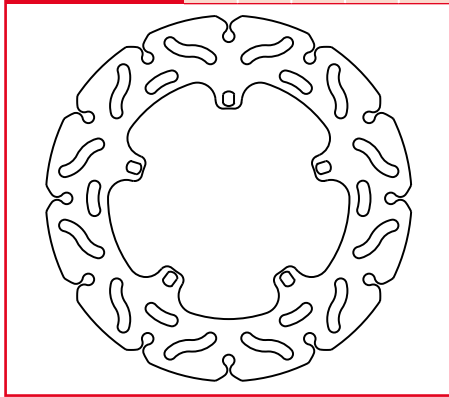

MST261

A	B	C	D	E
180	58	3		80

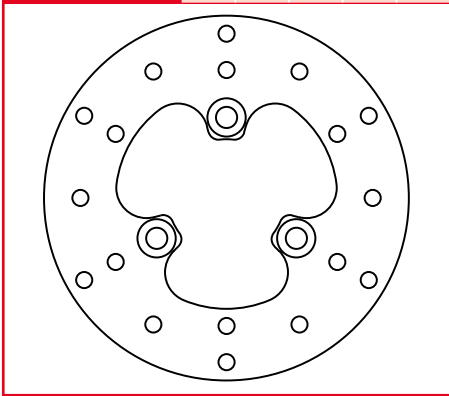

MST261RAC

A	B	C	D	E
180	58	3		80

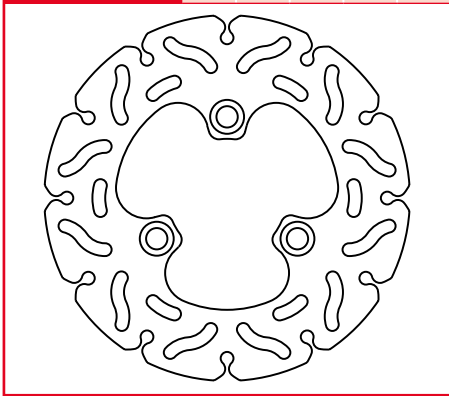

MST263

A	B	C	D	E
180	34	4		56

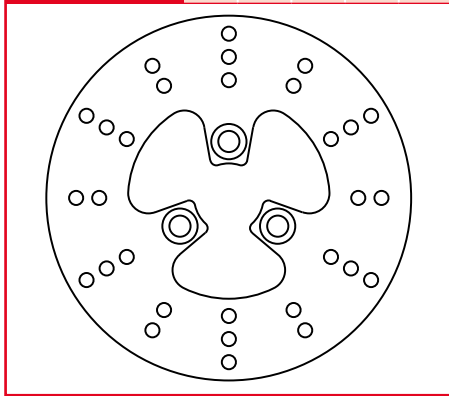

MST264

A	B	C	D	E
320	198	4		216

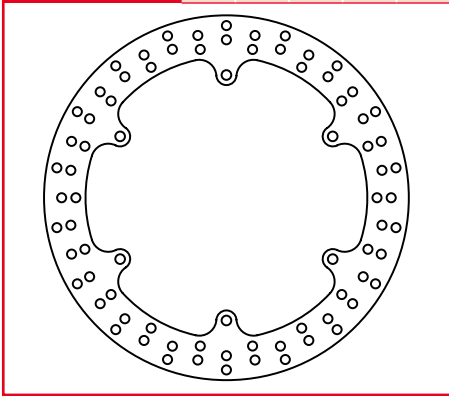

MST265

A	B	C	D	E
260	126.5	3		143

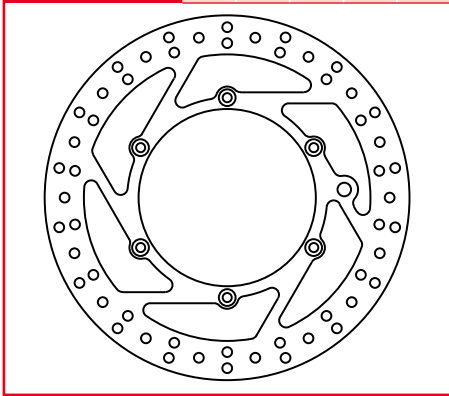

MST265EC

A	B	C	D	E
260	126.5	3		143

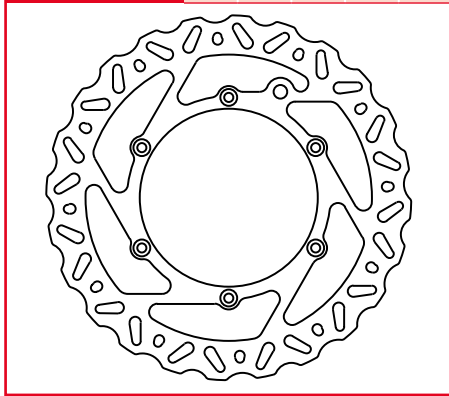

MST265RAC

A	B	C	D	E
260	126.5	3		143

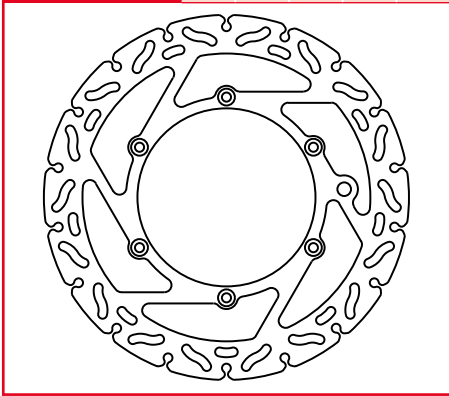

MST266

A	B	C	D	E
220	110	4		125

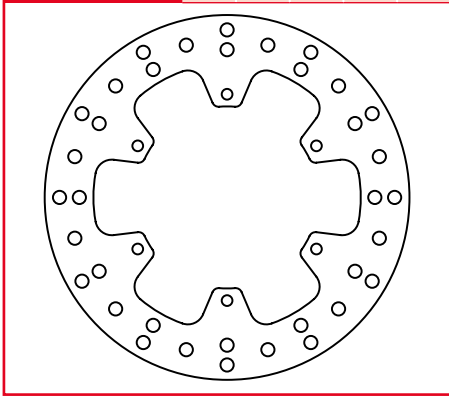

MST266EC

A	B	C	D	E
220	110	4		125

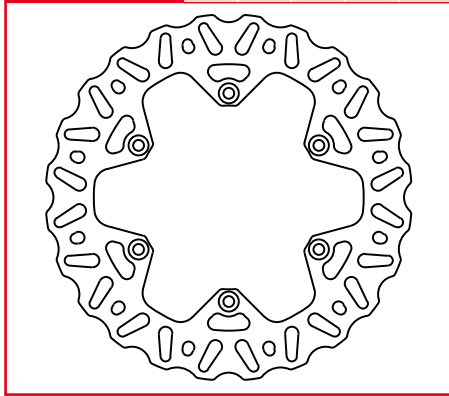



MST266RAC	A	B	C	D	E
	220	110	4		125

MST267RAC	A	B	C	D	E
	290	130.3	4.5		150

MST268RAC	A	B	C	D	E
	245	115.3	5		133

MST269RAC	A	B	C	D	E
	220	58.8	4		78

MST270RAC	A	B	C	D	E
	190	58.8	4		78

MST271RAC	A	B	C	D	E
	300	60.3	5		80

MST272RAC	A	B	C	D	E
	230	104.8	4		124

MST273RAC	A	B	C	D	E
	240	115.3	4		133

MST274	A	B	C	D	E
	256	116.3	5.9		136

MST275RAC	A	B	C	D	E
	276	144.3	4		166

MST276	A	B	C	D	E
	245	116.3	5		136

MST277RAC	A	B	C	D	E
	245	132.3	5		150



MST278

A	B	C	D	E
296	154.3	4.5		184

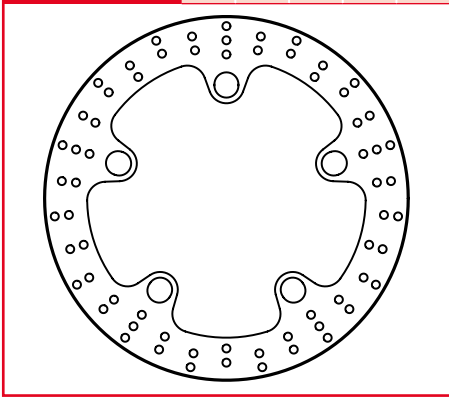

MST280

A	B	C	D	E
245	115.3	5		133

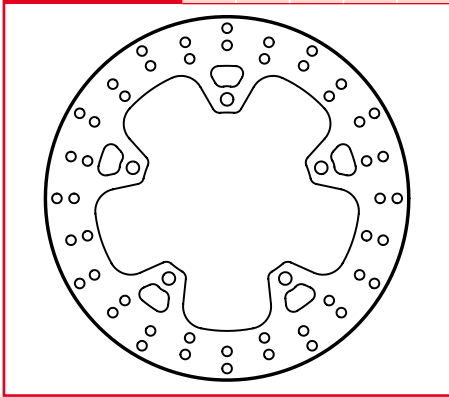

MST281EC

A	B	C	D	E
260	101.3	3		117

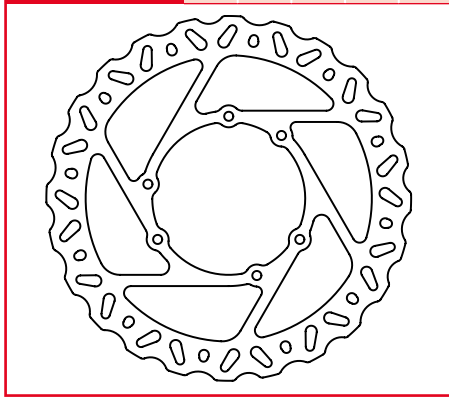

MST282EC

A	B	C	D	E
270	109.3	3		126

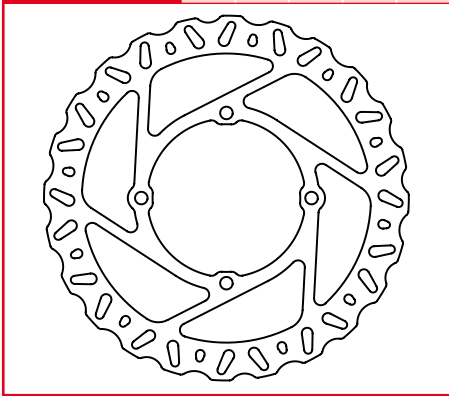

MST283RAC

A	B	C	D	E
245	115.3	4		133

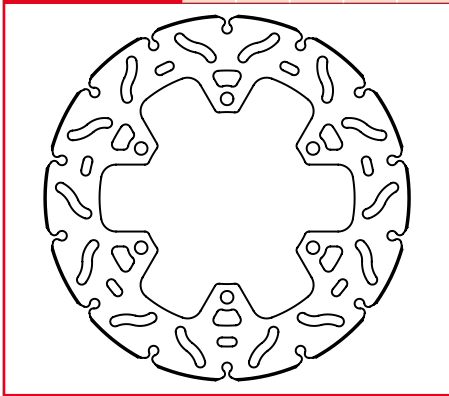

MST284RAC

A	B	C	D	E
298	132.3	5.5		150

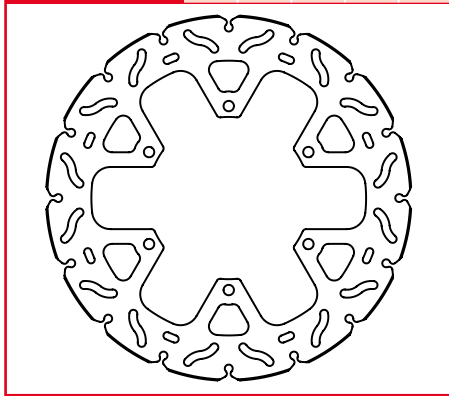

MST285RAC

A	B	C	D	E
220	105.3	4.5		125

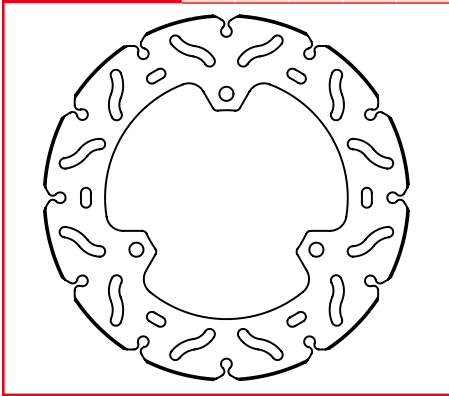

MST286RAC

A	B	C	D	E
250	71	5		120

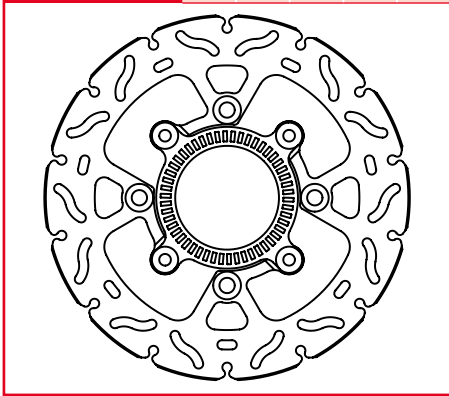

MST287RAC

A	B	C	D	E
245	83.3	5		102

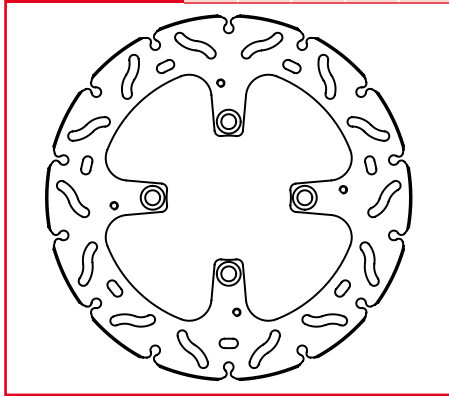

MST288RAC

A	B	C	D	E
220	100.3	5		120

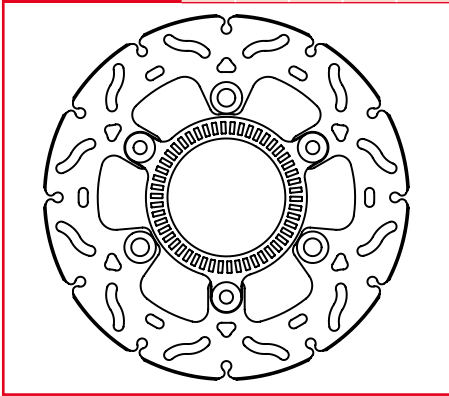

MST289RAC

A	B	C	D	E
240	89.3	5		108

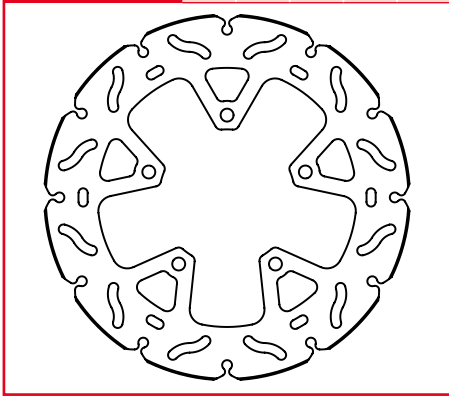

MST290

A	B	C	D	E
267	110.3	5		125

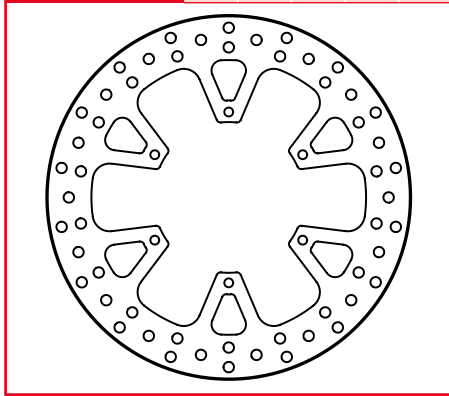



MST298

A	B	C	D	E
260	125.3	4		140

MST300

A	B	C	D	E
240	118	3		134

MST301

A	B	C	D	E
240	101	3		117

MST301EC

A	B	C	D	E
240	101	3		117

MST302

A	B	C	D	E
220	88	3		106

MST302EC

A	B	C	D	E
220	88	3		106

MST303

A	B	C	D	E
260	108	3		125

MST304EC

A	B	C	D	E
250	118	3		134

MST304RAC

A	B	C	D	E
250	118	3		134

MST305EC

A	B	C	D	E
240	122	4		140

MST305RAC

A	B	C	D	E
240	122	4		140

MST306

A	B	C	D	E
250	100	3		116



MST307

A	B	C	D	E
250	100	3		116

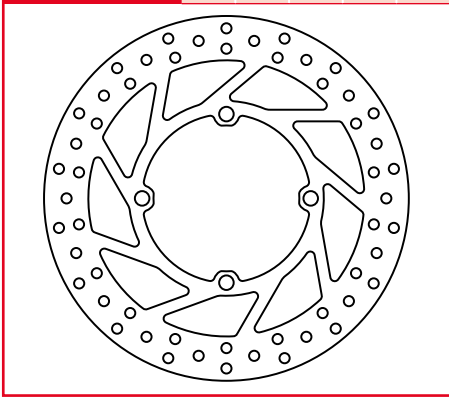

MST307RAC

A	B	C	D	E
250	100	3		116

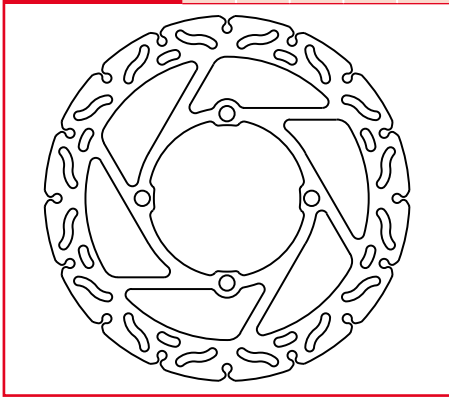

MST308EC

A	B	C	D	E
250	109	3		126

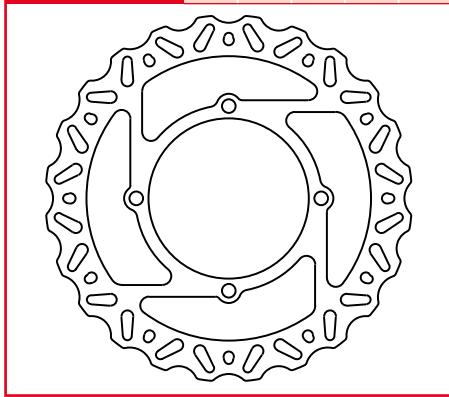

MST308RAC

A	B	C	D	E
250	109	3		126

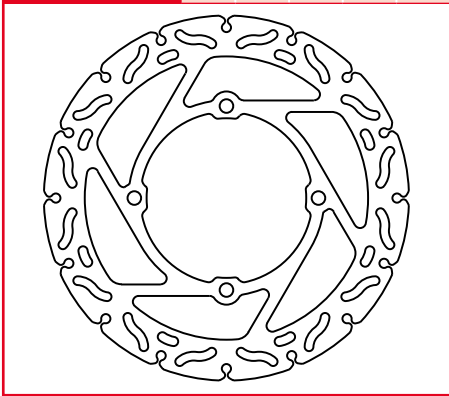

MST309EC

A	B	C	D	E
218.5	95	3		110

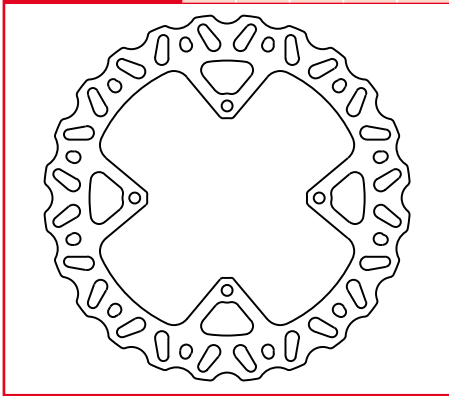

MST310

A	B	C	D	E
300	126.5	4		143

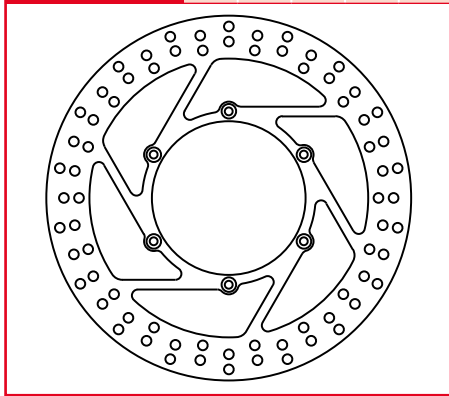

MST311

A	B	C	D	E
250	118	3		134

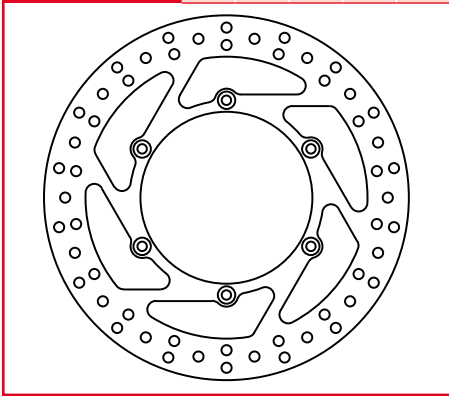

MST311EC

A	B	C	D	E
250	118	3		134

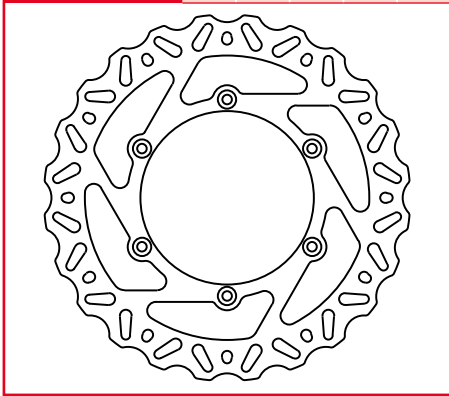

MST311RAC

A	B	C	D	E
250	118	3		134

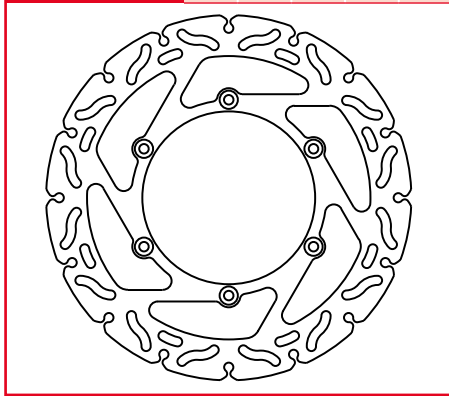

MST312RAC

A	B	C	D	E
220	100	3		120

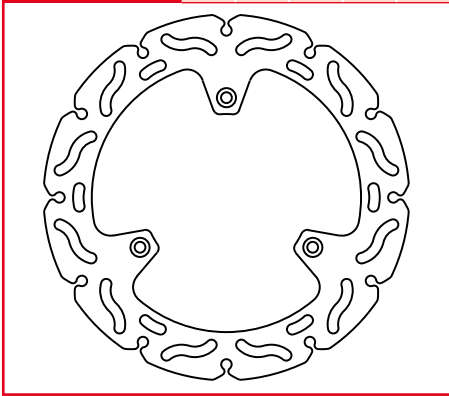

MST313RAC

A	B	C	D	E
200	84.5	3		100

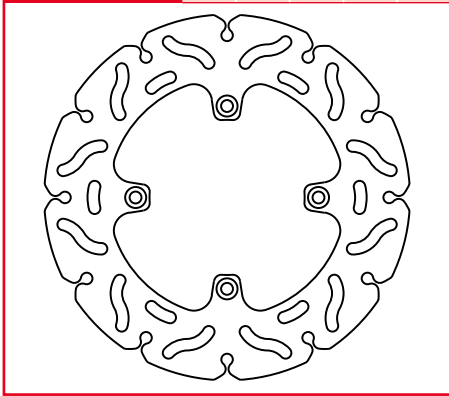

MST314EC

A	B	C	D	E
200	110	3		125

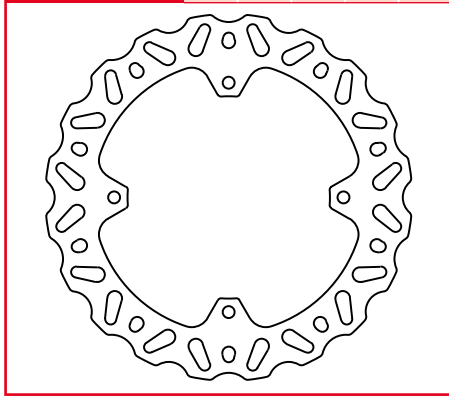



MST315

A	B	C	D	E
290	121	4		142

MST316

A	B	C	D	E
245	118	3		134

MST317

A	B	C	D	E
267	118	4		134

MST318EC

A	B	C	D	E
220	100	3		120

MST319

A	B	C	D	E
260	120	3		135

MST320

A	B	C	D	E
260	120	3		135

MST320EC

A	B	C	D	E
260	120	3		135

MST321

A	B	C	D	E
220	121	4		140

MST322

A	B	C	D	E
240	121	4		140

MST323

A	B	C	D	E
220	105	4		125

MST324

A	B	C	D	E
190	80	3		94

MST324EC

A	B	C	D	E
190	80	3		94



MST325

A	B	C	D	E
256	144	4		166

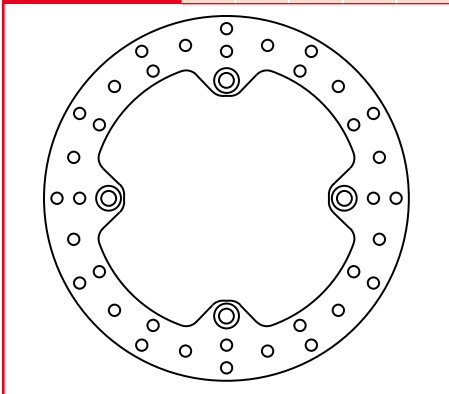

MST326

A	B	C	D	E
220	105	5		125

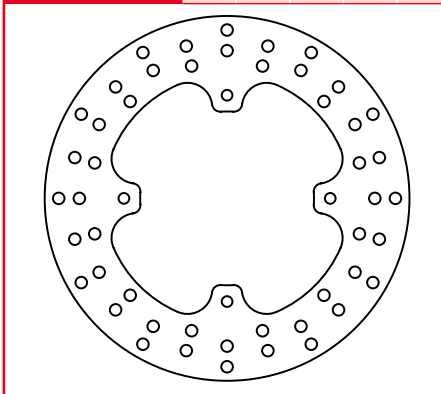

MST328

A	B	C	D	E
240	121	4		140

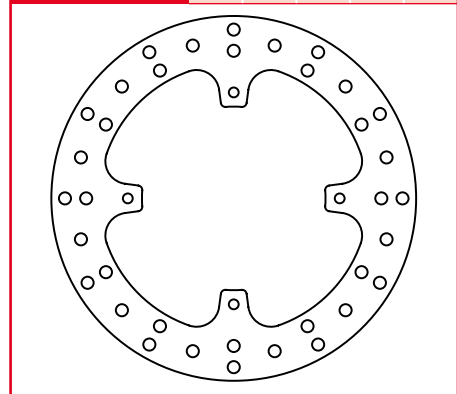

MST328EC

A	B	C	D	E
240	121	4		140

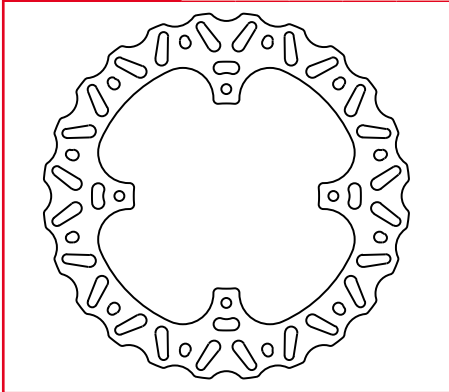

MST328RAC

A	B	C	D	E
240	121	4		140

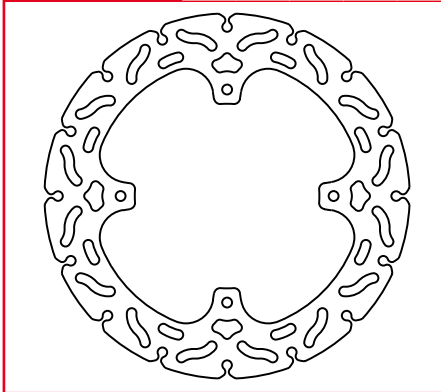

MST330

A	B	C	D	E
240	110	5		124

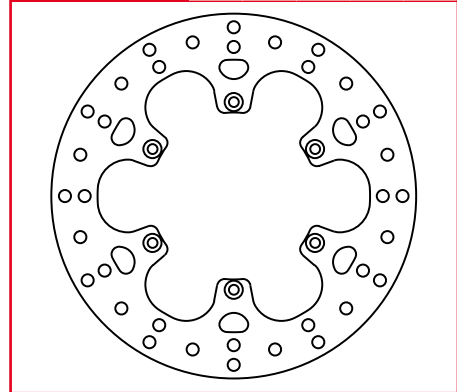

MST331

A	B	C	D	E
276	174	5		198

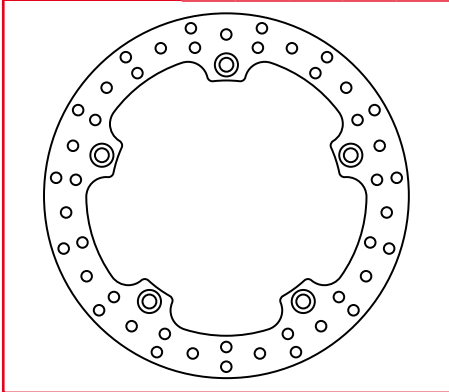

MST331RAC

A	B	C	D	E
276	174	5		198

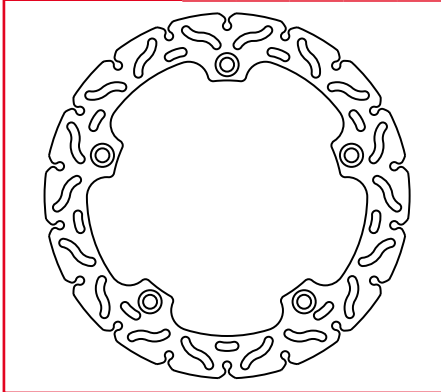

MST332

A	B	C	D	E
184	84	3		100

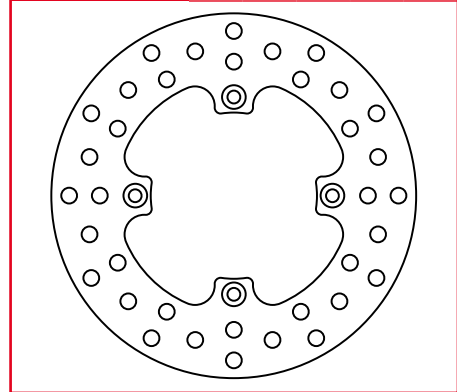

MST333

A	B	C	D	E
220	100	4		116

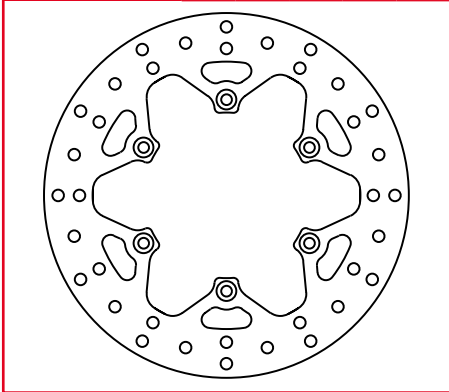

MST335

A	B	C	D	E
220	100	4		116

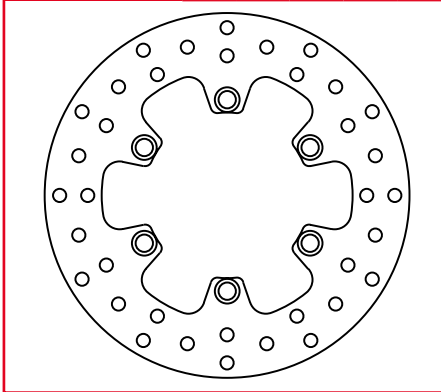

MST336

A	B	C	D	E
220	100	4		116

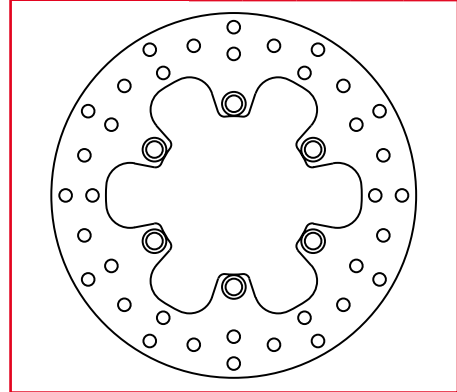



MST337

A	B	C	D	E
298	105	4		120

MST337RAC

A	B	C	D	E
298	105	4		120

MST338

A	B	C	D	E
240	116	5		136

MST338RAC

A	B	C	D	E
240	116	5		136

MST339

A	B	C	D	E
240	115	4		133

MST339EC

A	B	C	D	E
240	115	4		133

MST339RAC

A	B	C	D	E
240	115	4		133

MST340

A	B	C	D	E
220	83.5	4		104

MST341

A	B	C	D	E
220	118	4		134

MST341RAC

A	B	C	D	E
220	118	4		134

MST342

A	B	C	D	E
240	118	4		134

MST342RAC

A	B	C	D	E
240	118	4		134



MST343RAC

A	B	C	D	E
260	140	5		161

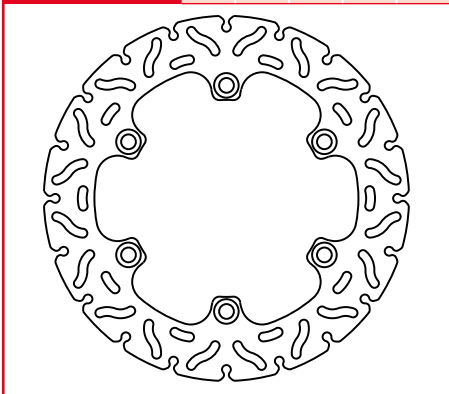

MST346

A	B	C	D	E
220	115	4		133

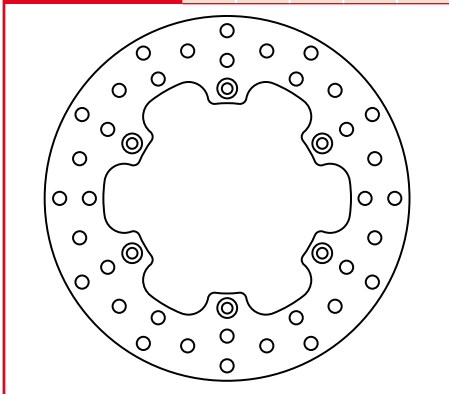

MST347

A	B	C	D	E
240	115	4		133

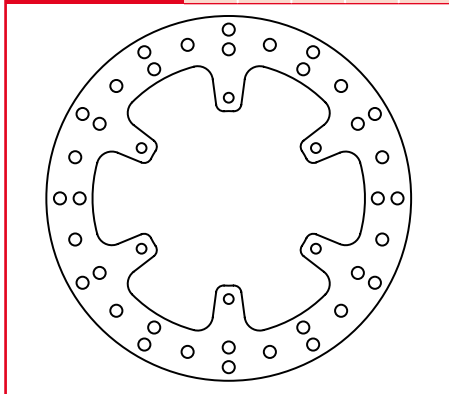

MST348

A	B	C	D	E
190	84	3		100

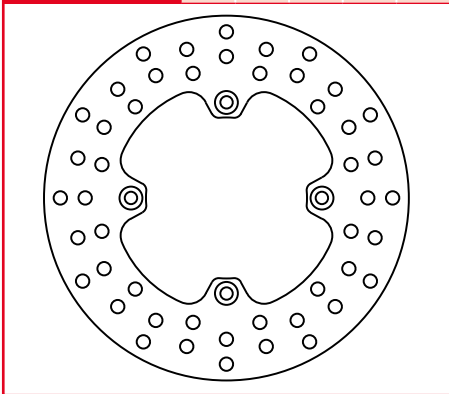

MST348EC

A	B	C	D	E
190	84	3		100

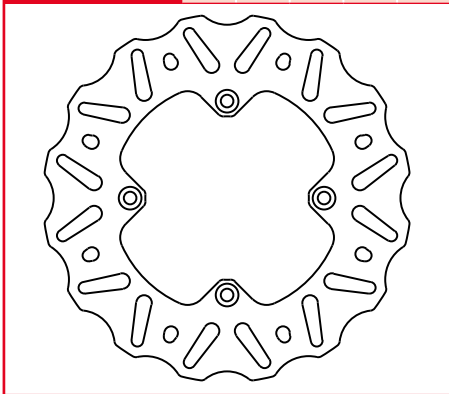

MST349

A	B	C	D	E
220	86	5		102

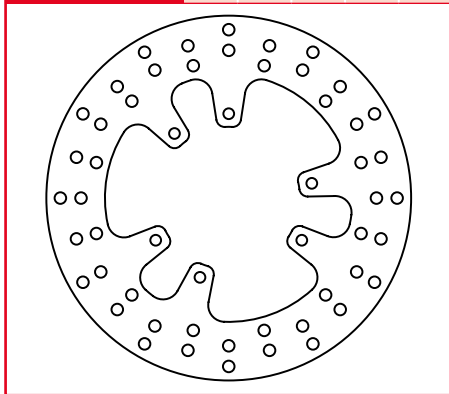

MST350

A	B	C	D	E
245	115	4		133

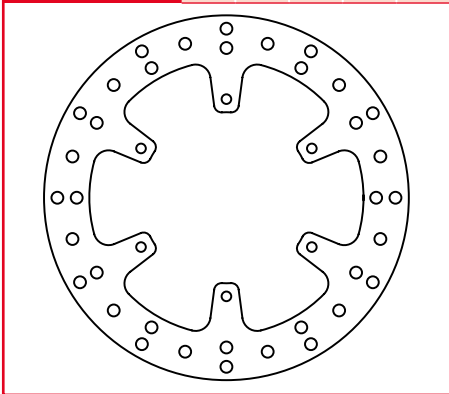

MST350EC

A	B	C	D	E
245	115	4		133

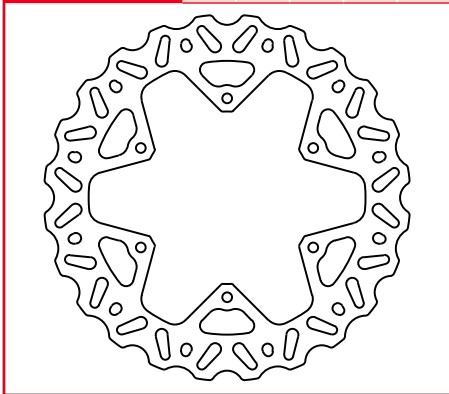

MST350RAC

A	B	C	D	E
245	115	4		133

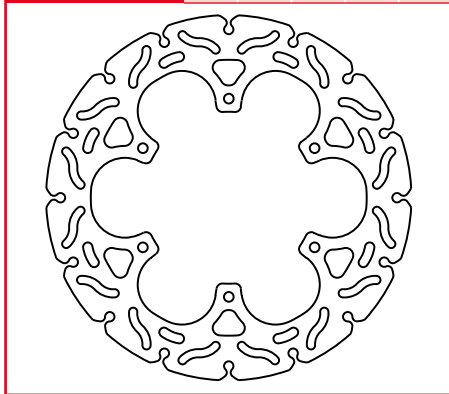

MST351

A	B	C	D	E
220	112	4		130

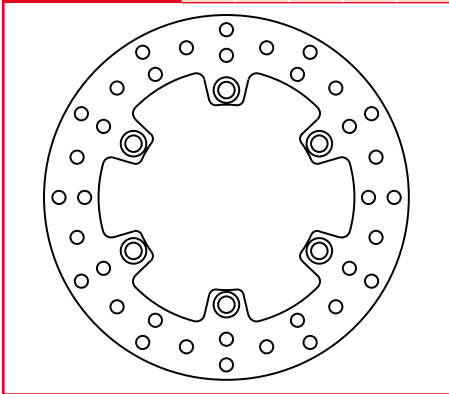

MST353

A	B	C	D	E
220	112	4		130

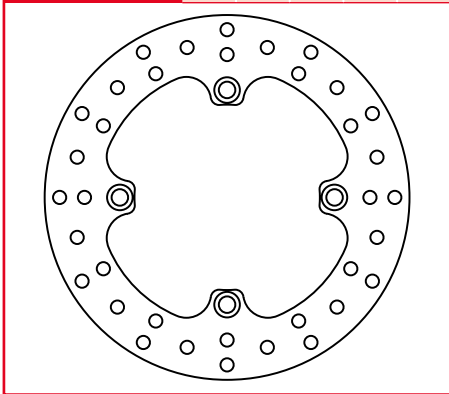

MST355

A	B	C	D	E
230	86	3		100

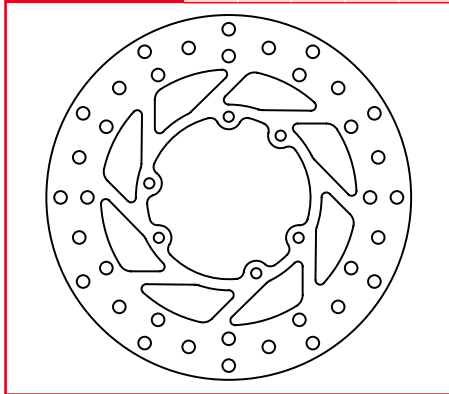



MST356

A	B	C	D	E
320	181	4.5		202.5

MST356RAC

A	B	C	D	E
320	181	4.5		202.5

MST357

A	B	C	D	E
320	181	5		202.5

MST357FS

A	B	C	D	E
320	181	5		202.5

MST357RAC

A	B	C	D	E
320	181	5		202.5

MST362

A	B	C	D	E
220	106	5		125

MST362RAC

A	B	C	D	E
220	106	5		125

MST362SL

A	B	C	D	E
220	106	4		125

MST363

A	B	C	D	E
220	116	5		133

MST364

A	B	C	D	E
250	84	5		100

MST365

A	B	C	D	E
275	57	5		78

MST366

A	B	C	D	E
220	100	5		120



MST366RAC

A	B	C	D	E
220	100	5		120

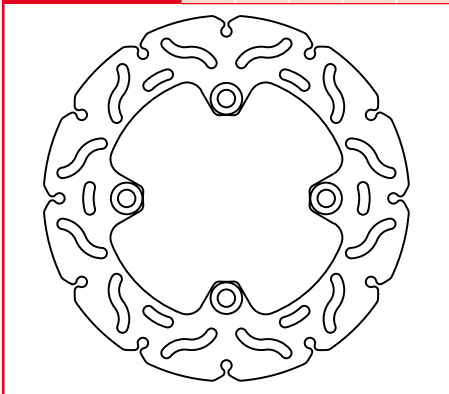

MST366SL

A	B	C	D	E
220	100	4		120

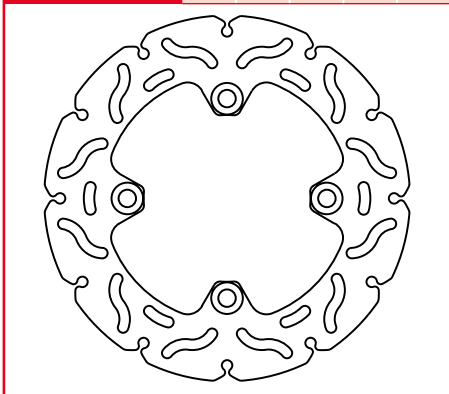

MST367

A	B	C	D	E
230	83	4		104

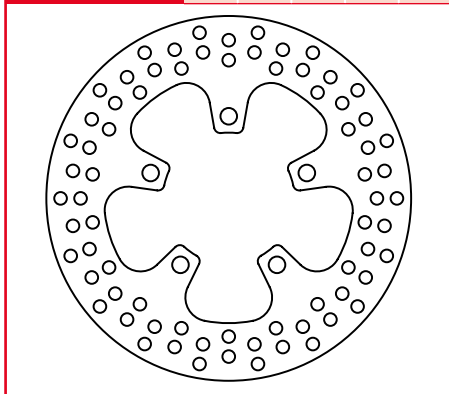

MST368

A	B	C	D	E
260	141	5		162

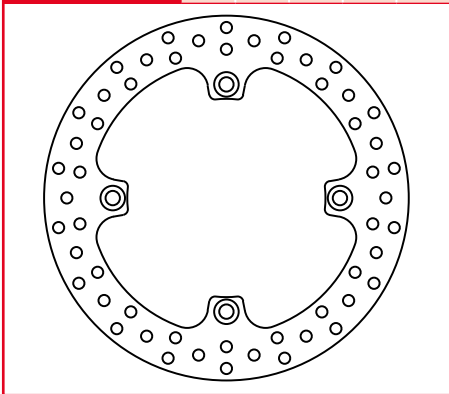

MST369

A	B	C	D	E
245	115	4		133

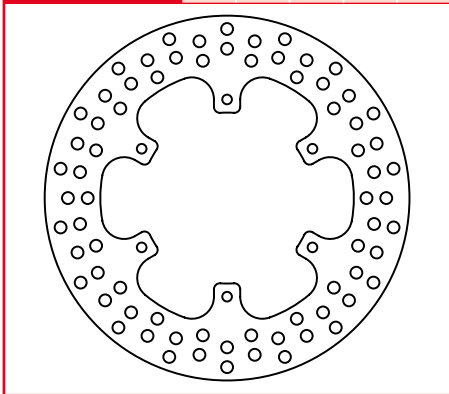

MST370

A	B	C	D	E
245	80	4		98

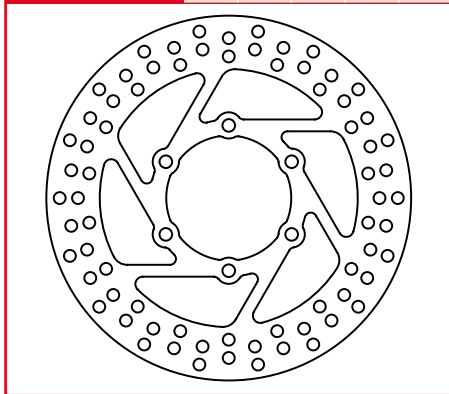

MST371EC

A	B	C	D	E
240	118	4		134

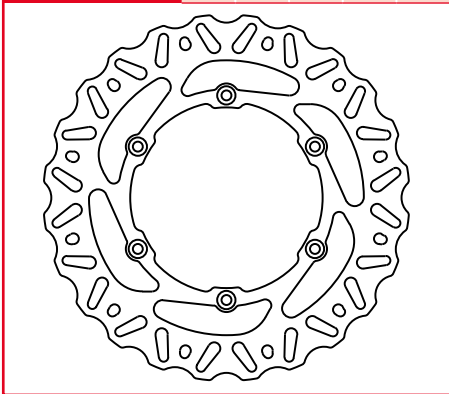

MST371RAC

A	B	C	D	E
240	118	4		134

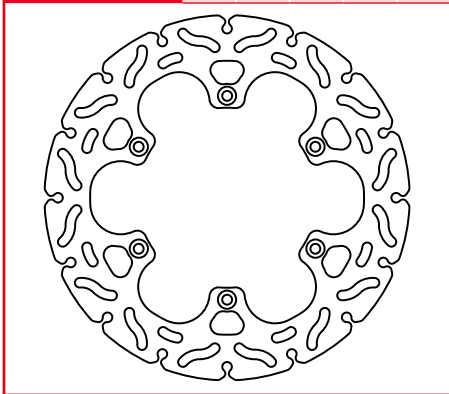

MST372

A	B	C	D	E
265	136.5	5		160

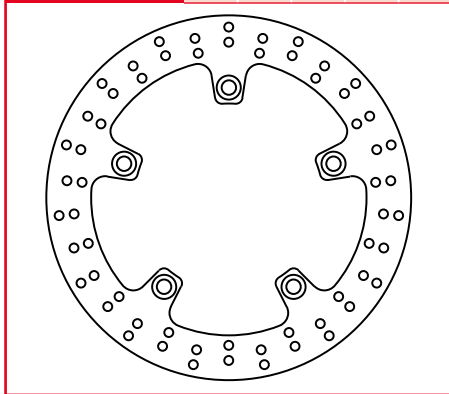

MST372RAC

A	B	C	D	E
265	136.5	5		160

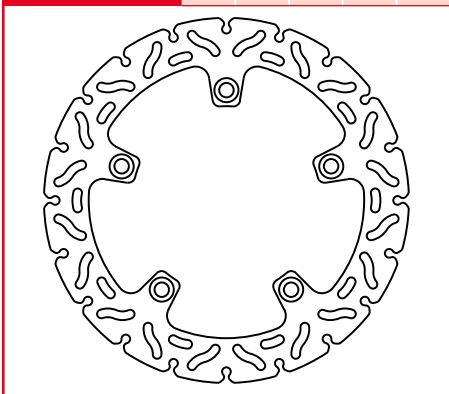

MST373

A	B	C	D	E
256	145	5		166

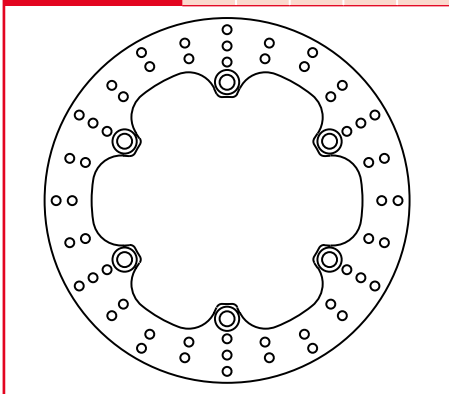

MST373RAC

A	B	C	D	E
256	145	5		166

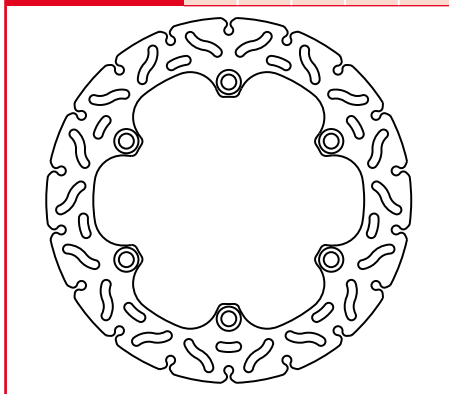



MST374

A	B	C	D	E
245	105	5		125

MST374RAC

A	B	C	D	E
245	105	5		125

MST375RAC

A	B	C	D	E
250	110	5		130

MST376RAC

A	B	C	D	E
220	102.8	5		120

MST377RAC

A	B	C	D	E
245	108	5		125

MST378RAC

A	B	C	D	E
240	107.5	5		130

MST379

A	B	C	D	E
300	126.5	4		143

MST380

A	B	C	D	E
260	121.5	5		142

MST381

A	B	C	D	E
210	90	5		110

MST382

A	B	C	D	E
240	92.5	5		114

MST383

A	B	C	D	E
292	155	4		170

MST384

A	B	C	D	E
180	63.5	4		82.5



MST385

A	B	C	D	E
200	76	4		102

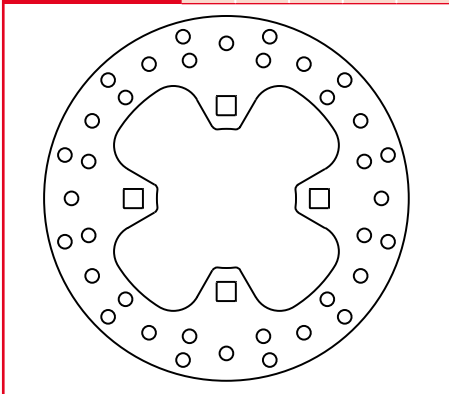

MST386

A	B	C	D	E
240	120.5	5		141

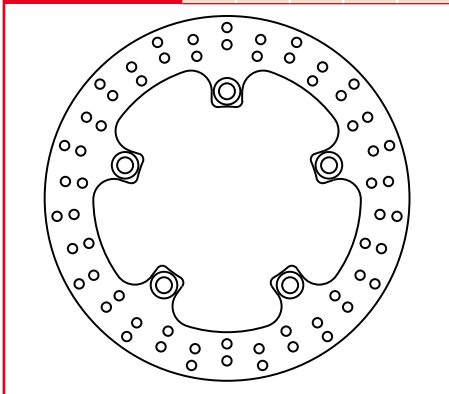

MST386RAC

A	B	C	D	E
240	120.5	5		141

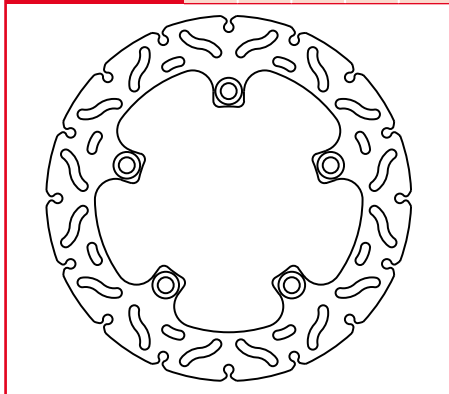

MST387

A	B	C	D	E
298	105	4		120

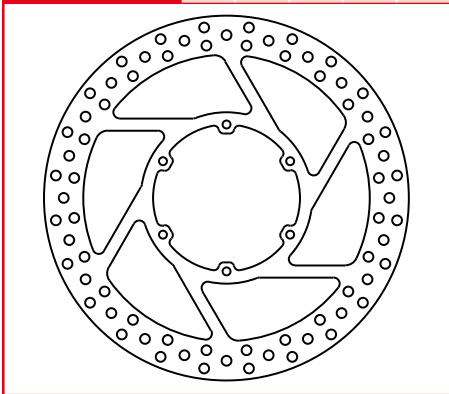

MST388RAC

A	B	C	D	E
230	115	4		133

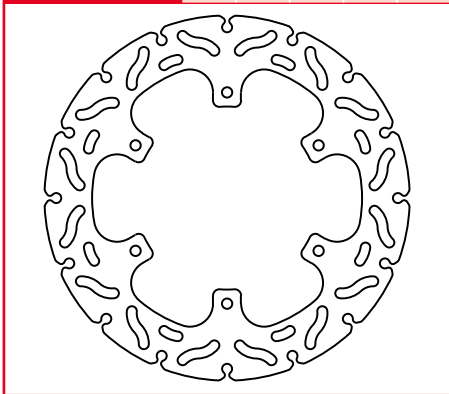

MST389

A	B	C	D	E
230	102	4		120

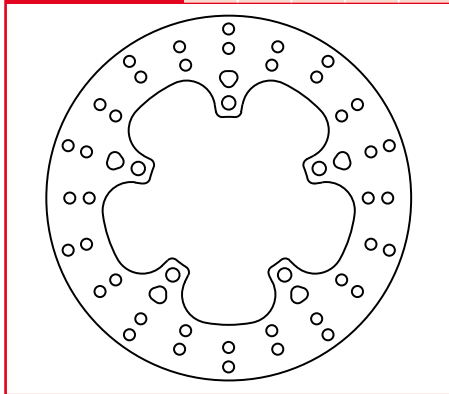

MST390RAC

A	B	C	D	E
256	70	5		110

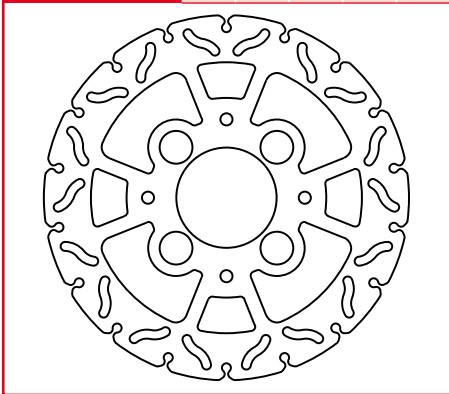

MST391

A	B	C	D	E
294	136.5	5		160

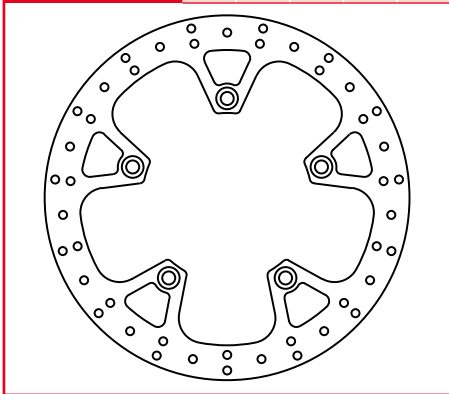

MST392

A	B	C	D	E
220	119	5		136

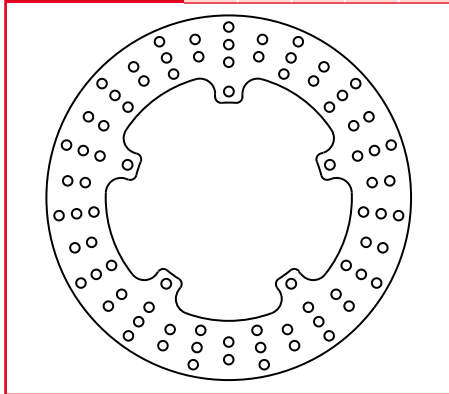

MST392RAC

A	B	C	D	E
220	119	5		136

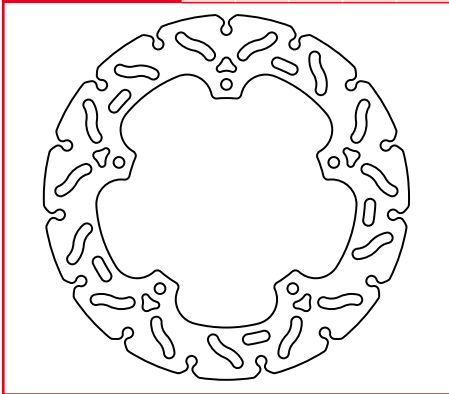

MST393

A	B	C	D	E
260	125.3	5		140

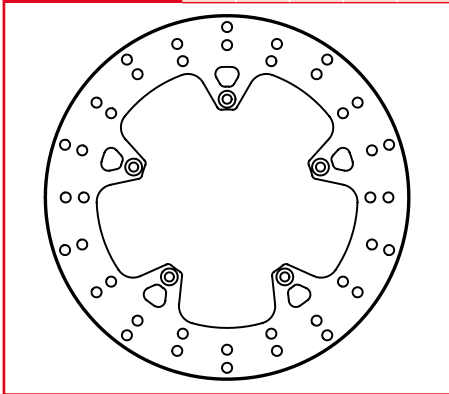

MST394

A	B	C	D	E
240	105	4		120

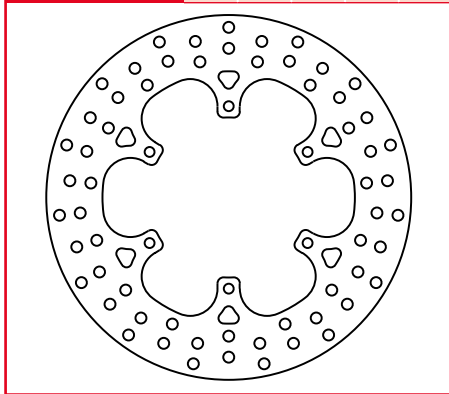



MST395

A	B	C	D	E
240	125	5		140

MST396

A	B	C	D	E
220	105.3	4		120

MST397RAC

A	B	C	D	E
220	100	5		120

MST398

A	B	C	D	E
256	94	5		110

MST399

A	B	C	D	E
240	126	4		130

MST400

A	B	C	D	E
165	48	4		66

MST401

A	B	C	D	E
196	81	4		100

MST402

A	B	C	D	E
170	48.5	3		68

MST403

A	B	C	D	E
174	53	3		72

MST404

A	B	C	D	E
220	58	4		80

MST405

A	B	C	D	E
161	48	4		66

MST406

A	B	C	D	E
245	58	4		76



MST407

A	B	C	D	E
220	58	4		76

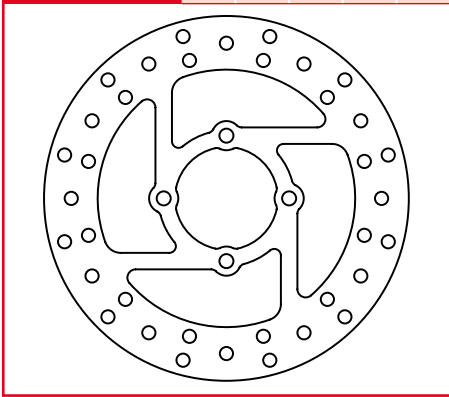

MST408

A	B	C	D	E
163	51	3		72

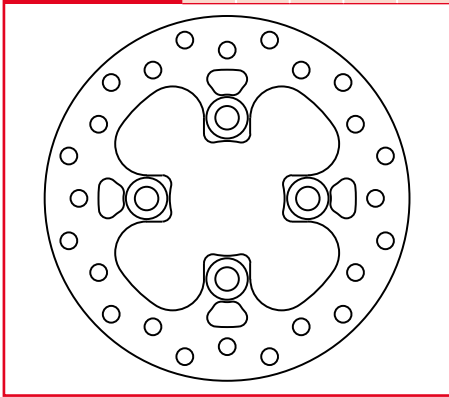

MST409

A	B	C	D	E
260	60	4		80

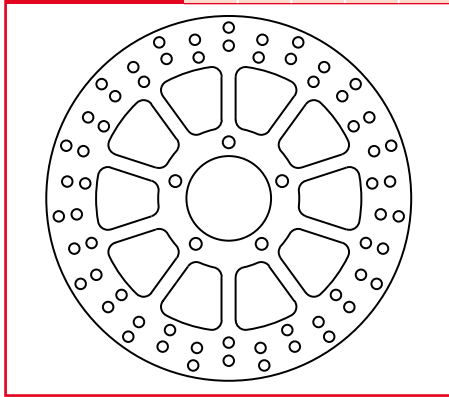

MST410

A	B	C	D	E
200	51	4		71

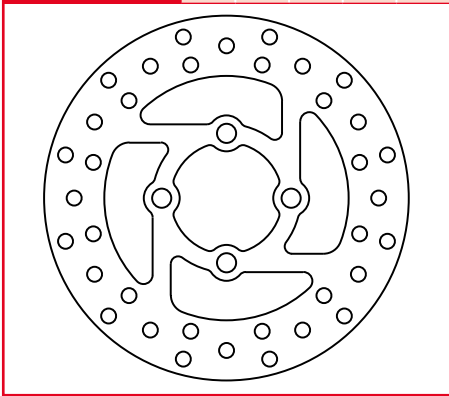

MST411

A	B	C	D	E
160	48.5	3		68

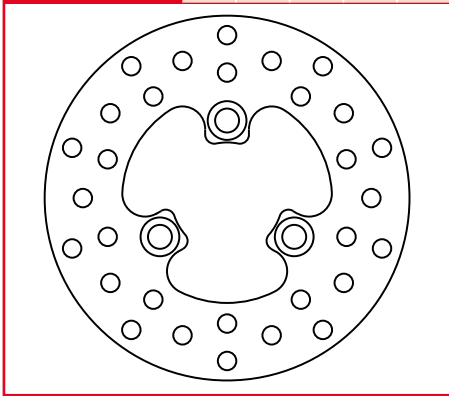

MST412

A	B	C	D	E
190	78.5	4		98

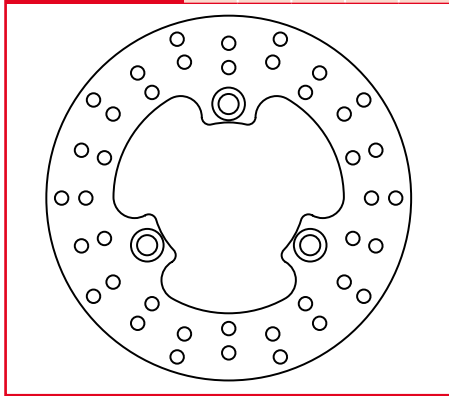

MST413

A	B	C	D	E
200	72	4		90

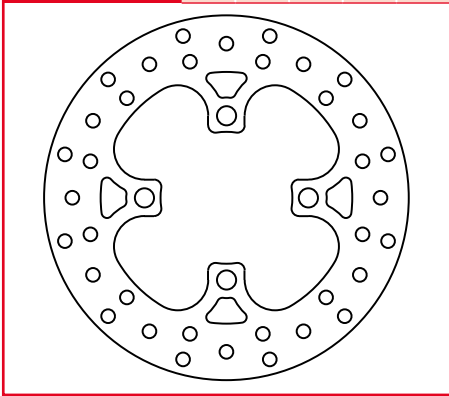

MST414

A	B	C	D	E
200	89.5	4		110

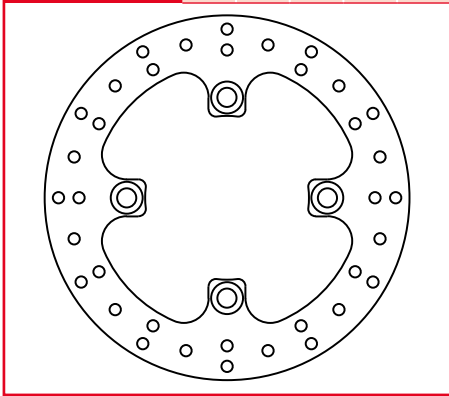

MST415

A	B	C	D	E
200	84	3		104

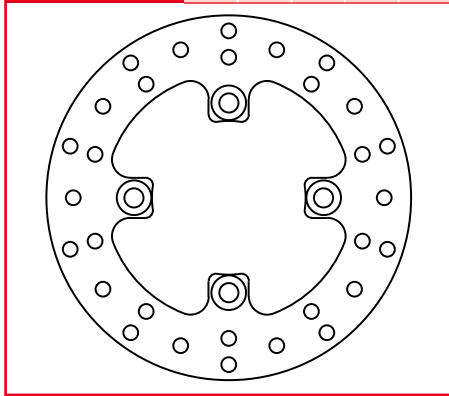

MST416

A	B	C	D	E
220	95.5	4		117

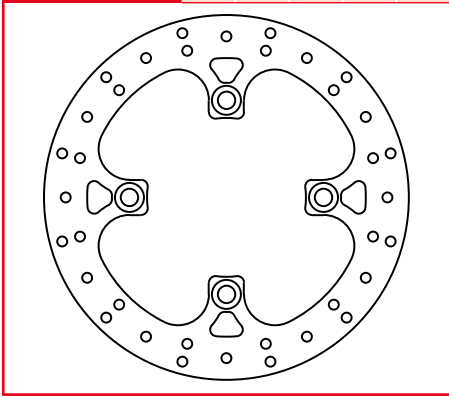

MST417

A	B	C	D	E
205	98	4		117

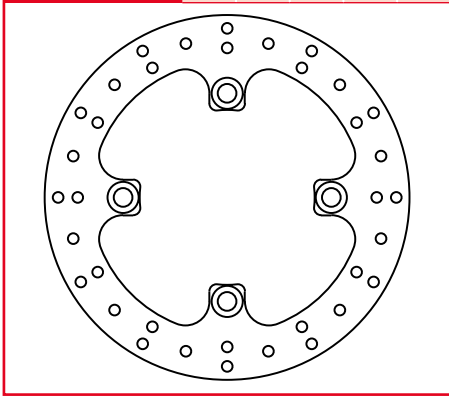

MST418RAC

A	B	C	D	E
260	105	3		120

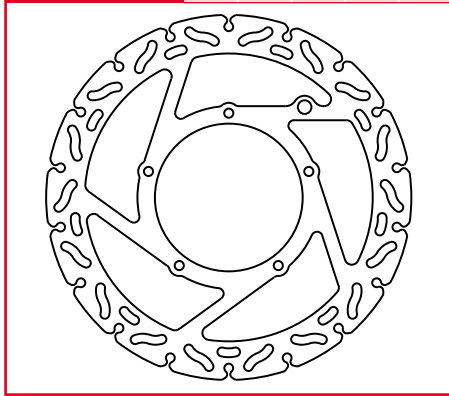



MST419RAC	A	B	C	D	E
	240	107	5		125

MST420RAC	A	B	C	D	E
	245	106	5		125

MST421RAC	A	B	C	D	E
	290	130	4.5		150

MST422RAC	A	B	C	D	E
	220	100	5		120

MST423	A	B	C	D	E
	267	132	5		150

MST424	A	B	C	D	E
	276	88	4		110

MST425RAC	A	B	C	D	E
	220	105	5		125

MST426	A	B	C	D	E
	256	70	5		110

MST427RAC	A	B	C	D	E
	220	105	5		125

MST428	A	B	C	D	E
	316	184	6		205

MST429RAC	A	B	C	D	E
	220	102	5		120

MST430	A	B	C	D	E
	240	102	5		120



MST431

A	B	C	D	E
260	100	5		120

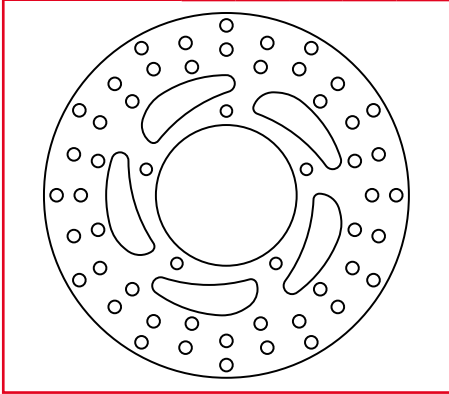

MST432

A	B	C	D	E
282	132	5		150

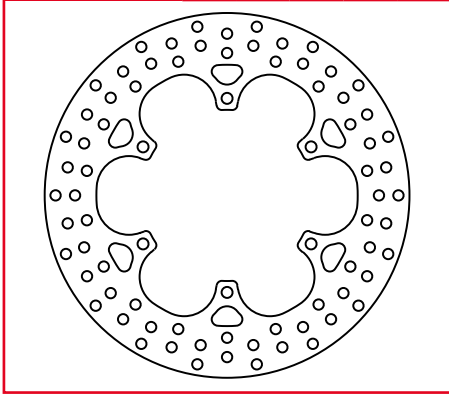

MST433RAC

A	B	C	D	E
298	132	5.5		150

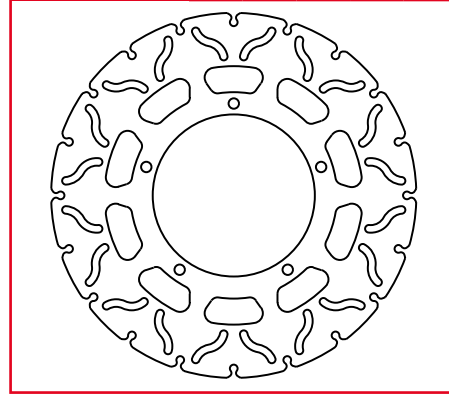

MST434

A	B	C	D	E
255	105	5.5		125

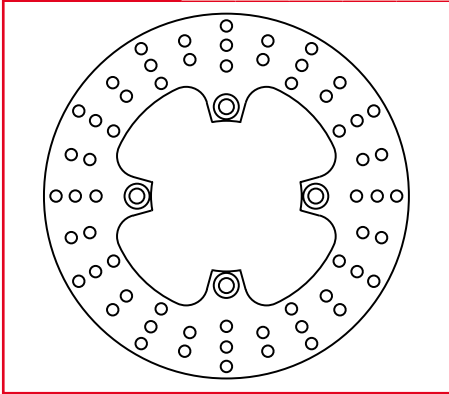

MST436

A	B	C	D	E
220	105.3	5.5		125

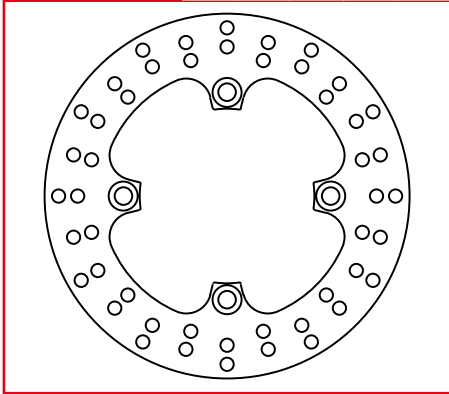

MST437

A	B	C	D	E
240	90	5		110

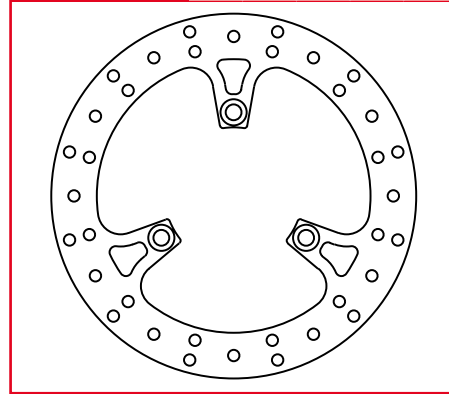

MST438

A	B	C	D	E
240	110	5		125

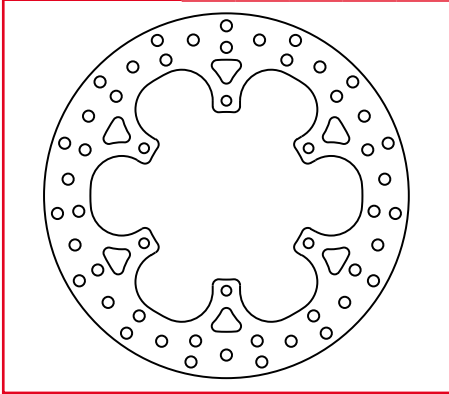

MST439

A	B	C	D	E
240	110	5		125

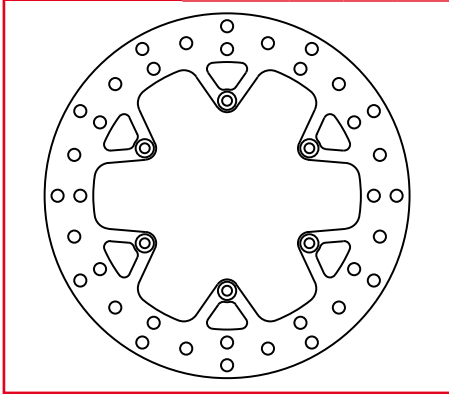

MST440EC

A	B	C	D	E
240	112	4		130

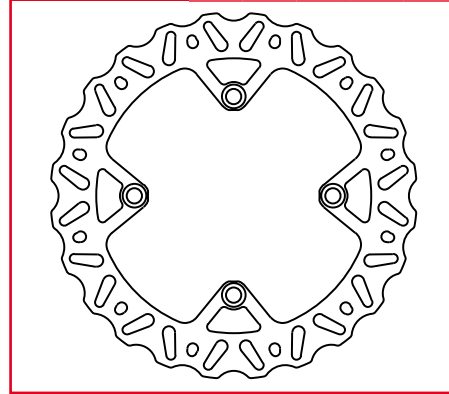

MST441EC

A	B	C	D	E
220	96	3		112

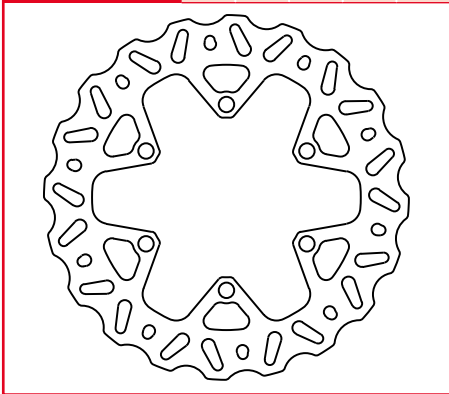

MST442EC

A	B	C	D	E
184	84	3		100

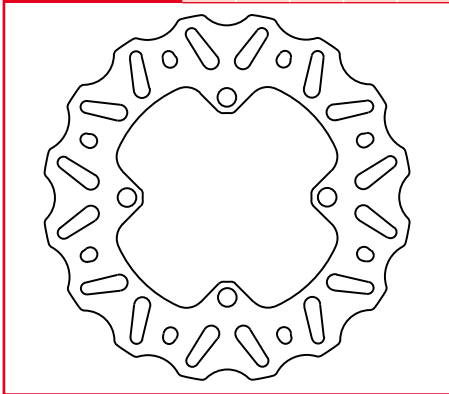

MST443EC

A	B	C	D	E
180	79	3		95

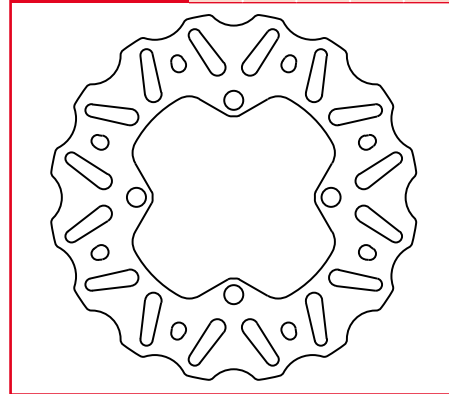



MST444	A	B	C	D	E
	255	105.3	5		125

MST445RAC	A	B	C	D	E
	220	100.3	5		120

MST446RAC	A	B	C	D	E
	240	117.3	5		136

MST447RAC	A	B	C	D	E
	320	210.3	5		230

MST448	A	B	C	D	E
	276	170.3	5		190

MST449	A	B	C	D	E
	310	165.3	4.5		195

MST450	A	B	C	D	E
	256	144.3	4.5		166

MST452	A	B	C	D	E
	220	58.3	3.5		78

MST453	A	B	C	D	E
	240	105.3	4		125

MST454	A	B	C	D	E
	256	101.3	3.1		117

MST455	A	B	C	D	E
	220	105.3	5		125

MST456	A	B	C	D	E
	270	150.3	5		175



MST457

A	B	C	D	E
270	129.3	5		146

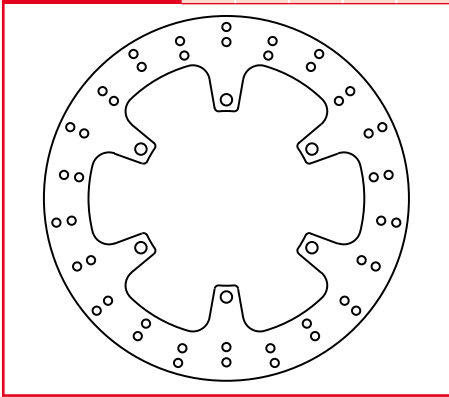

MST458

A	B	C	D	E
300	145.3	5		170

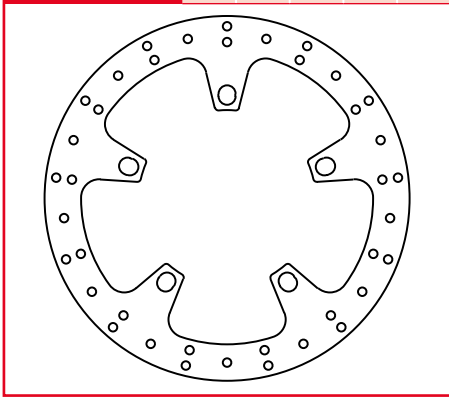

MST459

A	B	C	D	E
280	142.3	5		163.5

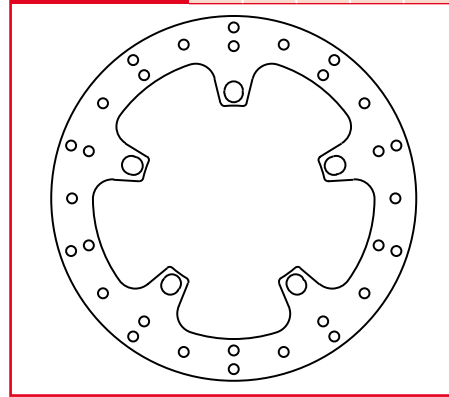

MST460

A	B	C	D	E
290	120.8	5		141

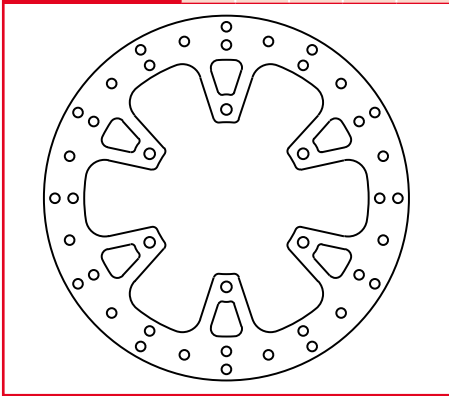

MST461RAC

A	B	C	D	E
245	83.3	5		102

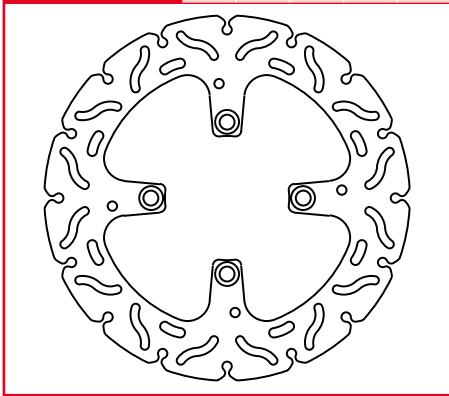

MST462

A	B	C	D	E
282	105.3	5		127.5

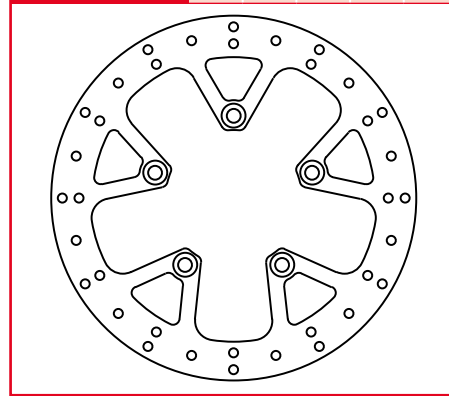

MST463EC

A	B	C	D	E
210	110.3	3.1		125

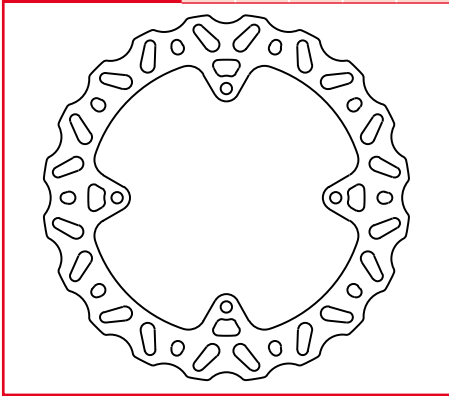

MST464

A	B	C	D	E
276	136	5		160

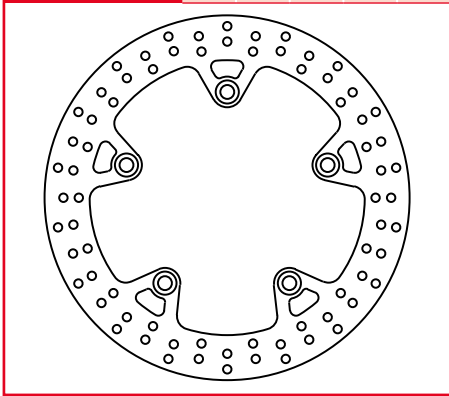

MST464RAC

A	B	C	D	E
276	136	5		160

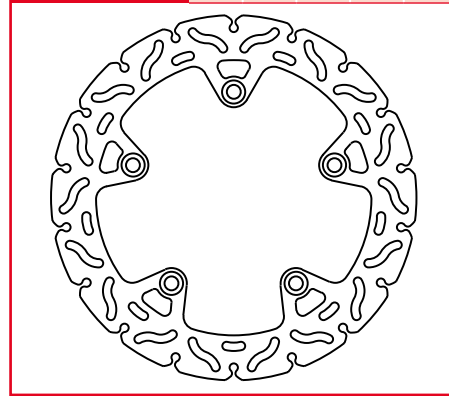

MST465RAC

A	B	C	D	E
320	210	5		230

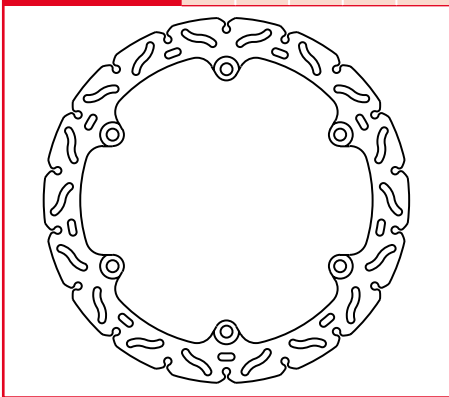

MST466

A	B	C	D	E
260	101.3	5		120

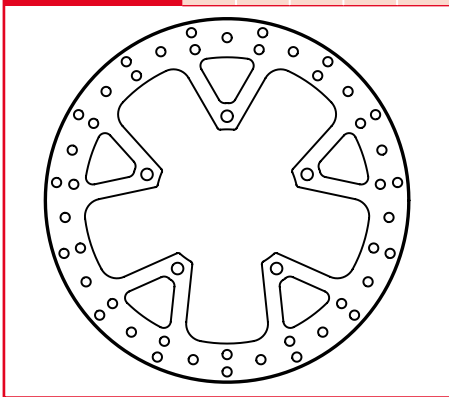

MST467RAC

A	B	C	D	E
220	81.8	5		100

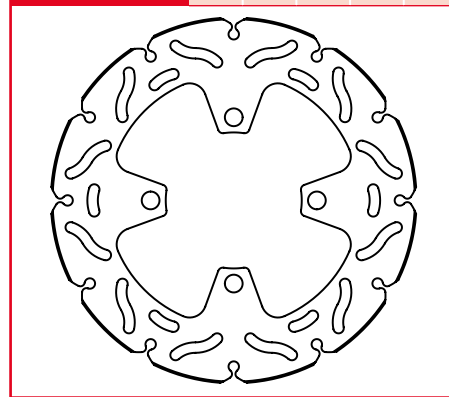



MST468

A	B	C	D	E
300	121.3	5		142

MST469

A	B	C	D	E
282	134.3	5		165

MST500

A	B	C	D	E
292	56.4	5		82.7

MST500SWL

A	B	C	D	E
292	56.4	5		82.7

MST500SWR

A	B	C	D	E
292	56.4	5		82.7

MST501

A	B	C	D	E
292	56.4	5		82.3

MST501SWL

A	B	C	D	E
292	56.4	5		82.3

MST501SWR

A	B	C	D	E
292	56.4	5		82.3

MST503

A	B	C	D	E
260	56.4	5		82.7

MST503SWL

A	B	C	D	E
260	56.4	5		82.7

MSW110

A	B	C	D	E
320	132	5		150

MSW112RAC

A	B	C	D	E
320	100	5		116



MSW113RAC

A	B	C	D	E
320	118	5		134

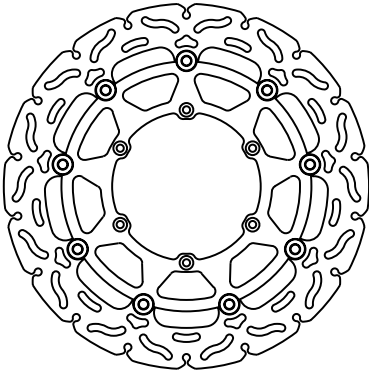

MSW114RAC

A	B	C	D	E
320	126.8	5		143

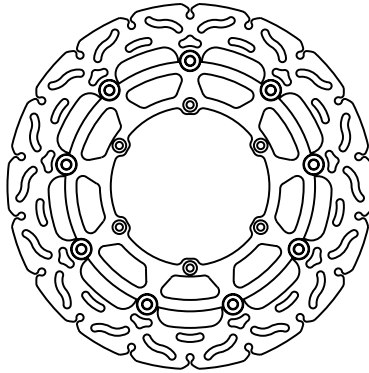

MSW115

A	B	C	D	E
320	100	5		116

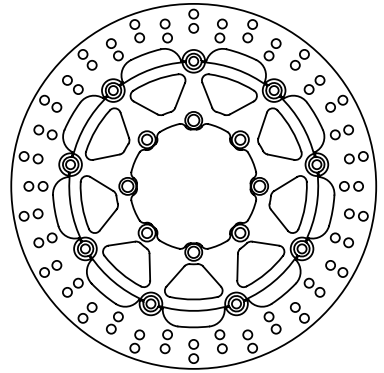

MSW118

A	B	C	D	E
320	120	5		135

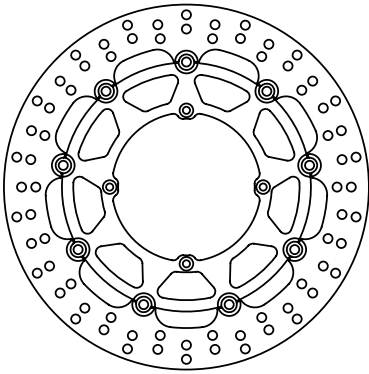

MSW119RAC

A	B	C	D	E
320	101	5		117

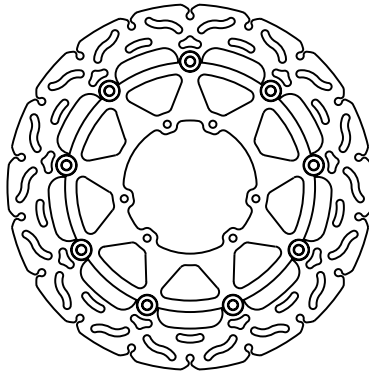

MSW120

A	B	C	D	E
320	118	5		134

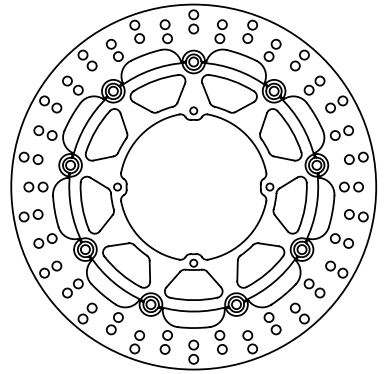

MSW200

A	B	C	D	E
305	118	5		134

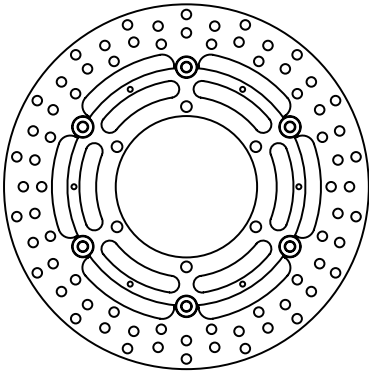

MSW201

A	B	C	D	E
320	94.2	5	12.5	110

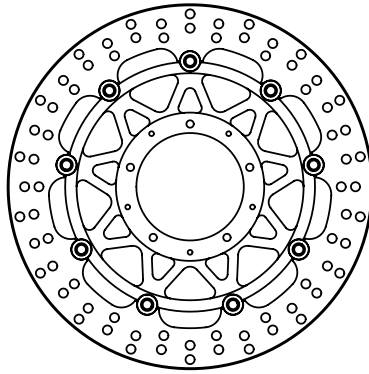

MSW202RAC

A	B	C	D	E
282	132	5		150

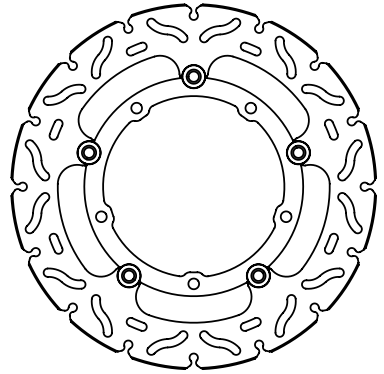

MSW203RAC

A	B	C	D	E
320	80	5		101.5

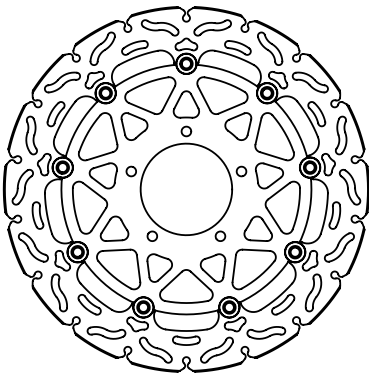

MSW203RAC-SP

A	B	C	D	E
320	80	5.5		101.5

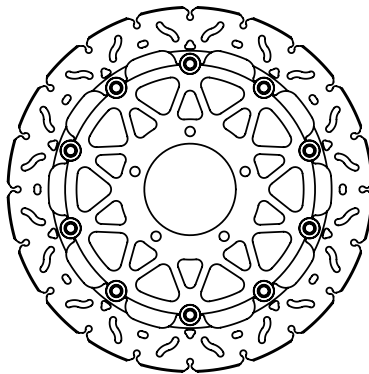

MSW203SP

A	B	C	D	E
320	80	5.5		101.5

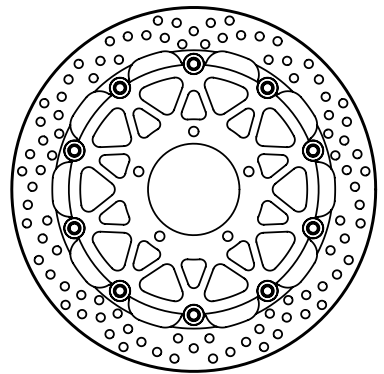



MSW204RAC	A	B	C	D	E
	320	132.2	5		150

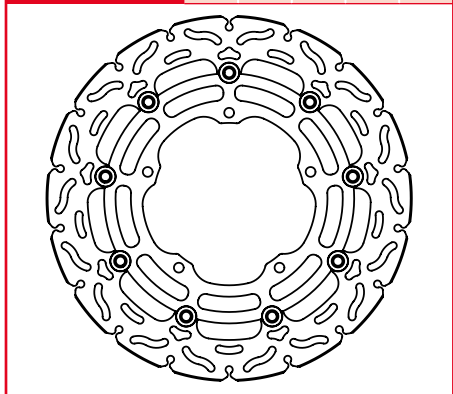

MSW204RAC-SP	A	B	C	D	E
	320	132.2	5.5		150

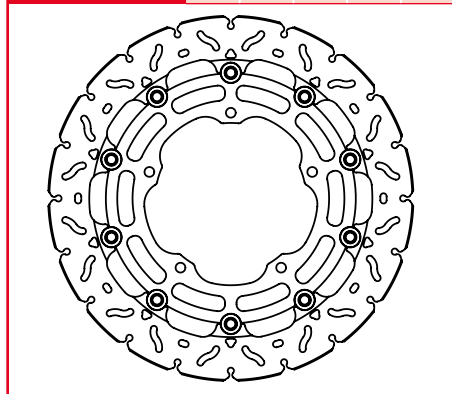

MSW204SP	A	B	C	D	E
	320	132.2	5.5		150

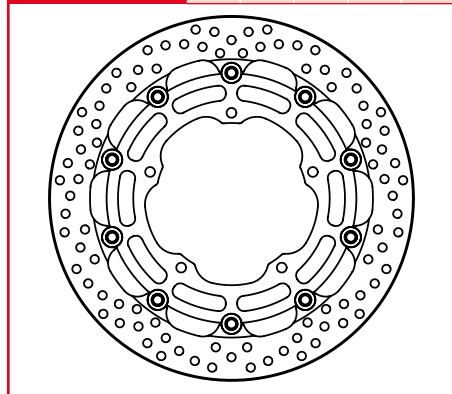

MSW205RAC	A	B	C	D	E
	320	64.2	5		80

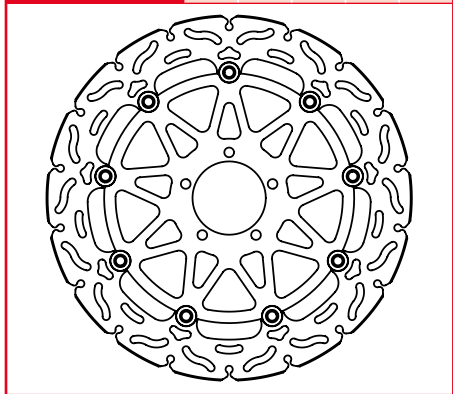

MSW206RAC-SP	A	B	C	D	E
	320	80.2	5.5		101.5

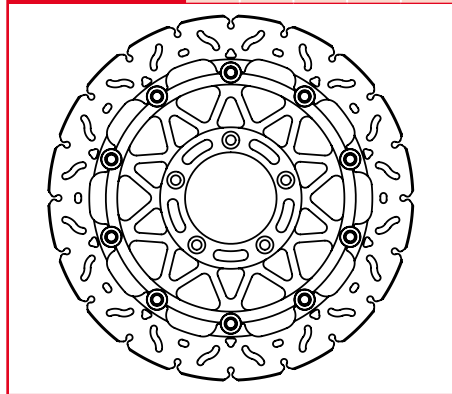

MSW206SP	A	B	C	D	E
	320	80.2	5.5		101.5

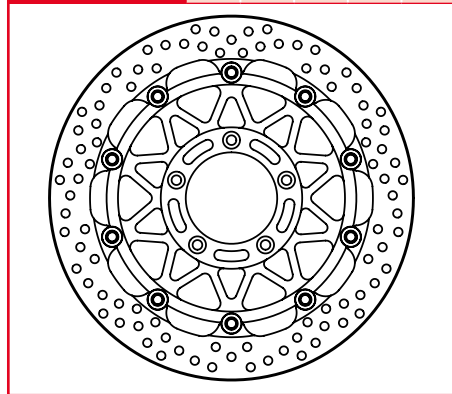

MSW207	A	B	C	D	E
	320	136.8	5		153

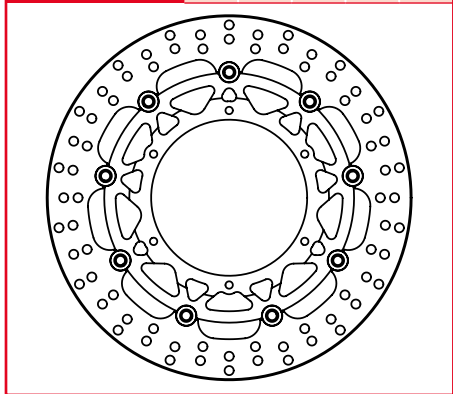

MSW209RAC	A	B	C	D	E
	310	132.3	5		150

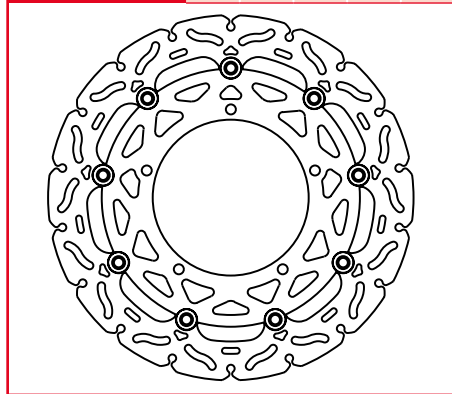

MSW210	A	B	C	D	E
	296	62	5	17.7	78

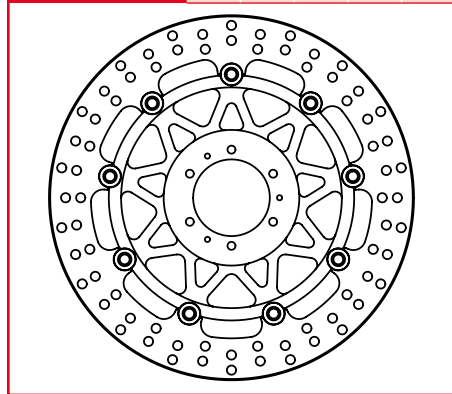

MSW211	A	B	C	D	E
	320	64	5	10	80

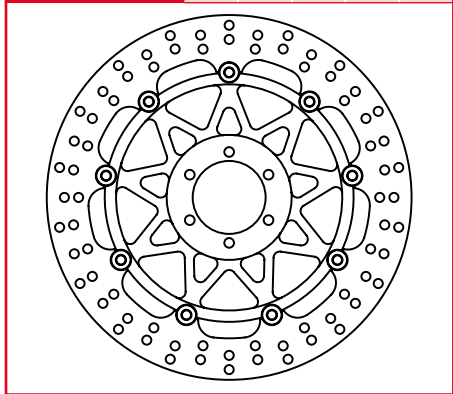

MSW211RAC	A	B	C	D	E
	320	64	5	10	80

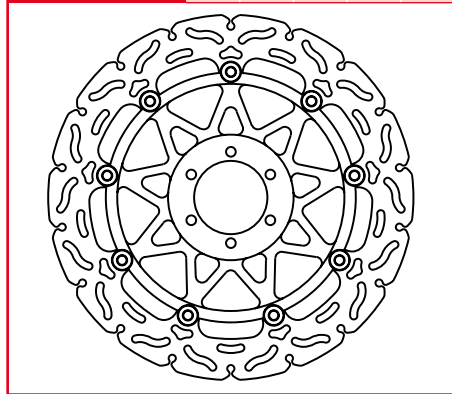

MSW212	A	B	C	D	E
	296	58	5	17	74

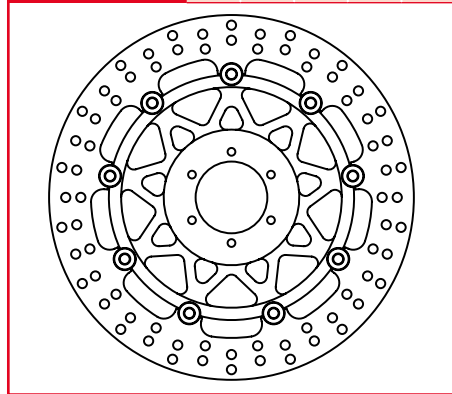



MSW212RAC

A	B	C	D	E
296	58	5	17	74

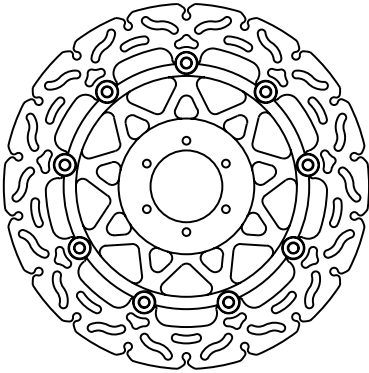

MSW214

A	B	C	D	E
310	61	5	13.5	81

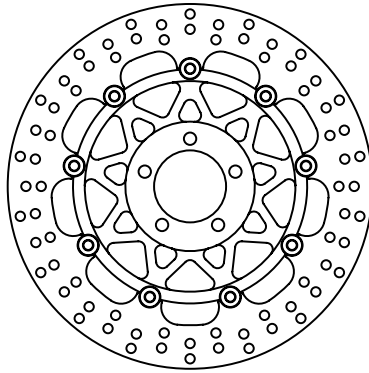

MSW214RAC

A	B	C	D	E
310	61	5	13.5	81

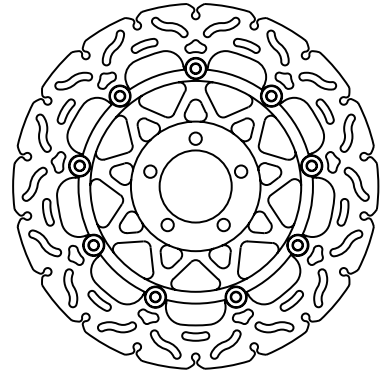

MSW215

A	B	C	D	E
300	61	5	13.5	81

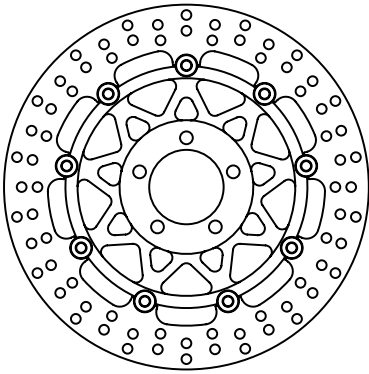

MSW215RAC

A	B	C	D	E
300	61	5	13.5	81

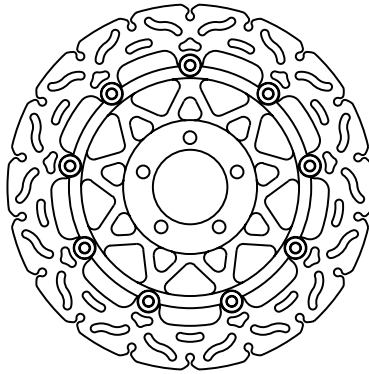

MSW216

A	B	C	D	E
320	61	5	13.5	81

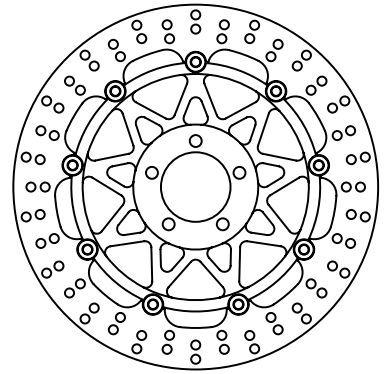

MSW216RAC

A	B	C	D	E
320	61	5	13.5	81

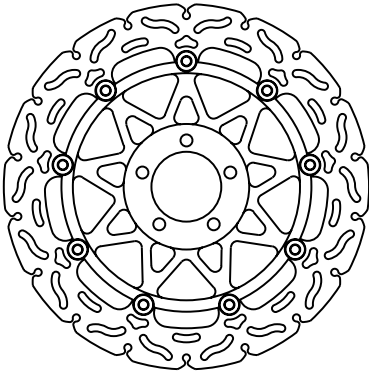

MSW217

A	B	C	D	E
310	64	5	22.5	86

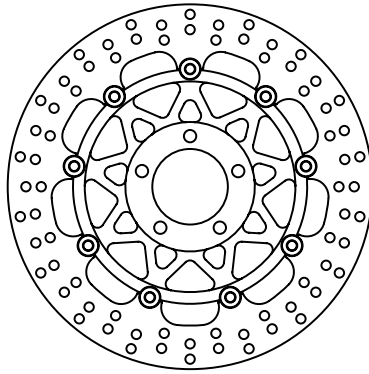

MSW217RAC

A	B	C	D	E
310	64	5	22.5	86

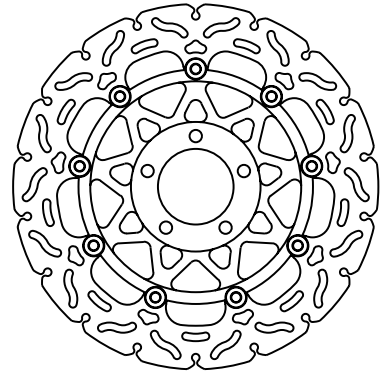

MSW218

A	B	C	D	E
300	64	5	19.5	86

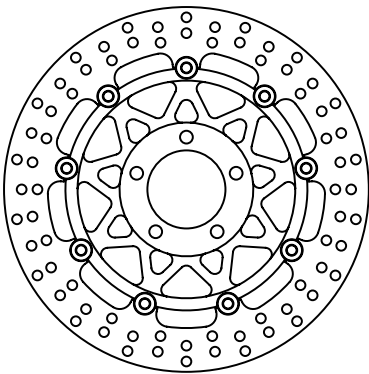

MSW219

A	B	C	D	E
310	64	5	19.5	86

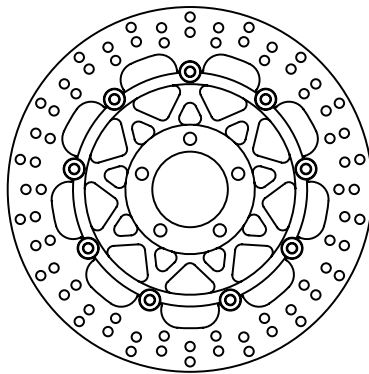

MSW219RAC

A	B	C	D	E
310	64	5	19.5	86

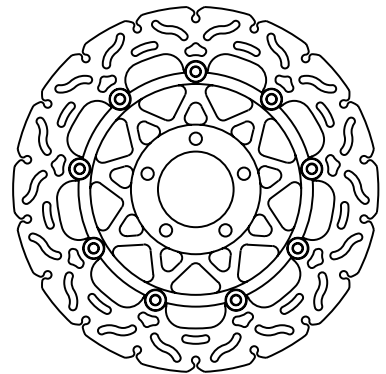



MSW220

A	B	C	D	E
290	64	5	19.5	86

MSW220RAC

A	B	C	D	E
290	64	5	19.5	86

MSW221

A	B	C	D	E
300	64	5	10	80

MSW221RAC

A	B	C	D	E
300	64	5	10	80

MSW222

A	B	C	D	E
320	64	5	10	80

MSW223

A	B	C	D	E
320	69	5		91

MSW223RAC

A	B	C	D	E
320	69	5		91

MSW224

A	B	C	D	E
300	132	5		150

MSW224RAC

A	B	C	D	E
300	132	5		150

MSW227

A	B	C	D	E
310	62	5	21.5	78

MSW228

A	B	C	D	E
296	61	5	13.5	81

MSW235

A	B	C	D	E
298	132	5		150



MSW235RAC

A	B	C	D	E

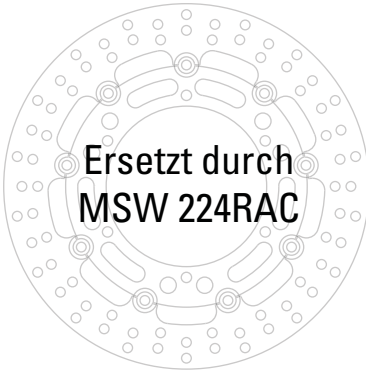

Ersetzt durch
MSW 224RAC

MSW236

A	B	C	D	E
296	62	5	17	78

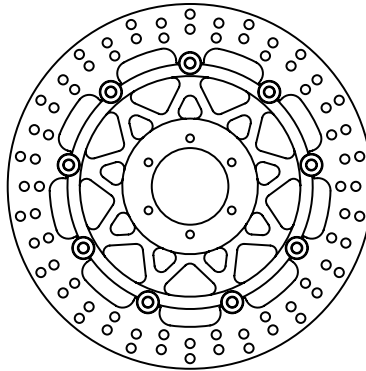

MSW238

A	B	C	D	E
280	80.5	5		100

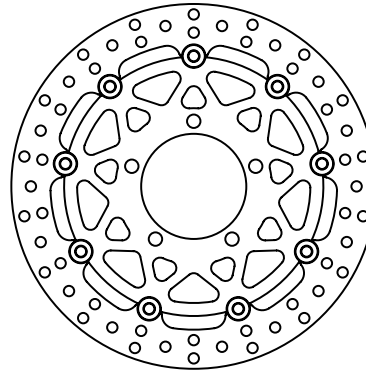

MSW240

A	B	C	D	E
310	94	5	12.5	110

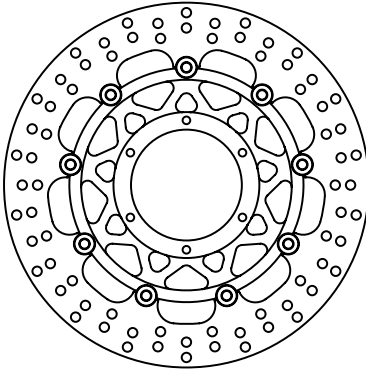

MSW240RAC

A	B	C	D	E
310	94	5	12.5	110

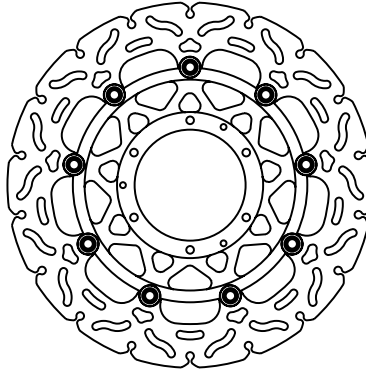

MSW240RAC-SP

A	B	C	D	E
310	94	5.5	12.5	110

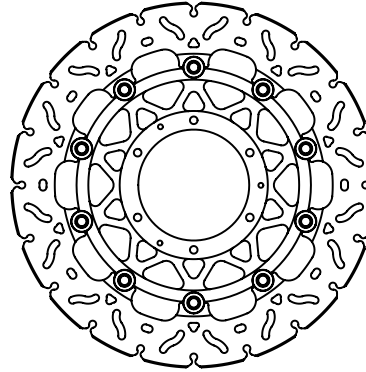

MSW240SP

A	B	C	D	E
310	94	5.5	12.5	110

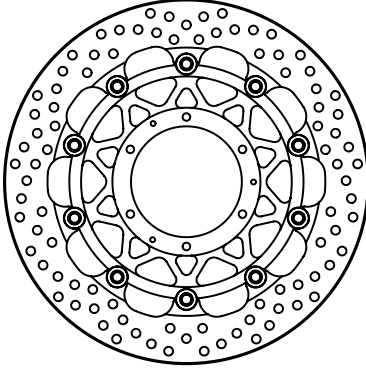

MSW241

A	B	C	D	E
300	69	5		91

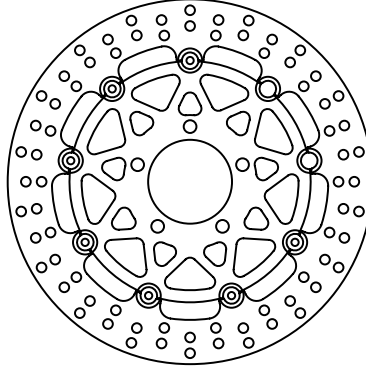

MSW241RAC

A	B	C	D	E
300	69	5		91

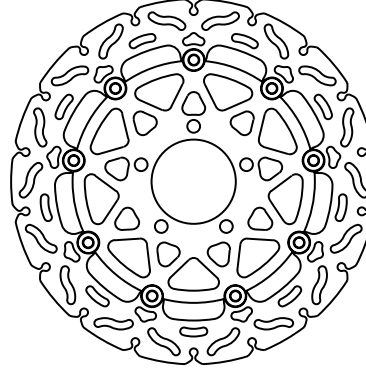

MSW242

A	B	C	D	E
310	132	5		150

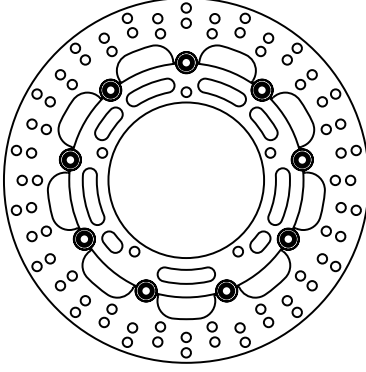

MSW242RAC

A	B	C	D	E
310	132	5		150

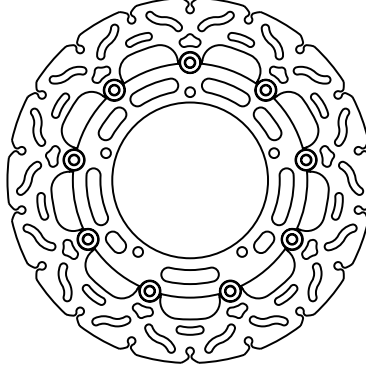

MSW242RAC-SP

A	B	C	D	E
310	132	5		150

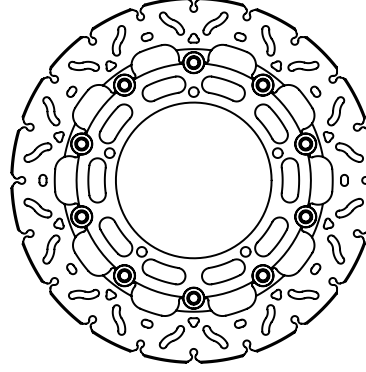



MSW242SP

A	B	C	D	E
310	132	5		150

MSW243

A	B	C	D	E
296	58	5	23	74

MSW244

A	B	C	D	E
296	94	5	12.5	110

MSW244RAC

A	B	C	D	E
296	94	5	12.5	110

MSW245

A	B	C	D	E
330	94	5	12.5	110

MSW245RAC

A	B	C	D	E
330	94	5	12.5	110

MSW246

A	B	C	D	E
298	132	5		150

MSW246RAC

A	B	C	D	E
300	132	5		150

MSW247

A	B	C	D	E
320	132	5		150

MSW247RAC

A	B	C	D	E
320	132	5		150

MSW248

A	B	C	D	E
290	69	5		91

MSW248RAC

A	B	C	D	E
290	69	5		91



MSW250	A	B	C	D	E
	310	69	5		91

MSW250RAC	A	B	C	D	E
	310	69	5		91

MSW251	A	B	C	D	E
	320	78	5	10.5	100.5

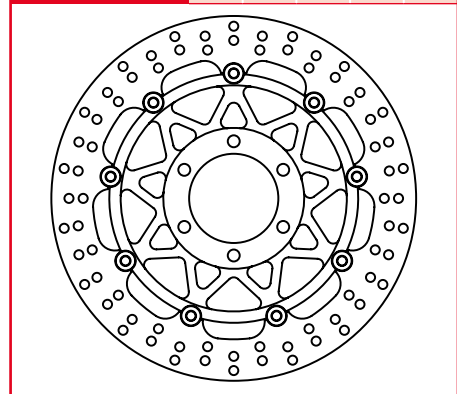
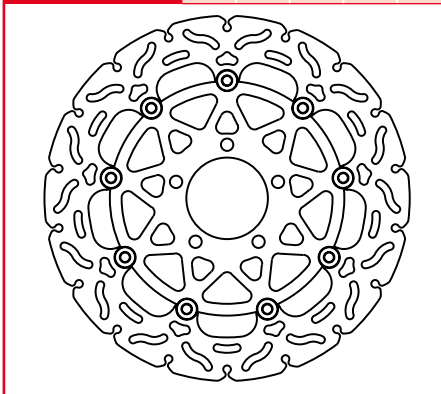
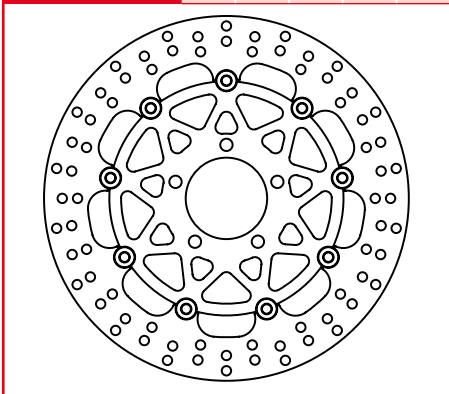

MSW253	A	B	C	D	E
	300	105.3	5		120

MSW254	A	B	C	D	E
	320	94	5	12.5	110

MSW254RAC	A	B	C	D	E
	320	94	5	12.5	110

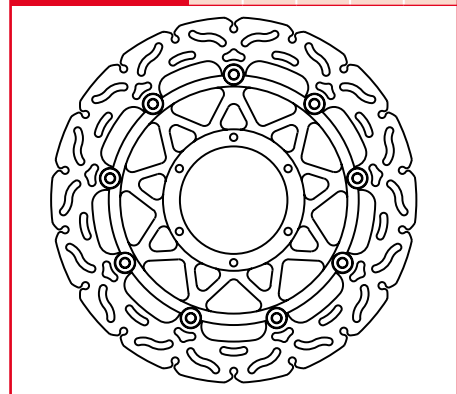
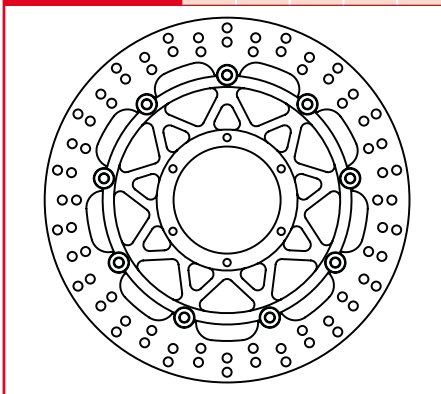
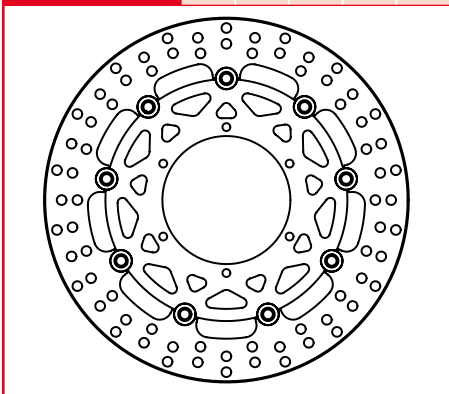

MSW255RAC	A	B	C	D	E
	310	100	5		120

MSW257RAC	A	B	C	D	E
	300	80	5		100

MSW257RAC-SP	A	B	C	D	E
	300	80	5.5		100

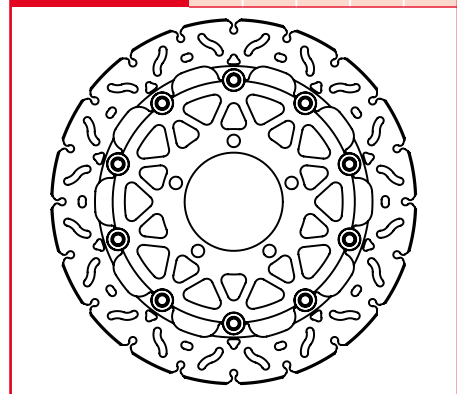
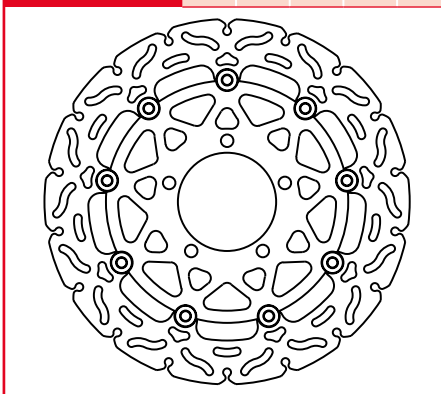
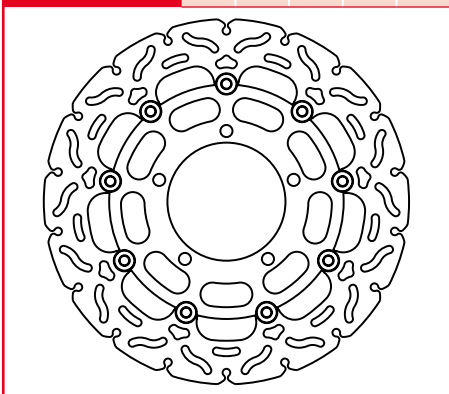

MSW257SP	A	B	C	D	E
	300	80	5.5		100

MSW258RAC	A	B	C	D	E
	310	62	5	18.5	78

MSW259	A	B	C	D	E
	310	121.5	5		142

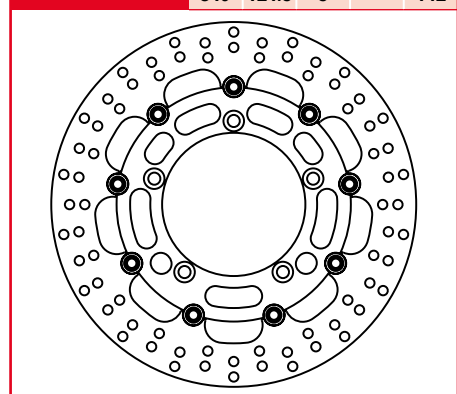
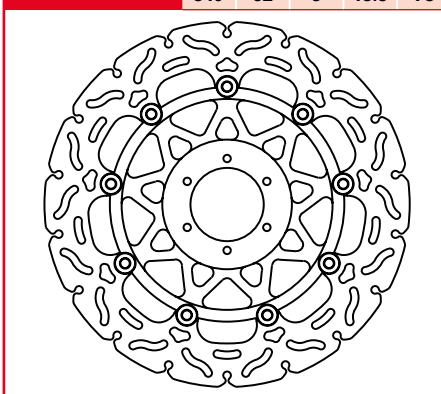
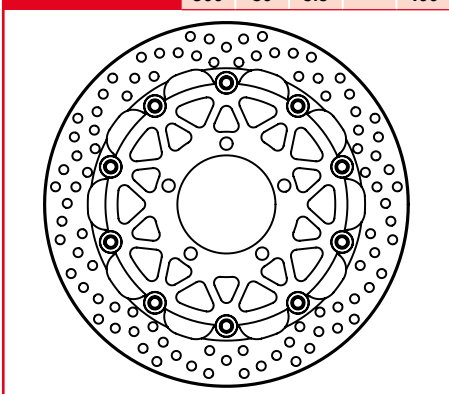



MSW259RAC	A	B	C	D	E
	310	121.5	5		142

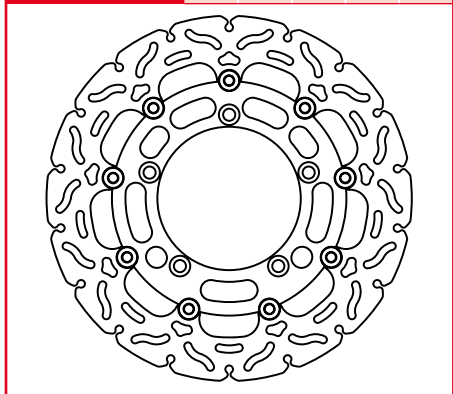

MSW260RAC	A	B	C	D	E
	290	121.5	5		142

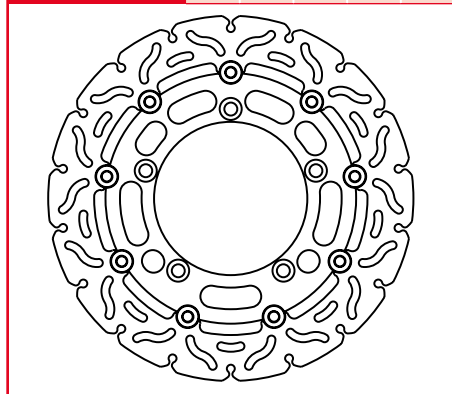

MSW261RAC	A	B	C	D	E
	310	84.5	5	14.5	100.5

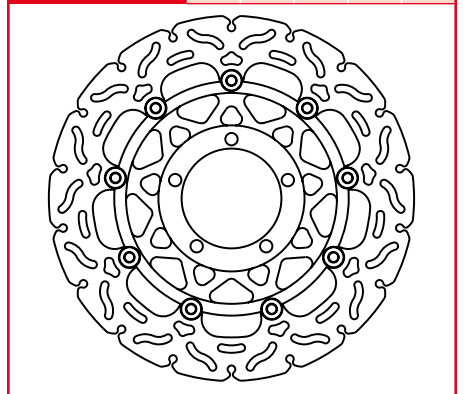

MSW262RAC	A	B	C	D	E
	320	132	5		150

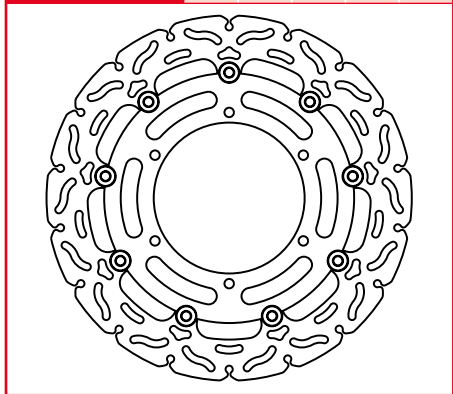

MSW264RAC	A	B	C	D	E
	310	80.5	5		100

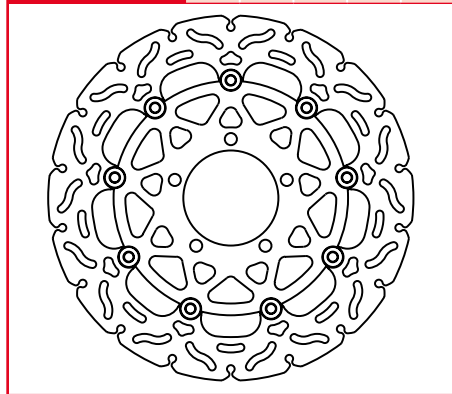

MSW264RAC-SP	A	B	C	D	E
	310	80.5	5.5		100

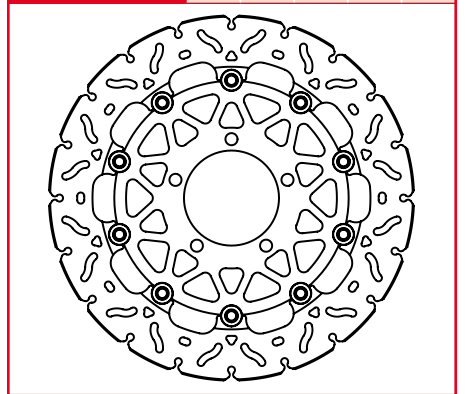

MSW264SP	A	B	C	D	E
	310	80.5	5.5		100

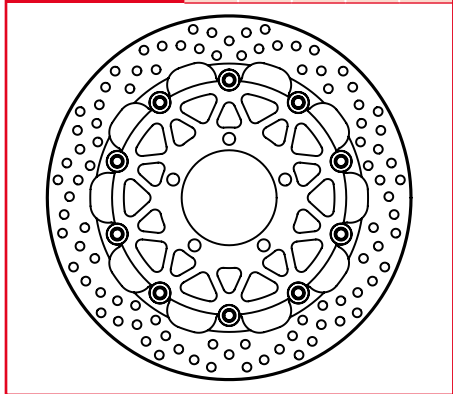

MSW265RAC	A	B	C	D	E
	320	94	5	15.25	110

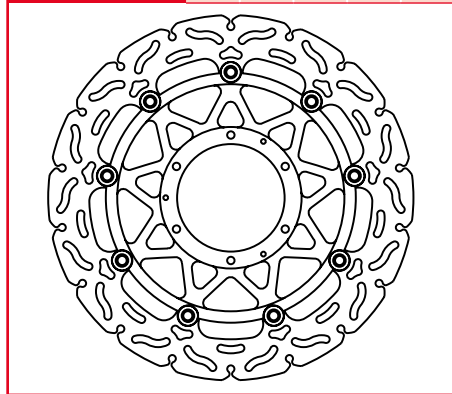

MSW265RAC-SP	A	B	C	D	E
	320	94	5.5	15.25	110

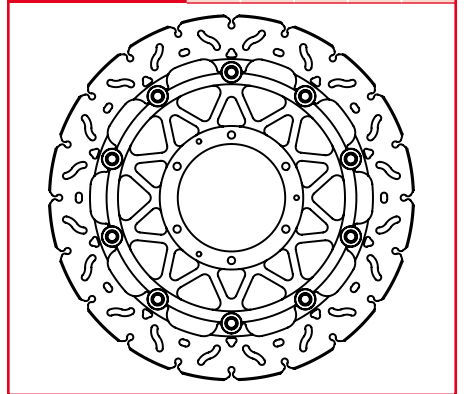

MSW265SP	A	B	C	D	E
	320	94	5.5	15.25	110

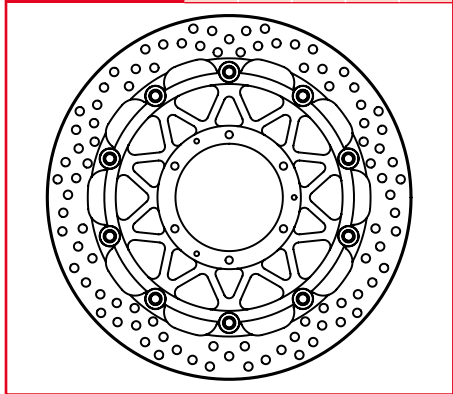

MSW266RAC	A	B	C	D	E
	310	102	5		120

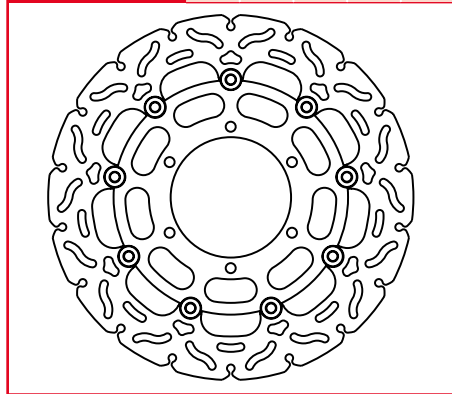

MSW266RAC-SP	A	B	C	D	E
	310	102	5.5		120

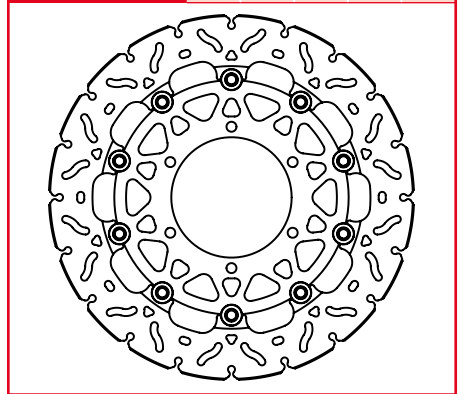



MSW266SP

A	B	C	D	E
310	102	5.5		120

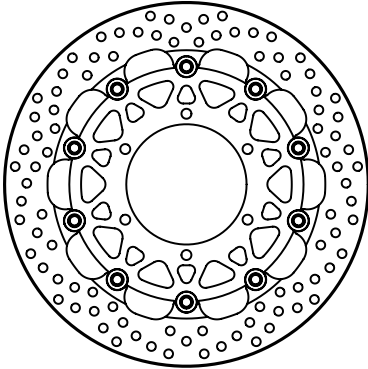

MSW267RAC

A	B	C	D	E
320	72	5	15	90

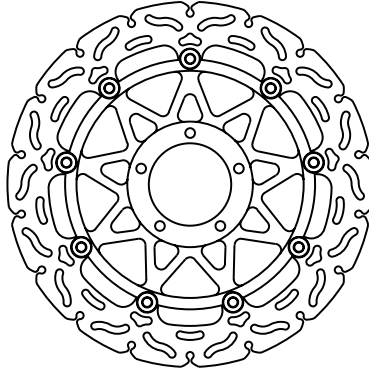

MSW267RAC-SP

A	B	C	D	E
320	72	5.5	15	90

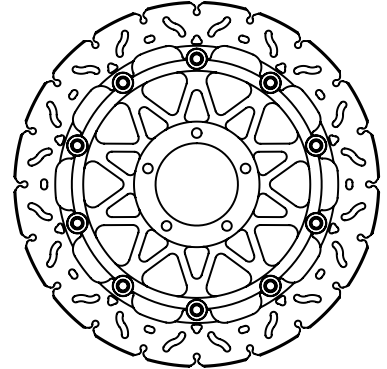

MSW267SP

A	B	C	D	E
320	72	5.5	15	90

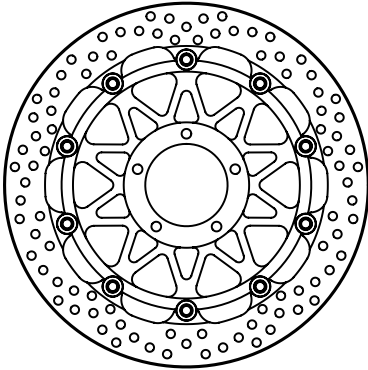

MSW268

A	B	C	D	E
267	132	4		150

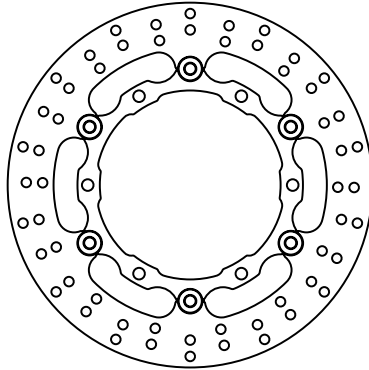

MSW269

A	B	C	D	E
267	132	4		150

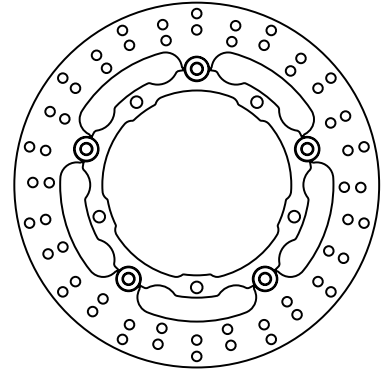

MSW270RAC

A	B	C	D	E
320	105	5		120

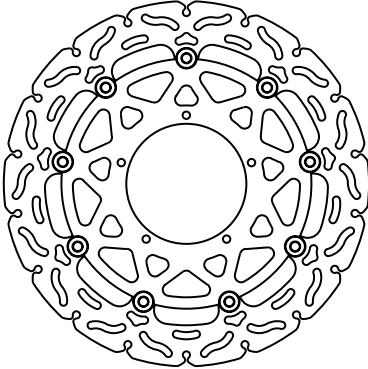

MSW271

A	B	C	D	E
320	132	5	15	150

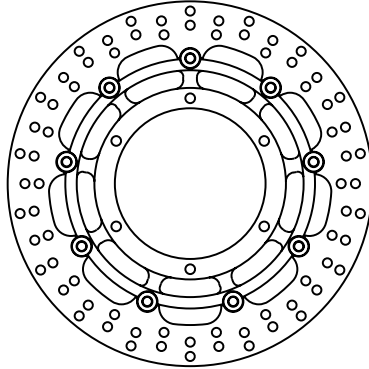

MSW272

A	B	C	D	E
296	94	5	17.5	110

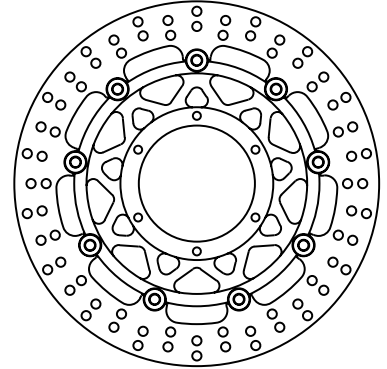

MSW273RAC

A	B	C	D	E
310	132	5		150

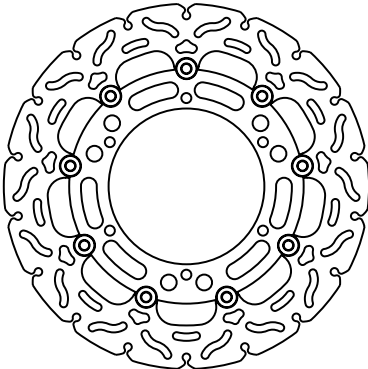

MSW274RAC

A	B	C	D	E
300	80.5	5		100

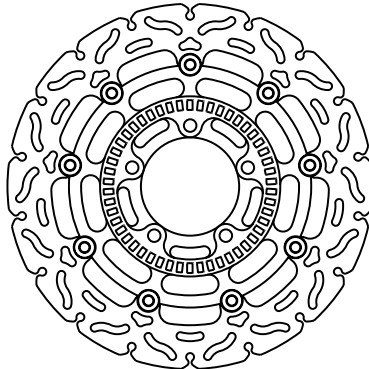

MSW276

A	B	C	D	E
320	105	5		166





MSW277RAC	A	B	C	D	E
	300	126	5		228

MSW278	A	B	C	D	E
	320	78	5	17.5	100

MSW280RAC	A	B	C	D	E
	330	72	5	15	90

MSW280RAC-SP	A	B	C	D	E
	330	72	5.5	15	90

MSW280SP	A	B	C	D	E
	330	72	5.5	15	90

MSW281RAC	A	B	C	D	E
	305	72	5	10	90

MSW282RAC	A	B	C	D	E
	305	64	5	10	80

MSW283RAC	A	B	C	D	E
	296	94	5	14.5	110

MSW284	A	B	C	D	E
	310	94	5	21.5	110

MSW285RAC	A	B	C	D	E
	320	72.2	5	10	90

MSW286	A	B	C	D	E
	305	84.7	5		100

MSW287RAC	A	B	C	D	E
	310	82.7	5	5	100.5



MSW287RAC-SP

A	B	C	D	E
310	82.7	5.5	5	100.5

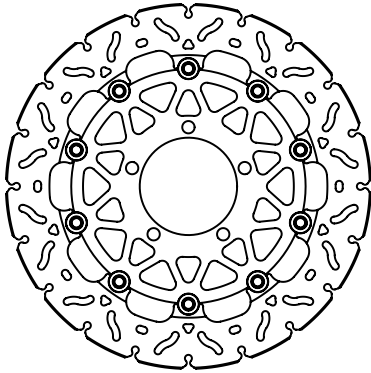

MSW287SP

A	B	C	D	E
310	82.7	5.5	5	100.5

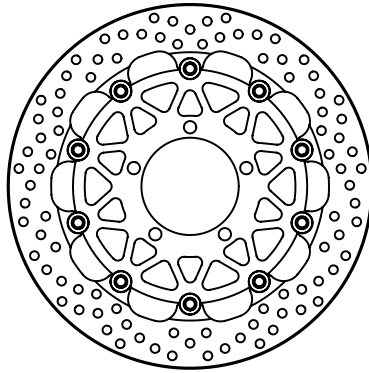

MSW288RAC

A	B	C	D	E
320	64.2	5	5	80

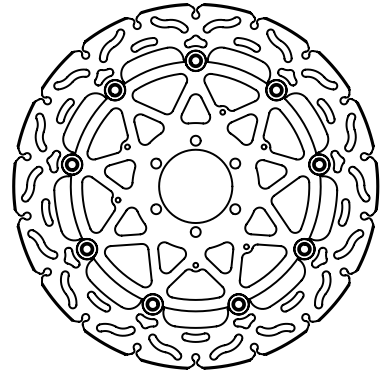

MSW288SP-L

A	B	C	D	E
320	64.2	5.5	5	80

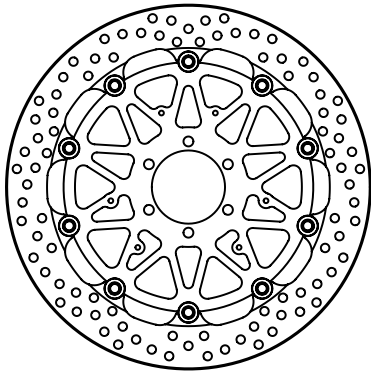

MSW288SP-R

A	B	C	D	E
320	64.2	5.5	5	80

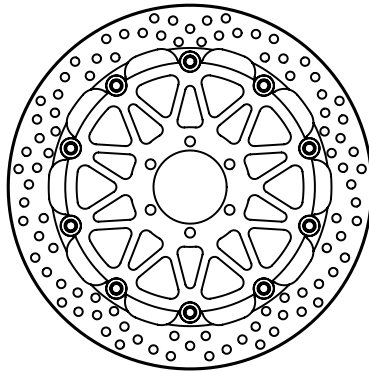

MSW289RAC

A	B	C	D	E
320	52.2	5	5	80

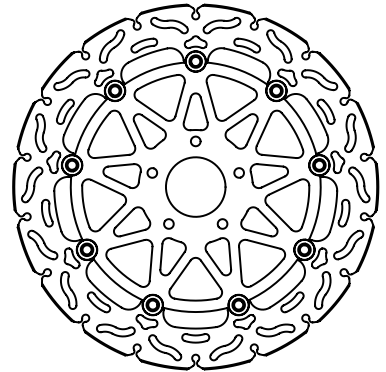

MSW357RAC-SP

A	B	C	D	E
320	181	5.5		202.5

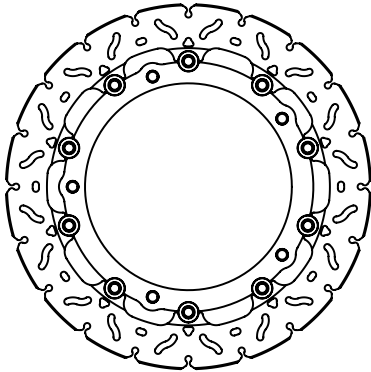

MSW357SP

A	B	C	D	E
320	181	5.5		202.5

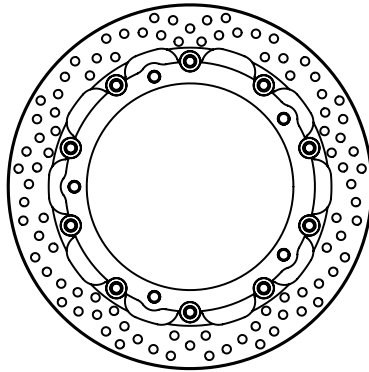



STAHLFLEXBREMSLEITUNGEN

DURITES DE FREINS RENFORCÉES

STEEL-BRAIDED BRAKE HOSES

STAHLFLEXBREMSLEITUNGEN

DURITES DE FREINS RENFORCÉES STEEL-BRAIDED BRAKE HOSES

- » TRW Stahlflexleitungen verbessern den Druckpunkt deutlich, sind wartungsfrei und ermöglichen ein längeres Wechselintervall bei der Bremsflüssigkeit.
- » TRW Stahlflexleitungen entsprechen der internationalen DIN Norm FMVSS106. Die Innenseele ist aus Teflon und das Stahlgewebe vieradrig.
- » *TRW steel-braided brake hoses significantly improve the pressure point, they are maintenance-free and allow a longer change interval for brake fluid.*
- » *TRW steel-braided hoses comply with the international DIN standard FMVSS106. The inner core is made from Teflon and the steel fabric has four wires.*
- » *Les durites de frein renforcées TRW améliorent nettement le point de poussée, ne nécessitent aucun entretien et permettent des intervalles de remplacement plus longs pour le liquide de frein.*
- » *Les durites de frein renforcées TRW satisfont à la norme internationale DIN FMVSS 106. Le noyau intérieur est fabriqué en Teflon et le treillis en acier est doté de quatre fils.*

VARIOFLEXLEITUNGEN MIT TÜV

DURITES DES FREINS RENFORCÉES VARIOFLEX AVEC HOMOLOGATION TÜV

VARIOFLEX LINES WITH TÜV



Verpresste Stahlflexleitungen mit individuell einschraubbaren Anschlüssen

- » Varioflexleitungen können selbst konfektioniert werden
- » Anschlüsse und Leitungen bitte getrennt bestellen
- » hohe Flexibilität in der Lagerhaltung
- » Anschlüsse aus Aluminium oder Edelstahl
- » **Leitungen sind entweder transparent (T) oder schwarz (S) ummantelt**
- » Längen in 3 cm-Schritten von 1 bis 200 cm erhältlich
- » Hohlschrauben und Dichtringe siehe Seite 3.7 und 3.9
- » individuelle Befestigungsteile siehe Seite 3.9

Pressed steel-braided brake hoses with individual screw-in connectors

- » *Varioflex hoses can be assembled by the customer*
- » *please order connectors and hoses separately*
- » *highly flexible storage*
- » *aluminium or stainless steel connectors*
- » **hoses have either transparent (T) or black (S) cover**
- » *available lengths from 1 to 200 cm in 3 cm increments*
- » *banjo bolts and seals see p. 3.7 and 3.9*
- » *individual attachment parts see p. 3.9*

Durites de frein renforcée avec raccords filetés individuels

- » *les durites Varioflex peuvent être confectionnés sur site*
- » *veuillez commander les raccords et durites séparément*
- » *grande flexibilité pour la gestion des stocks*
- » *raccords en aluminium ou acier inoxydable*
- » **flexibles avec gaines transparentes (T) ou noires (N)**
- » *longueurs disponibles par pas de 3 cm, de 1 à 200 cm*
- » *vis à tête creuse et bagues d'étanchéité cf. pg. 3.7 et 3.9*
- » *pièces de fixation individuelles cf. pg. 3.9*

Ummantelung | Cover | Gaine de protection

S = Schwarz | black | noir

T = Transparent | transparent | transparente



Bitte Farbe „S“ oder „T“ ergänzen.

Bestellbeispiele: MV033S = Ummantelung schwarz

MV033T = Ummantelung transparent

Please indicate colour "S" or "T".

Ordering examples: MV033S = black cover

MV033T = transparent cover

Veillez ajouter «S» ou «T» pour la couleur.

Exemples de commande: MV033S = gaine noire

MV033T = gaine transparente

Leitungen | Lines | Durites

Länge Length Longueur	Bestell-Nr. Order no. N° comm.	Länge Length Longueur	Bestell-Nr. Order no. N° comm.
13 cm	MV013...	99 cm	MV099...
15 cm	MV015...	102 cm	MV102...
18 cm	MV018...	105 cm	MV105...
21 cm	MV021...	108 cm	MV108...
23 cm	MV023...	110 cm	MV110...
25 cm	MV025...	113 cm	MV113...
27 cm	MV027...	115 cm	MV115...
29 cm	MV029...	118 cm	MV118...
31 cm	MV031...	120 cm	MV120...
33 cm	MV033...	123 cm	MV123...
35 cm	MV035...	126 cm	MV126...
37 cm	MV037...	129 cm	MV129...
39 cm	MV039...	131 cm	MV131...
41 cm	MV041...	134 cm	MV134...
43 cm	MV043...	137 cm	MV137...
45 cm	MV045...	140 cm	MV140...
47 cm	MV047...	143 cm	MV143...
49 cm	MV049...	146 cm	MV146...
51 cm	MV051...	149 cm	MV149...
53 cm	MV053...	152 cm	MV152...
55 cm	MV055...	155 cm	MV155...
57 cm	MV057...	158 cm	MV158...
60 cm	MV060...	161 cm	MV161...
63 cm	MV063...	165 cm	MV165...
66 cm	MV066...	167 cm	MV167...
69 cm	MV069...	170 cm	MV170...
72 cm	MV072...	174 cm	MV174...
75 cm	MV075...	177 cm	MV177...
78 cm	MV078...	181 cm	MV181...
81 cm	MV081...	185 cm	MV185...
84 cm	MV084...	189 cm	MV189...
87 cm	MV087...	193 cm	MV193...
90 cm	MV090...	197 cm	MV197...
93 cm	MV093...	200 cm	MV200...
96 cm	MV096...		

ACHTUNG! ATTENTION! ATTENTION!

Zur Komplettierung einer Bremsleitung bitte Anschlüsse (s. Seite 3.4 – 3.5), Leitungen und Dichtringe (s. Seite 3.9) separat bestellen!

To complete the brake line, please order connectors (see pg. 3.4 – 3.5) lines and seals (see pg. 3.9) separately!

Pour commander une durite de frein complète, veuillez commander les raccords (cf. page 3.4 – 3.5), les durites et les bagues d'étanchéité (cf. page 3.9) séparément !

Verdrehbare Anschlüsse!

Twistable connections!

Raccordements souples!

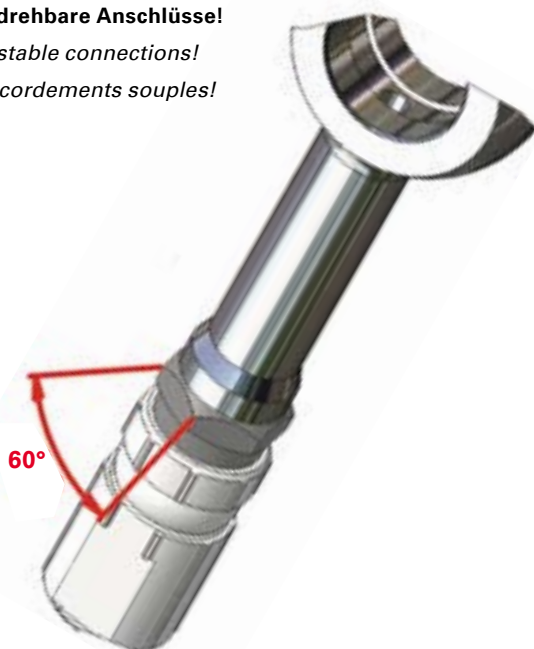

MV 10A00

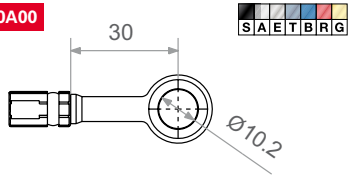

MV 10B20

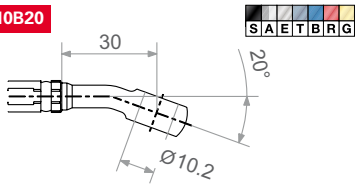

MV 10B30

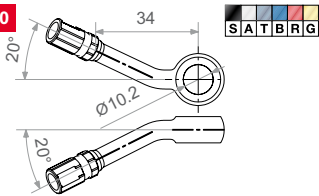

MV 10E20

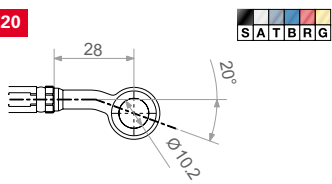

MV 10C45

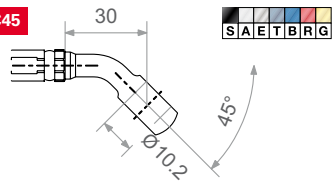

MV 10D50

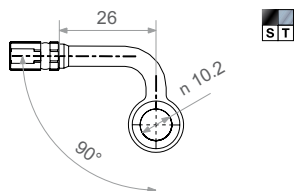

MV 11D90

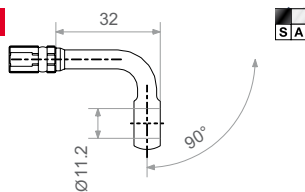

MV 10D70

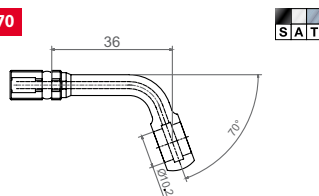

MV 11A00

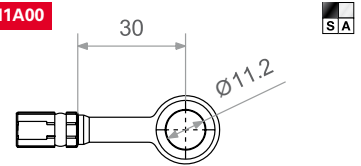

MV 11B20

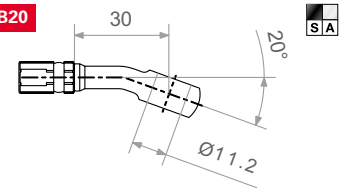

MV 10B40

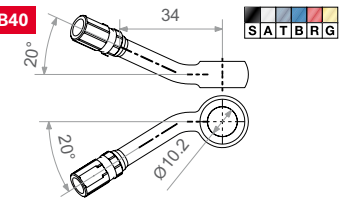

MV 10E40

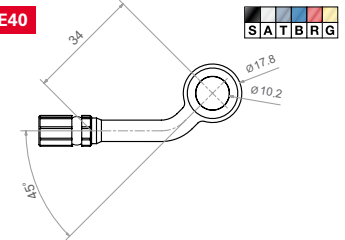

MV 11C45

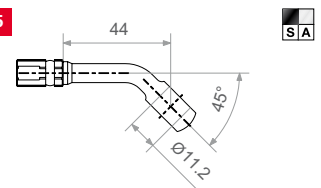

MV 10D90

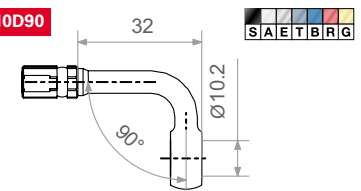

MV 10K00

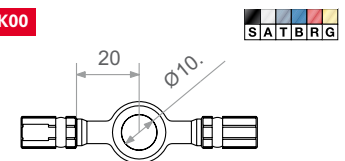

Zur Komplettierung der Bremsleitung bitte Anschlüsse separat bestellen!

To complete the brake line, please order connectors separately!

Pour commander une durite complète, veuillez commander les raccords séparément.

Bitte gewünschte Farbe ergänzen:

Please indicate required colour:
Veuillez indiquer la couleur souhaitée:

- S = Schwarz, black, noir
- A = Silber, argent
- E = Edelstahl, stainless steel, inox
- T = Titan, titanium, titane
- B = Blau, blue, bleu
- R = Rot, red, rouge
- G = Gold, gold, aurifère

MV 10KA1

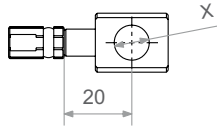

MVF 225
M10x1.25

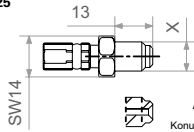

Aussengewinde fest
Konus 90° = Konvex+Konkav

MVF 900
M10x1.00

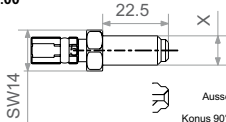

Aussengewinde fest
Konus 90° = Konvex+Konkav

MVG 100 | **MVG 225** | **MVG 38**
M10x1.00 | M10x1.25 | 3/8"-24 UNF

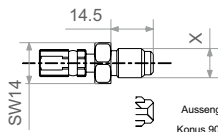

Aussengewinde beweglich
Konus 90° = Konvex+Konkav

MVH 400
M10x1.00

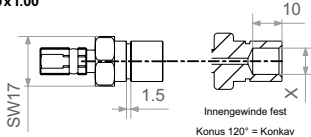

Innengewinde fest
Konus 120° = Konkav

MV 988

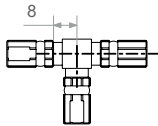

3-Weg Verteiler

Bitte gewünschte Farbe ergänzen:

Please indicate required colour:
Veillez indiquer la couleur souhaitée:

- S = Schwarz,**
black, noir
- A = Silber,**
argent
- E = Edelstahl,**
stainless steel,
inox
- T = Titan,**
titanium, titane
- B = Blau,**
blue, bleu
- R = Rot,**
red, rouge
- G = Gold,**
gold, aurifère

MVF 100
M10x1.00

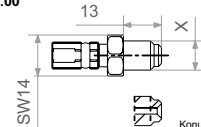

Aussengewinde fest
Konus 90° = Konvex+Konkav

MVF 400
M10x1.00

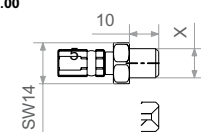

Aussengewinde fest
Konus 90° = Konkav

MV 908
M5x0.5

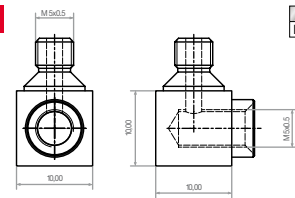

MVH 100 | **MVH 225**
M10x1.00 | M10x1.25

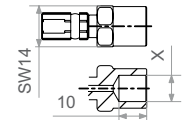

Innengewinde fest
Konus 120° = Konkav

MVJ 100 | **MVJ 225**
M10x1.00 | M10x1.25

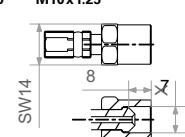

Innengewinde beweglich
Konus 90° = Konvex

MV 989

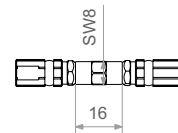

Kupplung Vario

Musterabbildung Leitung, 36 cm Länge

Sample image of a line, 36 cm long
Illustration d'un modèle de durite, longueur: 36 cm

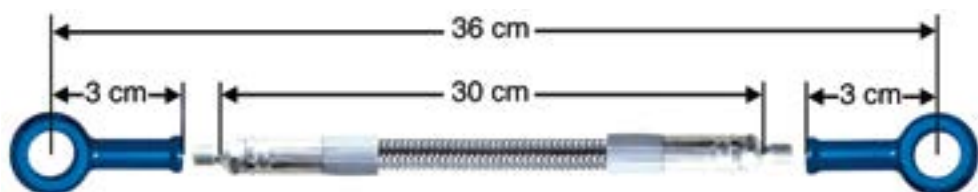

STAHLFLEXLEITUNGEN MIT ABE

DURITES DE FREINS RENFORCÉES AVEC HOMOLOGATION TÜV
STEEL-BRAIDED HOSES, TÜV APPROVED

Lieferung fertig konfektioniert

Delivered ready-to-use

Livraison prêt à l'emploi



Fahrzeugspezifische, einbaufertige Stahlflexleitungen

- » über 1100 fertige Leitungssätze, größtenteils mit ABE
- » viele ABS-Modelle jetzt auch mit ABE
- » **alle Leitungen serienmäßig mit transparenter Ummantelung**
- » Aluminium-Anschlüsse standardmäßig in Farbe **Titan**
- » **ohne Aufpreis** sind andersfarbige Anschlüsse und Ummantelungen möglich
- » auf Wunsch sind auch andere Sonderanfertigungen erhältlich
- » Verwendung der original Hohlschrauben ist ebenfalls möglich
- » Aluminium-Dichtringe sind im Lieferumfang enthalten

Vehicle-specific, ready-to-install steel-braided hoses

- » *more than 1100 ready-to-use hose sets, mostly with TÜV approval*
- » *many ABS models now available*
- » **all hoses with transparent cover as a standard**
- » *aluminium connectors as a standard in **titanium** colour*
- » *connectors and covers in other colours are available **without surcharge***
- » *other customised versions are also available on request*
- » *original banjo bolts can also be used*
- » *aluminium seals are included in the scope of delivery*

Durites de frein renforcées prêtes à l'emploi, spécifiques aux véhicules

- » *plus de 1100 kits de durites, le plus souvent avec homologation TÜV*
- » *nombreux modèles ABS disponible*
- » **toutes les durites sont fournies de série avec une gaine transparente**
- » *raccords en aluminium de série, **titane***
- » *Des raccords et gaines de couleur sont disponibles **sans suppléments***
- » *D'autres modèles spéciaux sont également disponibles sur demande.*
- » *L'utilisation de vis à tête creuse d'origine est également possible.*
- » *Bagues d'étanchéité en aluminium fournies*

Ummantelung Cover Gaine de protection	Standard serienmäßig Standard Standard de série	Anschluss Connection Raccord
---	---	------------------------------------

Transparent | transparent
transparente



Titan | titanium
titane

Beispiele Sonderanfertigungen | Examples of custom-made versions | Exemples de modèles spéciaux

Schwarz | black | noir



Gold | gold | aurifère

Carbon | carbon | carbone



Rot | red | rouge

Blau | blue | bleu



Silber | silver | argent

Weiß | white | blanc

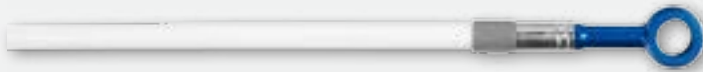

Blau | blue | bleu

Rot | red | rouge



Schwarz | black | noir

Orange | orange | orange



Silber | silver | argent

Farben | Colours | Couleurs

S schwarz
black
noir

A Silber
silver
argent

C Stahl
steel
acier

T Titan
titanium
titane

B Blau
blue
bleu

R Rot
red
rouge

G Gold
gold
aurifère

Bitte gewünschte Farbe ergänzen:
Please indicate required colour:
Veuillez indiquer la couleur souhaitée:

MCH901S

↳ S = Schwarz | black | noir

Hohlschrauben | Banjo bolts | Vis à tête creuse

Abbildung (Beispiel) Image (example) Illustration (exemple)	Bestell-Nr. Order no. N° comm.	Farbcodes Colour codes Codes couleur	Gewinde Thread Filettage
	MCH901...	S, A, C, T, B, R, G	M10 x 1,25
	MCH911...	S, A, C, T, B, R, G	M10 x 1,0 Brembo
	MCH921...	S, A, C, T, B, R, G	M10 x 1,0
	MCH931...	C	3/8" UNF
	MCH941...	C	7/16" UNF
	MCH951...	S, A, C, T, B, R, G	M10 x 1,25
	MCH961...	S, A, C, T, B, R, G	M10 x 1,0 Brembo
	MCH971...	S, A, C, T, B, R, G	M10 x 1,0

Anschlüsse Bremsleitungen Brake hose connectors Raccords pour durites de frein				
A (0°)	B (20°)	B3 (30°)	B4 (30°)	B5 (45°)
Ringanschluss Banjo Joint de raccordement A Ø 10 mm A Ø 11 mm	Ringanschluss Banjo Joint de raccordement B Ø 10 mm B Ø 11 mm	Ringanschluss Banjo Joint de raccordement B3 Ø 10 mm	Ringanschluss Banjo Joint de raccordement B4 Ø 10 mm	Ringanschluss Banjo Joint de raccordement B5 Ø 10 mm
B6 (45°)	C (45°)	D (90°), D6 (60°), D7 (70°)	D5 (90°)	E (20°)
Ringanschluss Banjo Joint de raccordement B6 Ø 10 mm	Ringanschluss Banjo Joint de raccordement C Ø 10 mm C Ø 11 mm	Ringanschluss Banjo Joint de raccordement D Ø 10 mm D6 Ø 10 mm D7 Ø 10 mm D Ø 11 mm	Ringanschluss Banjo Joint de raccordement D5 Ø 10 mm	Ringanschluss Banjo Joint de raccordement E Ø 10 mm
E4 (40°)	F1, F2	F4	F5, F6	G1, G2, G3
Ringanschluss Banjo Joint de raccordement E4 Ø 10 mm	Außengewinde, fest External thread, fixed Filettage externe serré F1 M10 x 1.00 Brembo F2 M10 x 1.25	Außengewinde, fest External thread, fixed Filettage externe serré F4 M10 x 1.00 Suzuki	Außengewinde, fest External thread, fixed Filettage externe serré F5 M10 x 1.00 F6 3/8" UNF	Außengewinde, lose External thread, swivel Filettage externe desserré G1 M10 x 1.00 G2 M10 x 1.25 G3 3/8" UNF
G90	H1, H2	J1, J2	KH1	
Außengewinde, lose External thread, swivel Filettage externe desserré G90 M10 x 1.00	Innengewinde, fest Internal thread, fixed Filettage interne serré H1 M10 x 1.00 * H2 M10 x 1.25 *	Innengewinde, lose Internal thread, swivel Filettage interne desserré J1 M10 x 1.00 ** J2 M10 x 1.25 **	Innengewinde, fest Internal thread, fixed Filettage interne serré KH1 M10 x 1.00 *	
K	K2	K3		
Ringanschluss doppelt Double connection banjo Joint de raccordement double K Ø 10 mm	Ringanschluss doppelt Double connection banjo Joint de raccordement double K2 Ø 10 mm	Ringanschluss doppelt Double connection banjo Joint de raccordement double K3 Ø 10 mm		

* Innenkegel
* Internal taper
* Cône interne

** Außenkegel
** External taper
** Cône externe

				
L	L1			
Verteiler freischwebend <i>Distributor, floating</i> <i>Filettage interne deserré</i>	Verteiler freischwebend <i>Distributor, floating</i> <i>Filettage interne deserré</i>	Verteiler <i>Distributor</i> <i>Répartiteur</i>	Verteiler <i>Distributor</i> <i>Répartiteur</i>	Verteiler <i>Distributor</i> <i>Répartiteur</i>
L	L1	MCH982 M10 x 1.00 *	MCH986 M10 x 1.00 *	MCH987 M10 x 1.00 *

Befestigungsteile Attachment parts Pièces de fixation		
Abbildung (Beispiel) <i>Image (example)</i> <i>Illustration (exemple)</i>	Bestell-Nr. <i>Order no.</i> <i>N° comm.</i>	Verpackungseinheit <i>Packaging unit</i> <i>Unité d'emballage</i>
	MV1515	5 St. 5 pcs.
	MV1520	1 St. 1 pc.
	MV1516	2 St. 2 pcs.
	MV1517	5 St. 5 pcs.
	MV1518	5 St. 5 pcs.
	MV1519	5 St. 5 pcs.
	MV1514	5 St. 5 pcs.

Hydraulischer Stopplicht-Schalter <i>Hydraulic stoplight switch</i> <i>Contacteur hydraulique pour feux stop</i>			
Bestell-Nr. <i>Order no.</i> <i>N° comm.</i>		Gewinde <i>Thread</i> <i>Filettage</i>	Verpackungseinheit <i>Packaging unit</i> <i>Unité d'emballage</i>
Einfach <i>Single</i> <i>Simple</i>	MCF935	M10 x 1.0	1 St. 1 pc.
	MCF936	M10 x 1.25	1 St. 1 pc.
Doppelt <i>Double</i> <i>Double</i>	MCF937	M10 x 1.0	1 St. 1 pc.
	MCF938	M10 x 1.25	1 St. 1 pc.
			

Aluminium-Dichtringe <i>Aluminium washers</i> <i>Joints aluminium</i>		
Bestell-Nr. <i>Order no.</i> <i>N° comm.</i>	Details <i>Details</i> <i>Détails</i>	VPE <i>Packaging unit</i> <i>Unité d'emballage</i>
MCH991W20	ø 10 mm	20 St. 20 pcs.
MCH991W50	ø 10 mm	50 St. 50 pcs.
MCH990W10	ø 11,2 mm für for pour Harley-Davidson	10 St. 10 pcs.

REINIGER UND FLÜSSIGKEITEN

PRODUITS DE NETTOYAGE ET LIQUIDES

CLEANER AND FLUIDS

Siedepunkte Boiling points Points chauds					
Bremsflüssigkeit Brake fluid → Liquide de frein	Norm DOT 4	TRW DOT 4	TRW DOT 4 Grand Prix	Norm DOT 5.1	TRW DOT 5.1
Trockensiedepunkt Dry boiling point Point chaud par temps sec	230°	270°	> 300°	260°	269°
Nasssiedepunkt Wet boiling point Point chaud par temps humide	155°	163°	> 195°	180°	187°

Bestellübersicht Ordering overview Aperçu d'une commande		
Spezifikation Specification Type	Bestell-Nr. Order no. N° comm.	Inhalt Contents Contenance
DOT 4	PFB425	250 ml
DOT 4	PFB450	500 ml
DOT 4	PFB401	1 l
DOT 4	PFB405	5 l
DOT 4	PFB420	20 l
DOT 4 Grand Prix	PFB601	1 l
DOT 5.1	PFB525	250 ml
DOT 5.1	PFB550	500 ml
DOT 5.1	PFB501	1 l
DOT 5.1	PFB505	5 l
DOT 5.1	PFB520	20 l
Reiniger Cleaner	PFC105	500 ml

Bremsflüssigkeiten

- » TRW Hochleistungsflüssigkeiten übersteigen internationale Normen und die gesetzlichen Spezifikationen (s. Tabelle)
- » problemlos mischbar mit anderen Bremsflüssigkeiten der gleichen Spezifikation
- » TRW DOT 4 Grand Prix ist für besonders hohe Sicherheitsansprüche und den Rennsport entwickelt worden. Bei der Verwendung von Sinterbelägen ebenfalls empfohlen, da die Temperaturentwicklung höher ist.

Brake fluids

- » TRW high-performance fluids exceed the international standards and the legal specifications (see table).
- » mixable with all brake fluids of the same specification
- » TRW DOT 4 Grand Prix is specially developed to meet the increase in safety requirements and for racing where the use of sintered metal pads increases temperatures.

Liquides de freins

- » le liquide TRW haute performance est supérieur aux normes internationales et aux spécifications légales (voir tableau).
- » compatible avec d'autres liquides de frein disposant des mêmes spécifications.
- » TRW DOT 4 Grand Prix a été développé pour la compétition et répondre à des exigences de sécurité très élevées. Il est recommandé en cas d'utilisation de plaquettes tout métal qui génèrent une température de liquides de freins plus élevée.

Entlüftergerät

- » Entlüftungsgerät für Brems-, Kupplungs- und Lenksysteme mit druckluftbetriebener Saugereinheit
- » zum Anschluss an handelsübliche 1/4-Zoll-Druckluftsysteme

Bleeding equipment

- » brake and clutch system bleeding equipment operated by compressed air
- » for connection with standard 1/4 inch compressed air systems

Appareil pour réaliser la purge du circuit hydraulique

- » appareil pour purger le système de freinage et d'embrayage avec unité d'aspiration à air comprimé
- » pour le raccordement aux systèmes pneumatiques 1/4" courants

MCE301

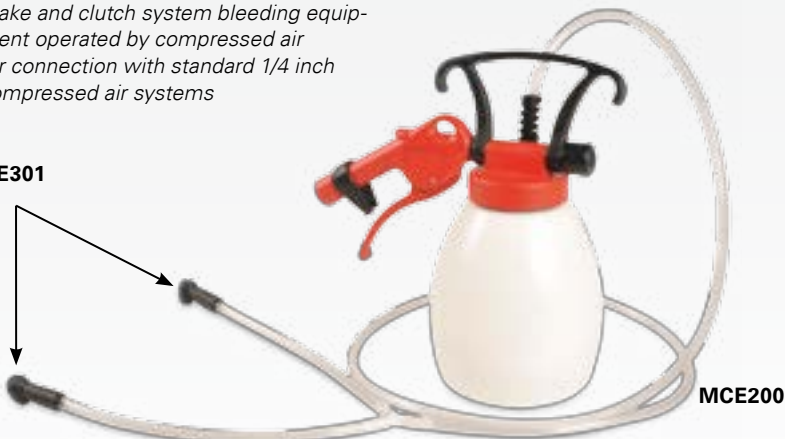

MCE200



PFB601



PFC105



YWB214

Bremsflüssigkeitstester
Brake fluid tester
Appareil de test
pour liquide de frein



Aprilia

■	50 Red Rose Classic		90-94		MCH 607 V1	MCH 911			
■	50 Area 51	MY	98-01		MCH 704 V1	MCH 911			
■	50 Classic	GI	95-99		MCH 607 V1	MCH 911			
■	RS 50 Extrema	HP	96-01		MCH 400 V1	MCH 911			
■	RS 50 Extrema	HP	93-95		MCH 400 V1	MCH 911	MCH 210 H1	MCH 911	
■	SR 50	RL	97-01		MCH 705 V1	MCH 911			
■	RS 80 Extrema		93-		MCH 400 V1	MCH 911	MCH 210 H1	MCH 911	
■	125 Classic	MF	96-99		MCH 804 V1	MCH 911			
■	125 Leonardo	MB00	96-98		MCH 808 V1	MCH 911			
■	AF 1 125 Futura	FM	91-		MCH 830 V1	MCH 911			
■	AF 1 125 Sport Pro		93-		MCH 800 V1	MCH 911	MCH 800 H1	MCH 911	
■	ETX 125	PH	98-00		MCH 807 V1	MCH 911	MCH 807 H1	MCH 911	
■	RS 125	MP	99-04		MCH 811 V1	MCH 911	MCH 811 H1	MCH 911	
■	RS 125	GS	96-98		MCH 830 V1	MCH 911	MCH 811 H1	MCH 911	
■	RS 125 Extrema	GS	93-95		MCH 830 V1	MCH 911		MCH 911	
■	SR 125	PX 125	97-01		MCH 705 V1	MCH 911			
■	150 Leonardo	MB	96-98		MCH 808 V1	MCH 911			
■	250 Leonardo	PD	96-01		MCH 802 V1	MCH 911			
■	RS 250	LD01	95-97		MCH 801 V3	MCH 911	MCH 801 H1	MCH 911	
■	RS 250	LD01	98-01		MCH 805 V3	MCH 911	MCH 801 H1	MCH 911	
■	650 Pegaso	MA	93-94		MCH 809 V1	MCH 911	MCH 802 H1	MCH 911	
■	650 Moto	MH00	95-99		MCH 803 V1	MCH 911			
■	650 Pegaso	MX,ML	95-00		MCH 802 V1	MCH 911	MCH 802 H1	MCH 911	
■	ETV 1000 CapoNord	PS	01-03		MCH 812 V3	MCH 911	MCH 433 H1	MCH 911	
■	RST 1000 Futura	PW	01-		MCH 813 V3	MCH 911	MCH 310 H1	MCH 911	
■	RSV 1000 Mille	RP	01-03			MCH 911	MCH 806 H1	MCH 911	
■	RSV 1000 Mille	ME	98-00		MCH 806 V3	MCH 911	MCH 806 H1	MCH 911	
■	RSV 1000 R	RR	04-			MCH 911			
■	SL 1000 Falco	PA	00-04		MCH 810 V3	MCH 911	MCH 263 H1	MCH 911	

Benelli

■	491 50 Racing	BA 01	98-06		MCH 706 V1	MCH 911			
■	K2 50 AC	BA 01	98-00		MCH 702 V1	MCH 911			
	125 Adiva	D1	00-07		MCH 804 V1	MCH 911			
■	250 Adiva		00-07		MCH 804 V1	MCH 911			

BMW

■	R 450 RT	248	81-84		MCH 534 V3	MCH 911			
■	R 450 T	248	78-80		MCH 503 V3	MCH 911			
■	R 45 450	248	78-8/81		MCH 500 V2				
■	R 45 450	248	9/81-84		MCH 536 V3	MCH 911			
■	R 60 600 /7	R60/7	76-80		MCH 516 V1				
■	R 60 600 T	R60/7	76-80		MCH 510 V1				
■	F 650	169	94-99		MCH 508 V1	MCH 911	MCH 508 H1	MCH 911	
■	F 650 GS	R13	00-02			MCH 911	MCH 501 H1	MCH 911	
■	F 650 GS Dakar	R13	00-02		MCH 501 V1	MCH 911	MCH 501 H1	MCH 911	
■	F 650 ST	169	96-99		MCH 508 V1	MCH 911	MCH 508 H1	MCH 911	
■	R 65 650	248	78-8/81		MCH 500 V2				
■	R 65 650		85-6/88		MCH 537 V1	MCH 911			
■	R 65 650	247	7/88-		MCH 506 V1	MCH 911			
■	R 65 650 LS	248	9/81-85		MCH 536 V3	MCH 911			
■	R 65 650 RT	248	81-84		MCH 534 V3	MCH 911			
■	R 65 650 G/S	247	81-87		MCH 505 V1				
■	R 65 650 RT	248	85-86		MCH 504 V2	MCH 911			
■	R 65 650 RT	247	87-		MCH 515 V2	MCH 911			
■	K 75 750	75	88-8/91		MCH 503 V3	MCH 911			
■	K 75 750 /2	75	9/91-94		MCH 509 V1	MCH 911	MCH 530 H1		
■	K 75 750 C	75	85-88		MCH 503 V3	MCH 911			
■	K 75 750 RT	75	91-94		MCH 509 V1	MCH 911	MCH 530 H1		
■	K 75 750 S	75	86-8/91		MCH 531 V3	MCH 911	MCH 530 H1		
■	K 75 750 S	75	9/91-94		MCH 507 V1	MCH 911	MCH 530 H1		
■	R 75 750 /6	R75/6	73-76		MCH 516 V1				



++/+ inkl. aller Schrauben – incl. bolts
 ++ inkl. Doppelhohlschraube – incl. doublebolt
 * Umbau auf Doppelbremse – double disc

Edelstahl poliert – stainless steel polished
 ohne Verteiler – without distributor
 Doppelzündung – Twin Spark

Flachlenker – Flatbar
 Hochlenker – Highbar
 BASIC Ohne Leitungen – Without hoses
 unter dem Tank – under fuel tank

**BMW**

■ R 75	750 /7	R75/7	76-80		MCH 516 V1				
■ R 75	750 /6	R75/6	73-76	*	MCH 502 V2				
■ R 80	800		76-80		MCH 502 V2				
■ R 80	800	247	81-84		MCH 514 V3	MCH 911			
■ R 80	800	247	85-6/88		MCH 537 V1	MCH 911			
■ R 80	800	247	7/88-		MCH 506 V1	MCH 911			
■ R 80	800 /7	247	77-		MCH 502 V2				
■ R 80	800 T		76-80		MCH 510 V1				
■ R 80	800 T		76-80	*	MCH 522 V2				
■ R 80	800 G/S	247E	81-87		MCH 505 V1				
■ R 80	800 GS	247E	7/87-7/90		MCH 506 V1	MCH 911			
■ R 80	800 GS	247E	8/90-95		MCH 546 V1	MCH 911			
■ R 80	800 GS Basic	247	96-		MCH 546 V1	MCH 911			
■ R 80	800 GS Paris Dakar	247E	7/87-7/90		MCH 505 V1				
■ R 80	800 GS Paris Dakar	247E	8/90-95		MCH 546 V1	MCH 911			
■ R 80	800 R	247	93-95		MCH 549 V1	MCH 911			
■ R 80	800 R Mystik		94-95		MCH 519 V1	MCH 911			
■ R 80	800 RT	247	80-84		MCH 504 V2	MCH 911			
■ R 80	800 RT	247	85-86		MCH 504 V2	MCH 911			
■ R 80	800 RT (DS)		80-84		MCH 520 V3	MCH 911			
■ R 80	800 RT	247	87-		MCH 515 V2	MCH 911			
■ R 80	800 ST	247E	82-84		MCH 505 V1				
■ R	850 C	259C	97-01		MCH 539 V4	MCH 911	MCH 535 H1	MCH 911	
■ R	850 C	259C	97-01	∩	MCH 535 V4	MCH 911	MCH 535 H1	MCH 911	
■ R	850 GS	259	98-00		MCH 512 V3	MCH 911	MCH 512 H1	MCH 911	
■ R	850 GS ABS	R21	98-00		MCH 540 V4	MCH 911	MCH 512 H1	MCH 911	
■ R	850 R	259	94-02	++	MCH 524 V2	MCH 911	MCH 512 H1	MCH 911	
■ R	850 R ABS	259	94-02		MCH 542 V4	MCH 911	MCH 512 H1	MCH 911	
■ R 90	900 /6	R90/6	73-76		MCH 516 V1				
■ R 90	900 /6	R90/6	73-76	*	MCH 502 V2				
■ R 90	900 S	R90/S	73-76		MCH 502 V2				
■ K 1	1000	100	89-93		MCH 533 V3	MCH 911			
■ K 100	1000		83-89		MCH 503 V3	MCH 911	MCH 530 H1		
■ K 100	1000 LT		83-89		MCH 529 V3	MCH 911	MCH 530 H1		
■ K 100	1000 RS		83-91		MCH 531 V3	MCH 911	MCH 530 H1		
■ K 100	1000 RS (16 V) ohne ABS		90-92		MCH 511 V3	MCH 911	MCH 511 H1	MCH 911	
■ K 100	1000 RT		83-89		MCH 529 V3	MCH 911	MCH 530 H1		
■ R 100	1000 RT		76-80		MCH 522 V2		MCH 515 H1		
■ R 100	1000 /7	247	76-80		MCH 502 V2				
■ R 100	1000 CS	247	80-85		MCH 514 V3	MCH 911			
■ R 100	1000 GS		7/87-7/90		MCH 506 V1	MCH 911			
■ R 100	1000 GS		8/90-95		MCH 546 V1	MCH 911			
■ R 100	1000 GS Paris Dakar	247E	7/87-7/90		MCH 505 V1				
■ R 100	1000 GS Paris Dakar	247E	8/90-95		MCH 546 V1	MCH 911			
■ R 100	1000 R	247	92-95		MCH 549 V1	MCH 911			
■ R 100	1000 R Mystik	247	94-95		MCH 519 V1	MCH 911			
■ R 100	1000 RS		76-80		MCH 522 V2		MCH 515 H1		
■ R 100	1000 RS	247	81-84		MCH 525 V3	MCH 911	MCH 515 H1		
■ R 100	1000 RS	247	85-86		MCH 530 V2	MCH 911			
■ R 100	1000 RS	247	87-92		MCH 515 V2	MCH 911			
■ R 100	1000 RT	247	81-84		MCH 520 V3	MCH 911	MCH 515 H1		
■ R 100	1000 RT	247	9/86-95		MCH 515 V2	MCH 911			
■ R 100	1000 S	247	76-80		MCH 502 V2		MCH 515 H1		
■ R 100	1000 T		76-80		MCH 502 V2				
■ K	1100 RS ABS	100	93-99		MCH 548 V3	MCH 911	MCH 560 H1	MCH 911	
■ K	1100 LT	100	92-99		MCH 548 V3	MCH 911	MCH 511 H1	MCH 911	
■ K	1100 LT ABS	100	93-99		MCH 560 V4	MCH 911	MCH 560 H1	MCH 911	
■ K	1100 RS	100	93-99		MCH 511 V3	MCH 911	MCH 511 H1	MCH 911	
■ R	1100 GS	259	94-99		MCH 512 V3	MCH 911	MCH 512 H1	MCH 911	
■ R	1100 GS ABS	259	94-99		MCH 540 V4	MCH 911	MCH 512 H1	MCH 911	
■ R	1100 R	259	94-00	++	MCH 524 V2	MCH 911	MCH 512 H1	MCH 911	
■ R	1100 R ABS	259	94-00		MCH 542 V4	MCH 911	MCH 512 H1	MCH 911	
■ R	1100 RS	259	93-01		MCH 523 V3	MCH 911	MCH 523 H1	MCH 911	
■ R	1100 RS ABS	259	93-01		MCH 541 V4	MCH 911	MCH 523 H1	MCH 911	
■ R	1100 RT ABS	259	96-01		MCH 573 V4	MCH 911	MCH 573 H1	MCH 911	
■ R	1100 S	R2S	98-00		MCH 543 V3	MCH 911	MCH 543 H1	MCH 911	



BMW

■ R	1100 S	R2S,R11S	01-03		MCH 571 V3	MCH 911	MCH 543 H1	MCH 911
■ R	1100 S ABS	R2S,R11S	98-00		MCH 544 V4	MCH 911	MCH 543 H1	MCH 911
R	1100 S		04-	Boxer Cup ☎		MCH 911	☎	MCH 911
■ R	1150 GS	R21	99-02		MCH 563 V3	MCH 911	MCH 563 H1	MCH 911
■ R	1150 GS ABS	R21	99-01		MCH 564 V4	MCH 911	MCH 563 H1	MCH 911
■ R	1150 R ABS	R21	01-		MCH 572 V4	MCH 911	MCH 572 H1	MCH 911
R	1150 GS	R21	03-04	2⚡	☎	MCH 911	☎	MCH 911
■ K	1200 RS ABS	589	97-01		MCH 547 V4	MCH 911	MCH 547 H2	MCH 911
■ R	1200 C	259C	97-02		MCH 539 V4	MCH 911	MCH 535 H1	MCH 911
■ R	1200 C	259C	97-02	⤿	MCH 535 V4	MCH 911	MCH 535 H1	MCH 911

Cagiva

■	125 Mito	8P	91-92		MCH 830 V1	MCH 911	MCH 830 H1	
■	125 Mito 2	8P	93-94		MCH 830 V1	MCH 911	MCH 830 H1	
■	125 Mito EVO	8P	95-07		MCH 830 V1	MCH 911	MCH 830 H1	
■	125 Raptor	N3	05-		MCH 507 V1	MCH 911	MCH 830 H1	
■	125 Super City	2F	93-98		MCH 832 V1	MCH 911		
W 8	125		92-94		☎	MCH 911	MCH 145 H1	MCH 911
	350 Allazzurra		85-86				MCH 139 H1	MCH 911
■ W12	350		94-95		MCH 837 V1	MCH 911	MCH 837 H1	MCH 911
■	600 River	3G	96-98		MCH 836 V1	MCH 911	MCH 836 H1	MCH 911
■	600 Canyon	5G	96-97		MCH 424 V1	MCH 911	MCH 424 H1	MCH 911
■ W16	600	2G	94-96		MCH 837 V1	MCH 911	MCH 837 H1	MCH 911
■	650 Allazzurra		85-86				MCH 139 H1	MCH 911
■	650 Elefant		85-87		MCH 835 V1	MCH 911		
■	750 Elefant	B	87-91		MCH 835 V1	MCH 911		
■	750 Elefant	B	94-97		MCH 834 V1	MCH 911	MCH 834 H1	MCH 911
■	900 Elefant I.E	B	90-92		MCH 834 V1	MCH 911		
■	900 Elefant AC		93-96		MCH 833 V3	MCH 911	MCH 834 H1	MCH 911
■	900 Gran Canyon	M3	99-		☎	MCH 911	☎	MCH 911

Daelim

■	125 Roadwin	VJ125	03-07		MCH 382 V1			
■ VC	125 Advance	VS125	95-97		MCH 415 V1			
■ VL	125 Daystar	VL125F	00-07		MCH 168 V1			

Derbi

■	50 Senda (H)		94-98		MCH 170 V1			
---	--------------	--	-------	--	------------	--	--	--

Ducati

■	400 SS	S	93-95		MCH 400 V1	MCH 911	MCH 606 H1	MCH 911
■	500 Pantah		80-84		MCH 601 V3	MCH 911	MCH 340 H1	MCH 911
■	600 Pantah		80-84		MCH 601 V3	MCH 911	MCH 340 H1	MCH 911
■	600 Monster	M	94-99		MCH 608 V1	MCH 911	MCH 602 H1	MCH 911
■	600 SS	S	94-98		MCH 400 V1	MCH 911	MCH 606 H1	MCH 911
■	748 Biposto	748	95-97		MCH 610 V3	MCH 911	MCH 610 H1	MCH 911
■	750 F1		87-88		MCH 603 V3	MCH 911		
■	750 Monster	M	96-97		MCH 608 V1	MCH 911	MCH 602 H1	MCH 911
■	750 Monster	M	98-00		MCH 600 V3	MCH 911	MCH 602 H1	MCH 911
■	750 SS	S	91-94		MCH 400 V1	MCH 911	MCH 606 H1	MCH 911
■	750 SS	S	92-97	++ *	MCH 605 V2	MCH 911	MCH 606 H1	MCH 911
■	750 Sport		88-90		☎	MCH 911	MCH 124 H1	MCH 911
■	851 Strada		87-92	++	MCH 606 V2	MCH 911	MCH 606 H1	MCH 911
■	888 S.P. 5	S	93-94	++	MCH 606 V2	MCH 911	MCH 601 H1	MCH 911
■	888 Strada	S	91-94	++	MCH 606 V2	MCH 911	MCH 606 H1	MCH 911
■	900 S2 Desmo	S	83-		MCH 603 V3	MCH 911	MCH 142 H1	MCH 911
■	900 SS	S	90		MCH 604 V3	MCH 911	MCH 604 H1	MCH 911
■	900 SS/Repl.	S	-89		MCH 603 V3	MCH 911	MCH 142 H1	MCH 911
■	900 Monster	M	93-97		MCH 600 V3	MCH 911	MCH 602 H1	MCH 911
■	900 SS	S	91-97	++	MCH 605 V2	MCH 911	MCH 606 H1	MCH 911
■	900 Superlight		93-97	++	MCH 605 V2	MCH 911	MCH 602 H1	MCH 911
■	900 Monster i.E.		00-02		☎	MCH 911	MCH 602 H1	MCH 911



++/+ inkl. aller Schrauben – incl. bolts
 ++ inkl. Doppelhohlschraube – incl. doublebolt
 * Umbau auf Doppelbremse – double disc

☐ Edelstahl poliert – stainless steel polished
 ✳ ohne Verteiler – without distributor
 2⚡ Doppelzündung – Twin Spark

⤿ Flachlenker – Flatbar
 ⤿ Hochlenker – Highbar
 BASIC Ohne Leitungen unter dem Tank – Without hoses under fuel tank



Ducati

	900 SS		98-			MCH 911			
■	907 I.E.		91-93		MCH 611 V3	MCH 911		MCH 611 H1	MCH 911
■	916 Biposto	916	94-97		MCH 610 V3	MCH 911		MCH 610 H1	MCH 911
■	944 ST 2	S1	97-00		MCH 612 V3	MCH 911		MCH 470 H1	MCH 911
■	944 ST4	S2	99-04		MCH 612 V3	MCH 911		MCH 470 H1	MCH 911
■	996 Biposto		99-00			MCH 911		MCH 610 H1	MCH 911
■	1000 Mike Hailwood	MH	84-86		MCH 603 V3	MCH 911		MCH 142 H1	MCH 911
■	1098 S/R	H7	07-					MCH 233 H1	MCH 911
■	1198 S/R	H7	09-					MCH 233 H1	MCH 911

Gilera

■	FX	125 Runner	MO 7	98		MCH 538 V1	MCH 911		
■	FX	125 Runner SP	MO 7	99-		MCH 838 V1	MCH 911		
■	FXR	180 Runner	MO 8	98		MCH 538 V1	MCH 911		
■	FXR	180 Runner SP	MO 8	99-		MCH 838 V1	MCH 911		
■		500 Saturno		91-		MCH 830 V1	MCH 911		MCH 911

Harley-Davidson

■	FXEF	883		84-85		MCH 732 V1			
■	XL	883 Sportster Custom	53C	01-03		MCH 730 V1	MCH 931	MCH 941	
	XLH	883 Sportster Iron		09-					
■	XLH	883 Sportster		85-03		MCH 730 V1			
■	XLH	1100 Sportster		84-87		MCH 732 V1			
■	VRSCA	1130 V-Rod	VR1	02-06		MCH 738 V3			
■	XL	1200 Sportster Custom		04-10		MCH 740 V1	MCH901		MCH 740 H1
	XL	1200 X, Forty-Eight		10-					
■	XLH	1200 Sportster Custom		96-03		MCH 730 V1	MCH 931	MCH 941	
■	XLH	1200 Sportster		87-95	☐	MCH 737 V1C			
■	FLST	1340		86-90		MCH 731 V1			
■	FLST	1340 Fat Boy		90-00		MCH 731 V1			
■	FLSTC	1340 H. Softail Classic		86-89		MCH 731 V1			
■	FLSTC	1340 H. Softail Springer		88-91					MCH 736 H2C
■	FLSTC	1340 H. Softail Classic		90-99	☐	MCH 733 V1C			
■	FLSTC	1340 H. Softail Springer		94-99		MCH 732 V1			
■	FLSTN	1340 H. Softail Special		94-96		MCH 731 V1			
■	FXD	1340 Dyna Super Glide	FD1	98-	☐	MCH 734 V1C			
■	FXDWG	1340 Dyna W. Glide		93-	☐	MCH 736 V1C			
■	FXE	1340		84-85		MCH 732 V1			
■	FXLR	1340 Low Rider Custom		87-94	☐	MCH 734 V1C			
■	FXRS	1340 Low Rider		87-90		MCH 732 V1			
■	FXRS	1340 Super Glide		84-91		MCH 732 V1			
■	FXST	1340 Softail Custom		84-	☐	MCH 736 V1C			MCH 736 H2C
■	FXSTB	1340 Bad Boy		95-97	☐	MCH 733 V1C			
■	FXSTB	1340 Night Train		98-00	☐	MCH 731 V1C	MCH 931	MCH 941	
■	FXSTS	1340 Springer Softail		92-99	☐	MCH 735 V1C	MCH 931	MCH 941	
■	FXWG	1340 Wide Glide		84-86	☐	MCH 735 V1C			
	FXDWG	1450 Dyna Wide Glide		95-06	☐	MCH 737 V1C			
■	FLST	1450 Fat Boy		01-05	☐	MCH 731 V1C	MCH 931	MCH 941	
■	FLSTC	1450 H. Softail Classic		00-04	☐	MCH 739 V1C	MCH 931	MCH 941	
■	FLSTC	1450 H. Softail Springer		00-05		MCH 732 V1	MCH 931	MCH 941	
■	FXST	1450 Softail Standard		00-06	☐	MCH 735 V1C	MCH 931	MCH 941	
■	FXSTB	1450 Night Train		01-06	☐	MCH 731 V1C	MCH 931	MCH 941	
■	FXSTD	1450 Softail Deuce	FS2	00-05	☐	MCH 731 V1C	MCH 931	MCH 941	
	FXSTS	1450 Softail Springer		00-04	☐	MCH 735 V1C	MCH 931	MCH 941	
■	FXDB	1584 Dyna Street Bob		07-10	☐	MCH 731 V1C	MCH 931		
	FXDF	1584 Fat Bob		08-					

Honda

■	NSR	50	AC08	89-96		MCH 261 V1	MCH 901		
■	SJ	50 Bali	AF32	93-01		MCH 703 V1	MCH 901		
■	SZX	50 X8R-S,X8R-X	AF49	98-01		MCH 717 V1	MCH 901		
	NSR	75	DC03	92-99		MCH 402 V1	MCH 901		MCH 383 H1
■	MBX	80 SW2	HC04	82-90		MCH 261 V1	MCH 901		
■	MBX	80 SWD	HC04	82-90		MCH 261 V1	MCH 901		
■	MBX	80 SWZ	HC04	82-90		MCH 261 V1	MCH 901		
■	MTX	80 R2	HD09	87-90		MCH 100 V1	MCH 901		
■	CA	125 Rebel	JC24	95-96		MCH 168 V1	MCH 901		



Honda

■ CA	125 Rebel	JC26	97-00			MCH 185 V1				
■ CBF	125	JC40A	09-11			MCH 200 V1	MCH 901			
■ CBR	125	JC34	04-06			MCH 824 V1	MCH 901	MCH 824 H1	MCH 901	
■ CBR	125	JC39	07-10			MCH 824 V1	MCH 901	MCH 824 H1	MCH 901	
■ CLR	125	JD18B	98-99			MCH 358 V1				
■ CR	125 R	JE01	88-91			MCH 165 V1	MCH 901			
■ CR	125 R	JE01	92-94			MCH 181 V1				
■ CR	125 R		95-03			MCH 191 V1				
■ CRM	125		90-97			MCH 182 V1				
■ MTX	125 RW		85-89			MCH 111 V1	MCH 901			
■ MSX	125		13-			MCH 897 V1		MCH 897 H1		
■ NES	125 @	JF07	01-06			MCH 707 V1	MCH 901			
■ NSR	125 R	JC22	94-98			MCH 228 V1		MCH 175 H1		
■ NSR	125 R	JC22	99-03			MCH 228 V1		MCH 214 H1		
■ NX	125 Transcity	JD09	89-97			MCH 538 V1				
■ SH	125	JF09	01-04			MCH 707 V1	MCH 901			
■ VT	125 C Shadow	JC29	99-00			MCH 213 V1	MCH 901			
■ VT	125 C Shadow	JC31	01-03			MCH 196 V1	MCH 901			
■ XLR	125 R	JD	98-99			MCH 178 V1				
■ XLV	125 Varadero	JC32	01-06			MCH 463 V1	MCH 901	MCH 463 H1	MCH 901	
■ XLV	125 Varadero	JC32	07-			MCH 804 V1	MCH 901	MCH 193 H1	MCH 901	
XR	125 R		07-							
■ CB	250 G	CB250	74-76			MCH 105 V2				
■ CB	250 N, ND	CB250N	79-82			MCH 513 V1				
■ CB	250 Two-fifty	MC26	96-97			MCH 804 V1				
■ CJ	250 T	CJ250T	76-78			MCH 136 V2				
■ CMX	250 Rebel	MC13B	96-99			MCH 168 V1	MCH 901			
■ CR	250 R	ME03	87-91			MCH 165 V1	MCH 901			
■ CR	250 R	ME03	92-94			MCH 181 V1				
■ CR	250 R	ME03	95-03			MCH 191 V1				
CR	250 R	ME03	04-07							
CRF	250		95-04			MCH 191 V1				
CRF	250 R		05-14			MCH 181 V1				
■ NX	250	MD21	88-90			MCH 417 V1	MCH 901			
■ NX	250	MD25	91-95			MCH 417 V1	MCH 901			
VTR	250	MC33	96-							
■ XL	350 R	ND03	85-88			MCH 111 V1	MCH 901			
■ CJ	360 T	CJ360T	76-78			MCH 136 V2	MCH 901			
■ CB	400 Super Four		93-	++		MCH 469 V2	MCH 901	MCH 139 H1	MCH 901	
■ CB	400 F	CB400F	75-77			MCH 129 V2	MCH 901			
■ CB	400 N	CB400N	78-82			MCH 101 V3	MCH 901			
■ CB	400 Twin	CB400T	79-81			MCH 513 V1	MCH 901			
■ CB-1	400 F	NC27	89-			MCH 164 V1	MCH 901	MCH 168 H1	MCH 901	
■ CBR	400 RR	NC29	91-96	++		MCH 161 V2	MCH 901	MCH 423 H1	MCH 901	
■ CM	400 T	NC01	80-84			MCH 102 V1	MCH 901			
■ NSR	400 R	NC19	85-			MCH 449 V3	MCH 951 MCH 901	MCH 340 H1	MCH 901	
■ RVF	400 RR	NC35	94-97	++		MCH 161 V2	MCH 901		MCH 901	
■ VFR	400 R	NC30	91-	++		MCH 167 V2	MCH 901	MCH 167 H1	MCH 901	
■ CB	450 N	PC14	85-			MCH 157 V3	MCH 951 MCH 901			
■ CB	450 S	PC17	87-89			MCH 104 V3	MCH 951 MCH 901			
■ CRF	450	PE05	02-08			MCH 191 V1	MCH 901			
CRF	450		09-14			MCH 181 V1	MCH 901			
■ CB	500	PC26	94-96			MCH 133 V1	MCH 901			
■ CB	500	PC32	97-03			MCH 133 V1	MCH 911	MCH 133 H1	MCH 911	
■ CB	500 Four	CB500	77-			MCH 105 V2	MCH 901			
■ CB	500 S	PC32	98-03			MCH 133 V1	MCH 911	MCH 133 H1	MCH 911	
■ CR	500 R	PE02	92-94			MCH 181 V1				
■ CR	500	PE02	95-01			MCH 191 V1		MCH 191 H1		
■ CR	500 R	PE02	89-91			MCH 165 V1	MCH 901			
■ CX	500	CX500	79-82			MCH 110 V3	MCH 901			
■ CX	500 C	PC01	80-84			MCH 442 V3	MCH 901			



++/+ inkl. aller Schrauben – incl. bolts
 ++ inkl. Doppelhohlschraube – incl. doublebolt
 * Umbau auf Doppelbremse – double disc

☐ Edelstahl poliert – stainless steel polished
 ✳ ohne Verteiler – without distributor
 2⚡ Doppelzündung – Twin Spark

~ Flachlenker – Flatbar
 ~ Hochlenker – Highbar
 BASIC Ohne Leitungen – Without hoses
 unter dem Tank – under fuel tank



Honda

■	CX	500 E	PC06	82-86				MCH 163 V3				MCH 163 H1	MCH 901
■	CX	500 TC	PC03	82-85				MCH 158 V3	MCH 951	MCH 901		MCH 163 H1	MCH 901
■	FT	500 C	PC07	82-84				MCH 185 V1		MCH 901			
■	GB	500 Clubmann	PC16	92-				MCH 200 V1		MCH 901			
■	GL	500 D	PC02	82-85				MCH 160 V3	MCH 951	MCH 901			
■	VF	500 F2	PC12	84-				MCH 421 V3	MCH 951	MCH 901		MCH 219 H1	MCH 901
■	VT	500 C	PC08	83-				MCH 358 V1		MCH 901			
■	VT	500 E	PC11	83-85				MCH 415 V1		MCH 901			
■	XBR	500 S	PC15	85-90				MCH 107 V1		MCH 901			
■	CB	550 F		79-80				MCH 183 V2		MCH 901			
■	CB	550 K3		77-79				MCH 183 V2		MCH 901			
■	CBX	550 F	PC04	82-85				MCH 116 V3	MCH 951	MCH 901		MCH 116 H1	MCH 901
■	CB	600 Hornet	PC34	98-01	++			MCH 469 V2		MCH 901		MCH 469 H1	MCH 901
■	CB	600 Hornet	PC36	02-06	++			MCH 197 V2		MCH 901		MCH 197 H1	MCH 901
■	CB	600 Hornet	PC 41	07-10	++			MCH 469 V2		MCH 901		MCH 133 H1	MCH 901
■	CB	600 Hornet ABS	PC 41	07-11				MCH 856 V4				MCH 856 H2	MCH 901
■	CBF	600	PC38	04-07	++			MCH 818 V2		MCH 901		MCH 818 H1	MCH 901
	CBF	600	PC43	08-									
■	CBF	600 ABS	PC38	04-07	++			MCH 819 V3		MCH 901		MCH 819 H2	MCH 901
	CBF	600 ABS	PC43	08-									
■	CBR	600 F	PC19	87-88				MCH 155 V3	MCH 951	MCH 901		MCH 113 H1	MCH 901
■	CBR	600 F	PC23	89-90				MCH 155 V3	MCH 951	MCH 901		MCH 155 H1	MCH 901
■	CBR	600 F	PC25	91-94	++			MCH 162 V2		MCH 901		MCH 139 H1	MCH 901
■	CBR	600 F	PC31	95-98	++			MCH 469 V2		MCH 901		MCH 139 H1	MCH 901
■	CBR	600 F	PC35	99-06	++			MCH 186 V2		MCH 901		MCH 186 H1	MCH 901
■	CBR	600 F ABS		11-				MCH 889 V4				MCH 889 H2	
■	CBR	600 RR	PC37	03-04	++			MCH 198 V2		MCH 901		MCH 198 H1	MCH 901
■	CBR	600 RR	PC37	05-06	++			MCH 817 V2		MCH 901		MCH 198 H1	MCH 901
■	CBR	600 RR	PC40	07-08	++			MCH 829 V2		MCH 901		MCH 829 H1	MCH 901
■	CBR	600 RR ABS	PC40	09-12	++			MCH 863 V3		MCH 901		MCH 863 H2	MCH 901
	CBR	600 RR ABS		13-14									
■	VT	600 C	PC21	88-97				MCH 156 V1		MCH 901			
■	VT	600 C	PC21	98-00				MCH 185 V1		MCH 901			
■	XL	600 LM	PD04	85-86				MCH 111 V1		MCH 901			
■	XL	600 RM	PD04	85-86				MCH 111 V1		MCH 901			
■	XL	600 V Transalp	PD06	87-90				MCH 112 V1		MCH 901		MCH 165 H1	MCH 901
■	XL	600 V Transalp	PD06	91-96				MCH 168 V1		MCH 901		MCH 166 H1	MCH 901
■	XL	600 V Transalp	PD10	97-99	++			MCH 139 V2		MCH 901		MCH 166 H1	MCH 901
■	XL	600 V Transalp	PD10	99	++			MCH 139 V2		MCH 901		MCH 161 H1	MCH 901
■	XR	600 R	PE04	85-87				MCH 114 V1		MCH 901			
■	XR	600 R	PE04	88-90				MCH 166 V1		MCH 901			
■	XR	600 R	PE04	91-00				MCH 166 V1		MCH 901		MCH 272 H1	MCH 901
■	CB	650	RC03	79-81				MCH 142 V3	MCH 951	MCH 901			
■	CB	650 C	RC05	80-84				MCH 118 V3	MCH 951	MCH 901			
■	CBX	650 E	RC13	83-				MCH 117 V3	MCH 951	MCH 901			
■	CX	650 C	RC11	83-85				MCH 442 V3	MCH 951	MCH 901			
■	CX	650 E	RC12	83-85				MCH 163 V3	MCH 951	MCH 901		MCH 163 H1	MCH 901
■	FMX	650	RD12	05-07				MCH 820 V1		MCH 901		MCH 820 H1	MCH 901
■	FX	650 Vigor	RD09	99-00				MCH 185 V1		MCH 911		MCH 185 H1	MCH 911
■	NT	650 Hawk	RC31	92-				MCH 107 V1		MCH 901		MCH 481 H1	MCH 901
■	NT	650 V Deauville	RC47	98-01	++			MCH 184 V2		MCH 911		MCH 212 H1	MCH 901
■	NT	650 V Deauville	RC47	02-04								MCH 212 H1	MCH 901
■	NTV	650 Revere	RC33	88-97				MCH 115 V1		MCH 901		MCH 210 H1	MCH 901
■	NX	650 Dominator	RD02	88-96				MCH 417 V1		MCH 901		MCH 438 H1	MCH 901
■	NX	650 Dominator	RD08	97-99				MCH 834 V1		MCH 911		MCH 101 H1	
■	SLR	650	RD09	97-98				MCH 168 V1		MCH 911		MCH 133 H1	MCH 911
■	XL	650 V Transalp	RD10	00-01	++			MCH 154 V2		MCH 921		MCH 161 H1	MCH 921
■	XL	650 V Transalp	RD11	02-07	++			MCH 154 V2		MCH 921		MCH 161 H1	MCH 921
	XR	650 L	PE02	91-								MCH 272 H1	MCH 901
■	XR	650 R	RE01	00-07								MCH 133 H1	MCH 901
■	XRV	650 Afrika Twin	RD03	88-90				MCH 174 V1		MCH 901		MCH 161 H1	MCH 901
■	VF	700 C, Magna		84-				MCH 151 V3					
■	CB	750 Four	CB750	76-80				MCH 126 V3	MCH 951	MCH 901			
■	CB	750 C	RC06	80-				MCH 151 V3		MCH 901			
■	CB	750 F	RC04	80-83				MCH 124 V3	MCH 951	MCH 901		MCH 124 H1	MCH 901
■	CB	750 F1	CB750G	76-78				MCH 105 V2		MCH 901			



Honda

■ CB	750 F2	CB750G	78-81			MCH 421 V3		MCH 901		MCH 340 H1	MCH 901
■ CB	750 K	RC 01	78-80			MCH 138 V3	MCH 951	MCH 901			
■ CB	750 K2-K7	CB750K	72-77			MCH 129 V2		MCH 901			
■ CB	750 Seven Fifty	RC42	92-98			MCH 169 V3	MCH 951	MCH 901		MCH 153 H1	MCH 901
■ CB	750 Seven Fifty	RC42	99-03			MCH 169 V3	MCH 951	MCH 901		MCH 800 H1	MCH 901
■ CBX	750 F	RC17	84-87			MCH 121 V3	MCH 951	MCH 901		MCH 120 H1	MCH 901
■ RVF	750 R	RC45	94-97	++		MCH 173 V2		MCH 901		MCH 173 H1	MCH 901
■ VF	750 C	RC09	83-88			MCH 123 V3	MCH 951	MCH 901			
■ VF	750 C	RC43	93-98			MCH 168 V1		MCH 901			
■ VF	750 F	RC15	83-86			MCH 121 V3	MCH 951	MCH 901		MCH 120 H1	MCH 901
	VF	750 S	RC07	82-87		☎		MCH 901			
■ VFR	750 F	RC24	86-87			MCH 132 V3	MCH 951	MCH 901		MCH 121 H1	MCH 901
■ VFR	750 F	RC24	88-89	++		MCH 131 V2		MCH 901		MCH 340 H1	MCH 901
■ VFR	750 F	RC36	90-97	++		MCH 153 V2		MCH 901		MCH 153 H1	MCH 901
■ VFR	750 R	RC30	88-	++		MCH 130 V2		MCH 901		MCH 130 H1	MCH 901
■ VT	750 Black Widow	RC48	00-03			MCH 156 V1		MCH 901			
■ VT	750 C	RC29	87-			MCH 556 V1		MCH 901			
■ VT	750 C Shadow	RC44	97-01			MCH 152 V1		MCH 901			
	VT	750 C Shadow	RC50	04-07		☎					
	VT	750 C Shadow	RC50	08-		☎					
	VT	750 C Shadow Spirit, Black Spirit	RC53	07-		☎					
■ XLV	750 R	RD01	85-87			MCH 174 V1		MCH 901			
■ XRV	750 Africa Twin	RD04	89-92	++		MCH 154 V2		MCH 901		MCH 161 H1	MCH 901
■ XRV	750 Africa Twin	RD07	93-98	++		MCH 154 V2		MCH 901		MCH 161 H1	MCH 901
■ XRV	750 Africa Twin	RD07	99-03	++		MCH 154 V2		MCH 901		MCH 153 H1	MCH 901
	PC	800	RC34	89-98		☎					
■ VFR	800	RC46	98-01			MCH 816 V8		MCH 901		MCH 816 H2	MCH 901
■ CB	900 F	SC01	79-81			MCH 138 V3	MCH 951	MCH 901		MCH 340 H1	MCH 901
■ CB	900 F,F2	SC09	82-84			MCH 137 V3	MCH 951	MCH 901		MCH 124 H1	MCH 901
■ CB	900 F Hornet	SC48	02-05	++		MCH 193 V2		MCH 901		MCH 193 H1	MCH 901
■ CBR	900 RR	SC28	92-95	++		MCH 171 V2		MCH 901		MCH 233 H1	MCH 901
■ CBR	900 RR	SC33	96-97	++		MCH 176 V2		MCH 901		MCH 142 H1	MCH 901
■ CBR	900 RR	SC33D	98-99	++		MCH 176 V2		MCH 901		MCH 142 H1	MCH 901
■ CBR	900 RR	SC44	00-01	++		MCH 189 V2		MCH 901		MCH 272 H1	MCH 901
■ CBR	954 RR Fireblade	SC50	02-03	++		MCH 195 V2		MCH 901		MCH 195 H1	MCH 901
■ CB	1000 R	SC60	08-10	++		MCH 853 V2		MCH 901		MCH 853 H1	MCH 901
	CB	1000 R	11-14			☎					
■ CB	1000 RA ABS	SC60	08-10	++		MCH 866 V4		MCH 901		MCH 866 H2	MCH 901
	CB	1000 RA ABS	11-14			☎					
■ CB	1000 Super Four	SC30	92-96			MCH 172 V3	MCH 951	MCH 901		MCH 212 H1	MCH 901
■ CBF	1000 ABS	SC58	06-10	++		MCH 826 V4		MCH 901		MCH 826 H2	MCH 901
■ CBR	1000 F	SC21	87-89	++		MCH 131 V2		MCH 901		MCH 139 H1	MCH 901
■ CBR	1000 F	SC24	90-92	++		MCH 153 V2		MCH 901		MCH 139 H1	MCH 901
■ CBR	1000 F	SC24	93-	Dual CBS		☎				☎	
■ CBR	1000 RR Fireblade	SC57	04-05	++		MCH 108 V2		MCH 901		MCH 108 H1	MCH 901
■ CBR	1000 RR Fireblade	SC57	06-07	++		MCH 108 V2		MCH 901		MCH 388 H1	MCH 901
■ CBR	1000 RR	SC59	08-13	++		MCH 840 V2		MCH 901		MCH 840 H1	MCH 901
■ CBR	1000 RR ABS	SC59	09-13			MCH 877 V3		MCH 901		MCH 877 H2	MCH 901
■ CBX	1000	SC06	81-82			MCH 143 V3	MCH 951	MCH 901		MCH 143 H1	MCH 901
■ GL	1000 K1-K3	GL1, GL2	75-81		~	MCH 217 V3		MCH 901		MCH 148 H1	
■ GL	1000 K1-K3	GL1, GL2	75-81		~	MCH 140 V3		MCH 901		MCH 148 H1	
■ VF	1000 F,F2	SC15	84-85			MCH 141 V3	MCH 951	MCH 901		MCH 121 H1	MCH 901
■ VF	1000 R	SC16	84-86			☎	MCH 951	MCH 901		MCH 142 H1	MCH 901
■ VTR	1000 Firestorm	SC36	97-06	++		MCH 175 V2		MCH 901		MCH 175 H1	MCH 901
■ VTR	1000 SP-1	SC45	00-01	++		MCH 188 V2		MCH 901		MCH 113 H1	MCH 901
■ VTR	1000 SP2	SC45	02-05	++		MCH 194 V2		MCH 901		MCH 194 H1	MCH 901
■ XL	1000 Varadero	SD01, SD02	99-03			MCH 199 V6		MCH 901		MCH 199 H2	MCH 901
	XL	1000 Varadero ABS	SD02	04-07		☎				☎	
■ CB	1100 F	SC11	83-85			MCH 146 V3	MCH 951	MCH 901		MCH 340 H1	MCH 901
■ CB	1100 R	SC08	82-83			MCH 147 V3	MCH 951	MCH 901		MCH 359 H1	MCH 901
■ CB	1100 X-Eleven	SC42	00-03			MCH 190 V10					



++/+ inkl. aller Schrauben – incl. bolts
 ++ inkl. Doppelhohlschraube – incl. doublebolt
 * Umbau auf Doppelbremse – double disc

☎ Edelstahl poliert – stainless steel polished
 ✳ ohne Verteiler – without distributor
 2⚡ Doppelzündung – Twin Spark

~ Flachlenker – Flatbar
 ~ Hochlenker – Highbar
 BASIC Ohne Leitungen unter dem Tank – Without hoses under fuel tank



Honda

■ CBR	1100 XX	SC35	97-06		MCH 192 V10		MCH 901			
■ GL	1100	SC02	79-85		MCH 148 V3	MCH 951	MCH 901		MCH 210 H1	MCH 901
■ ST	1100 Pan European	SC26	90-98	++	MCH 159 V2		MCH 901		MCH 166 H1	MCH 901
■ ST	1100 Pan European	SC26	99-01		MCH 103 V3					
■ VF	1100 C	SC12	83-86		MCH 145 V3	MCH 951	MCH 901		MCH 145 H1	MCH 901
VF	1100 S		84-85				MCH 901		MCH 837 H1	MCH 901
■ VT	1100 C	SC23	85-89		MCH 168 V1		MCH 901			
■ VT	1100 C	SC23	94		MCH 168 V1		MCH 901			
■ VT	1100 C2	SC32	95-99		MCH 106 V1		MCH 901		MCH 106 H1	MCH 901
■ VT	1100 C3	SC39	98-03		MCH 187 V1		MCH 901		MCH 106 H1	
■ GL	1200 D	SC14	84-	Integralbremse	MCH 180 V4					
■ CB	1300 X-4	SC38	97-	++	MCH 179 V2		MCH 901		MCH 233 H1	MCH 901
■ CB	1300 R	SC54	02-05	++	MCH 815 V2		MCH 901		MCH 815 H1	MCH 901
CB	1300 RA ABS	SC54	04-		☎					
■ CB	1300 SA ABS	SC54	05-09	++	MCH 846 V3		MCH 901		MCH 846 H2	MCH 901
■ VT	1300 CX	SC61	10-		MCH 878 V1		MCH 901			
■ VTX	1300 S	SC52	03-07		MCH 814 V1		MCH 901			
■ GL	1500	SC22	91-97		MCH 177 V4					
■ GL	1520 F6C Valkyrie	SC34B	97-02	++	MCH 150 V2		MCH 901		MCH 150 H1	MCH 901

Husqvarna

■ CR	125		96-04		MCH 114 V1		MCH 911			
■ SM	450 R		04-		MCH 191 V1					
SM	570 R		04-		MCH 191 V1					
■ TE	610 I.E.		08-		☎				MCH 114 H1	MCH 911

Hyosung

■	125 Cruise I,II	GA125	95-98		MCH 358 V1					
■	125 Cruise II Classic	GA125	99-00		MCH 168 V1					
■ GF	125	GF125	98-		MCH 462 V1					
■ GS	125	GS125	97-99		MCH 804 V1					
■ GT	125 Naked	GT	03-09		☎					
■ GT	125 R Supersport		07-		☎					
■ GV	125 Aquila	GV125	00-07		MCH 239 V1					
■ XRX	125 Offroad	RX125	99-06		MCH 718 V1					
■ XRX	125 SM		07-		MCH 718 V1				MCH 121 H1	
■ GV	250 Aquila	GV250	00-		MCH 152 V1					
■ GT	650 Naked	GT650	03-05		☎				MCH 333 H1	
■ GT	650 R		05-		☎				MCH 334 H1	
■ GV	650 Aquila		06-09		☎					

Kawasaki

KX	80		91-00				MCH 901		MCH 139 H1	MCH 901
KX	85		01-11				MCH 901		MCH 139 H1	MCH 901
KX	85		12-						☎	
■ KMX	125	MX125A,MX125B	85-02		MCH 361 V1		MCH 901		MCH 450 H1	MCH 901
■ ZL	125 Eliminator	BN125A	97-03		MCH 378 V1		MCH 901			
■ KMX	200	MX200	88-89		MCH 361 V1		MCH 901		MCH 450 H1	MCH 901
■ BJ	250 Estrella	BJ250A	94-97		MCH 261 V1		MCH 901		MCH 450 H1	MCH 901
■ EL	250 Eliminator	EL250B/E	88-95		MCH 355 V1		MCH 901			
■	250 Ninja R	EX250K	08-13		MCH 854 V1		MCH 901		MCH 352 H1	MCH 901
■ KH	250	KH250B	76-77		MCH 105 V2		MCH 901			
■ KLR	250	KL250D	84-90		MCH 230 V1		MCH 901			
■ KLX	250 M		09-		MCH 855 V1		MCH 901		MCH 855 H1	MCH 901
KX	250		04		MCH 181 V1		MCH 901			
KX	250 F		06-		MCH 191 V1		MCH 901			
KX-F	250		04-		MCH 370 V1		MCH 901			
■ EL	252	EL250F	96-03		MCH 355 V1		MCH 901			
■	300 Ninja	EX300B	13-		MCH 898 V2		MCH 901			
■ GPZ	305	EX305A	84-89		MCH 356 V3		MCH 901			
■ GPZ	400 R	ZX400A	85-		MCH 363 V3		MCH 901		MCH 423 H1	MCH 901
■ KFX	400	AK47B	05-		☎				☎	
■ KH	400	S3F	76-77		MCH 105 V2		MCH 901			
■ Z	400	KZ400J	81-82		MCH 300 V3					
■ ZRX	400	ZR400E			MCH 449 V3		MCH 901			
■ ZXR	400	ZX400L	90-01		MCH 364 V3	MCH 951	MCH 901		MCH 371 H1	MCH 901
■ Z	440 LTD	KZ440A	80-84		MCH 263 V1		MCH 901			



Kawasaki

KX	450 F		06-		MCH 191 V1		MCH 901			
KXF	450		06-		MCH 370 V1		MCH 901			
■ Z	450 LTD	EN450A	85-89		MCH 431 V1		MCH 901			
■ EN	500	EN500A/B	90-95		MCH 365 V1		MCH 901			
■ EN	500	EN500C	96-03		MCH 358 V1		MCH 901			
■ ER-5	500 Twister	ER500A/B	96-00		MCH 382 V1		MCH 901			
■ ER-5	500 Twister	ER500C/D	01-06		MCH 382 V1		MCH 901			
■ GPZ	500 S	EX500A	86-87		MCH 302 V1		MCH 901			
■ GPZ	500 S	EX500A	88-91		MCH 354 V3		MCH 901			
■ GPZ	500 S	EX500A	92-93		MCH 309 V3		MCH 901			
■ GPZ	500 S	EX500D	94-96		MCH 339 V3	MCH 951	MCH 901		MCH 423 H1	MCH 901
■ GPZ	500 S	EX500E	97-03		MCH 339 V3	MCH 951	MCH 901		MCH 423 H1	MCH 901
■ KLE	500	LE500A	91-07		MCH 366 V1		MCH 901		MCH 374 H1	MCH 901
■ KX	500		89-91		MCH 367 V1		MCH 901			
■ Z	550 F	KZ550B	83-85		MCH 304 V3					
■ Z	550 LTD	KZ550C	80-81		MCH 311 V3		MCH 901			
■ Z	550 GT	KZ550G	83-89		MCH 303 V3		MCH 901			
■ Z	550	KZ550B	80-83		MCH 374 V3				MCH 139 H1	MCH 901
■ Z	550 GP	KZ550D	81		MCH 307 V5		MCH 901		MCH 334 H1	MCH 901
■ Z	550 GP	KZ550H	82-83		MCH 307 V5		MCH 901		MCH 334 H1	MCH 901
■ ZR	550 Zephyr	ZR550B	91-99		MCH 359 V3	MCH 951	MCH 901		MCH 359 H1	MCH 901
■ GPX	600 R	ZX600C	88-90		MCH 305 V3		MCH 901			
■ GPX	600 R	ZX600C	94-96		MCH 305 V3		MCH 901		MCH 450 H1	MCH 901
■ GPX	600 R	ZX600C	97-00		MCH 155 V3	MCH 951	MCH 901		MCH 450 H1	MCH 901
■ GPZ	600 R	ZX600A	85-89		MCH 341 V5		MCH 901		MCH 352 H1	MCH 901
■ KLR	600	KL600A	84		MCH 230 V1		MCH 901			
■ KLR	600	KL600B	85-86		MCH 230 V1		MCH 901			
■ KLR	600	KL600B	87-89		MCH 368 V1		MCH 901			
■ ZL	600 Eliminator	ZL600B	95-97		MCH 378 V1		MCH 901			
■ ZX-6R	600 Ninja	ZX600F	95-97		MCH 377 V3	MCH 951	MCH 901		MCH 423 H1	MCH 901
■ ZX-6R	600 Ninja	ZX600G	98-99		MCH 314 V3	MCH 951	MCH 901		MCH 314 H1	MCH 901
■ ZX-6R	600 Ninja	ZX600H	00-01	++	MCH 385 V2		MCH 901		MCH 383 H1	MCH 901
■ ZX-6R	600 Ninja	ZX600P	07-08		MCH 839 V2	MCH 951	MCH 901		MCH 116 H1	MCH 901
■ ZX-6R	600 Ninja	ZX600R	09-13		MCH 859 V2	MCH 951	MCH 901		MCH 859 H1	MCH 901
■ ZZR	600	ZX600D	90-92		MCH 351 V3	MCH 951	MCH 901		MCH 423 H1	MCH 901
■ ZZR	600 E	ZX600E	93-05		MCH 351 V3	MCH 951	MCH 901		MCH 423 H1	MCH 901
■ ZX-6R	636	ZX600A	02	++	MCH 385 V2		MCH 901		MCH 383 H1	MCH 901
■ ZX-6R	636	ZX636B	03-04		MCH 388 V2	MCH 951	MCH 901		MCH 388 H1	MCH 901
■ ZX-6R	636	ZX636C	05-06	++/ +	MCH 396 V2				MCH 193 H1	MCH 901
■ ER-6	650 N	ER650A	05-08		MCH 398 V2	MCH 951	MCH 901		MCH 398 H1	MCH 901
■ ER-6	650 F	ER650A	06-08		MCH 398 V2	MCH 951	MCH 901		MCH 398 H1	MCH 901
■ ER-6	650 N, F ABS	ER650A	06-08		MCH 847 V5		MCH 901		MCH 847 H2	MCH 901
■ KLR	650	KL650A	87-88		MCH 368 V1		MCH 901		MCH 145 H1	MCH 901
■ KLR	650	KL650B	89-90		MCH 369 V1		MCH 901		MCH 312 H1	MCH 901
■ KLR	650	KL650B	91-92		MCH 370 V1		MCH 901		MCH 312 H1	MCH 901
■ KLR	650	KL650C	95-04		MCH 230 V1		MCH 901		MCH 312 H1	MCH 901
■ KLX	650	KLX650C	93-94		MCH 376 V1		MCH 901		MCH 204 H1	MCH 901
■ W	650	EJ650A	99-02		MCH 463 V1		MCH 901			
■ W	650	EJ650A1	01-06	~	MCH 107 V1		MCH 901			
■ Z	650	B	77-79	*	MCH 330 V3					
■ Z	650	KZ650D	79-80		MCH 141 V3				MCH 312 H1	MCH 901
■ Z	650	KZ650F	81-83		MCH 342 V3					
■ Z	650	KZ650C	78-79		MCH 339 V3				MCH 312 H1	MCH 901
KFX	700	SV700A	05-							
■ GPX	750 Anti Dive	ZX750F	87-90		MCH 319 V3				MCH 334 H1	MCH 901
■ GPZ	750	ZX750A	83-85		MCH 318 V5				MCH 233 H1	MCH 901
■ GPZ	750	ZX750A	85-		MCH 324 V3				MCH 340 H1	MCH 901
■ GPZ	750 R	ZX750G	85-	Anti Dive	MCH 317 V5		MCH 901		MCH 334 H1	MCH 901
H2	750		72-73							
■ VN	750	VN750A	86-89		MCH 375 V3	MCH 951	MCH 901			
■ VN	750	VN750A	93-95		MCH 375 V3		MCH 901			



++/ + inkl. aller Schrauben – incl. bolts
 ++ inkl. Doppelhohlschraube – incl. doublebolt
 * Umbau auf Doppelbremse – double disc

Edelstahl poliert – stainless steel polished
 ohne Verteiler – without distributor
 Doppelzündung – Twin Spark

Flachlenker – Flatbar
 Hochlenker – Highbar
 BASIC Ohne Leitungen unter dem Tank – Without hoses under fuel tank



Kawasaki

■ Z	750	KZ750E	80-82		MCH 325 V3		MCH 901	MCH 438 H1	MCH 901
■ Z	750	ZR750J	04-06		MCH 392 V2	MCH 951	MCH 901	MCH 389 H1	MCH 901
■ Z	750	ZR750L	07-10		MCH 392 V2	MCH 951	MCH 901	MCH 463 H1	MCH 901
■ Z	750 S	ZR750J	05-06		MCH 397 V2	MCH 951	MCH 901	MCH 389 H1	MCH 901
■ Z	750 ABS	ZR750L	07-10		MCH 867 V3			MCH 867 H2	
■ Z	750 ABS	ZR750N	11-12		MCH 896 V3				
■ Z	750 GT	KZ750E	82-		MCH 313 V3			MCH 338 H1	MCH 901
■ Z	750 LTD	KZ750H	81-82		MCH 316 V3		MCH 901		
■ Z	750 LTD	KZ750K	83-86		MCH 316 V3		MCH 901		
Z	750 B3		78						
■ ZR	750 Zephyr	ZR750C	91-95		MCH 359 V3	MCH 951	MCH 901	MCH 359 H1	MCH 901
■ ZR	750 Zephyr	ZR750D	96-98		MCH 359 V3	MCH 951	MCH 901	MCH 359 H1	MCH 901
■ ZR-7	750	ZR750F	99-03		MCH 343 V3	MCH 951	MCH 901	MCH 470 H1	MCH 901
■ ZR-7	750 S	ZR750F	01-03		MCH 343 V3	MCH 951	MCH 901	MCH 470 H1	MCH 901
■ ZX	750	ZX750E	84-85		MCH 321 V5	MCH 951	MCH 901	MCH 233 H1	MCH 901
■ ZX-7R	750 Ninja	ZX750N	96-02		MCH 380 V3	MCH 951	MCH 901	MCH 357 H1	MCH 901
■ ZXR	750 R	ZX750H	89		MCH 320 V3			MCH 320 H1	MCH 901
■ ZXR	750 R	ZX750H	90		MCH 252 V3		MCH 901	MCH 357 H1	MCH 901
■ ZXR	750	ZX750J	91-95		MCH 371 V3	MCH 951	MCH 901	MCH 371 H1	MCH 901
■ ZXR	750 RR	ZX750K	92-95		MCH 371 V3	MCH 951	MCH 901	MCH 371 H1	MCH 901
■ VN	800	VN800A	95-00		MCH 358 V1		MCH 901		
■ VN	800 Classic	VN800B	96-05		MCH 310 V1		MCH 901		
■ VN	800 Drifter	VN800C	99-03		MCH 384 V1		MCH 901	MCH 384 H1	MCH 901
■ W	800	EJ800A	11-		MCH 378 V1		MCH 901		
■ Z	800		13-	Basic	MCH 899 V3			MCH 899 H2	
■ GPZ	900 R	ZX900A	84-89	Anti Dive	MCH 317 V5			MCH 334 H1	MCH 901
■ GPZ	900 R	ZX900A	90-93		MCH 353 V3			MCH 353 H1	MCH 901
■ VN	900 Classic	VN900B	06-11		MCH 825 V1		MCH 901	MCH 825 H1	MCH 901
VN	900 Classic	VN900B	12-						
■ VN	900 Custom	VN900C	07-11		MCH 825 V1		MCH 901	MCH 825 H1	MCH 901
■ Z	900	Z1F	74-76		MCH 329 V3				
■ Z	900 A4	Z1F089	76-		MCH 328 V3				
■ ZL	900				MCH 372 V3		MCH 901	MCH 212 H1	MCH 901
■ ZX-9R	900 Ninja	ZX900B	94-97		MCH 373 V3	MCH 951	MCH 901	MCH 373 H1	MCH 901
■ ZX-9R	900 Ninja	ZX900C/D	98-99		MCH 383 V3	MCH 951	MCH 901	MCH 383 H1	MCH 901
■ ZX-9R	900 Ninja	ZX900E	00-01	++	MCH 385 V2		MCH 901	MCH 383 H1	MCH 901
■ ZX-9R	900 Ninja	ZX900F	02-04	++	MCH 387 V2		MCH 901	MCH 383 H1	MCH 901
■ GPZ	1000 RX	ZXT00A	86-		MCH 341 V5			MCH 352 H1	MCH 901
■ GTR	1000	ZGT00A	86-89		MCH 121 V3			MCH 340 H1	MCH 901
■ GTR	1000	ZGT00A	90-94		MCH 312 V3	MCH 951	MCH 901	MCH 340 H1	MCH 901
■ GTR	1000	ZGT00A	96-03		MCH 322 V3	MCH 951	MCH 901	MCH 340 H1	MCH 901
■ KLV	1000	LV1000A	04-06	++	MCH 288 V2		MCH 901	MCH 288 H1	MCH 901
■ Z	1000	KZT00A	77		MCH 336 V3			MCH 352 H1	MCH 901
■ Z	1000	KZT00A	78		MCH 335 V3			MCH 335 H1	MCH 901
■ Z	1000	KZT00J	81-82		MCH 342 V3			MCH 438 H1	MCH 901
■ Z	1000	ZRT00A	03-06		MCH 389 V2	MCH 951	MCH 901	MCH 389 H1	MCH 901
■ Z	1000 ABS	ZRT00B/C	07-09		MCH 875 V5		MCH 901	MCH 875 H2	MCH 901
■ Z	1000 ABS	ZRT00D	10-		MCH 892 V5			MCH 893 H2	
■ Z	1000 LTD	KZT00J	81-		MCH 344 V3		MCH 901	MCH 438 H1	MCH 901
■ Z	1000 MK2	KZT00A	79-80		MCH 331 V3		MCH 901	MCH 139 H1	MCH 901
■ Z	1000 R2	KZT00R	83-84		MCH 342 V3		MCH 901	MCH 342 H1	MCH 901
■ Z	1000 ST	KZT00E	79-80		MCH 337 V3		MCH 901	MCH 359 H1	MCH 901
■ Z	1000 SX ABS	ZXT00H	11-		MCH 893 V5			MCH 893 H2	
■ Z	1000 Z1R	KZT00D	78-80		MCH 333 V3			MCH 333 H1	MCH 901
■ ZL	1000	ZLT00A	87-88		MCH 338 V3			MCH 212 H1	MCH 901
■ ZX-10R	1000	ZXT00B	88-90		MCH 334 V3			MCH 334 H1	MCH 901
■ ZX-10R	1000 Ninja	ZXT00C	04-05		MCH 393 V2	MCH 951	MCH 901	MCH 185 H1	MCH 901
■ ZX-10R	1000 Ninja	ZXT00D	06-07		MCH 399 V2	MCH 951	MCH 901	MCH 438 H1	MCH 901
■ ZX-10R	1000 Ninja	ZXT00E	08-14	++	MCH 842 V2		MCH 901	MCH 842 H1	MCH 901
■ ZX-10R	1000 Ninja ABS	ZXT00J	11-14	Basic	MCH 891 V4			MCH 891 H2	
■ GPZ	1100	ZXT10A	83-85		MCH 345 V5		MCH 901	MCH 334 H1	MCH 901
■ GPZ	1100	ZXT10E	95-98		MCH 379 V3	MCH 951	MCH 901	MCH 379 H1	MCH 901
■ Z	1100 GP	KZT10B	81-82		MCH 349 V3			MCH 423 H1	MCH 901
■ Z	1100 ST	KZT10A	81-83		MCH 348 V3		MCH 901	MCH 438 H1	MCH 901
■ ZR	1100 Zephyr	ZRT10A	92-93		MCH 360 V3		MCH 901	MCH 360 H1	MCH 901
■ ZR	1100 Zephyr	ZRT10A	94-95		MCH 360 V3		MCH 901	MCH 438 H1	MCH 901



Kawasaki

■ ZR	1100 Zephyr	ZRT10B	96-97			MCH 360 V3		MCH 901		MCH 438 H1	MCH 901
■ ZRX	1100	ZRT10C	97-00			MCH 362 V3	MCH 951	MCH 901		MCH 362 H1	MCH 901
■ ZZR	1100	ZXT10C	90-92			MCH 352 V3	MCH 951	MCH 901		MCH 352 H1	MCH 901
■ ZZR	1100	ZXT10D,G	93-01			MCH 306 V3	MCH 951	MCH 901		MCH 312 H1	MCH 901
■ ZG	1200		89-98			MCH 308 V3				MCH 357 H1	
■ ZRX	1200 R, S	ZRT20A	01-03			MCH 362 V3	MCH 951	MCH 901		MCH 340 H1	MCH 901
■ ZRX	1200 R, S	ZRT20B	04-			MCH 395 V3	MCH 951	MCH 901		MCH 340 H1	MCH 901
■ ZX-12	1200	ZXT20A	00-03	++		MCH 386 V2		MCH 901		MCH 386 H1	MCH 901
■ ZX-12	1200	ZXT20B	04-06	++		MCH 394 V2		MCH 901		MCH 386 H1	MCH 901
■ ZZR	1200	ZXT20C	02-05			MCH 357 V3	MCH 951	MCH 901		MCH 282 H1	MCH 901
■ Z	1300	KZT30A	79-85			MCH 350 V3		MCH 901		MCH 233 H1	MCH 901
■ Z	1300 DFI	ZGT30A	84-89			MCH 372 V3		MCH 901		MCH 300 H1	MCH 901
Z	1300 Voyager										
ZZR	1400	ZXT40A/C	06-							MCH 212H1	MCH 901
■ ZZR	1400 ABS	ZXT40E	06-								
■ VN	1500	VNT50A,B,C	87-95			MCH 358 V1		MCH 901		MCH 358 H1	MCH 901
■ VN	1500 Classic	VNT50D	96-02			MCH 381 V1		MCH 901		MCH 310 H1	MCH 901
■ VN	1500 Classic Tourer	VNT50G	98-02			MCH 315 V3		MCH 901			MCH 901
■ VN	1500 Classic Tourer	VNT50G	03-04			MCH 391 V3		MCH 901			
■ VN	1500 Drifter	VNT50J	99-03			MCH 384 V1		MCH 901		MCH 310 H1	MCH 901
■ VN	1500 Mean Streak	VNT50P	02-03	++		MCH 390 V2		MCH 901		MCH 310 H1	MCH 901
■ VN	1600 Classic	VNT60A	03-06			MCH 326 V3		MCH 901			
■ VN	1600 Classic Tourer	VNT60A	05-08					MCH 901			MCH 901
■ VN	1600 Mean Streak	VNT60B	04-08	++		MCH 390 V2		MCH 901		MCH 310 H1	MCH 901
VN	1700 Classic		09-								
■ VN	2000		04-09			MCH 327 V3		MCH 901		MCH 327 H1	MCH 901
■ VN	2000 Classic	VNW00A	08-10			MCH 327 V3		MCH 901		MCH 327 H1	MCH 901

KTM

■ SX	85		04-09			MCH 431 V1				MCH 204 H1	
■	125 LC2		96-99			MCH 711 V1		MCH 911			
■	125 Sting	KTM 125	97-99			MCH 712 V1		MCH 911		MCH 710 H1	MCH 911
■ EXC	125	KTM-2T-EXC	91-95	Grimeca		MCH 710 V1		MCH 911		MCH 710 H1	MCH 911
■ EXC	125	KTM-2T-EXC	95-97			MCH 711 V1		MCH 911			
■ EXC	125	KTM-2T-EXC	00-09			MCH 114 V1		MCH 911		MCH 114 H1	MCH 911
■ SX	125		00-09			MCH 114 V1				MCH 114 H1	MCH 911
■ EXC	200		00-04			MCH 114 V1		MCH 911		MCH 114 H1	MCH 911
■ EXC	250		91-95	Grimeca		MCH 710 V1		MCH 911		MCH 710 H1	MCH 911
■ EXC	250		95-97			MCH 711 V1		MCH 911			
■ EXC	250		00-09			MCH 114 V1		MCH 911		MCH 114 H1	MCH 911
■ SX	250		00-09			MCH 114 V1				MCH 114 H1	MCH 911
■ EXC	300		91-95	Grimeca		MCH 710 V1		MCH 911		MCH 710 H1	MCH 911
■ EXC	300		95-97			MCH 711 V1		MCH 911			
■ EXC	300		00-04			MCH 114 V1		MCH 911		MCH 114 H1	MCH 911
■ EXC	360		95-97			MCH 711 V1		MCH 911			
■ EXC	380		00-04			MCH 114 V1		MCH 911		MCH 114 H1	
■ SX	380		00-04			MCH 114 V1				MCH 114 H1	
■ EXC	400		95-97			MCH 711 V1		MCH 911			
■ LC4	400		92-97			MCH 714 V1		MCH 911		MCH 710 H1	
■ LC4	400	KTM-4G-EGS	97-98			MCH 713 V1		MCH 911		MCH 712 H1	MCH 911
■ LC4	400 Duke Modelle		94-98			MCH 712 V1		MCH 911		MCH 712 H1	MCH 911
■ SX	400		00-04			MCH 114 V1		MCH 911		MCH 114 H1	
■ EXC	440		95-97			MCH 711 V1		MCH 911			
■ SX	520		00-05			MCH 114 V1		MCH 911		MCH 114 H1	
■ LC4	620		92-97			MCH 714 V1		MCH 911		MCH 710 H1	
■ LC4	620 Adventure		97-98			MCH 713 V1		MCH 911		MCH 712 H1	MCH 911
■ LC4	620 Duke		94-98			MCH 712 V1		MCH 911		MCH 712 H1	MCH 911
■ LC4	625		02-			MCH 114 V1		MCH 911		MCH 712 H1	MCH 911
■ LC4	640 Duke		94-98			MCH 712 V1		MCH 911		MCH 712 H1	MCH 911
■ LC4	640 Supermoto		99-			MCH 713 V1		MCH 911			



++/+ inkl. aller Schrauben – incl. bolts
 ++ inkl. Doppelhohlschraube – incl. doublebolt
 * Umbau auf Doppelbremse – double disc

☐ Edelstahl poliert – stainless steel polished
 ✳ ohne Verteiler – without distributor
 2⚡ Doppelzündung – Twin Spark

~ Flachlenker – Flatbar
 ~ Hochlenker – Highbar
 BASIC Ohne Leitungen unter dem Tank – Without hoses under fuel tank



Kymco

■	50 Cobra	SF10	97-00		MCH 804 V1				
■	50 Top Boy	SF10	01-06		MCH 804 V1				
■	100 Top Boy Racer		01-02		MCH 804 V1				
■	125 Stryker	AF	01-04		MCH 556 V1				
■	125 Zing	RF25	97-00		MCH 556 V1				
■	KXR 250 Sport		04-		☎			☎	

Laverda

■	1000 SFC		86-88		MCH 850 V3			MCH 210 H1	
■	1200		78-80		MCH 850 V3			MCH 423 H1	

Malaguti

■	F-12 50 Phantom	ZJM40/D	94-96		MCH 501 V1	MCH 911			
---	-----------------	---------	-------	--	------------	---------	--	--	--

MBK

■	YN 50 Ovetto	5AD	96-06		MCH 706 V1				
■	YP 50 Nitro	SA14	97-06		MCH 716 V1				
■	YN 100 Ovetto	SB04	96-06		MCH 706 V1				
■	YP 100 Nitro	SB05	97-02		MCH 716 V1				
■	YW 100 Booster	SB02	01-06		MCH 706 V1				
■	YP 125 Skyliner	5DS	97-00		MCH 703 V1				
■	YP 125 Skyliner	SE06	01-06		MCH 703 V1				
■	XQ 125 Thunder	SE05	01-02		MCH 703 V1				

Moto Guzzi

■	V 650 65 SP		81-85		MCH 643 V4	MCH 911			
■	V 750 Florida		88-93		MCH 642 V3				
■	750 Nevada		00-		☎			MCH 254 H1	MCH 911
■	850 Le Mans		76-84		MCH 632 V4	MCH 911			
■	850 T3		75-83		MCH 641 V5				
■	1000 California II		81		MCH 630 V4	MCH 911			
■	1000 Convert		75-		☎	MCH 911			
■	1000 Le Mans IV		85-88		MCH 631 V4	MCH 911			
■	1000 Le Mans IV		89-91		MCH 633 V5	MCH 911			
■	1000 Le Mans V		92-		MCH 634 V4	MCH 911			
■	1000 Mille GT		87-		☎	MCH 911			
■	1000 Quota		92-		☎	MCH 911			
■	1000 California II	VT	82-87		MCH 635 V5				
■	1000 California III	VW	88-		MCH 636 V4	MCH 911			
■	1000 S	VV	90-		MCH 637 V4	MCH 911			
■	V 1000 SP II		88-		MCH 640 V4	MCH 911			
■	V 1000 G5	VG	78-81		MCH 639 V5				
■	V 1000 SP I	VG-SP	78-87		MCH 638 V4	MCH 911			
■	1100 California Jackel	KD	00-01		☎				
■	EV 1100 California	KD	97-		MCH 645 V2				
■	EV 1100 California I.E.	KC/KD	94-96		MCH 644 V4	MCH 911			

Moto Morini

■	500 Touring		79		MCH 438 V3			MCH 256 H1	
■	500 Touring		80-		MCH 438 V3			MCH 352 H1	
■	3 1/2 Touring		79		MCH 438 V3			MCH 256 H1	
■	3 1/2 Touring		80-		MCH 438 V3			MCH 352 H1	

MUZ

■	MZ 660	MKZ660E	98-04		☎				
---	--------	---------	-------	--	---	--	--	--	--

MV Agusta

■	F4 750 F4	F4	99-	++	☎				
■	1000 F4		04-	++	☎				

MZ

■	ETZ 125		87-		MCH 700 V1				
■	ETZ 250	ETZ250	87-		MCH 700 V1				

Piaggio

■	RST 50 Sfera	C01	95-		MCH 708 V1	MCH 911			
■	TPH 50 Thyhoon	TEC	93-		MCH 709 V1	MCH 911			
■	125 Sfera	M01	95-		MCH 708 V1	MCH 911			



Piaggio

■	125 Skipper	CSM	94-98		MCH 715 V1	MCH 911				
■	125 Thyhoon	M02			MCH 708 V1	MCH 911				
■ SKR	125	CSM	94-98		MCH 715 V1	MCH 911				
■	150 Skipper		94-98		MCH 715 V1	MCH 911				
■ SKR	150	CSM	94-98		MCH 715 V1	MCH 911				

Suzuki

■ AY	50 Katana	AA	97-04		MCH 281 V1	MCH 921				
■ RG	80	NC11A	87-96		MCH 407 V1	MCH 921				
■ RM	80	RC12A	89-01		MCH 206 V1	MCH 921		MCH 139 H1	MCH 921	
	RM	85	02-04					MCH 139 H1	MCH 921	
■ DR	125	SF44A	91-99		MCH 114 V1	MCH 921				
■ GN	125 R	NF41A	95-00		MCH 263 V1	MCH 921				
■ GS	125 ES	AW	99-00		MCH 200 V1	MCH 921				
■ GZ	125 Marauder	AP	98-99		MCH 253 V1	MCH 921				
■ GZ	125 Marauder	AP	02-05		MCH 253 V1	MCH 921				
■ RG	125 Gamma		87-		MCH 200 V1	MCH 921				
■ RM	125	RF15A	96-00		MCH 178 V1					
	RM	125	04		MCH 370 V1					
	RM	125	05-06		MCH 191 V1					
	RM-Z	125	04		MCH 370 V1					
	RM-Z	125	05-06		MCH 191 V1					
■ TU	125 XT	AZ	99-00		MCH 462 V1	MCH 921				
■ UH	125 Burgman	BP	02-		MCH 804 V1					
■ VL	125 Intruder LC	A4	99-07		MCH 213 V1	MCH 901	MCH 921			
■ GN	250 E	NJ42A	82-99		MCH 263 V1	MCH 921				
■ GT	250 E	GT2502	78-81		MCH 168 V1	MCH 921				
■ GZ	250 Marauder	AR	99-04		MCH 253 V1	MCH 921				
■ RG	250 Gamma	GJ21B	86-		MCH 202 V3	MCH 971	MCH 921	MCH 202 H1	MCH 921	
■ RGV	250	VJ21A	88-90		MCH 203 V3	MCH 971	MCH 921	MCH 203 H1	MCH 921	
■ RGV	250	VJ22B	91-93		MCH 258 V3	MCH 971	MCH 921		MCH 921	
■ RM	250	RJ14A	96-00		MCH 178 V1					
	RM	250	04		MCH 370 V1					
	RM	250	05-08		MCH 191 V1					
	RM-Z	250	04		MCH 370 V1					
	RM-Z	250	05-07		MCH 191 V1					
■ DR	350 S	SK42B	90-94		MCH 201 V1	MCH 921		MCH 201 H1	MCH 921	
■ DR	350 SE	SK42B	95-97		MCH 201 V1	MCH 921		MCH 201 H1	MCH 921	
■ GT	380	GT380	73-77		MCH 256 V1	MCH 921				
	AN	400 Burgman	WVAU							
■ DR-Z	400 S	WVBC	00-06		MCH 237 V1	MCH 901		MCH 237 H1	MCH 901	
■ DR-Z	400 SM	WVB8	05-08		MCH 237 V1	MCH 901			MCH 901	
■ GN	400 L	GN400	81-84		MCH 153 V1	MCH 921				
■ GN	400 TD	GN400	80-84		MCH 263 V1	MCH 921				
■ GS	400 E	GS400	77-79		MCH 205 V2					
	GS	400 D	83		MCH 205 V2					
■ GS	400 T				MCH 302 V1	MCH 921				
■ GSF	400 Bandit	GK75B	91-96		MCH 260 V3	MCH 971	MCH 921	MCH 260 H1	MCH 921	
■ GSX	400 S	GS40X	80-81		MCH 513 V1	MCH 921				
■ GSX	400 F	GS40XF	81-84		MCH 204 V3	MCH 971	MCH 921			
■ GSXR	400	GK76A	91-97	++	MCH 273 V2	MCH 921		MCH 208 H1	MCH 921	
	LT-Z	400 Quad Sport	AK	03-						
■ GS	450 E	GS450	79-		MCH 302 V1	MCH 921				
■ GS	450 L	GS450	80-87		MCH 153 V1	MCH 921				
■ GS	450 T	GS450	80-82		MCH 263 V1	MCH 921				
	RM	450	05-06		MCH 191 V1					
	RMZ	450	05-13		MCH 191 V1					
■ GS	500 E	GS500E	79-		MCH 217 V3	MCH 971	MCH 921			
■ GS	500 E	GM51B	89-93		MCH 261 V1	MCH 901	MCH 921	MCH 263 H1	MCH 921	
■ GS	500 E	GM51B	94-04		MCH 228 V1	MCH 901	MCH 921	MCH 263 H1	MCH 921	
■ GS	500 F	WVBK	04-08		MCH 228 V1	MCH 901	MCH 921	MCH 263 H1	MCH 921	
■ RG	500 Gamma	HM31A	85-89		MCH 207 V3	MCH 921		MCH 124 H1	MCH 921	



++/+ inkl. aller Schrauben – incl. bolts
 ++ inkl. Doppelhohlschraube – incl. doublebolt
 * Umbau auf Doppelbremse – double disc

☐ Edelstahl poliert – stainless steel polished
 ✳ ohne Verteiler – without distributor
 2⚡ Doppelzündung – Twin Spark

~ Flachlenker – Flatbar
 ~ Hochlenker – Highbar
 BASIC Ohne Leitungen unter dem Tank – Without hoses under fuel tank



Suzuki

■ GS	550 M	GS550M	83-84		MCH 216 V5				MCH 240 H1	MCH 921	
■ GS	550 E	GS550	79-		MCH 217 V3	MCH 971	MCH 921				
■ GSX	550 ES	GN71D	83-87		MCH 209 V3	MCH 971	MCH 921		MCH 212 H1	MCH 921	
■ GSX	550 EF,ES	GN71D	83-84	Anti Dive	MCH 212 V5				MCH 212 H1	MCH 921	
■ DR	600 S, SU	SN41A	85-89		MCH 230 V1		MCH 921				
■ GSF	600 Bandit	GN77B	95-99		MCH 268 V3	MCH 971	MCH 901	MCH 921	MCH 212 H1	MCH 921	
■ GSF	600 Bandit	WVA8	00-04		MCH 282 V3	MCH 971	MCH 901	MCH 921	MCH 282 H1	MCH 921	
■ GSF	600 S Bandit	GN77B	96-99		MCH 270 V3	MCH 971	MCH 901	MCH 921	MCH 212 H1	MCH 921	
■ GSF	600 S Bandit	WVA8	00-04		MCH 283 V3	MCH 971	MCH 901	MCH 921	MCH 282 H1	MCH 921	
■ GSR	600	WVB9	06-09		MCH 822 V2	MCH 951	MCH 901		MCH 334 H1	MCH 901	
■ GSR	600 ABS	WVB9	07-08	Basic	MCH 849 V3		MCH 901		MCH 849 H2	MCH 901	
■ GSX	600 F	GN72B	88-97		MCH 214 V3	MCH 971	MCH 921		MCH 214 H1	MCH 921	
■ GSX	600 F	WVAJ	98-01		MCH 208 V3	MCH 971	MCH 901	MCH 921	MCH 208 H1	MCH 901	MCH 921
■ GSXR	600	AD311	97-00		MCH 224 V2	MCH 951	MCH 901	MCH 921	MCH 224 H1	MCH 921	
■ GSXR	600	WVBG	01-03		MCH 282 V2	MCH 951	MCH 901	MCH 921	MCH 206 H1	MCH 921	
■ GSXR	600	WVB2	04-05		MCH 296 V2	MCH 951	MCH 901		MCH 353 H1	MCH 901	
■ GSXR	600	CE	06-07		MCH 821 V2	MCH 951	MCH 901		MCH 821 H1	MCH 901	
■ GSXR	600	CV	08-10		MCH 821 V2	MCH 951	MCH 901		MCH 821 H1	MCH 901	
■ GSXR	600	C3	11-14		MCH 880 V2	MCH 951	MCH 901		MCH 880 H1	MCH 901	
■ RF	600 R, RU	GN76B	93-96		MCH 271 V3	MCH 971	MCH 901	MCH 921	MCH 226 H1	MCH 921	
■ VS	600 Intruder	VN51B	95-97		MCH 223 V1		MCH 921				
■ DL	650 V-Strom	WVB1	04-06	++	MCH 297 V2				MCH 297 H1		
■ DL	650 V-Strom ABS	WVB1	07-11		MCH 874 V5				MCH 874 H2		
■ DR	650 R, RU	SP41B, SP42B	90-91		MCH 255 V1		MCH 921		MCH 255 H1	MCH 921	
■ DR	650 R	SP43B	91-96		MCH 368 V1		MCH 921		MCH 368 H1	MCH 901	
■ DR	650 R, RU	SP44B, SP45B	92-95		MCH 255 V1		MCH 921		MCH 255 H1	MCH 921	
■ DR	650 SE, RSE	SP46B	96-99		MCH 368 V1		MCH 921		MCH 368 H1	MCH 901	
■ GR	650 X	GP51A	83-89		MCH 263 V1		MCH 921				
■ GS	650 G	GS650G	81-82	Anti Dive	MCH 216 V5	MCH 971	MCH 921		MCH 240 H1	MCH 921	
■ GS	650 G	GS650G	81-82		MCH 204 V3	MCH 971	MCH 921		MCH 240 H1	MCH 921	
■ GSF	650 Bandit, S Bandit	WVB5	05-06		MCH 298 V2	MCH 951	MCH 901		MCH 284 H1	MCH 901	
■ GSF	650 Bandit ABS	WVB5	06		MCH 848 V5						
■ GSF	650 Bandit ABS	WVCJ	07-09		MCH 843 V3				MCH 851 H2		
■ GSX	650 F	WVCJ	08-		MCH 845 V2				MCH 845 H1	MCH 901	
■ LS	650 P Savage	NP41B	86-96		MCH 215 V1		MCH 921				
■ LS	650 P Savage	NP41B	97-00		MCH 276 V1		MCH 921				
■ SFV	650 Gladius	SFV	09-		MCH 865 V2				MCH 865 H1		
■ SFV	650 Gladius ABS	SFV	09-		MCH 869 V3		MCH 901		MCH 869 H2	MCH 901	
■ SV	650	AV111	99-02		MCH 279 V3	MCH 971	MCH 901	MCH 921	MCH 254 H1	MCH 921	
■ SV	650	WVBY	03-08	++	MCH 294 V2		MCH 901		MCH 101 H1	MCH 901	
■ SV	650 S	AV111	99-02		MCH 278 V3	MCH 971	MCH 901	MCH 921	MCH 353 H1	MCH 921	
■ SV	650 S	WVBY	03-08	++	MCH 293 V2		MCH 901		MCH 293 H1	MCH 901	
■ SV	650 ABS	WVBY	07-08		MCH 858 V3				MCH 858 H2		
■ XF	650 Freewind	AC	97-99		MCH 156 V1		MCH 901		MCH 205 H1	MCH 901	MCH 921
■ XF	650 Freewind	AC	00-02		MCH 170 V1		MCH 901		MCH 205 H1	MCH 901	MCH 921
■ DR	750 S,SU	SR41B	88		MCH 230 V1		MCH 921				
■ DR	750 S,SU	SR41B	89-90		MCH 230 V1		MCH 921		MCH 110 H1	MCH 921	
■ GS	750 D	GS750D	77-79		MCH 204 V3						
■ GSR	750	C5	11-		MCH 876 V2	MCH 951	MCH 901		MCH 204 H1	MCH 901	
■ GSR	750 ABS	C5	11-		MCH 894 V3				MCH 894 H2		
■ GSX	750 E	GS75X	80-82		MCH 264 V3				MCH 210 H1	MCH 921	
■ GSX	750 ES	GR72A	85		MCH 235 V5				MCH 210 H1	MCH 921	
■ GSX	750 L	GS75X	80-81		MCH 231 V3						
■ GSX	750 S	GR71A	82-						MCH 210 H1	MCH 921	
■ GSX	750	AE	98-01		MCH 274 V3	MCH 971	MCH 901	MCH 921	MCH 200 H1	MCH 921	
■ GSX	750 ES,EF	GR72A	83-85	Anti Dive	MCH 219 V5				MCH 219 H1	MCH 921	
■ GSX	750 F	GR78A	89-97		MCH 254 V3	MCH 971	MCH 921		MCH 254 H1	MCH 921	
■ GSX	750 F	WVAK	99-06		MCH 218 V3	MCH 971	MCH 921	MCH 901	MCH 208 H1	MCH 901	MCH 921
■ GSX	750 S m.A.	GR71A	82-		MCH 246 V5				MCH 210 H1	MCH 921	
■ GSXR	750	GR75A	85-87		MCH 234 V3		MCH 921		MCH 233 H1	MCH 921	
■ GSXR	750	GR77B	88-89		MCH 233 V3		MCH 921		MCH 233 H1	MCH 921	
■ GSXR	750	GR7AB	90-91		MCH 252 V3	MCH 971	MCH 921		MCH 357 H1	MCH 921	
■ GSXR	750 W	GR7BB	92-93		MCH 265 V3	MCH 971	MCH 921		MCH 262 H1	MCH 921	
■ GSXR	750 W	GR7BB	94-95		MCH 224 V2	MCH 951	MCH 901	MCH 921	MCH 262 H1	MCH 921	
■ GSXR	750	GR7DB	96-99		MCH 224 V2	MCH 951	MCH 901	MCH 921	MCH 224 H1	MCH 921	
■ GSXR	750	WVBD	00-03		MCH 282 V2	MCH 951	MCH 901	MCH 921	MCH 240 H1	MCH 921	



Suzuki

■ GSXR	750	VVB3	04-05		MCH 296 V2	MCH 951	MCH 901		MCH 353 H1	MCH 901	
■ GSXR	750	CF	06-07		MCH 821 V2	MCH 951	MCH 901		MCH 821 H1	MCH 901	
■ GSXR	750	CW	08-10		MCH 821 V2	MCH 951	MCH 901		MCH 821 H1	MCH 901	
■ GSXR	750	C4	11-14		MCH 880 V2	MCH 951	MCH 901		MCH 880 H1	MCH 901	
■ GT	750	GT750	73-77		MCH 429 V3						
■ VS	750	Intruder GLF, GLP	VR51B	86-91	MCH 223 V1		MCH 921				
■ DR	800	S	SR42B	90	MCH 230 V1		MCH 921		MCH 257 H1	MCH 901	
■ DR	800	S	SR43B	91-98	MCH 230 V1		MCH 921		MCH 249 H1	MCH 901	
■ M	800	Intruder	WVB4	05-09	MCH 170 V1		MCH 901				
■ VL	800	Intruder LC Volusia	WVBM	01-06	MCH 239 V1		MCH 901				
■ VS	800	GL	VS52B	92-00	MCH 266 V1		MCH 921				
■ VX	800	U	VS51B	90-96	MCH 256 V1		MCH 921		MCH 256 H1	MCH 921	
■ VZ	800	Marauder	WVBM	97-04	MCH 213 V1		MCH 901				
■ GS	850	G	GS850	79-81	MCH 236 V3	MCH 971	MCH 921		MCH 210 H1	MCH 921	
■ GS	850	G	GS72A	84-88	MCH 236 V3	MCH 971	MCH 921		MCH 210 H1	MCH 921	
■ RF	900	R	GT73B	94-97	MCH 226 V3	MCH 971	MCH 921		MCH 226 H1	MCH 921	
■ DL	1000	V-Strom	WVBS	02-12	++	MCH 288 V2		MCH 901	MCH 288 H1	MCH 901	
■ DL	1000	V-Strom, ABS		14-	i.V				i.V		
■ GS	1000	E	GS1000	78-80		MCH 238 V3			MCH 265 H1	MCH 921	
■ GS	1000	G	GS100G	80-		MCH 240 V3			MCH 210 H1	MCH 921	
■ GS	1000	S	GS1000	79-81		MCH 349 V3	MCH 971	MCH 921	MCH 210 H1	MCH 921	
■ GSXR	1000		WVBL	01-02		MCH 285 V2	MCH 951	MCH 901	MCH 206 H1	MCH 901	MCH 921
■ GSXR	1000		WVBZ	03-04		MCH 290 V2	MCH 951	MCH 901	MCH 290 H1	MCH 901	
■ GSXR	1000		WVB6	05-06		MCH 299 V2	MCH 951	MCH 901	MCH 206 H1	MCH 901	
■ GSXR	1000		WVCL	07-08		MCH 299 V2	MCH 951	MCH 901	MCH 299 H1	MCH 901	
■ GSXR	1000		WVCY	09-11		MCH 861 V2	MCH 951	MCH 901	MCH 861 H1	MCH 901	
■ GSXR	1000		WVCY	12-14		MCH 895 V2	MCH 951	MCH 901	MCH 895 H1	MCH 901	
■ SV	1000		WVBX	03-07		MCH 295 V2	MCH 951	MCH 901	MCH 207 H1	MCH 901	
■ SV	1000	S	WVBX	03-07		MCH 257 V2	MCH 951	MCH 901	MCH 207 H1	MCH 901	
■ TL	1000	R	AM321	98-02		MCH 277 V2	MCH 951	MCH 901	MCH 921	MCH 133 H1	MCH 901
■ TL	1000	S	AG111	97-00		MCH 272 V2	MCH 951	MCH 901	MCH 921	MCH 272 H1	MCH 921
■ GS	1100	G	GU71A	86-88		MCH 240 V3	MCH 971	MCH 921		MCH 240 H1	MCH 921
■ GSX	1100	E	GV71C	85		MCH 245 V3				MCH 149 H1	MCH 921
■ GSX	1100	E,EF,ES	GV71C	84-		MCH 245 V3				MCH 233 H1	MCH 921
■ GSX	1100	ES	GV71B	83		MCH 247 V5				MCH 210 H1	MCH 921
■ GSX	1100	EX	GV71B	82-83		MCH 248 V5				MCH 210 H1	MCH 921
■ GSX	1100	E	GS110X	80-		MCH 249 V3	MCH 971	MCH 921		MCH 249 H1	MCH 921
■ GSX	1100	F	GV72C	88		MCH 243 V3		MCH 921		MCH 265 H1	MCH 921
■ GSX	1100	F	GV72C	89-96		MCH 225 V3		MCH 921		MCH 251 H1	MCH 921
■ GSX	1100	G	GV74A	91-96		MCH 262 V3				MCH 433 H1	MCH 921
■ GSX	1100	S Katana	GS1100X	82-85		MCH 246 V5	MCH 971	MCH 921		MCH 210 H1	MCH 921
■ GSXR	1100		GU74CD	86-88		MCH 242 V3		MCH 921		MCH 113 H1	MCH 921
■ GSXR	1100		GV73C	89-90		MCH 241 V3		MCH 921		MCH 320 H1	MCH 921
■ GSXR	1100		GV73C	91-92		MCH 259 V3		MCH 921		MCH 259 H1	MCH 921
■ GSXR	1100	W	GU75C	93-94		MCH 267 V2	MCH 951	MCH 921		MCH 267 H1	MCH 921
■ GSXR	1100	W	GU75C	95-97		MCH 267 V2	MCH 951	MCH 901	MCH 921	MCH 267 H1	MCH 921
■ GSF	1200	Bandit	GV75A	96-00		MCH 291 V3	MCH 971	MCH 921		MCH 212 H1	MCH 921
■ GSF	1200	SA, Bandit ABS	GV75A	96-00		MCH 222 V4		MCH 921		MCH 212 H1	MCH 921
■ GSF	1200	Bandit	WVA9	01-05		MCH 286 V3	MCH 971	MCH 901	MCH 921	MCH 284 H1	MCH 921
■ GSF	1200	Bandit	WVCB	06		MCH 823 V2	MCH 951	MCH 901		MCH 352 H1	MCH 901
■ GSF	1200	S, Bandit	GV75A	96-00		MCH 292 V3	MCH 971	MCH 921		MCH 212 H1	MCH 921
■ GSF	1200	S, Bandit	WVA9	01-05		MCH 284 V3	MCH 971	MCH 901	MCH 921	MCH 284 H1	MCH 921
■ GSF	1200	S, Bandit	WVCB	06		MCH 823 V2	MCH 951	MCH 901		MCH 352 H1	MCH 901
■ GSF	1200	Bandit ABS, SA Bandit ABS	WVCB	06		MCH 848 V5		MCH 901		MCH 851 H2	MCH 901
■ GSX	1200	FS	A3	99-00		MCH 211 V3	MCH 971	MCH 901	MCH 921	MCH 200 H1	MCH 921
■ GSF	1200	Bandit		07-		MCH 883 V2				MCH 883 H1	
■ GSF	1250	Bandit	WVCH	07-		MCH 883 V2				MCH 883 H1	
■ GSF	1250	Bandit ABS	WVCH	07-11		MCH 851 V5		MCH 901		MCH 851 H2	MCH 901
■ GSX	1250	F	WVCH	10-		MCH 885 V3				MCH 885 H1	
■ GSX	1300	R Hayabusa	A1	99-02		MCH 280 V2	MCH 951	MCH 901		MCH 256 H1	MCH 921
■ GSX	1300	R Hayabusa	WVCK	03-07		MCH 280 V2	MCH 951	MCH 901		MCH 256 H1	MCH 901
											MCH 921



++/+ inkl. aller Schrauben – incl. bolts
 ++ inkl. Doppelhohlschraube – incl. doublebolt
 * Umbau auf Doppelbremse – double disc

☑ Edelstahl poliert – stainless steel polished
 ✖ ohne Verteiler – without distributor
 2⚡ Doppelzündung – Twin Spark

⌒ Flachlenker – Flatbar
 ⌒ Hochlenker – Highbar
 BASIC Ohne Leitungen unter dem Tank – Without hoses under fuel tank



Suzuki

■	GSX	1300 R Hayabusa	WVCK	08-12		MCH 280 V2	MCH 951	MCH 901		MCH 121 H1	MCH 921
■	GSX	1300 B-King	WVCR	07-09		MCH 841 V2	MCH 951	MCH 901		MCH 841 H1	MCH 901
■	GSX	1300 B-King ABS	WVCR	08-09		MCH 852 V3	MCH 951	MCH 901		MCH 852 H2	MCH 901
■	GSX	1400	WVBN	01-07		MCH 287 V3	MCH 951	MCH 901		MCH 214 H1	MCH 901
■	VS	1400 Intruder	VX51L/LD	87-03		MCH 250 V1		MCH 921		MCH 264 H1	MCH 921
■	VL	1500 Intruder	AL	98-01		MCH 275 V1		MCH 901		MCH 275 H1	MCH 901
■	VL	1500 Intruder	WVAL	02-04		MCH 289 V2	MCH 951	MCH 901		MCH 275 H1	MCH 901
■	VL	1500 Intruder	WVAL	05-08		MCH 882 V2				MCH 882 H1	
■	VZ	1600 Marauder	VNT60B	04-05	++	MCH 390 V2		MCH 901			
■	VZR	1800 M 1800 R Intruder	WVCA	06-09		MCH 828 V3		MCH 901			

SYM

■		50 DD		02-07		MCH 457 V1					
		50 Shark		00-03							
■		125 Husky	N125A	97-		MCH 412 V1					

Triumph

■	TT	600	806AD	00-03						MCH 139 H1	
■		750 Trident	T300C	91-96		MCH 661 V3	MCH 951	MCH 901		MCH 661 H1	MCH 901
		750 Bonneville		78-79							
■		800 Bonneville, T100, America	908MD	02-06						MCH 265 H1	MCH 901
■		865 Scrambler		06-						MCH 481 H1	MCH 901
■		900 Thunderbird Sport	T309RD	98-99						MCH 335 H1	MCH 901
■		900 Adventurer	T309	96-01		MCH 215 V1		MCH 901		MCH 335 H1	MCH 901
■		900 Daytona	T300D	93-96		MCH 663 V3	MCH 951	MCH 901		MCH 662 H1	MCH 901
■		900 Legend	T309TR	95-		MCH 256 V1		MCH 901		MCH 139 H1	MCH 901
■		900 Speed Triple	T300B	94-96		MCH 663 V3	MCH 951	MCH 901		MCH 661 H1	MCH 901
■		900 Sprint	T300A	93-96		MCH 661 V3	MCH 951	MCH 901		MCH 661 H1	MCH 901
■		900 Thunderbird	T309RT	95-99		MCH 256 V1		MCH 901		MCH 335 H1	MCH 901
■		900 Tiger	T400	91-96		MCH 660 V3	MCH 951	MCH 901		MCH 249 H1	MCH 901
■		900 Trident	T300C	91-96		MCH 661 V3	MCH 951	MCH 901		MCH 661 H1	MCH 901
■		900 Trophy	T300E	91-96		MCH 661 V3	MCH 951	MCH 901		MCH 661 H1	MCH 901
■		955 Daytona	T595	97-98		MCH 664 V2				MCH 664 H1	
■		955 Speed Triple	T509	97-98		MCH 664 V2				MCH 664 H1	
■		955 Speed Triple	T509	99-						MCH 664 H1	
■		955 Sprint RS	T695A	02-04						MCH 145 H1	MCH 901
		955 Sprint ST	T695	99-04						MCH 265 H1	MCH 901
■		1200 Daytona	T300	93-96		MCH 663 V3	MCH 951	MCH 901		MCH 662 H1	MCH 901
■		1200 Trophy	T300	91-96		MCH 661 V3	MCH 951	MCH 901		MCH 661 H1	MCH 901
■		1200 Trophy	T300E	97-01						MCH 124 H1	MCH 901

Yamaha

■		50 Neos	5RN/1P9	96-06		MCH 706 V1		MCH 901			
■	BW	50 NG	4BXM	99-02		MCH 706 V1		MCH 901			
■	CW	50 RS	4CW1,4CW3	95-98		MCH 706 V1		MCH 901			
■	YQ	50 Aerox	5BR,SA14	97-09		MCH 716 V1					
■	DT	80 LC2	53V	85-		MCH 424 V1		MCH 901			
■	RD	80 LC		83-89		MCH 200 V1		MCH 901			
■	YQ	100 Aerox	SB05	97-		MCH 716 V1					
■	DT	125 LC	10V	84-87		MCH 369 V1		MCH 901			
■	DT	125 R	4BL,3RM,DE03	91-03		MCH 458 V1		MCH 901			
■	DT	125 RE	DE06	04-06		MCH 868 V1		MCH 901			
■	SR	125	3MW8	96-98		MCH 355 V1		MCH 901			
■	TDR	125	4GW1	93-01		MCH 170 V1		MCH 901		MCH 334 H1	MCH 901
■	TDR	125	5AN	99-		MCH 170 V1		MCH 901			MCH 901
■	TW	125 Trailway	DE01	99-		MCH 403 V1					
■	XQ	125 Maxter	SE05	01-03		MCH 703 V1					
■	XV	125 S, Virago	5AJ	97-00		MCH 263 V1		MCH 901			
■	XVS	125 Drag Star	VE01	01-03		MCH 256 V1		MCH 901			
■	YP	125 Majesty	SE02,SE06	97-06		MCH 703 V1		MCH 901			
■	YBR	125		05-11		MCH 382 V1		MCH 901			
■	YZ	125		89		MCH 455 V1		MCH 901			
■	YZ	125		90-91		MCH 418 V1		MCH 901			
■	YZ	125		96-97						MCH 224 H1	
■	YZ	125	4XM,CE10	98-04		MCH 482 V1				MCH 272 H1	
■	YZF	125	RE06	08-13		MCH 719 V1		MCH 901		MCH 719 H1	MCH 901
■	RD	250 LC	4L1, 4L2	80-83		MCH 486 H1		MCH 901			



Yamaha

■ RD	250	522	72-75						MCH 405 V2				
■ TDR	250	3CK1	88-90						MCH 513 V1				MCH 837 H1 MCH 901
■ TZ	250 GP		89-90						MCH 401 V2				
■ TZR	250	2MA, 2XW	87-90						MCH 400 V1	MCH 901			MCH 400 H1 MCH 901
WR	250 F	CG	01-09						MCH 427 V1				
WR	250 R		08-										
WR	250 X	DG20	08-										
XG	250 Tricker		06-										
■ XV	250 Virago	3LS, 3LW	89-97						MCH 457 V1	MCH 901			
■ XV	250 S, Virago	3LW	95-99						MCH 263 V1	MCH 901			
■ XVS	250 Drag Star	VG03	01-						MCH 256 V1	MCH 901			
■ YZ	250		89						MCH 455 V1	MCH 901			
■ YZ	250		90-91						MCH 418 V1				
■ YZ	250		96-97										MCH 224 H1
■ YZ	250	4XL	98-03						MCH 482 V1				MCH 272 H1
■ RD	350 LC	4L0	80-82						MCH 406 V3				
■ RD	350 LC, LCF	1WW, 1WX	86-90						MCH 109 V3	MCH 901			MCH 461 H1 MCH 901
■ RD	350 LC, YPVS	31K	83-85						MCH 406 V3	MCH 901			MCH 202 H1 MCH 901
TT	350		86-							MCH 901			
■ XT	350	55V,59Y	85-90						MCH 404 V1	MCH 901			
■ XT	350	3YT1,3YT3	91-95						MCH 404 V1	MCH 901			
YFM	350 R	YFM350	04-										MCH 113 H1
■ XS	360 SE	1U4	77-78						MCH 107 V1	MCH 901			
■ FZR	400 R	3TJ,4DX	91-						MCH 461 V3	MCH 951 MCH 901			
■ RD	400	1A3	76-78						MCH 107 V1				
SR	400		14-						MCH 486 H1	MCH 901			
■ WR	400 F	CH04	98-00						MCH 427 V1				MCH 272 H1 MCH 901
WR	400 F	CH04	98-00		USA				MCH 230 V1	MCH 901			
■ XJR	400 R	4HM	95-97		++				MCH 476 V2	MCH 901			MCH 476 H1 MCH 901
■ XS	400 DOHC	12E	82-87						MCH 408 V2	MCH 901			
■ XS	400 S	4G5	80-83						MCH 156 V1	MCH 901			
■ XS	400 SE	2A2,4A3	77-82						MCH 462 V1	MCH 901			
■ WR	426	CJ	01-02						MCH 427 V1	MCH 901			MCH 855 H1 MCH 901
■ WR	426 F	CJ	01-02						MCH 427 V1	MCH 901			MCH 855 H1 MCH 901
■ WR	450		03-09						MCH 427 V1	MCH 901			MCH 855 H1 MCH 901
■ YFZ	450		04-07						MCH 864 V3	MCH 901			MCH 233 H1
YZ	450 F	CJ03,CJ05	05-07						MCH 191 V1	MCH 901			
■ RD	500 LC	47X,1GE	84-88						MCH 410 V5	MCH 951 MCH 901			MCH 438 H1 MCH 901
■ SR	500	48T	84-90						MCH 463 V1	MCH 901			
■ SR	500	2J4	78-79						MCH 479 V2	MCH 901			
■ SR	500	2J4	80-83		*				MCH 413 V3	MCH 951 MCH 901			
■ SR	500	2J4	80-83						MCH 415 V1	MCH 901			
■ SR	500	48T	84-90						MCH 414 V2	MCH 901			
■ XV	500	26R	83-89						MCH 358 V1	MCH 901			
■ XV	535 Virago	2YL,3BR	89-90						MCH 302 V1	MCH 901			
■ XV	535 SE,N,H	2YL,3BR	88-93						MCH 463 V1	MCH 901			
■ XV	535 Virago	2YL,3BR,4KU3	94-97						MCH 412 V1	MCH 901			
■ XV	535 Virago	2YL,3BR	98-02						MCH 412 V1	MCH 901			
■ XJ	550	4V8,4V9	81-83						MCH 420 V3	MCH 951 MCH 901			
■ XZ	550	11U, 11V	82-85						MCH 419 V3	MCH 951 MCH 901			
■ FZ	600		86-87						MCH 421 V3	MCH 901			MCH 425 H1 MCH 901
■ FZ6	600	RJ07	04-09		++				MCH 490 V2	MCH 901			MCH 490 H1 MCH 901
■ FZ6	600 Fazer	RJ07	04-09		++				MCH 490 V2	MCH 901			MCH 490 H1 MCH 901
FZ6	600 ABS	RJ14	07-										
■ FZ6	600 Fazer ABS	RJ07	06-07						MCH 499 V3	MCH 901			MCH 499 H2 MCH 901
■ FZR	600	3RG, 3RH	89						MCH 454 V3	MCH 951 MCH 901			MCH 454 H1 MCH 901
■ FZR	600 H,M,N	3HE, 3RG	90-93						MCH 454 V3	MCH 951 MCH 901			MCH 454 H1 MCH 901
■ FZR	600 R	4JH, 4MH	94-95		++				MCH 469 V2	MCH 901			MCH 462 H1 MCH 901
■ FZS	600 Fazer	RJ02	98-03						MCH 422 V3	MCH 951 MCH 901			MCH 422 H1 MCH 901
■ FZS	600 Fazer SP	RJ02	00-03						MCH 422 V3	MCH 951 MCH 901			MCH 422 H1 MCH 901
■ SRX	600 H,N	1XL,1XM	86-90						MCH 426 V3	MCH 951 MCH 901			MCH 426 H1 MCH 901



++/+ inkl. aller Schrauben – incl. bolts
 ++ inkl. Doppelhohlschraube – incl. doublebolt
 * Umbau auf Doppelbremse – double disc

Edelstahl poliert – stainless steel polished
 ohne Verteiler – without distributor
 Doppelzündung – Twin Spark

Flachlenker – Flatbar
 Hochlenker – Highbar
 BASIC Ohne Leitungen unter dem Tank – Without hoses under fuel tank



Yamaha

■ TT	600	59X	87-93		MCH 411 V1		MCH 901			
■ XJ	600	51J, 51H,3KN	84-91		MCH 421 V3	MCH 951	MCH 901		MCH 202 H1	MCH 901
■ XJ	600 Diversion	4BR	92-97		MCH 457 V1		MCH 901		MCH 423 H1	MCH 901
■ XJ	600 Diversion	RJ01	98-99		MCH 478 V2	MCH 951	MCH 901		MCH 423 H1	MCH 901
■ XJ	600 Diversion	RJ01	00-03		MCH 483 V2	MCH 951	MCH 901		MCH 423 H1	
■ XJ	600 N	4LX,4MB	94-97		MCH 355 V1		MCH 901		MCH 423 H1	MCH 901
■ XJ6	600 N,S	RJ19	09-11		MCH 873 V2	MCH 951	MCH 901		MCH 873 H1	MCH 901
■ XJ6	600 N,S ABS	RJ19	09-12		MCH 872 V3				MCH 872 H1	MCH 901
■ XT	600 E	3TB,3UW,DJ02	90-02		MCH 301 V1		MCH 901		MCH 116 H1	MCH 901
■ XT	600 H,N	2KF	87-89		MCH 423 V1		MCH 901		MCH 423 H1	MCH 901
■ XT	600 K	3TB,3UW	91-		MCH 301 V1		MCH 901		MCH 116 H1	MCH 901
■ XT	600 Z	55W,1VJ	85-89		MCH 424 V1		MCH 901			
■ XT	600 Z, Tenere	3AJ	90		MCH 301 V1		MCH 901		MCH 116 H1	MCH 901
■ YZF	600 R6	RJ03	99-02		MCH 480 V2	MCH 951	MCH 901		MCH 352 H1	MCH 901
■ YZF	600 R6	RJ05	03-04		MCH 488 V2	MCH 951	MCH 901		MCH 488 H1	MCH 901
■ YZF	600 R6	RJ09	05	++	MCH 489 V2		MCH 901		MCH 488 H1	MCH 901
■ YZF	600 R6	RJ11,RJ15	06-14	++	MCH 493 V2		MCH 901		MCH 493 H1	MCH 901
■ YZF	600 R6S	RJ09	06-07		MCH 488 V2	MCH 951	MCH 901			
■ YZF	600 Thunder Cat	4TV	96-02	++	MCH 475 V2		MCH 901		MCH 462 H1	MCH 901
■ XJ	650	4KO	80-85		MCH 428 V3		MCH 901			
■ XJ	650 Turbo	11T	82-85		MCH 464 V3		MCH 901			
■ XS	650	447	77-81		MCH 429 V3					
■ XS	650 SE	3L1, 4G7	80-81		MCH 215 V1		MCH 901		MCH 142 H1	MCH 901
■ XVS	650 Drag Star	4VR/XR	97-00		MCH 412 V1		MCH 901			
■ XVS	650 Drag Star	VM03	01-02				MCH 901			
■ XVS	650 A Drag Star Classic	VM02	98-01		MCH 170 V1		MCH 901			
■ XVS	650 A Drag Star Classic	VM03,VM04	02-06		MCH 215 V1		MCH 901			
■ MT-03	660	RM02	06-09	++	MCH 494 V2		MCH 901		MCH 494 H1	MCH 901
■ SZR	660	4SU	96-97		MCH 432 V1				MCH 432 H1	MCH 901
■ XT	660 R	DM01	04-11		MCH 191 V1		MCH 901		MCH 418 H1	MCH 901
■ XT	660 X	DM01	04-06		MCH 191 V1		MCH 901		MCH 418 H1	MCH 901
■ XT	660 X	DM01	07-11		MCH 191 V1		MCH 901		MCH 419 H1	MCH 901
■ XT	660 Z, Tenere	DM02	08-		MCH 886 V3				MCH 886 H1	
■ XTZ	660 Tenere	4MY3	91-96		MCH 465 V1		MCH 901		MCH 606 H1	MCH 901
■ YFM	660 Raptor	AM01	01-04				MCH 901			MCH 901
■ YFM	700 Raptor	AM07	05-				MCH 901			
■ FZ	750	2KK	87-88		MCH 435 V3		MCH 901		MCH 435 H1	MCH 901
■ FZ	750	1FN,1TV	85-88		MCH 436 V3		MCH 901		MCH 435 H1	MCH 901
■ FZ	750	2KK, 3KT	89-96		MCH 452 V3		MCH 901		MCH 435 H1	MCH 901
■ FZR	750 R OW01	3PJ	89-93	++	MCH 453 V2		MCH 921		MCH 434 H1	
■ FZR	750 R,RT	3CU,2TT	87-88		MCH 444 V3		MCH 901		MCH 459 H1	MCH 901
■ FZX	750 Fazer	2JE	87-89		MCH 434 V3				MCH 434 H1	
■ XJ	750	41Y	84-86		MCH 437 V5					
■ XJ	750 Seca	11M	82-83		MCH 437 V4					
■ XS	750	1T5	78-80		MCH 438 V3		MCH 901		MCH 359 H1	MCH 901
■ XS	750 SE		78-81		MCH 447 V3	MCH 951	MCH 901		MCH 359 H1	MCH 901
■ XTZ	750 H,N	3LD/3WV	89-96		MCH 433 V3	MCH 951	MCH 901		MCH 433 H1	MCH 901
■ XV	750	4FY	92-93		MCH 447 V3	MCH 951	MCH 901			
■ XV	750 SE	5G5, 5K4	81-84		MCH 431 V1		MCH 901			
■ XV	750 Virago	4PW	94-97		MCH 441 V3	MCH 951	MCH 901			
■ YZF	750 R,SP	4HN,4HT	93-98	++	MCH 467 V2		MCH 901		MCH 233 H1	MCH 901
■ FZ8	800 Fazer ABS	RN25	11-		MCH 881 V3		MCH 901		MCH 881 H2	MCH 901
■ TDM	850	4TX	96-01	++	MCH 474 V2		MCH 901		MCH 462 H1	MCH 901
■ TDM	850 H,N	3VD, 4CM	91-94		MCH 466 V3	MCH 951	MCH 901		MCH 462 H1	MCH 901
■ TDM	850 H,N	3VD, 4CM	95		MCH 158 V3	MCH 951	MCH 901		MCH 462 H1	MCH 901
■ TRX	850	4UN	96-98	++	MCH 473 V2		MCH 901		MCH 233 H1	MCH 901
■ XS	850	4H1	80-82		MCH 438 V3		MCH 901		MCH 359 H1	MCH 901
■ MT-09	900 ABS									
■ TDM	900	RN08, RN11	02-05	++	MCH 486 V2		MCH 901		MCH 486 H1	MCH 901
■ TDM	900 ABS	RN14,RN18	05-10		MCH 870 V6		MCH 901		MCH 870 H2	MCH 901
■ XJ	900 F	31A,42N	83-84		MCH 440 V5		MCH 901		MCH 450 H1	MCH 901
■ XJ	900 F	58L	85-86		MCH 428 V3		MCH 901		MCH 450 H1	MCH 901
■ XJ	900 F	58L,3NG1,4BB	87-94		MCH 428 V3		MCH 901		MCH 450 H1	MCH 901
■ XJ	900 S, Diversion	4KM	97-02	++	MCH 472 V2		MCH 901		MCH 472 H1	MCH 901
■ XJ	900 S, Diversion	4KM	95-96				MCH 901		MCH 472 H1	MCH 901
■ XVS	950 A, Midnight Star	VN021	09-12		MCH 431 V1		MCH 901		MCH 431 H1	MCH 901



Yamaha

■ FZ1	1000	RN16	06-13	++	MCH 495 V2		MCH 901		MCH 495 H1	MCH 901
■ FZ1	1000 Fazer	RN16	06-11	++	MCH 495 V2		MCH 901		MCH 495 H1	MCH 901
■ FZ1	1000 ABS	RN16	08-12		MCH 498 V5		MCH 901		MCH 498 H2	MCH 901
■ FZ1	1000 Fazer ABS	RN16	07-11		MCH 857 V5		MCH 901		MCH 498 H2	MCH 901
■ FZR	1000	2LA	87-88		MCH 444 V3	MCH 951	MCH 901		MCH 444 H1	MCH 901
■ FZR	1000	3LE	91-93		MCH 456 V3		MCH 901		MCH 443 H1	MCH 901
■ FZR	1000	3LE	94-95	++	MCH 470 V2		MCH 901		MCH 444 H1	MCH 901
■ FZR	1000 R, Exup	3LE	89-90	++	MCH 443 V2		MCH 901		MCH 443 H1	MCH 901
■ FZS	1000 Fazer	RN06,RN14	01-05		MCH 484 V3	MCH 951	MCH 901		MCH 484 H1	MCH 901
■ GTS	1000	4BH			MCH 446 V2		MCH 901		MCH 352 H1	MCH 901
■ GTS	1000 ABS	4BH					MCH 901			
■ XV	1000 SE	23W	83-85		MCH 447 V3		MCH 901			
■ XV	1000 TR1	5A8, 19T	81-83		MCH 445 V3		MCH 901			
■ XV	1000 Virago	2AE	86-		MCH 447 V3		MCH 901			
■ YZF	1000 R1	RN01	98-99	++	MCH 477 V2		MCH 901		MCH 477 H1	MCH 901
■ YZF	1000 R1	RN04	00-01	++	MCH 477 V2		MCH 901		MCH 477 H1	MCH 901
■ YZF	1000 R1	RN09	02-03	++	MCH 477 V2		MCH 901		MCH 352 H1	MCH 901
■ YZF	1000 R1	RN12	04-06	++	MCH 489 V2		MCH 901		MCH 489 H1	MCH 901
■ YZF	1000 R1	RN19	07-08	++	MCH 496 V2		MCH 901		MCH 496 H1	MCH 901
■ YZF	1000 R1	RN22	09-14	++	MCH 860 V2		MCH 901		MCH 860 H1	MCH 901
■ YZF	1000 Thunder Ace	4VD	96-02	++	MCH 470 V2		MCH 901		MCH 470 H1	MCH 901
■ BT	1100 Bulldog	RP05	02-06		MCH 485 V3	MCH 951	MCH 901		MCH 485 H1	MCH 901
■ FJ	1100	47E	84-85	Anti Dive	MCH 448 V5		MCH 901		MCH 448 H1	MCH 901
■ XS	1100	5K7,2H9	79-83		MCH 128 V3		MCH 901		MCH 145 H1	MCH 901
■ XV	1100 Virago	3LP	91-93		MCH 447 V3	MCH 951	MCH 901			
■ XV	1100 Virago	3LP	94-98		MCH 441 V3	MCH 951	MCH 901			
■ XVS	1100 Drag Star	VP05	99-01	++	MCH 481 V2		MCH 901		MCH 481 H1	MCH 901
■ XVS	1100 Drag Star Classic	VP16	00-06		MCH 416 V3		MCH 901		MCH 481 H1	MCH 901
■ FJ	1200	1XJ	86-87	Anti Dive	MCH 450 V5		MCH 901		MCH 448 H1	MCH 901
■ FJ	1200	3CW, 3YA	88-96		MCH 449 V3		MCH 901		MCH 450 H1	MCH 901
■ FJ	1200 ABS	3YA	91-		MCH 439 V6		MCH 901		MCH 439 H2	MCH 901
■ VMX	1200 V Max	1FK/1JH/2EN	85-92		MCH 451 V3	MCH 951	MCH 901		MCH 155 H1	MCH 901
■ VMX	1200 V Max	2WE/2WF/2LT/2EN	93-02		MCH 468 V3	MCH 951	MCH 901		MCH 155 H1	MCH 901
■ XJR	1200	4PU	95-98	++	MCH 471 V2		MCH 901		MCH 113 H1	MCH 901
■ XT	1200 Z Super Tenere	DP01	10-		MCH 890 V5				MCH 890 H2	
■ XVZ	1200 T	47G	84-88						MCH 340 H1	MCH 901
■ FJR	1300	RP04	01-02	++	MCH 471 V2		MCH 901		MCH 471 H1	MCH 901
■ FJR	1300 ABS	RP08	03		MCH 879 V4		MCH 901		MCH 491 H2	MCH 901
■ FJR	1300 ABS	RP11	04-06		MCH 491 V6		MCH 901		MCH 491 H2	MCH 901
■ FJR	1300 ABS	RP13	06-07		MCH 871 V5		MCH 901		MCH 409 H2	MCH 901
■ FJR	1300 ABS	RP13	08-11		MCH 871 V5		MCH 901		MCH 871 H2	MCH 901
■ XJR	1300	RP02	99-01		MCH 460 V3	MCH 951	MCH 901		MCH 113 H1	MCH 901
■ XJR	1300	RP06,RP10	02-07		MCH 487 V2	MCH 951	MCH 901		MCH 487 H1	MCH 901
■ XJR	1300	RP19	07-13		MCH 487 V2	MCH 951	MCH 901		MCH 487 H1	MCH 901
■ XVZ	1300 A, Royal Star	4YP	96-02		MCH 416 V3		MCH 901		MCH 416 H1	MCH 901
■ XVS	1300 A, Midnight Star	VP26	07-10		MCH 862 V2		MCH 901		MCH 862 H1	MCH 901
■ XV	1600 Wild Star	VP08	99-04		MCH 416 V3		MCH 901		MCH 420 H1	MCH 901
■ MT 01	1670	RP12, RP18	05-09	++	MCH 492 V2		MCH 901		MCH 492 H1	MCH 901
■ XV	1670 Road Star Warrior	VP14	03-05		MCH 887 V3					
■	1700 V-Max	RP21	09-		MCH 884 V3				MCH 884 H2	
■ XV	1900 Midnight Star	VP23	06-09	++	MCH 497 V2		MCH 901		MCH 497 H1	MCH 901

Zündapp

■ KS	50				MCH 200 V1					
■ KS	175		78-		MCH 701 V1		MCH 911			



++/+ inkl. aller Schrauben – incl. bolts
 ++ inkl. Doppelhohlschraube – incl. doublebolt
 * Umbau auf Doppelbremse – double disc

☐ Edelstahl poliert – stainless steel polished
 ✳ ohne Verteiler – without distributor
 2⚡ Doppelzündung – Twin Spark

~ Flachlenker – Flatbar
 ~ Hochlenker – Highbar
 BASIC Ohne Leitungen – Without hoses
 unter dem Tank – under fuel tank



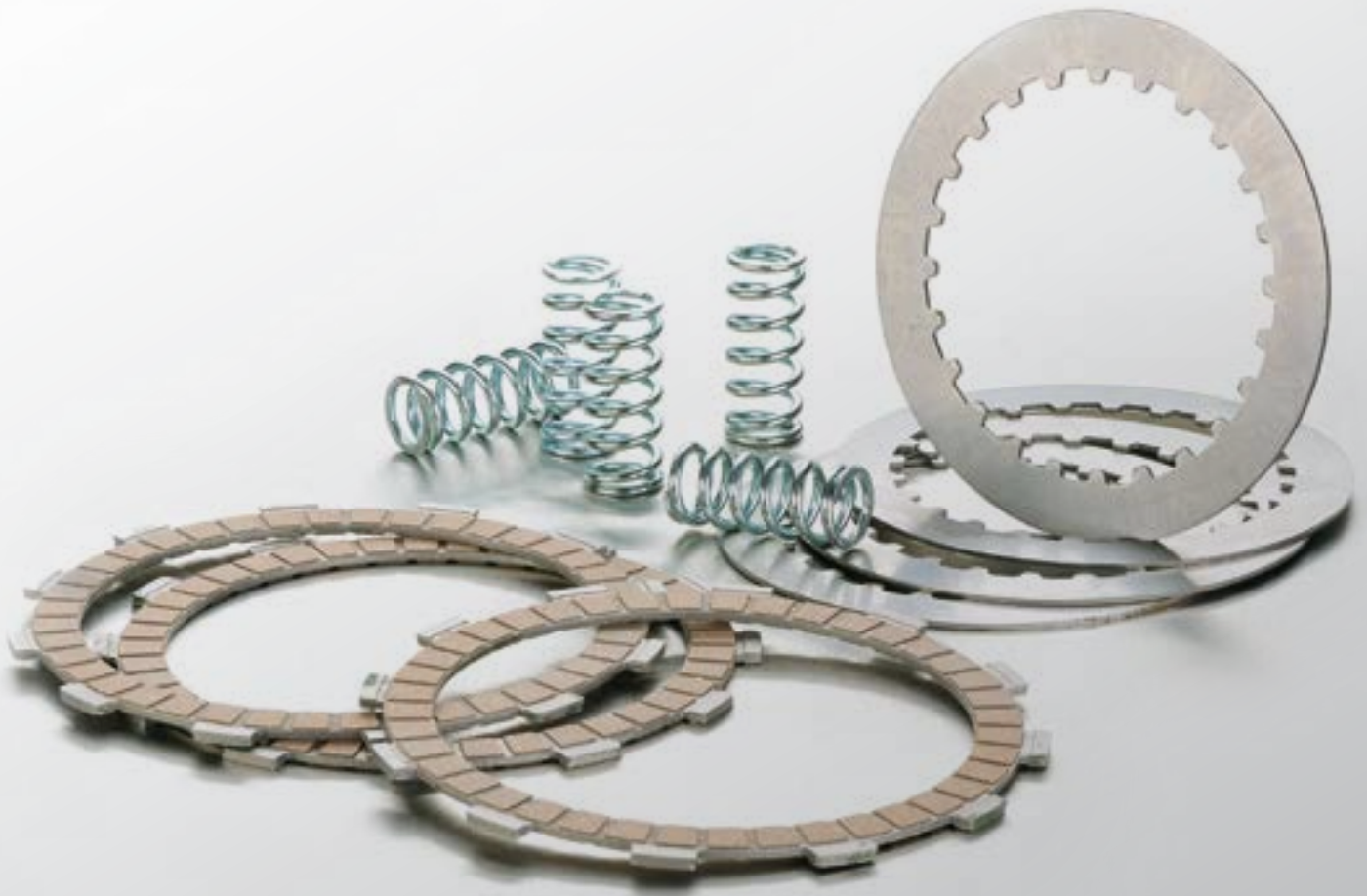

KUPPLUNGEN

EMBAYAGES

CLUTCHES

KUPPLUNGEN

CLUTCHES EMBRAYAGES



KUPPLUNGSLAMELLENSÄTZE

GARNITURES DE DISQUE D'EMBRAYAGE

CLUTCH FRICTION PLATE KIT

- » passgenaue Reibscheiben mit organischem Belagmaterial
 - » unterschiedliche Belagmischungen, orientiert an den Vorgaben des Originalteils
 - » verbesserte Kraftübertragung durch optimierte Abmessungen
 - » Lieferung aller benötigten Reiblamellen komplett als Satz
- » *precision friction discs with organic lining material*
 - » *different lining mixtures orientated towards the original part specification*
 - » *improved transfer of forces through optimised dimensions*
 - » *all required friction plates supplied as a complete set*
- » *disques de frottement ajustés fabriqués dans un matériau organique pour plaquettes*
 - » *différents alliages pour plaquettes, adaptés aux propriétés des pièces d'origine*
 - » *transmission améliorée des forces grâce à des dimensions optimisées*
 - » *fourniture de toutes les lamelles de frottement nécessaires sous forme de kits complets*

ACHTUNG! ATTENTION! ATTENTION!

Einige Synthetiköle begünstigen Kupplungsrutschen. Kupplungslamellen stets vorsichtig einfahren, um Verglasungen zu vermeiden.

Some synthetic oils encourage clutch slipping. Always run in clutch plates carefully to avoid glazing.

Certaines huiles synthétiques favorisent le patinage. Toujours roder les lamelles d'embrayage avec prudence afin d'éviter toute vitrification.

TIPP! TIP! CONSEIL!

Kupplungslamellen vor dem Einbau einige Zeit in Motoröl einlegen!

Soak clutch plates in engine oil for a while before fitting!

Tremper quelque temps les garnitures d'embrayage dans de l'huile moteur avant de les monter!

KUPPLUNGSLAMELLENSÄTZE FÜR HARLEY-DAVIDSON

SET DES DISQUES D'EMBRAYAGE POUR HARLEY-DAVIDSON

CLUTCH FRICTION PLATE KIT FOR HARLEY-DAVIDSON

- » Kupplungslamellen und Stahlzwischen Scheiben für viele Harley Davidson-Modelle
 - » große Marktabdeckung
 - » Design und Belagmischungen orientiert an den Vorgaben des OE-Teils
- » *clutch friction plates and clutch steel plates for many Harley Davidson models*
 - » *large market coverage*
 - » *design and pad composition based on the specifications of the OE part*
- » *lamelles d'embrayage et disques en acier pour de nombreux modèles Harley Davidson*
 - » *couverture importante du marché*
 - » *design et mélanges de revêtement orientés sur les indications de la pièce d'origine*



COMPETITION KIT



- » intelligenter Materialmix für höchste Standzeit bei besten Reibeigenschaften
 - » hohe Festigkeit durch Carbonanteil im Belagmaterial
 - » stabiler Druckpunkt und ausgezeichnete Dosierbarkeit
 - » verlustarme Übertragung höchster Anfahr-Drehmomente
 - » geringer Abrieb für lange Lebensdauer
 - » hervorragende Hitzestabilität
- » *an intelligent mix of materials for maximum durability with the best friction properties*
 - » *high strength thanks to lining material containing carbon*
 - » *stable pressure point and excellent controllability*
 - » *low-loss transfer of even the highest start-up torques*
 - » *low abrasion for a long service life*
 - » *excellent thermal stability*
- » *mélange intelligent de matériaux pour une durabilité extrême et une résistance au frottement idéale*
 - » *résistance élevée grâce à la présence de carbone dans le matériau des plaquettes*
 - » *point de poussée stable et dosage exceptionnel*
 - » *transmission des couples de rotation les plus élevés rencontrés au démarrage sans pertes importantes*
 - » *frottement réduit pour des durées de vie prolongées*
 - » *résistance exceptionnelle à la chaleur*

RACING

NEU! NEW! NOUVEAU!

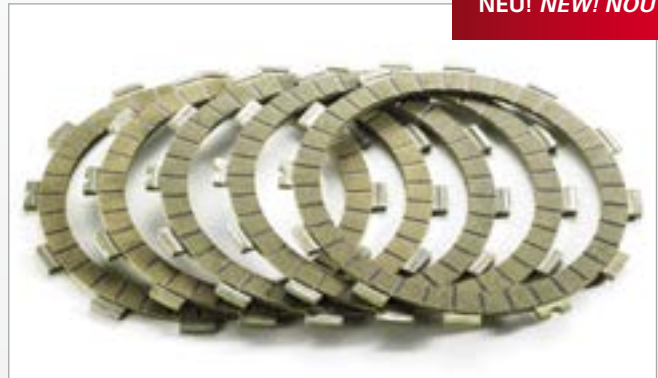

- » **das ultimative Kupplungs-Reibmaterial für schnelle Straßen, Sport- und Rennfahrer**
 - » ideal für alle High-Performance Anwendungen
 - » noch bessere Hitzebeständigkeit und längere Lebensdauer
 - » perfekte Mischung ausgesuchter Rohmaterialien mit hohem Carbonanteil
 - » sehr geringe Kompressibilität, dadurch kein Schlupf oder Kuppelungsrupfen auch bei höchsten Drehzahlen und Drehmomenten
- » **the ultimate clutch friction material for fast road, sports riders and racers**
 - » *ideal for all high performance applications*
 - » *improved heat resistance and longer service life*
 - » *perfect combination of selected raw materials with high carbon content*
 - » *very low compressibility, therefore no slipping or sticking even at the highest speeds and torques*
- » **le matériau de frottement d'embrayage ultime pour les pilotes rapides sur route et sur circuits**
 - » *idéal pour toutes les applications haute performance*
 - » *meilleure résistance à la chaleur et plus longue durée de vie*
 - » *Mélange parfait de matières premières sélectionnées avec une teneur en carbone élevée*
 - » *Compressibilité très basse, de ce fait pas de glissement d'embrayage même à des vitesses ou à des couples plus élevés.*

TROCKENKUPPLUNGEN FÜR BMW

EMBAYAGES SECS POUR BMW

DRY CLUTCHES FOR BMW



- » sehr lange Haltbarkeit
 - » konstante Leistung auch bei hohen Temperaturen
 - » zuverlässige Kraftübertragung auch bei extremen Einsätzen
- » *withstands high loads and temperatures*
 - » *constant performance over a long period*
 - » *high endurance also in extreme use*
- » *performances constantes sur une plus longue période de temps*
 - » *supporte de très hautes températures et une charge accrue*
 - » *résistant à un usage sportif ou extrême*

POWER KIT

POWER KIT
POWER KIT



» **Kupplungslamellen und Stahlzwischen Scheiben komplett als verstärktes Set**

- » hohe Verschleißresistenz
- » Top-Performance auch bei höchsten Temperaturen
- » verlustfreie Übertragung der Leistung auch bei extremen Einsätzen

» **clutch discs and intermediate steel plates complete as a reinforced set**

- » high wear resistance
- » top performance even at the highest temperatures
- » loss-free transmission of power even during extreme use

» **lamelles d'embrayage et disques intermédiaires en acier, fournis complets, sous forme de kit**

- » résistance élevée à l'usure
- » performances de pointe, même à des températures extrêmes
- » transmission intégrale de la puissance, même pour des utilisations extrêmes

KUPPLUNGS-SUPERKIT

LE SUPER KIT D'EMBAYAGE
CLUTCH SUPER KIT

» **All-Inclusive-Kupplungs-Superkit inkl. Reibscheiben, Stahlzwischen Scheiben, Kupplungsfedern und, falls nötig, Kupplungsdeckeldichtung**

- » einfache und schnelle Bestellung
- » Preisvorteil
- » perfekt aufeinander abgestimmte Komplettlösungen

» **all inclusive clutch Superkit including friction discs, steel clutch plates, clutch springs and, if required, clutch cover gasket**

- » quick and easy ordering
- » price advantage
- » perfectly matched complete solutions

» **Kit d'embrayage, avec disques garnis, disques lisses en acier, ressorts d'embrayage et, au besoin, joint pour le couvercle**

- » commande facile et rapide
- » calcul simplifié et prix avantageux
- » Solutions complètes parfaitement assorties



NEU! NEW! NOUVEAU!

STAHLZWISCHENSCHLEIBENSÄTZE

SET DES DISQUES INTERMÉDIAIRES EN ACIER
CLUTCH PLATE KIT

HINWEIS! REMARK! REMARQUE!

Alte Zwischenscheiben auf Farbe und Beschaffenheit prüfen und am Besten mit wechseln.

Check colour and condition of the intermediate plates and preferably replace these at the same time.

Contrôler la couleur et la qualité des anciens disques intermédiaires; l'idéal est d'également les remplacer.



- » präzise Fertigung aus hochwertigem Stahl
- » geringer Abrieb für lange Lebensdauer
- » stabiler Druckpunkt, bessere Dosierbarkeit
- » Stärke und Abmessungen entsprechen dem Original

- » *precision manufacturing using high-quality steel*
- » *low abrasion for a long service life*
- » *stable pressure point, improved controllability*
- » *thickness and dimensions are the same as for the original*

- » *fabrication précise en acier de qualité*
- » *frottement réduit pour des durées de vie prolongées*
- » *point de poussée stable, dosage amélioré*
- » *épaisseurs et dimensions adaptées aux pièces d'origine*

KUPPLUNGSLEITUNGEN

CLUTCH HOSES FLEXIBLES D'EMBRAYAGE

- » Stahlflexleitungen für alle hydraulischen Kupplungssysteme
- » in Technologie und Design abgestimmt auf die TRW Stahlflex-Bremsleitungen
- » viele Leitungen fertig konfektioniert in original Längen verfügbar
- » Ausführung und Farbe entsprechen den Stahlflex-Bremsleitungen
- » auch Sonderlängen und farbige Ummantelungen möglich

- » *flexible steel lines for all hydraulic clutch systems*
- » *technology and design adapted to the TRW Steel Flex brake lines*
- » *many lines available ready-to-use in original lengths*
- » *design and colour correspond to the Steel Flex brake lines*
- » *custom lengths and coloured sheathings also available*

- » *durites en acier flex pour tous les systèmes d'embrayage hydrauliques*
- » *technologie et design adaptés aux durites de frein en acier flex TRW*
- » *nombreuses durites prêtes à l'emploi disponibles dans les longueurs d'origine*
- » *modèles et couleurs correspondant aux durites de frein en acier flex*
- » *longueurs spéciales et gaines de couleur également disponibles*



KUPPLUNGSFEDERNSÄTZE

SET DES RESSORTS D'EMBRAYAGE
CLUTCH SPRING KIT

ACHTUNG! CAUTION! ATTENTION!

Federn auf keinen Fall selbst kürzen!

On no account shorten the clutch springs!

Ne raccourcir en aucun cas soi-même les ressorts!



- » verstärkte Kupplungsfedernsätze
- » ca. 10% höherer Anpressdruck gegen über den Originalfedern
- » wirksamer Schutz vor Kupplungsrutschen

- » *reinforced clutch springs available as a complete set*
- » *approx. 10% higher contact pressure compared to original springs*
- » *effective protection against clutch slipping*

- » *ressorts d'embrayage renforcés, fournis complets, sous forme de kit*
- » *force de serrage env. 10% supérieure à celle des ressorts d'origine*
- » *protection efficace contre le patinage*



DIE POWER IM GRIFF

Kupplungskomponenten von TRW bringen dich zuverlässig voran – soweit du willst.

POWER MASTERED

TRW clutch components steadily drive you forward – as far as you want.

MAÎTRISEZ LA PUISSANCE

Les composants d'embrayage de TRW vous emmènent sans problème - aussi loin que vous voulez.





Aprilia

RSV	1000 Mille	ME	98-00	MCH 565 V1	MCH 911
RSV	1000 Mille, R Mille	RP	01-03	MCH 565 V1	MCH 911
SL	1000 Falco	PA	00-04		MCH 911

Cagiva

	750 Elefant		94-97	MCH 555 V1	MCH 911
	900 AC		93-96	MCH 555 V1	MCH 911
	900 I.E.		90-92	MCH 555 V1	MCH 911

Ducati

	400 SS	S	93-95	MCH 358 V1	MCH 911
	600 Pantah		82-	MCH 358 V1	MCH 911
	600 Monster	M	94-99	MCH 609 V1	MCH 911
	600 SS	S	94-98	MCH 358 V1	MCH 911
	748 Biposto	748	95-97	MCH 457 V1	MCH 911
	750 Monster	M	96-00	MCH 609 V1	MCH 911
	750 SS Supersport	S	91-97	MCH 358 V1	MCH 911
	800 Monster S2R	M4	05-07	MCH 508 V1	MCH 911
	851 Strada		90-92	MCH 431 V1	MCH 911
	888	S	93-94	MCH 431 V1	MCH 911
	900 Monster	M	93-97	MCH 607 V1	MCH 911
	900 Superlight		93-97	MCH 412 V1	MCH 911
	900 S2		83-	MCH 263 V1	MCH 911
	900 SS	S	90	MCH 153 V1	MCH 911
	900 SS	S	91-97	MCH 256 V1	MCH 911
	916 Biposto		94-97	MCH 457 V1	MCH 911
	916 ST 4	S2	99-	MCH 156 V1	MCH 911
	944 ST 2		97-00	MCH 156 V1	MCH 911
	1000 Mike Hailwood	MH	84-86	MCH 358 V1	MCH 911
	1098 S/R	H7	05-	MCH 415 V1	MCH 911
	1198 S/R	H7	07-11	MCH 415 V1	MCH 911

Honda

RVF	750 R	RC45	94-97	MCH 457 V1	MCH 901
VFR	750 F	RC24	86-87	MCH 215 V1	MCH 901
VFR	750 F	RC24	88-89	MCH 215 V1	MCH 901
VFR	750 F	RC36	90-97	MCH 215 V1	MCH 901
VFR	750 R	RC30	88-	MCH 463 V1	MCH 901
VT	750 C	RC29	87-		MCH 901
VFR	800 V-Tec	RC46	98-01	MCH 156 V1	MCH 901
VFR	800 ABS	RC46	02-	MCH 196 V1	MCH 901
CB	1000 R	SC60	08-10	MCH 866 K1	MCH 901
CB	1000 Super Four	SC30	92-95	MCH 227 V1	MCH 901
CBF	1000	ABS SC58	06-08	MCH 827 V1	MCH 901
CBR	1000 F	SC24	93-99	MCH 431 V1	MCH 901
CBR	1000 F	SC21	87-88	MCH 227 V1	MCH 901
CBR	1000 F	SC24	89	MCH 227 V1	MCH 901
CBR	1000 F	SC24	90-92	MCH 431 V1	MCH 901
CBR	1000 RR	SC57	04-07	MCH 256 V1	MCH 901
VF	1000 R	SC16	84-86	MCH 365 V1	MCH 901
VTR	1000 Firestorm	SC36	97-06	MCH 556 V1	MCH 901
VTR	1000 SP-1	SC45	00-01	MCH 556 V1	MCH 901
VTR	1000 SP-2	SC45	02-05	MCH 556 V1	MCH 901
CBR	1100 XX	SC35	97-00	MCH 168 V1	MCH 901
ST	1100 Pan European	SC26	90-98	MCH 556 V1	MCH 901
CB	1300 S	ABS SC54	05-08	MCH 575 V1	MCH 901
GL	1520 F6C Valkyrie	SC34B	97-02		MCH 901

Kawasaki

GPX	750 R	ZX750F	87-	MCH 550 V1	MCH 901
GPZ	750 R	ZX750G	85-	MCH 550 V1	MCH 901
ZX-7R	750 Ninja	ZX750N	96-02	MCH 431 V1	MCH 901
ZXR	750	ZX750H	89-90	MCH 156 V1	MCH 901
ZXR	750	ZX750J	91-95	MCH 263 V1	MCH 901
GPZ	900 R	ZX900A	84-89	MCH 550 V1	MCH 901



Auf Anfrage – on request



Kawasaki

GPZ	900 R	ZX900A	90-93	MCH 550 V1	MCH 901
ZL	900		85-	MCH 227 V1	MCH 901
ZX-9R	900 Ninja	ZX900B	94-97	MCH 152 V1	MCH 901
GPZ	1000 RX	ZXT00A	86-	MCH 215 V1	MCH 901
GTR	1000	ZGT00A	86-94	MCH 551 V1	MCH 901
KLX	1000	LV1000A	04-06	MCH 153 V1	MCH 901
ZX-10R	1000	ZXT00B	88-90	MCH 227 V1	MCH 901
GPZ	1100	ZXT10E	95-98	MCH 215 V1	MCH 901
ZR	1100 Zephyr	ZRT10A	92-93	MCH 365 V1	MCH 901
ZR	1100 Zephyr	ZRT10B	94-97	MCH 153 V1	MCH 901
ZRX	1100	ZRT10C	97-00	MCH 559 V1	MCH 901
ZZR	1100	ZXT10C	90-92	MCH 227 V1	MCH 901
ZZR	1100	ZXT10D,G	93-01	MCH 227 V1	MCH 901
ZZR	1200	ZXT20C	02-05	MCH 153 V1	MCH 901
ZRX	1200 R,S	ZRT20A	01-04	MCH 431 V1	MCH 901
GTR	1400	ZG1400A	08-09	☎	MCH 901
ZZR	1400	ZXT40A/C	06-07	☎	MCH 901
VN	1500	VNT50A	87-95	MCH 517 V1	MCH 901
VN	1500 Classic	VNT50D	96-01	MCH 554 V1	MCH 901
VN	1500 Classic Tourer	VNT50D	98-	☎	MCH 901
VN	1500 Drifter	VNT50J	99-02	MCH 570 V1	MCH 901
VN	1500 Mean Streak	VNT50P	02-03	MCH 570 V1	MCH 901
VN	1600 Classic	VNT60A	03-06	☎	MCH 901
VN	1600 Mean Streak	VNT60B	04-08	MCH 570 V1	MCH 901

MV Agusta

F4	750 S	F4	99-	MCH 501 V1	
F4	1000 R, S		04-	MCH 501 V1	

Suzuki

VS	600 Intruder	VN51B	95-97	MCH 269 V1	MCH 921
GSX	650 F	WVCJ	08-	☎	MCH 901, MCH 921
GSXR	750	GR75A	85-87	MCH 215 V1	MCH 921
GSXR	750	GR77B	88-89	MCH 215 V1	MCH 921
VS	750 Intruder GLF, GLP	VR51BD	86-91	MCH 269 V1	MCH 921
VS	800 GL	VS52B	92-00	MCH 269 V1	MCH 921
RF	900 R	GT73B	94-97	MCH 170 V1	MCH 921
DL	1000 V-Strom	WVBS	02-12	MCH 153 V1	MCH 901
GSXR	1000	WVCL	07-08	MCH 215 V1	MCH 901
SV	1000 N	WVBX	03-06	MCH 263 V1	MCH 901
SV	1000 S	WVBX	03-06	MCH 170 V1	MCH 901
TL	1000 R	AM321	98-99	MCH 170 V1	MCH 901
GSX	1100 F	GV72C	88-96	MCH 156 V1	MCH 921
GSXR	1100	GV74CD	86-88	MCH 215 V1	MCH 921
GSXR	1100	GV73C	89-90	MCH 431 V1	MCH 921
GSXR	1100	GV73C	91-92	MCH 168 V1	MCH 921
GSXR	1100 W	GU75C	93-97	MCH 153 V1	MCH 901, MCH 921
GSF	1200 Bandit	WVA9	01-05	MCH 562 V1	MCH 901, MCH 921
GSF	1200 S, Bandit	WVA9	01-05	MCH 562 V1	MCH 901, MCH 921
GSF	1200 S, Bandit	WVCB	06	MCH 578 V1	MCH 901, MCH 921
GSF	1200 Bandit	GV75A	96-00	MCH 552 V1	MCH 921
GSF	1200 S, Bandit	GV75A	96-00	MCH 552 V1	MCH 921
GSX	1200 FS	A3	99-00	MCH 561 V1	MCH 921
GSF	1250 Bandit	WVCH	07-09	MCH 576 V1	MCH 901, MCH 921
GSX	1250 F	WVCH	10-	MCH 579 V1	
GSX	1300 B-King	WVCR	08-09	MCH 577 V1	MCH 901
GSX	1300 R Hayabusa	WVA1	99-07	MCH 153 V1	MCH 901, MCH 921
GSX	1300 R Hayabusa	WVCK	08-12	MCH 153 V1	MCH 901, MCH 921
GSX	1400	WVBN	01-07	MCH 569 V1	MCH 901, MCH 921
VS	1400 Intruder	VX51L/LD	91-03	MCH 229 V1	MCH 921
VL	1500 Intruder	WVAL	98-01	MCH 558 V1	MCH 901
VL	1500 Intruder	WVAL	02-04	MCH 558 V1	MCH 901
VL	1500 C 1500 Intruder	WVAL	05-08	MCH 882 K1	



Triumph

750 Trident	T300C	91-96	MCH 215 V1	
900 Adenturer	T309	96-	MCH 552 V1	
900 Legent	T309RT	95-	MCH 365 V1	
900 Speed Triple	T300B	94-96	MCH 215 V1	
900 Sprint	T300A	93-96	MCH 215 V1	
900 Thunderbird	T309RT	95-96	MCH 365 V1	MCH 901
900 Tiger	T400	91-96	MCH 358 V1	
900 Trident	T300	91-96	MCH 215 V1	
900 Trophy	T300E	91-96	MCH 215 V1	
1200 Trophy	T300	91-96	MCH 215 V1	
1200 Trophy	T300E	97-01	MCH 664 H1	

Yamaha

FZ	750	1FN,1TV	85-86	MCH 215 V1	MCH 901
FZ	750	2KK, 3DY	85-91	MCH 215 V1	MCH 901
FZR	750 R	3CU,2TT	87-88	MCH 215 V1	MCH 901
FZX	750 Fazer	2JE	87-89	MCH 550 V1	MCH 901
YZF	750 R	4HN,4HT	93-94	MCH 215 V1	MCH 901
FZR	1000	2LA	87-88	MCH 215 V1	MCH 901
FZR	1000	3LE	89-93	MCH 215 V1	MCH 901
FZR	1000	3LE	94-95	MCH 358 V1	MCH 901
YZF	1000 Thunder Ace	4VD	96-01	MCH 358 V1	MCH 901
FJ	1100	47E	84-85	MCH 215 V1	MCH 901
FJ	1200	1XJ	86-87	MCH 215 V1	MCH 901
FJ	1200	3CW, 3YA	88-95	MCH 215 V1	MCH 901
VMX	1200 V-Max	1FK/1JH/2EN	85-00	MCH 553 V1	MCH 901
XJR	1200	4PU	95-98	MCH 153 V1	MCH 901, MCH951
XT	1200 Z, Super Tenere	DP01	10-	MCH 168 V1	MCH 901
FJR	1300	RP04,RP11	01-06	MCH 431 V1	MCH 901
FJR	1300	RP13	06-10	MCH 871 K1	MCH 901
XJR	1300	RP01, RP02	98-01	MCH 153V1	MCH 901
XJR	1300	RP06,RP10	02-06	MCH 153 V1	MCH 901
XJR	1300	RP19	07-11	MCH 153 V1	MCH 901
MT01	1670	RP12	05-09	MCH 492 K1	MCH 901
	1700 V-Max	RP21	09-	MCH 580 V1	
XV	1900	VP23	06-08	MCH 574 K1	MCH 901



Auf Anfrage – on request





Aprilia

	50 Classic	GI	95-01		MCC 550-4		MES 317-4
	50 Pegaso		92-94		MCC 550-4		MES 317-4
	50 Red Rose		88-94		MCC 550-4		MES 317-4
	50 Tuareg		87-90		MCC 550-4		
	50 Tuono		03-04		MCC 550-4		MES 317-4
AF1	50 Futura		89-92		MCC 550-4		MES 317-4
ETX	50		86-		MCC 550-4		
MX	50		03-05		MCC 550-4		MES 317-4
RS	50 Extrema	HP	90-99		MCC 550-4		MES 317-4
RS	50 Replica	PG, TS	00-05		MCC 550-4		MES 317-4
RS	50		06-11		MCC 550-4		MES 317-4
RX	50		91-05		MCC 550-4		MES 317-4
RX	50		06-11		MCC 550-4		
SX	50		06-10		MCC 550-4		
AF1	125		90-92		MCC 552-6		
MX	125	TZ	04-06		MCC 552-6		
	125 Classic		96-01		MCC 552-6		
RS	125 Extrema		90-95		MCC 552-6		
	125 Pegaso		91-95		MCC 552-6		
	125 Tuono		03-04		MCC 552-6		
RS	125 Replica	MP	96-02		MCC 552-6		
RS	125 Replica Extrema	SF	03-13		MCC 552-6		
	125 Red Rose		89-95		MCC 552-6	MEF 102-6	
RS	250		95-01		MCC 309-7	MEF 102-6	
	280 Climber		91-94		MCC 552-6		
	650 Moto 6.5	MH00	95-99		MCC 604-7	MEF 160-6	
	650 Pegaso	MX	93-04		MCC 604-7	MEF 160-6	
	650 Pegaso Factory	VD	07-10		MCC 456-7		MES 352-6
	650 Pegaso Strada	VD	05-09		MCC 456-7		MES 352-6
	650 Pegaso Trail	VD	05-09		MCC 456-7		MES 352-6
ETV	1000 CapoNord	PS	01-07		MCC 551-9	MEF 160-6	
RST	1000 Futura	PW	01-04		MCC 551-9	MEF 160-6	
SL	1000 Falco	PA	00-04		MCC 551-9	MEF 160-6	
RSV	1000 Mille	ME	98-01		MCC 551-9	MEF 160-6	
RSV	1000 Mille R	RP	02-03		MCC 551-9	MEF 160-6	
RSV	1000 Mille R	RR	04-08		MCC 551-9	MEF 160-6	
RSV	1000 Tuono	RP	02-06		MCC 551-9	MEF 160-6	
RSV	1000 Tuono R	RR	06-08		MCC 551-9	MEF 160-6	
RSV4	1000 Factory, R	RK	09-12		MCC 553-10		

Arctic Cat

	300		98-05		MCC 336-8		
	400		00-02		MCC 229-5	MEF 164-6	
	400 DVX		04-06		MCC 445-8		

Benelli

BX	125		90-		MCC 429-6		MES 317-6
----	-----	--	-----	--	-----------	--	-----------

Beta

RR	50		97-02		MCC 506-6		
RR	50		03-08		MCC 550-4		
RR	50 Rev 3 Minitrial		07-08		MCC 505-6		
	80 Rev 3 Minitrial		04-08		MCC 505-6		
RR	125		06-08		MCC 403-5		MES 317-4
RR	125 Luftgekühlt		06-		MCC 102-4		
	125 Alp		01-06		MCC 305-7		
	200 Alp 4-stroke		01-08		MCC 305-7		
RR	250		05-08		MCC 508-7		
RR	250		05-08	Competition	MCC 508-7C		
RR	270		05-		MCC 508-7		
RR	270		05-	Competition	MCC 508-7C		
	350 Alp 4.0		03-08		MCC 328-7		MES 337-6
RR	400		05-06		MCC 530-7		
RR	400		05-06	Competition	MCC 530-7C		



Adjuster-/Ausgleichs-Kit falls erforderlich – if necessary
 Superkit siehe Seite 4.04 – see page 4.04
 Superkit* ohne Dichtung – without gasket

C (Competition) Hightech Reibmaterial – hightech friction
 PK (Powerkit) Reiblamellen + Stahlscheiben – frictionplates + steelplates
 RAC (Racing) High-Performance Kupplung – high-performance clutch



Beta

RR	450		05-08		MCC 508-7		
RR	450		05-08	Competition	MCC 508-7C		
RR	525		05-08		MCC 508-7		
RR	525		05-08	Competition	MCC 508-7C		

Bimota

SB 8	996 Santamonica		05-06		MCC 349-10		MES 410-9
------	-----------------	--	-------	--	------------	--	-----------

BMW

R 45	450	248	81-		MCC 600		
R 45	450 N	248	81-		MCC 600		
R 50	500 /5		69-72		MCC 601		
R 60	600 /5		69-72		MCC 601		
R 60	600 /6		74-76		MCC 601		
R 60	600 /7		76-80		MCC 601		
F	650	169	7/94-00		MCC 604-7	MEF 160-6	
F	650 GS	R13	01-04		MCC 610-8	MEF 160-6	
F	650 GS	R13	05-07		MCC 612-7	MEF 160-6	
F	650 GS Dakar	R13	01-04		MCC 610-8	MEF 160-6	
F	650 GS Dakar	R13	05-07		MCC 612-7	MEF 160-6	
F	650 CS	K14	02-04		MCC 610-8	MEF 160-6	
F	650 CS, Scarver		05-07		MCC 612-7	MEF 160-6	
R 65	650	247	81-92		MCC 600		
R 65	650 GS	247	81-92		MCC 600		
R 65	650 RT	247	82-86		MCC 600		
K 75	750 C	75	85-88		MCC 603		
K 75	750 RT	75	85-94		MCC 603		
K 75	750 S	75	85-94		MCC 603		
R 75	750 /5		69-73		MCC 601		
R 75	750 /6	R75/6	73-76		MCC 601		
R 75	750 /7	R75/7	76-80		MCC 601		
R 80	800	247	80-		MCC 600		
R 80	800 GS	247E	80-94		MCC 600		
R 80	800 ST	247E	82-84		MCC 600		
R 80	800 /7	247	77-80		MCC 601		
R	850 GS	259	94-98		MCC 602		
R	850 R	259	94-98		MCC 602		
R	850 RT	259	94-98		MCC 602		
R 90	900 /6	R90/6	73-76		MCC 601		
R 90	900 S	R90/S	73-76		MCC 601		
HP4	1000 RR	K10	12-14		MCC 613-10		MES 374-9
HP4	1000 RR	K10	12-14	Adjuster-Kit			MES 903-2
K 1	1000	100	89-93		MCC 602		
K 100	1000 LT	100	83-93		MCC 602		
K 100	1000 RS	100	83-93		MCC 602		
K 100	1000 RT	100	83-93		MCC 602		
S	1000 R		14-		MCC 613-10		MES 374-9
S	1000 R		14-	Adjuster-Kit			MES 903-2
S	1000 RR		10-14		MCC 613-10		MES 374-9
S	1000 RR		10-14	Adjuster-Kit			MES 903-2
R 100	1000 CS	247	81-		MCC 600		
R 100	1000 GS	247	87-95		MCC 600		
R 100	1000 RS	247	81-84		MCC 600		
R 100	1000 RT	247	81-		MCC 600		
R 100	1000 /7	247	76-80		MCC 601		
R 100	1000 /T, RT		78-80		MCC 601		
R 100	1000 RS	247	76-80		MCC 601		
R 100	1000 S	247	76-80		MCC 601		
K 1100	1100 LT, RS	100	93-00		MCC 602		
R	1100 GS	259	93-99		MCC 602		
R	1100 R	259	95-00		MCC 602		
R	1100 RS	247	93-01		MCC 602		
R	1100 RT	259	93-00		MCC 602		
R	1100 S	R2S	98-05		MCC 608		
R	1150 GS	R21	99-03		MCC 608		
R	1150 R	R21	01-06		MCC 608		



BMW

R	1150 RS	R22	01-05		MCC 608		
R	1150 RT	R22	01-05		MCC 608		
K	1200 LT		97-09		MCC 607		
K	1200 R	K12R	04/06-		MCC 611-8		
K	1200 R	K12R	04/06-	Powerkit	MCC 611PK		
K	1200 S	K12S	04/06-		MCC 611-8		
K	1200 S	K12S	04/06-	Powerkit	MCC 611PK		
K	1200 RS	589	97-05		MCC 607		
K	1200 GT	K12	02-05		MCC 607		
K	1200 GT	K12S	06-		MCC 611-8		
K	1200 GT	K12S	06-	Powerkit	MCC 611PK		
R	1200 C	259C	98-		MCC 608		
R	1200 CL	K30	03-		MCC 608		
R	1200 GS, GS Adventure		04-12		MCC 609		
R	1200 nineT	R1ST	14-		MCC 609		
R	1200 R		07-10		MCC 609		
R	1200 R		11-14		MCC 609		
R	1200 RT		05-13		MCC 609		
R	1200 S		06-08		MCC 609		
R	1200 ST		05-07		MCC 609		
	1200 HP2 Enduro	RHP2	06-07		MCC 609		
	1200 HP2 Megamoto	RHP2	07-11		MCC 609		

Cagiva

W8	125		92-96		MCC 227-7		
WRE	125		94-00		MCC 504-7		
	125 Mito	8P	89-06		MCC 504-7		
	125 Roadster		94-01		MCC 227-7		
	125 Supercity	2F	91-94		MCC 227-7		
	125 Planet	N1	97-02		MCC 227-7		
	125 Raptor	N3	04-05		MCC 227-7		
	500 Canyon	3G	98-01		MCC 204-7		
W16	600	2G	93-00		MCC 204-7		
	600 River	3G	95-98		MCC 204-7		
	650 Raptor	M2	00-06		MCC 228-7		
	900 Elefant I.E		91-94		MCC 701PK		
	1000 Navigator	M5	00-05		MCC 344-9		
	1000 Raptor	M2	00-05		MCC 344-9		
	1000 Xtra-Raptor	M2	02-05		MCC 344-9		

CCM

	400 R35		07-		MCC 445-8		
	400 DS404		03-04		MCC 445-8		
	400 CR40		07		MCC 445-8		
SR40	400 Street Scrambler		07		MCC 445-8		
	650 DS644		04-		MCC 320-8	MEF 104-4	

CH

WSM	125		06-07		MCC 403-5		MES 317-4
WXE	125		06-07		MCC 403-5		MES 317-4

Derbi

	659 Mulhacen		06-08		MCC 416-8	MEF 114-6	
--	--------------	--	-------	--	-----------	-----------	--

Ducati

	400 Monster	M3	98-	Powerkit	MCC 700PK		
	600 Monster	M3	98-02	Powerkit	MCC 700PK		
	620 Monster (5Gang)	M4	02-04	Powerkit	MCC 700PK		
	620 Monster		05-06	Powerkit	MCC 703PK		
	620 Multistrada (5Gang)	A1	02-04	Powerkit	MCC 700PK		
	620 Multistrada		05-06	Powerkit	MCC 703PK		
	695 Monster		07-08	Powerkit	MCC 703PK		
	696 Monster		08-13	Powerkit	MCC 703PK		
	748 Biposto	748	95-03	Powerkit	MCC 701PK		



Adjuster-/Ausgleichs-Kit falls erforderlich – if necessary
 Superkit siehe Seite 4.04 – see page 4.04
 Superkit* ohne Dichtung – without gasket

C (Competition) Hightech Reibmaterial – hightech friction
 PK (Powerkit) Reiblamellen + Stahlscheiben – frictionplates + steelplates
 RAC (Racing) High-Performance Kupplung – high-performance clutch



Ducati

748 R	748S/H3	00-03	Powerkit	MCC 701PK		
748 S	748	97-03	Powerkit	MCC 701PK		
749 Dark, R, S	H5	04-07	Powerkit	MCC 701PK		
750 Monster	M	98-02	Powerkit	MCC 700PK		
750 SS	S	98-02	Powerkit	MCC 700PK		
800 Hypermotard 796		10-12	Powerkit	MCC 703PK		
800 Monster 796		11-13	Powerkit	MCC 703PK		
800 Monster		03-04	Powerkit	MCC 700PK		
800 Monster S2R		05-07	Powerkit	MCC 703PK		
800 SS	V5	02-06	Powerkit	MCC 700PK		
848		08-10		MCC 702-11		
848 EVO	H6	11-12		MCC 702-11		
848 Streetfighter		12-14		MCC 702-11		
899 Panigale		14-		MCC 702-11		
900 Monster	M	93-02	Powerkit	MCC 701PK		
900 SL		91-97	Powerkit	MCC 701PK		
900 SS		91-03	Powerkit	MCC 701PK		
916		94-98	Powerkit	MCC 701PK		
916 ST4	S2	99-02	Powerkit	MCC 701PK		
944 ST2		97-03	Powerkit	MCC 701PK		
992 ST3	S3	04-07	Powerkit	MCC 701PK		
996		99-01	Powerkit	MCC 701PK		
996 ST4S		01-05	Powerkit	MCC 701PK		
996 Monster S4R		03-07	Powerkit	MCC 701PK		
998 Matrix		04-05	Powerkit	MCC 701PK		
998 Monster S4R		06-07	Powerkit	MCC 701PK		
998 S		04-06	Powerkit	MCC 701PK		
999	H4	02-07	Powerkit	MCC 701PK		
1098		07-08	Powerkit	MCC 701PK		
1000 GT		05-07	Powerkit	MCC 701PK		
1000 GT		08-10		MCC 702-11		
1000 GT, Touring		09-		MCC 702-11		
1000 Monster		04-05	Powerkit	MCC 701PK		
1000 Monster S2R, S4R		06-08	Powerkit	MCC 701PK		
1000 Multistrada		02-07	Powerkit	MCC 701PK		
1100 Multistrada		07-09		MCC 702-11		
1000 SS	V5	02-04	Powerkit	MCC 701PK		
1000 Sport	C1	05-07	Powerkit	MCC 701PK		
1000 Sport	C1	08-09		MCC 702-11		
1100 Monster, Evo, Diesel	M5	11-13	Racingkit	MCC 704-11RAC		
1199 Panigale, R,S	H8	12-	Racingkit	MCC 704-11RAC		
1200 Diavel	G1	11-14	Racingkit	MCC 704-11RAC		
1200 Multistrada, S	A2	10-14	Racingkit	MCC 704-11RAC		

Garelli

50 Ukra		89-		MCC 200-5		
125 Tiger		85-88		MCC 112-6		
GTA	125	85-87		MCC 112-6		
TSR	125	83-85		MCC 112-6		

Gas Gas

EC	125	98-08		MCC 133-8	MEF 124-6	MES 326-7
MC	125	98-05		MCC 133-8		MES 326-7
MX	125	02-07		MCC 133-8		
SM	125	01-08		MCC 133-8	MEF 124-6	MES 326-7
EC	250 4 T	10-		MCC 455-9		
MC	250	96		MCC 217-8		
SM	450	03-06		MCC 133-8		MES 326-7

Gilera

500 Saturno		88-91		MCC 109-8		
RC	600	89-		MCC 109-8		
XRT	600	88-		MCC 109-8		

Harley-Davidson

XLH	883 Sportster		84-90	MCC 207-7		
VRSCA	1130 V-Rod	VR1	02-07	MCC 129-9		MES 335-9



Harley-Davidson

XLH	1100 Sportster	84-87		MCC 207-7	
FL	1200 Electra Glide	67-77		MCC 800-5	
FLH	1200 Electra Glide	67-77		MCC 800-5	
FX	1200 Super Glide	71-79		MCC 800-5	
FXE	1200 Super Glide	74-79		MCC 800-5	
XLH	1200 Sporster	84-90		MCC 207-7	
FXS	1200 Low Rider	77-79		MCC 800-5	
FLH	1340 Electra Glide	78-83		MCC 800-5	
FLH	1340 Electra Glide	84		MCC 801-6	
FLHR	1340 Electra Glide Road King	94-97	Competition	MCC 803-8C	MES 500-6
FLHRI	1340 Electra Glide Road King	96-97	Competition	MCC 803-8C	MES 500-6
FLHS	1340 Electra Glide	88-89		MCC 801-6	
FLHS	1340 Electra Glide Sport	90-93	Competition	MCC 803-8C	MES 500-6
FLHT	1340 Electra Glide Std.	96-97	Competition	MCC 803-8C	MES 500-6
FLHT	1340 Electra Glide Std.	98		MCC 802-9	MES 501-8
FLHTC	1340 Electra Glide Classic	81-83		MCC 800-5	
FLHTC	1340 Electra Glide Classic	84-89		MCC 801-6	
FLHTC	1340 Electra Glide Classic	90-97	Competition	MCC 803-8C	MES 500-6
FLHTC	1340 Electra Glide Classic	98		MCC 802-9	MES 501-8
FLHTCI	1340 Electra Glide Classic	96-97	Competition	MCC 803-8C	MES 500-6
FLHTU	1340 Electra Glide Ultra Classic	90-97	Competition	MCC 803-8C	MES 500-6
FLHTUI	1340 Electra Glide Ultra Classic	96-97	Competition	MCC 803-8C	MES 500-6
FLST	1340 Heritage Softail	87-89		MCC 801-6	
FLSTC	1340 Heritage Softail Classic	88-89		MCC 801-6	
FLSTC	1340 Heritage Softail Classic	90-97	Competition	MCC 803-8C	MES 500-6
FLSTC	1340 Heritage Softail Classic	98-99		MCC 802-9	MES 501-8
FLSTF	1340 Fat Boy	90-97	Competition	MCC 803-8C	MES 500-6
FLSTF	1340 Fat Boy	98-99		MCC 802-9	MES 501-8
FLSTN	1340 Heritage Softail Nostalg.	93-96	Competition	MCC 803-8C	MES 500-6
FLT	1340 Tour Glide	79-83		MCC 800-5	
FLT	1340 Tour Glide	84-89		MCC 801-6	
FLT	1340 Tour Glide	90-92	Competition	MCC 803-8C	MES 500-6
FLTC	1340 Tour Glide Classic	82-83		MCC 800-5	
FLTC	1340 Tour Glide Classic	84-85		MCC 801-6	
FLTC	1340 Tour Glide Classic	91		MCC 802-9	MES 501-8
FLTCU	1340 Ultra Classic Tour Glide	89		MCC 801-6	
FLTCU	1340 Ultra Classic Tour Glide	90-93	Competition	MCC 803-8C	MES 500-6
FXB	1340 Sturgis	80-82		MCC 800-5	
FXD	1340 Dyna Super Glide	95-97	Competition	MCC 803-8C	MES 500-6
FXD	1340 Dyna Super Glide	98		MCC 802-9	MES 501-8
FXDB	1340 Dyna Glide Sturgis	91-92	Competition	MCC 803-8C	MES 500-6
FXDL	1340 Dyna Glide Low Rider	93-97	Competition	MCC 803-8C	MES 500-6
FXDL	1340 Dyna Glide Low Rider	98		MCC 802-9	MES 501-8
FXDS	1340 Dyna GL.Low Rid.Conv.	94-97	Competition	MCC 803-8C	MES 500-6
FXDWG	1340 Dyna Wide Glide	93-97	Competition	MCC 803-8C	MES 500-6
FXDWG	1340 Dyna Wide Glide	98		MCC 802-9	MES 501-8
FXE	1340 Super Glide	79-83		MCC 800-5	
FXEF	1340 Fat Boy	85		MCC 801-6	
FXLR	1340 Low Rider Custom	87-89		MCC 801-6	
FXLR	1340 Low Rider Custom	90-94	Competition	MCC 803-8C	MES 500-6
FXR	1340 Super Glide II	82-83		MCC 800-5	
FXR	1340 Super Glide	86-89		MCC 801-6	
FXR	1340 Super Glide	90-94	Competition	MCC 803-8C	MES 500-6
FXRS	1340 Low Glide	84-89		MCC 801-6	
FXRS	1340 Low Rider	90-92	Competition	MCC 803-8C	MES 500-6
FXRS	1340 Low Rider Convertible	90-93	Competition	MCC 803-8C	MES 500-6
FXRS-SP	1340 Low Rider Sport Edition	86-89		MCC 801-6	
FXRS-SP	1340 Low Rider Sport Edition	90-93	Competition	MCC 803-8C	MES 500-6
FXRT	1340 Sport Glide	83		MCC 800-5	
FXRT	1340 Sport Glide	84-89		MCC 801-6	
FXRT	1340 Sport Glide	90-92	Competition	MCC 803-8C	MES 500-6
FXS	1340 Low Rider	77-83		MCC 800-5	
FXS	1340 Low Rider	84		MCC 801-6	



Adjuster-/Ausgleichs-Kit falls erforderlich – if necessary
 Superkit siehe Seite 4.04 – see page 4.04
 Superkit* ohne Dichtung – without gasket

C (Competition) Hightech Reibmaterial – hightech friction
 PK (Powerkit) Reiblamellen + Stahlscheiben – frictionplates + steelplates
 RAC (Racing) High-Performance Kupplung – high-performance clutch



Harley-Davidson

FXSB	1340 Low Rider	84-85		MCC 801-6	
FXSB	1340 Low Rider	82-83		MCC 800-5	
FXST	1340 Softail	84-89		MCC 801-6	
FXST	1340 Softail	90	Competition	MCC 803-8C	MES 500-6
FXSTB	1340 Night Train	98-99		MCC 802-9	MES 501-8
FXSTC	1340 Softail Custom	86-89		MCC 801-6	
FXSTC	1340 Softail Springer	88-89		MCC 801-6	
FXSTC	1340 Softail Springer	90-97	Competition	MCC 803-8C	MES 500-6
FXSTC	1340 Softail Custom	98-99		MCC 802-9	MES 501-8
FXSTS	1340 Softail Springer	90-97	Competition	MCC 803-8C	MES 500-6
FXSTS	1340 Softail Springer	98-99		MCC 802-9	MES 501-8
FXSTSB	1340 Bad Boy	95-97	Competition	MCC 803-8C	MES 500-6
FXWG	1340 Wide Glide	80-83		MCC 800-5	
FXWG	1340 Wide Glide	84-85		MCC 801-6	
FLHR	1450 Road King	98-06		MCC 802-9	MES 501-8
FLHRCI	1450 Road King Classic	99-05		MCC 802-9	MES 501-8
FLHRI	1450 Road King	05-06		MCC 802-9	MES 501-8
FLHRSI	1450 Road King Custom	04-06		MCC 802-9	MES 501-8
FLHT	1450 Electra Glide Std.	99-04		MCC 802-9	MES 501-8
FLHTC	1450 Electra Glide Classic	02-04		MCC 802-9	MES 501-8
FLHTCUI	1450 Ultra Classic Electra Glide	99-06		MCC 802-9	MES 501-8
FLHTI	1450 Electra Glide Std.	05-06		MCC 802-9	MES 501-8
FLSTB	1450 Night Train	01-06		MCC 802-9	MES 501-8
FLSTC	1450 Heritage Softail Classic	00-03		MCC 802-9	MES 501-8
FLSTCI	1450 Heritage Softail Classic	01-06		MCC 802-9	MES 501-8
FLSTDI	1450 Softail Deuce	05		MCC 802-9	MES 501-8
FLSTF	1450 Fat Boy	00-05		MCC 802-9	MES 501-8
FLSTS	1450 Heritage Springer	00-03		MCC 802-9	MES 501-8
FLSTSCI	1450 Softail Springer Classic	05-06		MCC 802-9	MES 501-8
FLTRI	1450 Road Glide	99-01		MCC 802-9	MES 501-8
FXD	1450 Dyna Super Glide	99-04		MCC 802-9	MES 501-8
FXDCI	1450 Dyna Super Glide Custom	04-05		MCC 802-9	MES 501-8
FXDL	1450 Dyna Low Rider	99-06		MCC 802-9	MES 501-8
FXDWG	1450 Dyna Wide Glide	99-06		MCC 802-9	MES 501-8
FXDX	1450 Dyna Super Glide Sport	99-05		MCC 802-9	MES 501-8
FXDXT	1450 Dyna Super Glide T-Sport	01-03		MCC 802-9	MES 501-8
FXST	1450 Softail Std.	00-04		MCC 802-9	MES 501-8
FXSTB	1450 Night Train	00-06		MCC 802-9	MES 501-8
FXSTD	1450 Softail Deuce	00-03		MCC 802-9	MES 501-8
FXSTDI	1450 Softail Deuce	01-04		MCC 802-9	MES 501-8
FXSTI	1450 Softail Std.	05-06		MCC 802-9	MES 501-8
FXSTS	1450 Softail Springer	00-04		MCC 802-9	MES 501-8
FLHR	1600 Road King	07-09		MCC 802-9	MES 501-8
FLHRC	1600 Road King Classic	07-11		MCC 802-9	MES 501-8
FLHRS	1600 Road King Classic	07-10		MCC 802-9	MES 501-8
FLHT	1600 Electra Glide Std.	07-10		MCC 802-9	MES 501-8
FLHTCU	1600 Ultra Classic Electra Glide	07-10		MCC 802-9	MES 501-8
FLHX	1600 Street Glide	07-09		MCC 802-9	MES 501-8
FLSTC	1600 Heritage Softail Classic	07-11		MCC 802-9	MES 501-8
FLSTF	1600 Fat Boy	06-11		MCC 802-9	MES 501-8
FLSTFB	1600 Fat Boy Special	10-11		MCC 802-9	MES 501-8
FLSTN	1600 Heritage Softail Deluxe	05-11		MCC 802-9	MES 501-8
FLSTSB	1600 Softail Cross Bones	08-11		MCC 802-9	MES 501-8
FLSTSC	1600 Softail Springer Classic	07		MCC 802-9	MES 501-8
FXCW	1600 Rocker	08-11		MCC 802-9	MES 501-8
FXDB	1600 Dyna Street Bob	07-11		MCC 802-9	MES 501-8
FXDC	1600 Dyna Super Glide Custom	07-11		MCC 802-9	MES 501-8
FXDF	1600 Dyna Fat Bob	08-11		MCC 802-9	MES 501-8
FXDL	1600 Dyna Low Rider	07-08		MCC 802-9	MES 501-8
FXDWG	1600 Dyna Wide Glide	07-11		MCC 802-9	MES 501-8
FXSTB	1600 Night Train	07-09		MCC 802-9	MES 501-8
FXSTBIC	1600 Night Creeper	07-09		MCC 802-9	MES 501-8
FXSTC	1600 Softail Custom	07-09		MCC 802-9	MES 501-8
FLSTFSE	1690 Fat Boy Screamin Eagle	05-06		MCC 802-9	MES 501-8
FLHTCU	1800 Ultra Classic Electra Glide	11-		MCC 802-9	MES 501-8
FLHX	1800 Street Glide	10-11		MCC 802-9	MES 501-8



Harley-Davidson

FLSTSE	1800 Softtail Convertible		10-11		MCC 802-9		MES 501-8
FXDSE	1800 Dyna Screaming Eagle		07-08		MCC 802-9		MES 501-8
FXSTSSE	1800 Softtail Springer S-Eagle		07-08		MCC 802-9		MES 501-8
FLSTSE	1800 Road Glide		11-		MCC 802-9		MES 501-8

HM

CRE	125		00-05		MCC 133-8		MES 326-7
CRE	125		90-99		MCC 504-7		
CRE	250		90-04		MCC 217-8		MES 332-8
CRE	450 F		03-05		MCC 155-8		
CRE	500		91-03		MCC 217-8		MES 332-8

Honda

CB	50 J	CB50J	77-81		MCC 100-3	MEF 103-4	
CRF	50		04-15		MCC 101-3		
CY	50	CY50	78		MCC 100-3	MEF 103-4	
MB	50 S	AC01	80-82		MCC 100-3	MEF 103-4	
MBX	50 SD	AC05	83-86		MCC 100-3	MEF 103-4	
MT	50 S	AD01	80-		MCC 100-3	MEF 103-4	
MTX	50 S	AD04	83-87		MCC 100-3	MEF 103-4	
NSR	50 S	AC08	89-00		MCC 100-3	MEF 103-4	MES 331-2
ST	50 Dax	ST50	78-93		MCC 101-3		
XR	50		01-03		MCC 101-3		
Z	50 A	Z50A	73-79		MCC 101-3		
Z	50 J	AE02	79-85		MCC 101-3		
Z	50 R	AB020	79-86		MCC 101-3		
CRF	70		04-13		MCC 101-3	MEF 118-6	
XR	70		97-03		MCC 101-3	MEF 118-6	
NSR	75		92-00		MCC 102-4	MEF 103-4	
CR	80 R		85-89		MCC 103-5	MEF 104-4	MES 331-4
CR	80 R	HE04	90-02		MCC 103-5	MEF 104-4	MES 331-4
CRF	80		04-12		MCC 100-3	MEF 161-4	MES 331-2
CY	80	CY80	79-		MCC 100-3		
MB	80 S	HC01	80-		MCC 102-4	MEF 103-4	
MBX	80 SW	HC04	83-		MCC 102-4	MEF 103-4	
MBX	80 SW2	HC04	87-		MCC 102-4	MEF 103-4	
MBX	80 SWD	HC04	83-85		MCC 102-4	MEF 103-4	
MBX	80 SWZ	HC04	83-85		MCC 102-4	MEF 103-4	
MCX	80 S	HC05	83-		MCC 102-4	MEF 103-4	
MT	80 S	HD02	80-		MCC 102-4	MEF 103-4	
MTX	80 C	HD06	82-		MCC 102-4	MEF 103-4	
MTX	80 R2	HD09	87-		MCC 102-4	MEF 103-4	
MTX	80 RS	HD08	83-84		MCC 102-4	MEF 103-4	
NSR	80		88-99		MCC 102-4	MEF 103-4	
XR	80		79-84		MCC 100-3		MES 331-2
XR	80	HE01	85-03		MCC 100-3		MES 331-2
CR	85 R		03-07		MCC 103-5	MEF 104-4	MES 331-4
TRX	90		93-15		MCC 102-4		MES 331-4
CRF	100		04-13		MCC 102-4	MEF 123-6	MES 331-4
NF	100 Astrea Supra		97-99		MCC 102-4		
XR	100		85-03		MCC 102-4	MEF 123-6	MES 331-4
ANF	125	JC33	03-11		MCC 163-4		MES 331-4
CA	125 Rebel	JC24	95-97		MCC 146-5	MEF 109-4	MES 331-4
CA	125 Rebel	JC26	98-00		MCC 146-5	MEF 109-4	MES 331-4
CB	125 J	CB125J	75-81		MCC 103-5	MEF 104-4	
CB	125 T,T2	CB125T	78-81		MCC 103-5	MEF 109-6	
CBF	125	JC40A	09-14		MCC 103-5		
CBR	125	JC34	04-06		MCC 159-5		MES 331-4
CBR	125	JC39	07-10		MCC 159-5		MES 371-4
CBR	125	JC50	11-14		MCC 159-5		MES 371-4
CG	125		01-08		MCC 159-5	MEF 141-6	MES 331-4
CLR	125 Cityfly	JD18B	98-99		MCC 103-5	MEF 109-4	MES 331-4
CM	125 C	JC05	82		MCC 103-5	MEF 109-6	MES 331-4



Adjuster-/Ausgleichs-Kit falls erforderlich – if necessary
 Superkit siehe Seite 4.04 – see page 4.04
 Superkit* ohne Dichtung – without gasket

C (Competition) Hightech Reibmaterial – hightech friction
 PK (Powerkit) Reiblamellen + Stahlscheiben – frictionplates + steelplates
 RAC (Racing) High-Performance Kupplung – high-performance clutch



Honda

CR	125 R	JE01	84-85	MCC 107-6	MEF 124-6	MES 326-5
CR	125 R	JE01	85-99	MCC 432-7	MEF 124-6	MES 326-6
CR	125 R		00-11	MCC 133-8	MEF 159-5	MES 326-7
MTX	125 RW		85-91	MCC 106-5	MEF 104-4	MES 326-4
NSR	125 R	JC22	88-03	MCC 114-6	MEF 106-6	MES 326-5
NX	125		89-97	MCC 159-5	MEF 141-6	MES 331-4
VT	125 C Shadow	JC29	99-08	MCC 150-5	MEF 133-5	MES 336-4
XL	125 R		85-91	MCC 103-5	MEF 109-6	MES 331-4
XLR	125	JD	98-99	MCC 103-5	MEF 109-4	MES 331-4
XLV	125 Varadero	JC32	01-11	MCC 150-5	MEF 133-5	MES 336-4
XR	125	JD19	03-08	MCC 103-5	MEF 141-6	MES 331-4
CRF	150		03-05	MCC 222-6	MEF 159-5	
CRF	150 R		06-07	MCC 134-6	MEF 106-6	
CRF	150 R	CRF150	08-15	MCC 134-6		
ATC	185		80-83	MCC 102-4		
CM	185 T	CM185T	78-82	MCC 103-5	MEF 109-6	MES 331-4
XL	185 S	L185S	79-81	MCC 103-5	MEF 124-6	MES 331-4
ATC	200		81-84	MCC 102-4	MEF 124-6	
CM	200 T	MC01	80-81	MCC 103-5	MEF 124-6	MES 331-4
MTX	200 RW	MD07	85-	MCC 104-5	MEF 104-4	MES 326-4
MTX	200 RW	MD07	83-84	MCC 108-6	MEF 104-4	MES 326-5
TRX	200 Fourtrax		90-97	MCC 103-5		MES 331-4
XL	200 R	MD06	83-89	MCC 103-5		MES 331-4
XR	200		80-02	MCC 103-5	MEF 124-4	MES 331-4
CRF	230 F		04-09	MCC 222-6	MEF 124-4	
CRF	230 L		08-10	MCC 146-5	MEF 109-4	
CRF	230 M		08-10	MCC 146-5	MEF 109-4	
CB	250 N	CB250N	79-82	MCC 105-7	MEF 116-4	
CB	250 T,T2	CB250T	78-	MCC 105-7	MEF 115-6	
CB	250 RS	MC02	80-84	MCC 106-5	MEF 109-6	
CB	250 G	CB250	74-76	MCC 109-8	MEF 104-4	
CB	250 N		92-97	MCC 134-6	MEF 124-6	
CB	250 Two Fifty		93-05	MCC 134-6	MEF 124-6	
CBF	250		04-06	MCC 107-6		MES 326-5
CBR	250 R	MC41	11-13	MCC 362-5		MES 367-4
CJ	250 T		77-78	MCC 109-8	MEF 124-6	
CM	250 C	MC06	82-	MCC 134-6	MEF 115-6	
CMX	250 Rebel	MC13B	96-02	MCC 134-6	MEF 124-4	
CR	250 R	ME03	81-82	MCC 432-7	MEF 104-4	
CR	250 R	ME03	83-89	MCC 116-7	MEF 115-6	MES 332-6
CR	250 R	ME03	90-93	MCC 138-8	MEF 128-6	MES 332-8
CR	250 R	ME03	94-96	MCC 138-8	MEF 132-6	MES 332-8
CR	250 R	ME03	97-99	MCC 138-8	MEF 132-6	MES 411-7
CR	250 R	ME03	00-01	MCC 138-8	MEF 132-6	MES 411-7
CR	250 R		02-07	MCC 138-8	MEF 132-6	MES 411-7
CRF	250 R	ME11	04-09	MCC 157-8	MEF 159-5	MES 326-7
CRF	250 R		10-15	MCC 157-8		MES 326-7
CRF	250 X		04-12	MCC 157-8		MES 326-7
NX	250	MD21	88-93	MCC 107-6	MEF 109-6	MES 326-5
TRX	250		02-14	MCC 103-5	MEF 109-6	MES 331-4
TRX	250 Fourtrax	TRX250	97-01	MCC 103-5		MES 371-4
XL	250 R	MD03	81-83	MCC 106-5	MEF 109-6	MES 336-4
XL	250 R	MD11	84-87	MCC 104-5	MEF 104-4	MES 326-4
XL	250 S	L250S	80	MCC 106-5	MEF 109-6	MES 326-4
XR	250 R	ME10	81-83	MCC 106-5	MEF 109-6	MES 336-4
XR	250 R	ME06	84-85	MCC 104-5	MEF 104-4	
XR	250 R		86-95	MCC 107-6	MEF 104-4	MES 326-5
XR	250 R		96-04	MCC 107-6	MEF 148-4	MES 326-5
CRF	300 X		08-12	MCC 157-8		MES 326-7
TRX	300 EX	TE19	93-09	MCC 107-6	MEF 104-4	
CB	350 F,F1	CB350F	73-76	MCC 105-7	MEF 115-6	
CB	350 K4		74	MCC 109-8	MEF 103-4	
TRX	350 TE, FE, Fourtrax		00-05	MCC 114-6	MEF 104-4	MES 310-5
XL	350 R	ND03	85-87	MCC 108-6		MES 326-5
CB	360 G	CB360	73-76	MCC 109-8	MEF 131-4	
CJ	360 T	CJ360T	76-78	MCC 109-8	MEF 131-4	



Honda

CB	400 F	CB400F	75-77		MCC 105-7	MEF 131-4	
CB	400 N	CB400N	79-82		MCC 105-7	MEF 147-4	MES 334-6
CB	400 Twin	CB400T	78-82		MCC 105-7	MEF 147-4	MES 326-6
CB	400 Four	CB400F	81-		MCC 112-7		
CB	400 F	CB400F	89-94		MCC 117-6		
CBR	400	NC23	88-89		MCC 117-6	MEF 106-6	MES 333-5
CBR	400	NC29	90-94		MCC 118-7	MEF 133-4	
CM	400 T	NC01	79-82		MCC 105-7	MEF 115-6	MES 326-6
NSR	400 R	NC19	85-89		MCC 110-8	MEF 109-6	MES 336-7
NV	400		92-02		MCC 114-6	MEF 128-6	MES 334-6
TRX	400 FW		00-02		MCC 112-6		MES 326-5
TRX	400 Fourtrax		99-04		MCC 145-7		MES 334-6
TRX	400 Sportrax		01-06		MCC 145-7		MES 334-6
VFR	400	NC21	85-86		MCC 113-9	MEF 106-6	
VFR	400	NC24	87-88		MCC 113-9	MEF 109-6	
VFR	400 R	NC30	90-92		MCC 143-10		
XR	400 R	NE03	97-05		MCC 145-7	MEF 133-5	MES 326-6
TRX	420 FM		07-11		MCC 112-7		
CB	450 N	PC14	85-		MCC 105-7	MEF 115-6	MES 326-6
CB	450 S	PC17	86-89		MCC 105-7	MEF 115-6	MES 334-6
CB	450 SC	PC17	85-		MCC 105-7	MEF 115-6	MES 326-6
CMX	450 Rebel	PC14	86-87		MCC 105-7	MEF 115-6	MES 326-6
CRF	450 R	PE05	02-10		MCC 155-8	MEF 132-6	MES 360-7
CRF	450 R		11-15		MCC 445-8		MES 360-7
CRF	450 X		05-15		MCC 155-8	MEF 132-6	MES 360-7
TRX	450 ES Foreman	TE22	98-02		MCC 112-6		MES 326-5
TRW	450 FM, FE Fourtrax Foreman	TE22	02-04		MCC 112-6		
TRX	450 R		04-08		MCC 162-8		MES 360-7
CB	500	PC26	94-03		MCC 118-7	MEF 133-4	MES 334-6
CB	500	PC26	94-04	Superkit	MSK 208		
CB	500	CB500	-74		MCC 123-7		
CB	500	CB500	74-77		MCC 135-5	MEF 104-4	
CBF	500	PC39	04-07		MCC 118-7	MEF 133-5	MES 334-6
CBF	500	PC39	04-08	Superkit	MSK 208		
CR	500 R	PE02	84-89		MCC 116-7	MEF 115-6	MES 332-6
CR	500 R	PE02	90-03		MCC 138-8	MEF 128-6	MES 332-8
CX	500	CX500	79-82		MCC 111-7	MEF 141-6	
CX	500 C	PC01	80-		MCC 111-7	MEF 141-6	
CX	500 E	PC06	82-		MCC 111-7	MEF 141-6	
FT	500 C	PC07	82-		MCC 112-7	MEF 115-6	MES 336-7
GL	500 D	PC02	81-82		MCC 111-7	MEF 141-6	
GL	500 D	PC02	83		MCC 136-7	MEF 109-6	
NX	500		88-99		MCC 116-7	MEF 116-4	MES 332-6
TRX	500 FE	TE31	10-11		MCC 112-7		
TRX	500 FE	TE38	12-		MCC 112-7		
TRX	500 Fourtrax		05-10		MCC 112-7		
VF	500 F	PC12	84-85		MCC 113-9	MEF 109-6	
VF	500 F2	PC12	84-85		MCC 113-9	MEF 109-6	
VT	500 C	PC08	83		MCC 114-6		MES 334-6
VT	500 E	PC11	83-85		MCC 114-6	MEF 115-6	MES 334-6
XBR	500 S	PC15	85-90		MCC 115-7	MEF 116-4	MES 332-6
XL	500 R	PD02	82-84		MCC 105-7	MEF 115-6	
XL	500 S	PD01	79-81		MCC 105-7	MEF 115-6	
XR	500 R	PE010	79-82		MCC 112-7	MEF 115-6	
CB	550 F1,F2,K3	CB550K	75-		MCC 111-7	MEF 109-6	
CBX	550 F,F2	PC04	82-85		MCC 117-6	MEF 126-4	MES 333-5
CB	600 Hornet	PC34A	98-01		MCC 124-9	MEF 145-4	MES 343-8
CB	600 Hornet	PC34A	98-02	Superkit	MSK 206		
CB	600 Hornet	PC36	02-06		MCC 124-9	MEF 145-4	MES 343-8
CB	600 Hornet	PC36	02-06	Superkit	MSK 206		
CB	600 Hornet	PC41	07-13		MCC 110-8	MEF 149-5	MES 361-7
CBF	600	PC38	04-07		MCC 124-9	MEF 145-4	MES 343-8
CBF	600	PC38	04-07	Superkit	MSK 206		



Adjuster-/Ausgleichs-Kit falls erforderlich – if necessary
 Superkit siehe Seite 4.04 – see page 4.04
 Superkit* ohne Dichtung – without gasket

C (Competition) Hightech Reibmaterial – hightech friction
 PK (Powerkit) Reiblamellen + Stahlscheiben – frictionplates + steelplates
 RAC (Racing) High-Performance Kupplung – high-performance clutch



Honda

CBF	600	PC43	08-12		MCC 110-8	MEF 149-5	MES 361-7
CBR	600 RR	PC37, PC40	03-15		MCC 110-8	MEF 149-5	MES 330-7
CBR	600 F	PC19	87-88		MCC 117-6	MEF 112-4	MES 333-5
CBR	600 F	PC23	89-90		MCC 117-6	MEF 147-4	MES 333-5
CBR	600 F	PC25	91-94		MCC 124-9	MEF 145-4	MES 343-8
CBR	600 F	PC25	91-94	Superkit	MSK 206		
CBR	600 F	PC31	95-98		MCC 124-9	MEF 145-4	MES 343-8
CBR	600 F	PC31	95-98	Superkit	MSK 206		
CBR	600 F	PC35	99-01		MCC 145-7	MEF 129-5	MES 343-6
CBR	600 F	PC35	02-06		MCC 110-8	MEF 145-6	MES 361-7
CBR	600 F	PC35	02-07	Superkit*	MSK 103		
CBR	600 F		11-15		MCC 110-8	MEF 145-6	MES 361-7
CBR	600 F		11-15	Superkit*	MSK 103		
CBR	600 F, Sport	PC35	01-02		MCC 110-8	MEF 145-6	MES 330-7
VT	600 C	PC21	88-90		MCC 118-7	MEF 133-4	MES 326-6
VT	600 C	PC21	91-00		MCC 118-7	MEF 133-4	MES 334-6
XL	600 LM	PD04	85-86		MCC 116-7	MEF 116-4	MES 332-6
XL	600 LM	PD04	85-86	Superkit	MSK 207		
XL	600 R	PD03	83-87		MCC 116-7	MEF 116-4	MES 332-6
XL	600 R	PD03	83-87	Superkit	MSK 207		
XL	600 V Transalp	PD06	87-99		MCC 118-7	MEF 133-4	MES 334-6
XR	600 R	PE04	85-00		MCC 116-7	MEF 116-4	MES 332-6
CB	650	RC03	79-81		MCC 119-8	MEF 109-6	
CB	650 C	RC05	80-81		MCC 119-8	MEF 109-6	
CB	650 SC	RC08	82-85		MCC 139-6	MEF 109-6	
CBR	650 F		14-		MCC 118-7		MES 343-6
CBX	650 E	RC13	83-		MCC 139-6		MES 333-5
CX	650 C	RC11	83-85		MCC 119-8	MEF 112-4	
CX	650 E	RC12	83-85		MCC 119-8	MEF 112-4	
FMX	650	RD12	05-08		MCC 116-7	MEF 116-4	MES 332-6
FMX	650	RD12	05-08	Superkit	MSK 207		
FX	650 Vigor	RD09	99-00		MCC 116-7	MEF 116-4	MES 332-6
FX	650 Vigor	RD09	99-00	Superkit	MSK 207		
GL	650 D	RC10	83-86		MCC 119-8	MEF 112-4	
NTV	650 V Deauville	RC47	98-05		MCC 120-8	MEF 133-4	MES 336-7
NTV	651 V Deauville	RC47	98-05	Superkit*	MSK 102		
NTV	650 Revere	RC33	88-97		MCC 120-8	MEF 133-4	MES 336-7
NTV	651 Revere	RC33	88-97	Superkit*	MSK 102		
NX	650 Dominator	RD02	88-96		MCC 116-7	MEF 116-4	MES 332-6
NX	650 Dominator	RD02	88-96	Superkit	MSK 207		
NX	650 Dominator	RD08	97-02		MCC 116-7	MEF 116-4	MES 332-6
NX	650 Dominator	RD08	97-02	Superkit	MSK 207		
SLR	650	RD09	97-98		MCC 116-7	MEF 116-4	MES 332-6
SLR	650	RD09	97-98	Superkit	MSK 207		
XL	650 V Transalp	RD10	00-01		MCC 120-8	MEF 128-6	MES 336-7
XL	650 V Transalp	RD10	00-01	Superkit*	MSK 101		
XL	650 V Transalp	RD11	02-07		MCC 120-8	MEF 128-6	MES 336-7
XL	650 V Transalp	RD11	02-07	Superkit*	MSK 101		
XR	650 L		93-14		MCC 116-7	MEF 116-4	MES 332-6
XR	650 R	RE01	01-07		MCC 154-7	MEF 145-4	MES 332-6
XRV	650 Africa Twin	RD03	88-90		MCC 120-8	MEF 128-6	MES 336-7
XRV	650 Africa Twin	RD03	88-90	Superkit*	MSK 101		
CTX	700		14-		MCC 120-8	MEF 133-4	MES 336-7
NC	700		12-13		MCC 120-8	MEF 133-4	MES 336-7
NT	700 Deauville	RC52	06-09		MCC 120-8	MEF 133-4	MES 336-7
NT	700 Deauville	RC52	06-09	Superkit*	MSK 102		
NT	700 Deauville	RC59	10-13		MCC 120-8	MEF 133-4	MES 336-7
NT	700 Deauville	RC59	10-13	Superkit*	MSK 102		
TRX	700		08-11		MCC 162-8	MEF 132-6	MES 335-7
XL	700 Transalp	RD13	07-09		MCC 120-8	MEF 133-4	MES 336-7
XL	700 Transalp	RD13	07-09	Superkit*	MSK 102		
XL	700 Transalp	RD15	10-11		MCC 120-8	MEF 133-4	MES 336-7
XL	700 Transalp	RD15	10-11	Superkit*	MSK 102		
CB	750 C	RC06	81-82		MCC 121-8	MEF 109-6	
CB	750 F	RC04	78-82		MCC 121-8	MEF 109-6	
CB	750 F2	RC04	78-82		MCC 121-8	MEF 109-6	



Honda

CB	750 K	RC01	79-81		MCC 121-8	MEF 109-6	
CB	750 Seven Fifty	RC42	92-01		MCC 148-7	MEF 106-4	MES 335-6
CBX	750 F	RC17	84-86		MCC 122-6		MES 329-5
RVF	750 R	RC45	94-97		MCC 141-8		
VF	750 C	RC09	82-84		MCC 122-6	MEF 111-5	MES 329-5
VF	750 S	RC07	82-87		MCC 122-6	MEF 111-5	MES 329-5
VF	750 F	RC15	83-87		MCC 123-7		MES 329-6
VF	750 C		93-00		MCC 124-9	MEF 128-6	MES 343-8
VFR	750 F	RC24	86-89		MCC 124-9	MEF 128-6	MES 343-8
VFR	750 F	RC36	90-99		MCC 124-9	MEF 128-6	MES 343-8
VFR	750 R	RC30	88-92		MCC 125-10		
VT	750 DC Black Widow	RC48	00-04		MCC 120-8	MEF 128-6	MES 336-7
VT	750 DC Black Widow	RC48	00-04	Superkit*	MSK 101		
VT	750 DC Shadow Spirit		07-09		MCC 120-8	MEF 128-6	MES 336-7
VT	750 DC Shadow Spirit		07-09	Superkit*	MSK 101		
VT	750 C	RC29	86-		MCC 122-6		
VT	750 C Shadow, Shadow Spirit	RC53	10-14		MCC 120-8	MEF 128-6	MES 336-7
VT	750 C Shadow, Shadow Spirit	RC53	10-14	Superkit*	MSK 101		
VT	750 S		10-13		MCC 120-8	MEF 128-6	MES 336-7
VT	750 S		10-13	Superkit*	MSK 101		
VT	750 C Shadow	RC44	97-09		MCC 120-8	MEF 128-6	MES 336-7
VT	750 C Shadow	RC44	97-09	Superkit*	MSK 101		
XLV	750 R	RD01	83-89		MCC 122-6	MEF 159-5	
XRV	750 Afrika Twin	RD04	90-92		MCC 123-7	MEF 106-6	MES 329-6
XRV	750 Afrika Twin	RD07	93-02		MCC 123-7	MEF 106-6	MES 329-6
PC	800 Pacific Coast	RC34	89-98		MCC 123-7	MEF 130-6	
VFR	800	RC46	98-99		MCC 124-9	MEF 129-5	MES 343-8
VFR	800	RC46	00-01		MCC 152-8	MEF 129-5	MES 330-7
VFR	800	RC46	02-13		MCC 110-8	MEF 129-5	MES 330-7
VFR	800	RC79	14-		MCC 110-8	MEF 129-5	MES 361-7
CB	900 F Hornet	SC48	02-07		MCC 110-8	MEF 145-6	MES 330-7
CB	900 F Hornet	SC48	02-07	Superkit	MSK 202		
CB	900 F2	SC09	82-		MCC 121-8	MEF 109-6	
CBR	900 RR	SC28	92-95		MCC 124-9	MEF 128-6	MES 327-8
CBR	900 RR	SC33	96-97		MCC 149-10	MEF 145-6	
CBR	900 RR	SC33D	98-99		MCC 110-8	MEF 145-6	MES 330-7
CBR	900 RR	SC33D	98-99	Superkit	MSK 202		
CBR	900 RR	SC44	00-01		MCC 124-9	MEF 145-6	MES 327-8
CBR	900 RR	SC44	00-01	Superkit*	MSK 100		
CBR	954 RR	SC50	02-03		MCC 124-9	MEF 145-6	MES 327-8
CBR	954 RR	SC50	02-03	Superkit*	MSK 100		
CB	1000 Super Four	SC30	93-95		MCC 127-9	MEF 129-5	MES 333-8
CB	1000 R	SC60	08-14		MCC 158-8		MES 362-7
CBF	1000	SC58, SC64	06-13		MCC 158-8		MES 362-7
CBR	1000 F	SC21	87-88		MCC 127-9	MEF 129-5	MES 333-8
CBR	1000 F	SC24	89-99		MCC 127-9	MEF 129-5	MES 333-8
CBR	1000 RR	SC57	04-07		MCC 158-8		MES 362-7
CBR	1000 RR, RA Fireblade ABS	SC59	08-15		MCC 161-9		
GL	1000	ab Motornr.2002384	77-79		MCC 128-8	MEF 110-6	MES 329-6
VF	1000 F,F2	SC15	84-85		MCC 129-9		
VF	1000 R	SC16	84-86		MCC 129-9		
VTR	1000 Firestorm	SC36	97-		MCC 126-10		MES 335-9
VTR	1000 SP-1	SC45	00-01		MCC 151-7	MEF 144-6	MES 328-6
VTR	1000 SP-2	SC45	02-07		MCC 151-7	MEF 144-6	MES 328-6
XL	1000 Varadero	SD01,SD02	99-02		MCC 126-10		MES 335-9
XL	1000 Varadero	SD02	03-11		MCC 141-8		MES 335-7
CB	1100 A		13-		MCC 141-8		MES 335-7
CB	1100 F	SC11	83		MCC 121-8	MEF 109-6	MES 328-7
CB	1100 R	SC08	82		MCC 121-8	MEF 109-6	MES 328-7
CB	1100 SF X-eleven	SC42	00-03		MCC 151-7	MEF 144-6	MES 328-6
CBR	1100 XX	SC35	97-98		MCC 355-9	MEF 120-5	MES 328-8
CBR	1100 XX	SC35	99-08		MCC 151-7	MEF 144-6	MES 328-6
ST	1100 Pan European	SC26	90-97		MCC 142-10	MEF 133-5	MES 335-9



Adjuster-/Ausgleichs-Kit falls erforderlich – if necessary
 Superkit siehe Seite 4.04 – see page 4.04
 Superkit* ohne Dichtung – without gasket

C (Competition) Hightech Reibmaterial – hightech friction
 PK (Powerkit) Reiblamellen + Stahlscheiben – frictionplates + steelplates
 RAC (Racing) High-Performance Kupplung – high-performance clutch



Honda

ST	1100 Pan European	SC26	98-01		MCC 152-10	MEF 133-5	MES 335-9
VF	1100 C	SC12	83		MCC 121-8		
VT	1100 C2	SC32	95-99		MCC 129-9		MES 333-8
VT	1100 C3	SC39	98-02		MCC 129-9		MES 333-8
VT	1100 C	SC23	85-89		MCC 131-6		MES 329-5
VT	1100 C	SC23	94		MCC 131-6		MES 329-5
VFR	1200 F	SC63	10-14		MCC 161-9		
CB	1300 X4	SC39	97-99		MCC 126-10		MES 335-9
CB	1300	SC54	03-09		MCC 141-8	MEF 120-5	MES 335-7
CTX	1300 DX		14-		MCC 365-8		MES 355-7
ST	1300 Pan European	SC51	02-13		MCC 121-8		MES 355-7
VT	1300 CX	SC61	10-14		MCC 121-8		MES 355-7
VTX	1300	SC52	03-08		MCC 121-8		MES 355-7
GL	1500	SC22	88-03		MCC 147-10		
GL	1520 F6C Valkyrie	SC34	97-03		MCC 147-10		
GL	1800 Goldwing	SC47	01-15		MCC 121-8		MES 328-7
VTX	1800	SC46	01-08		MCC 121-8		MES 328-7

Husaberg

FE	400		97-02		MCC 530-7		MES 420-8
FE	400		97-02	Competition	MCC 530-7C		MES 420-8
FS	400		01-05		MCC 530-7		MES 420-8
FS	400		01-05	Competition	MCC 530-7C		MES 420-8
FE	450		07-08		MCC 510-9		MES 357-8
FS	450		07-08		MCC 510-9		MES 357-8
FX	450		04-05		MCC 530-7		MES 420-8
FX	450		04-05	Competition	MCC 530-7C		MES 420-8
FC	470		01-02		MCC 530-7		MES 420-8
FC	470		01-02	Competition	MCC 530-7C		MES 420-8
FE	501		97-05		MCC 530-7		MES 420-8
FE	501		97-05	Competition	MCC 530-7C		MES 420-8
FC	550		01-05		MCC 530-7		MES 420-8
FC	550		01-05	Competition	MCC 530-7C		MES 420-8
FE	550		07-08		MCC 510-9		MES 357-8
FE	600		97-00		MCC 530-7		MES 420-8
FE	600		97-00	Competition	MCC 530-7C		MES 420-8
FE	650		01-06		MCC 530-7		MES 420-8
FE	650		01-06	Competition	MCC 530-7C		MES 420-8
FE	650		07-08		MCC 510-9		MES 357-8
FS	650		01-06		MCC 530-7		MES 420-8
FS	650		01-06	Competition	MCC 530-7C		MES 420-8
FS	650		07-08		MCC 510-9		MES 357-8

Husqvarna

CR	125		00-11		MCC 504-7		
SM	125 S		00-11		MCC 504-7		
TE	125		14-		MCC 504-7		
WR	125		91-97		MCC 227-7		
WR	125		98-11		MCC 504-7		
WRE	125		94-11		MCC 504-7		
CR	150		11-		MCC 504-7		
WR	240		89-95		MCC 204-7		
CR	250		94-98		MCC 204-7		
CR	250		99		MCC 525-9		
FE	250		14-		MCC 511-8		
FE	250		14-		MCC 511-8C		
TC	250		10-		MCC 504-7		MES 310-6
TE	250		11-13		MCC 504-7		
TXC	250		10-13		MCC 504-7		
WR	250	3H	89-98		MCC 204-7		
WR	250		99		MCC 525-9		
WR	250		00-		MCC 138-8		
WR	260		89-95		MCC 204-7		
WR	300		99-13		MCC 138-8		
TE	310		11-13		MCC 504-7		
TXC	310		11-13		MCC 504-7		
FE	350		14-		MCC 511-8		



Husqvarna

FE	350		14-	MCC 511-8C		
WR	360	3H	92-98	MCC 204-7		
WR	360		99	MCC 525-9		
TE	410		95-98	MCC 204-7		
FE	450		14-	MCC 511-8		
FE	450		14-	MCC 511-8C		
FE	501		14-	MCC 511-8		
FE	501		14-	MCC 511-8C		
TC	570		01-04	MCC 217-8		
TE	610		92-97	MCC 204-7		MES 301-6
TE	610		98-04	MCC 138-8		
SM	630		01-09	MCC 304-5	MEF 121-5	MES 301-4

Hyosung

GA	125 Cruise		99-03	MCC 302-5		
GF	125		99-03	MCC 302-5		
GT	125 Naked	GT	04-06	MCC 302-5		
GT	125 R Supersport		07-	MCC 302-5		
GV	125 Aquila		05-09	MCC 302-5		
RT	125 Karion		05-11	MCC 302-5		
XRX	125		00-09	MCC 302-5		
XRX	125 SM		07-08	MCC 302-5		
GT	250 Comet		07-	MCC 541-6		
GV	250 Aquila		04-09	MCC 541-6		
TE	450 Rapier		07-08	MCC 540-7		
GT	650	GT650	04-06	MCC 540-7		
GT	650 S/R		05-07	MCC 540-7		
GT	650 i, R	GT650	07-13	MCC 540-7		
GV	650 Aquila		06-07	MCC 540-7		
GV	650 Aquila i		08-13	MCC 540-7		
ST	700 I		11-	MCC 540-7		

Kawasaki

KX	60		83-99	MCC 223-5	MEF 118-6	
KX	65		00-14	MCC 223-5	MEF 140-6	
KX	80		90-97	MCC 232-6	MEF 135-4	
KX	80		98-00	MCC 134-6	MEF 141-6	MES 309-5
KX	85		01-14	MCC 134-6	MEF 141-6	MES 309-5
KX	110		03-11	MCC 223-5		
KLX	110		02-13	MCC 223-5	MEF 140-6	
EL	125	BN125A	97-07	MCC 226-5	MEF 141-6	MES 326-4
KE	125	K1033	76-81	MCC 200-5	MEF 101-6	
KH	125	KH125	77-80	MCC 200-5	MEF 101-6	
KLX	125		03-06	MCC 302-5	MEF 134-6	MES 347-4
KLX	125		10-14	MCC 513-5		
KMX	125	MX125A	86-87	MCC 134-6	MEF 131-4	
KMX	125	MX125B	95-03	MCC 222-6	MEF 131-4	MES 309-5
KX	125		86-88	MCC 214-7	MEF 101-6	MES 349-7
KX	125		89-93	MCC 210-8	MEF 106-6	MES 349-7
KX	125		94-95	MCC 219-7	MEF 130-6	MES 302-6
KX	125		96-97	MCC 219-7	MEF 130-6	MES 302-6
KX	125		98-02	MCC 224-7	MEF 148-4	MES 302-6
KX	125		03-09	MCC 224-7		MES 302-6
KDX	175	DX175B	81-82	MCC 201-6	MEF 101-6	
KE	175		79-83	MCC 200-5		
Z	200	KZ200A	82-83	MCC 220-6	MEF 107-6	
Z	200	KZ200A	77-81	MCC 219-7	MEF 107-6	
KLF	220 Bayou		88-02	MCC 104-5		MES 310-5
BJ	250 Estrella	BJ250A	94-02	MCC 218-5	MEF 104-4	
EL	250 Eliminator	EL250B	88-95	MCC 216-5	MEF 107-6	MES 303-5
GPZ	250	EX250C	83-88	MCC 204-7	MEF 104-4	
KDX	250	KDX250	94-	MCC 138-8		MES 306-7
KDX	250		82-93	MCC 204-7		



Adjuster-/Ausgleichs-Kit falls erforderlich – if necessary
 Superkit siehe Seite 4.04 – see page 4.04
 Superkit* ohne Dichtung – without gasket

C (Competition) Hightech Reibmaterial – hightech friction
 PK (Powerkit) Reiblamellen + Stahlscheiben – frictionplates + steelplates
 RAC (Racing) High-Performance Kupplung – high-performance clutch



Kawasaki

KH	250	KH250B	76-78		MCC 201-6	MEF 101-6	
KL	250	KL250A	80-84		MCC 219-7	MEF 107-6	
KLF	250 Bayou		03-11		MCC 104-5		MES 310-5
KLR	250	KL250D	80-84		MCC 219-7	MEF 107-6	MES 302-6
KLR	250		85-03		MCC 231-6	MEF 107-6	
KLX	250 F, S		93-14		MCC 214-7		
KSF	250 Mojave		87-04		MCC 231-7		MES 302-6
KX	250		82-84		MCC 204-7	MEF 110-6	
KX	250		87-91		MCC 217-8	MEF 106-6	MES 306-7
KX	250		92-10		MCC 208-8	MEF 107-6	MES 304-7
	250 Ninja R	EX250K	08-12		Anfrage		
KX	250 F		04-14		MCC 339-8		MES 354-7
ZXR	250		89-95		MCC 218-5	MEF 107-6	MES 303-5
EL	252 F	EL250F	96-03		MCC 216-5	MEF 104-4	MES 303-5
KEF	300		01-02		MCC 229-5		
KLF	300		87-05		MCC 229-5	MEF 104-4	
KLX	300	LX300B	97-06		MCC 214-7	MEF 101-6	
GPZ	305	EX305B	84-89		MCC 204-7	MEF 107-6	
GPZ	400 R	KZ400M	83-89		MCC 205-7	MEF 107-6	MES 303-6
GPZ	400 R	ZX400A	85-		MCC 205-7	MEF 107-6	MES 303-6
KH	400		74-79		MCC 227-7		
KLF	400 Bayou		93-99		MCC 505-6		
KLX	400 R		03-04		MCC 217-8	MEF 150-6	
KFX	400	KFX400	03-04		MCC 217-8	MEF 150-6	
Z	400	KZ400J	80-82		MCC 205-7	MEF 110-6	MES 303-6
Z	400 F	ZR400B	84-		MCC 205-7	MEF 107-6	MES 303-6
Z	400	K4	78-80		MCC 206-6	MEF 107-6	
Z	400 G	KTG	79-		MCC 206-6	MEF 107-6	
ZX	400		85-86		MCC 205-7	MEF 110-6	
ZXR	400	ZX400L	91-02		MCC 220-6	MEF 106-4	
Z	440	KZ440C	80-81		MCC 206-6	MEF 107-6	
Z	440	KZ440H	82-83		MCC 206-6	MEF 107-6	MES 303-5
Z	440	KZ440D	82-84		MCC 206-6	MEF 107-6	MES 303-5
Z	440 LTD	KZ440A	80-83		MCC 206-6	MEF 107-6	MES 303-5
KLX	450 R		08-12		MCC 138-8		
KX	450 F		06-11		MCC 138-8		
KX	450 F		12-13		MCC 138-8	MEF 129-5	
Z	450 LTD	EN450A	84-89		MCC 205-7	MEF 123-6	MES 303-6
Z	450 LTD	EN450A	84-89	Superkit	MSK 205		
EN	500	EN500A	90-03		MCC 205-7	MEF 123-6	MES 303-6
EN	500	EN500A	90-03	Superkit	MSK 205		
ER-5	500 Twister	ER500A/B	97-00		MCC 205-7	MEF 110-6	MES 303-6
ER-5	500 Twister	ER500A/B	97-00	Superkit	MSK 220		
ER-5	500 Twister	ER500C/D	01-07		MCC 205-7	MEF 110-6	MES 303-6
ER-5	500 Twister	ER500C/D	01-07	Superkit	MSK 220		
GPZ	500 S	EX500A	87-03		MCC 205-7	MEF 123-5	MES 303-6
GPZ	500 S	EX500A	87-03	Superkit	MSK 205		
KH	500	H1F	76-79		MCC 219-7	MEF 107-6	
KLE	500	LE500A	91-07		MCC 205-7	MEF 123-5	MES 303-6
KLE	500	LE500A	91-07	Superkit	MSK 205		
KX	500		84		MCC 204-7	MEF 107-6	
KX	500 D		88-04		MCC 217-8	MEF 107-6	MES 306-7
GPZ	550	ZX550A	84-89		MCC 205-7	MEF 110-6	MES 303-6
GT	550	KZ500G	83-90		MCC 205-7	MEF 110-6	MES 303-6
Z	550	KZ550B	81-		MCC 205-7	MEF 110-6	MES 303-6
Z	550 F	KZ550B	83-		MCC 205-7	MEF 107-6	MES 303-6
Z	550 GP	KZ550H	82-83		MCC 205-7	MEF 107-6	MES 303-6
ZR	550 Zephyr	KZ550A	83-84		MCC 205-7	MEF 110-6	MES 303-6
ZR	550 Zephyr	ZR550B	91-96		MCC 205-7	MEF 110-6	MES 303-6
GPX	600 R	ZX600C	88-00		MCC 205-7	MEF 110-6	MES 303-6
GPZ	600 R	ZX600A	85-89		MCC 205-7	MEF 110-6	MES 303-6
KLR	600	KL600B	84-93		MCC 205-7	MEF 110-6	MES 303-6
ZL	600 Eliminator	ZL600A	85-87		MCC 205-7	MEF 123-6	MES 303-6
ZL	600 Eliminator	ZL600B	96-97		MCC 205-7	MEF 123-6	MES 303-6
ZX-6R	600 Ninja	ZX600F	95-97		MCC 221-9	MEF 146-4	MES 310-9
ZX-6R	600 Ninja	ZX600G	98-99		MCC 221-9	MEF 146-4	MES 310-9



Kawasaki

ZX-6R	600 Ninja	ZX600H	00-01		MCC 221-9	MEF 146-4	
ZX-6R	600 Ninja	ZX600B	03-04		MCC 221-9	MEF 146-4	MES 354-8
ZX-6R	600 Ninja	ZX600B	03-04	Adjuster-Kit			Anfrage
ZX-6R	600 Ninja	ZX600P	07-14		MCC 339-8		Anfrage
ZX-6RR	600	ZX600K	03		MCC 221-9	MEF 146-4	
ZX-6RR	600 Ninja	ZX600N1	05-06		MCC 339-8		
ZZR	600	ZX600D	90-92		MCC 205-7	MEF 107-6	MES 305-6
ZZR	600	ZX600E	93-07		MCC 205-7	MEF 144-5	MES 305-6
ZX-6R	636 Ninja	ZX636A/B	02-04		MCC 221-9	MEF 146-4	
ZX-6R	636 Ninja	ZX636C	05-06		MCC 339-8		
ER-6	650 N,F	EX650A	06-08		MCC 205-7	MEF 110-6	
ER-6	650 N,F	EX650C	09-14		MCC 205-7	MEF 110-6	
KLE	650 Versys	LE650A/C	07-14		MCC 205-7	MEF 110-6	
KLR	650	KL650A	87-92		MCC 205-7	MEF 107-6	MES 303-6
KLR	650	KL650C	95-05		MCC 208-8	MEF 130-6	MES 303-7
KLX	650	KLX650C	93-99		MCC 205-7	MEF 107-6	MES 303-6
W	650	EJ650A1	99-05		MCC 208-8	MEF 123-5	MES 304-7
Z	650	B	77-78		MCC 207-7	MEF 107-6	
Z	650	KZ650C	78-79		MCC 207-7	MEF 107-6	
Z	650	KZ650D	79-80		MCC 207-7	MEF 107-6	
Z	650	KZ650F	81-83		MCC 207-7	MEF 107-6	
GPX	750 R	ZX750F	85-89		MCC 208-8	MEF 130-6	MES 304-7
GPZ	750	ZX750A	83-85		MCC 207-7	MEF 107-6	
GPZ	750 R1		82		MCC 207-7	MEF 107-6	
GPZ	750 R	ZX750G	85-86		MCC 208-8	MEF 110-6	
VN	750	VN750A	86-95		MCC 208-8	MEF 107-6	MES 304-7
Z	750	KZ750E	81-84		MCC 207-7	MEF 107-6	
Z	750		84-		MCC 207-7	MEF 107-6	
Z	750 E	KZ750E	80		MCC 207-7	MEF 107-6	
Z	750 GT	KZ750P	82-85		MCC 207-7	MEF 107-6	
Z	750 LTD	KZ750H	80-82		MCC 207-7	MEF 107-6	
Z	750 LTD	KZ750Y	82-83		MCC 208-8	MEF 107-6	MES 304-7
Z	750 LTD	KZ750K	83		MCC 208-8	MEF 107-6	
Z	750	KZ750B	76-79		MCC 208-8	MEF 107-6	
Z	750	ZR750J/L	04-10		MCC 221-9	MEF 146-4	MES 354-8
Z	750	ZR750J/L	04-10	Adjuster-Kit			Anfrage
Z	750 , R	ZR750N	11-12		MCC 221-9	MEF 146-4	MES 354-8
Z	750 , R	ZR750N	11-12	Adjuster-Kit			Anfrage
ZR	750 Zephyr	ZR750C	91-94		MCC 209-7	MEF 110-6	
ZR	750 Zephyr	ZR750C	95-98		MCC 209-7	MEF 138-6	
ZR-7	750	ZR750F	99-04		MCC 209-7	MEF 138-6	
ZX-7R	750 Ninja	ZX750P	96-01		MCC 208-8	MEF 164-6	
ZX-7R	750 Ninja	ZX750P	02-		MCC 208-8	MEF 164-6	
ZXR	750	ZX750H	89-90		MCC 205-7	MEF 123-6	
ZXR	750	ZX750J/L	91-95		MCC 208-8	MEF 164-6	
ZXR	750 R	ZX750K/M	91-95		MCC 208-8	MEF 164-6	
VN	800	VN800A/B	95-05		MCC 208-8	MEF 107-6	MES 304-7
VN	800	VN800A/B	95-05	Superkit	MSK 210		
VN	800 Drifter	VN800C	01-04		MCC 208-8	MEF 107-6	MES 308-7
W	800	EJ800A	11-14		MCC 208-8	MEF 110-6	
Z	800 , ABS, e	ZR800A,B,C,D	13-14		MCC 221-9	MEF 146-4	
GPZ	900 R	ZX900A	84-91		MCC 208-8	MEF 107-6	MES 304-7
VN	900 Classic	VN900B	06-14		MCC 208-8	MEF 110-6	MES 304-7
VN	900 Classic	VN900B	06-14	Superkit	MSK 219		
VN	900 Custom	VN900C	07-14		MCC 208-8	MEF 110-6	MES 304-7
VN	900 Custom	VN900C	07-14	Superkit	MSK 219		
Z	900	Z1F	76-77		MCC 215-8	MEF 107-6	
ZX-9R	900 Ninja	ZX900B	94-97		MCC 208-8	MEF 138-6	
ZX-9R	900 Ninja	ZX900C	98-99		MCC 213-10	MEF 105-5	
ZX-9R	900 Ninja	ZX900D/E	00-01		MCC 213-10	MEF 105-5	MES 310-9
ZX-9R	900 Ninja	ZX900D/E	00-01	Superkit	MSK 209		
ZX-9R	900 Ninja	ZX900F	02-04		MCC 213-10	MEF 105-5	MES 310-9
ZX-9R	900 Ninja	ZX900F	02-04	Superkit	MSK 209		



Adjuster-/Ausgleichs-Kit falls erforderlich – if necessary
 Superkit siehe Seite 4.04 – see page 4.04
 Superkit* ohne Dichtung – without gasket

C (Competition) Hightech Reibmaterial – hightech friction
 PK (Powerkit) Reiblamellen + Stahlscheiben – frictionplates + steelplates
 RAC (Racing) High-Performance Kupplung – high-performance clutch



Kawasaki

GPZ	1000 RX	ZXT00A	86-89		MCC 211-9	MEF 123-6	MES 305-8
GPZ	1000 RX	ZXT00A	86-89	Superkit	MSK 218		
GTR	1000	ZGT00A	86-03		MCC 211-9	MEF 123-6	MES 305-8
GTR	1000	ZGT00A	86-03	Adjuster-Kit			Anfrage
GTR	1000	ZGT00A	86-03	Superkit	MSK 218		
KLV	1000	LV1000A	04-05		MCC 349-10	MEF 144-5	MES 410-9
Z	1000	KZT00A	81-82		MCC 211-9	MEF 107-6	
Z	1000 LTD	KZT00J	81		MCC 211-9	MEF 107-6	
Z	1000 ST	KZT00E	79-83		MCC 211-9	MEF 123-5	MES 305-8
Z	1000	ZRT00A/B/C/D	03-12		MCC 213-10	MEF 105-5	MES 310-9
Z	1000	ZRT00A/B/C/D	03-12	Superkit	MSK 211		
Z	1000 SX	ZXT00G	11-14		MCC 213-10		
Z	1000	KZT00A	77-78		MCC 215-8	MEF 107-6	
Z	1000	KZT00H	80		MCC 215-8	MEF 107-6	
Z	1000 MK2	KZT00A	79-80		MCC 215-8	MEF 107-6	
Z	1000 Z1R	KZT00D	78		MCC 215-8	MEF 107-6	
ZL	1000	ZLT00A	87-88		MCC 211-9	MEF 123-6	MES 305-8
ZL	1000	ZLT00A	87-88	Superkit	MSK 218		
ZX-10	1000	ZXT00B	88-90		MCC 211-9	MEF 123-6	
ZX-10R	1000 Ninja	ZXT00C,D, E,F	04-14		MCC 213-10		
GPZ	1100	KZT10B	81-85		MCC 211-9	MEF 107-6	MES 305-8
GPZ	1100	ZXT10E	95-98		MCC 212-9	MEF 143-6	MES 311-8
Z	1100 ST	KZT10A	81-83		MCC 211-9	MEF 107-6	
ZR	1100 Zephyr	ZRT10A/B	92-97		MCC 211-9	MEF 123-6	MES 305-8
ZRX	1100	ZRT10C	97-00		MCC 211-9	MEF 123-6	MES 305-8
ZRX	1100	ZRT10C	97-00	Superkit	MSK 218		
ZZR	1100	ZXT10C,D,G	90-01		MCC 212-9	MEF 143-6	MES 311-8
ZG	1200		86-97		MCC 211-9		MES 305-8
ZRX	1200	ZRT20A	01-08		MCC 211-9	MEF 138-6	MES 305-8
ZX-12	1200	ZXT20A	01-03		MCC 225-12	MEF 105-5	MES 312-11
ZX-12	1200	ZXT20B	04-06		MCC 225-12	MEF 105-5	MES 312-11
ZZR	1200	ZX1200C	02-05		MCC 212-9	MEF 129-5	MES 311-8
GTR	1400	ZG1400A,C	07-14		MCC 349-10	MEF 123-6	
ZZR	1400	ZXT40A,C	06-14		MCC 349-10		
VN	1500	VNT50A	88-96		MCC 230-8		
VN	1500 Classic	VNT50D	96-02		MCC 230-8		
VN	1500 Drifter	VNT50J	99-03		MCC 230-8		
VN	1500 Mean Streak	VNT50P	02-03		MCC 230-8		
VN	1600 Classic	VNT60A	03-08		MCC 230-8		
VN	1600 Mean Streak	VNT60B	04-08		MCC 230-8		
VN	1700		09-14		Anfrage		
VN	2000	VNW00A	04-09		Anfrage	MEF 146-4	

KTM

MXC	50		87-		MCC 506-6		
RSV	50		86-		MCC 506-6		
SX	50 Adventure		98-		MCC 506-6		
SX	60		96-00		MCC 506-6		
SX	65		96-14		MCC 506-6		
SX	85		03-14		MCC 507-7	MEF 142-5	
	125 Duke		11-14		MCC 513-5		MES 371-4
EXC	125		90-97		MCC 500-8		
EXC	125		98-13		MCC 504-7	MEF 124-6	MES 419-6
EXE	125		01-		MCC 504-7	MEF 142-5	
GS	125		84-89		MCC 500-8		
SX	125		95-97		MCC 500-8		
SX	125		98-14		MCC 504-7	MEF 124-6	
SX	150		09-13		MCC 504-7	MEF 158-6	MES 419-6
SX	150		09-13	Superkit	MSK 221		
XC	150		11-13		MCC 504-7	MEF 158-6	MES 419-6
XC	150		11-13	Superkit	MSK 221		
	200 Duke		12-		MCC 222-6		
EXC	200		98-14		MCC 504-7	MEF 158-6	MES 419-6
EXC	200		98-14	Superkit	MSK 221		
SX	200		90-07		MCC 504-7	MEF 158-6	MES 419-6
SX	200		90-07	Superkit	MSK 221		

**KTM**

EGS	250		94-99		MCC 501-9		MES 350-8
EGS	250		94-99	Competition	MCC 501-9C		MES 350-8
EXC	250	Racing- 4T	02-03		MCC 530-7		MES 420-8
EXC	250	Racing- 4T	02-03	Competition	MCC 530-7C		MES 420-8
EXC	250	Racing- 4T	04-05		MCC 508-7		
EXC	250	Racing- 4T	04-05	Competition	MCC 508-7C		
EXC	250		96-12		MCC 501-9		MES 350-8
EXC	250		96-12	Competition	MCC 501-9C		MES 350-8
EXC-F	250	4 T	06-13		MCC 157-8		
EXC	250	4 T	08-		MCC 133-8		MES 356-7
MXC	250		98-99		MCC 501-9		MES 350-8
MXC	250		98-99	Competition	MCC 501-9C		MES 350-8
SX	250		96-12		MCC 501-9		MES 350-8
SX	250		96-12	Competition	MCC 501-9C		MES 350-8
SX	250	2 T	13-14		MCC 511-8		MES 421-9
SX	250	2 T	13-14	Competition	MCC 511-8C		MES 421-9
SX-F	250	4 T	07-12		MCC 157-8		MES 310-7
SX-F	250	2 T	13-14		MCC 511-8		MES 421-9
SX-F	250	2 T	13-14		MCC 511-8C		MES 421-9
XC-F	250	4 T	11-12		MCC 157-8		
XC-F	250		13-		MCC 511-8	MEF 158-6	MES 421-9
XC-F	250		13-		MCC 511-8C	MEF 158-6	MES 421-9
XC-W	250		11-12		MCC 501-9		MES 350-8
XC-W	250		11-12	Competition	MCC 501-9C		MES 350-8
XC-W	250		13-		MCC 511-8		MES 421-9
XC-W	250		13-		MCC 511-8C		MES 421-9
EGS	300		94-99		MCC 501-9		MES 350-8
EGS	300		94-99	Competition	MCC 501-9C		MES 350-8
EXC	300		96-12		MCC 501-9		MES 350-8
EXC	300		96-12	Competition	MCC 501-9C		MES 350-8
EXC	300		13-14		MCC 511-8		MES 421-9
EXC	300		13-14	Competition	MCC 511-8C		MES 421-9
MXC	300		94-05		MCC 501-9		MES 350-8
MXC	300		94-05	Competition	MCC 501-9C		MES 350-8
XC	300		11-12		MCC 501-9		
XC	300		11-12	Competition	MCC 501-9C		
EXC	350		12-13		MCC 511-8		
EXC	350		12-13	Competition	MCC 511-8C		
	350 Freewide		12-14		MCC 511-8		MES 422-8
	350 Freewide		12-14	Competition	MCC 511-8C		MES 422-8
	350 SX-F	4T	11-14		MCC 511-8	MEF 158-6	
	350 SX-F	4T	11-14	Competition	MCC 511-8C	MEF 158-6	
	350 XC-F		12-13		MCC 511-8	MEF 158-6	
	350 XC-F		12-13	Competition	MCC 511-8C	MEF 158-6	
	350 XCF-W		12-13		MCC 511-8		
	350 XCF-W		12-13	Competition	MCC 511-8C		
EXC	360		96-97		MCC 501-9		MES 350-8
EXC	360		96-97	Competition	MCC 501-9C		MES 350-8
MXC	360		96-01		MCC 501-9		MES 350-8
MXC	360		96-01	Competition	MCC 501-9C		MES 350-8
SX	360		96-97		MCC 501-9		MES 350-8
SX	360		96-97	Competition	MCC 501-9C		MES 350-8
EXC	380		98-02		MCC 501-9		MES 350-8
EXC	380		98-02	Competition	MCC 501-9C		MES 350-8
SX	380		98-02		MCC 501-9		MES 350-8
SX	380		98-02	Competition	MCC 501-9C		MES 350-8
EXC	400		93-95		MCC 505-6	MEF 111-5	
EXC	400		96-97		MCC 503-8		
EXC	400		96-97	Competition	MCC 503-8C		
EXC	400		00-01		MCC 530-7		
EXC	400		00-01	Competition	MCC 530-7C		
EXC	400 Racing		00-04		MCC 530-7		MES 420-8
EXC	400 Racing		00-04	Competition	MCC 530-7C		MES 420-8



Adjuster-/Ausgleichs-Kit falls erforderlich – if necessary
 Superkit siehe Seite 4.04 – see page 4.04
 Superkit* ohne Dichtung – without gasket

C (Competition) Hightech Reibmaterial – hightech friction
 PK (Powerkit) Reiblamellen + Stahlscheiben – frictionplates + steelplates
 RAC (Racing) High-Performance Kupplung – high-performance clutch

**KTM**

EXC	400 Racing		05		MCC 508-7		
EXC	400 Racing		05	Competition	MCC 508-7C		
LC4	400		98-99		MCC 502-8		MES 351-7
SC	400		96-97		MCC 502-8		MES 351-7
SC	400		93-95		MCC 505-6		
SX	400		00		MCC 502-8		MES 351-7
SX	400 Racing		00-04		MCC 530-7		MES 420-8
SX	400 Racing		00-04	Competition	MCC 530-7C		MES 420-8
SX	400 Racing		05		MCC 508-7		
SX	400 Racing		05	Competition	MCC 508-7C		
SXC	400		97		MCC 503-8		
SXC	400		97	Competition	MCC 503-8C		
SXC	400		98-99		MCC 502-8		MES 351-7
	450 SMR		04-09		MCC 508-7		
	450 SMR		04-09	Competition	MCC 508-7C		
	450 SMS		04		MCC 508-7		
	450 SMS		04	Competition	MCC 508-7C		
EXC	450 Racing		04-05		MCC 508-7		
EXC	450 Racing		04-05	Competition	MCC 508-7C		
EXC	450		12-14		MCC 511-8		
EXC	450		12-14	Competition	MCC 511-8C		
SX	450		04-06		MCC 508-7		
SX	450		04-06	Competition	MCC 508-7C		
SX	450		09-11		MCC 510-9		MES 357-8
SX-F	450	4T	07-11		MCC 510-9		MES 357-8
SX-F	450		12-14		MCC 511-8		
SX-F	450		12-13	Competition	MCC 511-8C		
SX	450 Racing		03		MCC 530-7		MES 420-8
SX	450 Racing		03	Competition	MCC 530-7C		MES 420-8
SX	450 Racing		04-05		MCC 508-7		
SX	450 Racing		04-05	Competition	MCC 508-7C		
XC	450		08-09		MCC 508-7		
XC	450		08-09	Competition	MCC 508-7C		
XC-W	450		12-13		MCC 511-8		
XC-W	450		12-13	Competition	MCC 511-8C		
EXC	500		12-14		MCC 511-8		
EXC	500		12-14	Competition	MCC 511-8C		
XC-W	500		12-13		MCC 511-8		
XC-W	500		12-13	Competition	MCC 511-8C		
SX	505		09-10		MCC 510-9		MES 357-8
SX-F	505		07-12		MCC 508-7		
SX-F	505		07-12	Competition	MCC 508-7C		
SX	520 Racing		00-02		MCC 530-7		MES 420-8
SX	520 Racing		00-02	Competition	MCC 530-7C		MES 420-8
EXC	525 Racing		03		MCC 530-7		MES 420-8
EXC	525 Racing		03	Competition	MCC 530-7C		MES 420-8
EXC	525 Racing		04-05		MCC 508-7		
EXC	525 Racing		04-05	Competition	MCC 508-7C		
SX	525		04		MCC 508-7		
SX	525		04	Competition	MCC 508-7C		
SX	525 Racing		03		MCC 530-7		MES 420-8
SX	525 Racing		03	Competition	MCC 530-7C		MES 420-8
SX	525 Racing		04-06		MCC 508-7		
SX	525 Racing		04-06	Competition	MCC 508-7C		
	525 XC		08-12		MCC 508-7		
	525 XC		08-12	Competition	MCC 508-7C		
	540 SXC		98-99		MCC 502-8		MES 351-7
	560 SMR		06-07		MCC 508-7		
	560 SMR		06-07	Competition	MCC 508-7C		
	600 EXC		93		MCC 505-6		
	620 EGS		95-98		MCC 503-8		
	620 EGS		95-98	Competition	MCC 503-8C		
EXC	620		95-98		MCC 503-8		
	620 EXC		95-98	Competition	MCC 503-8C		
LC4	620		94-95		MCC 505-6		
SX	620		95-99		MCC 503-8		



KTM

SX	620		95-99	Competition	MCC 503-8C		
	620 Duke		93-97		MCC 502-8		MES 351-7
	625 SXC/SMC		02-07		MCC 502-8		MES 351-7
	625 Duke, Duke II		99-05		MCC 502-8		MES 351-7
LC4	625 Adventure		02-05		MCC 502-8		MES 351-7
LC4	625 SM		02-05		MCC 502-8		MES 351-7
LC4	625 SM		02-		MCC 502-8		MES 351-7
LC4	640 Adventure		02-05		MCC 502-8		MES 351-7
LC4	640 Duke, Duke II		99-05		MCC 502-8		MES 351-7
LC4	640 Supermoto	KTM-4T-EGS	02-		MCC 502-8		MES 351-7
LC4	660 SMC Supermoto	4T-SC	02-05		MCC 502-8		MES 351-7
	690 Duke		08-14		MCC 512-8		MES 375-7
	690 Enduro		08-14		MCC 512-8		MES 375-7
	690 SM		07-09		MCC 512-8		MES 375-7
	690 SMC		08-13		MCC 512-8		MES 375-7
	690 SMR		07-13		MCC 512-8		MES 375-7
	950 Adventure		03-06		MCC 509-11		
	950 Superenduro		07-08		MCC 509-11		
	990 Adventure		06-12		MCC 509-11		
	990 Superduke		06-12		MCC 509-11		
	990 Supermoto	LC8EFI	08-13		MCC 509-11		
	1190	RC8	08-14		MCC 349-10		MES 328-9

Laverda

	125 Navarro		90		MCC 227-7		
	650 Formula		95				MES 351-7
	668 Ghost	ZLVSPA	95-97				MES 351-7
	668 Sport	ZLVSPA	96				MES 351-7

Loncin

	200 Conqueror		05-		MCC 134-6		
--	---------------	--	-----	--	-----------	--	--

Malaguti

X3M	125 Enduro/Motard		08-		MCC 403-5		MES 317-4
-----	-------------------	--	-----	--	-----------	--	-----------

Modenas

	110 Kriss				MCC 223-5	MEF 140-6	
--	-----------	--	--	--	-----------	-----------	--

Montesa

	315 R		97-04		MCC 116-7		
--	-------	--	-------	--	-----------	--	--

Moto Guzzi

	1000 Idroconvert		75-84		MCC 139-6		
--	------------------	--	-------	--	-----------	--	--

Moto Roma

	300 Geko Quad		04-06		MCC 107-6		
--	---------------	--	-------	--	-----------	--	--

MUZ

SX	125	MZ125	00-07		MCC 201-6		MES 368-6
SM	125	MZ125	00-07		MCC 201-6		MES 368-6
RT	125 Classic		00-07		MCC 201-6		MES 368-6
	660 Skorpion		94-		MCC 416-8	MEF 140-6	

MV Agusta

	675 Brutale		12-		MCC 445-8		
	675 F3		12-		MCC 445-8		
	675 Serie Oro		12-		MCC 445-8		
	750 Brutale S		02-07		MCC 344-9		
	800 Brutale		13-		MCC 358-9		
	800 F3		14-		MCC 358-9		
	800 Rivale		14-		MCC 358-9		
	909 Brutale 910		05-07		MCC 344-9		
	920 Brutale		11-13		MCC 621-10		
	989 Brutale		09-10		MCC 621-10		



Adjuster-/Ausgleichs-Kit falls erforderlich – if necessary
 Superkit siehe Seite 4.04 – see page 4.04
 Superkit* ohne Dichtung – without gasket

C (Competition) Hightech Reibmaterial – hightech friction
 PK (Powerkit) Reiblamellen + Stahlscheiben – frictionplates + steelplates
 RAC (Racing) High-Performance Kupplung – high-performance clutch



MV Agusta

	990 Brutale R		10-11		MCC 621-10		
F4	1000 R, S		04-07		MCC 344-9		
F4	1000 R	F511	08-12		MCC 621-10		
F4	1000 R, RR	F630	12-		MCC 621-10		
	1078 Brutale RR	F413	08-10		MCC 621-10		
F4	1078 RR		08-10		MCC 621-10		
	1090 Brutale Corse		14-		MCC 621-10		
	1090 Brutale RR	B520	10-11		MCC 621-10		
	1090 Brutale RR	FVU	12-		MCC 621-10		

Peugeot

XPS	125		06-07		MCC 403-5		MES 317-4
-----	-----	--	-------	--	-----------	--	-----------

Polaris

	500 Predator		03-07		MCC 445-8		
--	--------------	--	-------	--	-----------	--	--

Rieju

	50 Drac		92-		MCC 550-4		
	50 Spike		01-07		MCC 550-4		
MRT	50 SM		09-10		MCC 550-4		
MRX	50	MRX	01-07		MCC 550-4		
RR	50	RR	97-		MCC 550-4		
SMX	50		01-07		MCC 550-4		
	50 Matrix		03-07		MCC 403-5		MES 317-4
	50 RS 1		96-01		MCC 403-5		MES 317-4
	50 RS 2		06-07		MCC 403-5		MES 317-4
MRX	125	MR4T	06-07		MCC 403-5		MES 317-4
SMX	125	MR4T	06-07		MCC 403-5		MES 317-4
	125 Apache		02-03		MCC 439-7		MES 317-6
	125 Tango		06-07		MCC 403-5		MES 317-4
	125 RS 2		06-07		MCC 403-5		MES 317-4

Sachs

XTC	125 Racing	675	00-07		MCC 302-5	MEF 134-6	
	125 X-Road		06-07		MCC 302-5	MEF 134-6	

Scorpa

SY	125 F		07-		MCC 403-5		MES 317-4
SY	250		04-07				MES 321-7

Sherco

0.5	50 Kid		03-06		MCC 550-4		
	50 Enduro		03-07		MCC 550-4		

Suzuki

GT	50		77-		MCC 300-3	MEF 101-6	
GT	50	GT50	79-		MCC 300-3	MEF 101-6	
GT	50 K	GT50K	77-80		MCC 300-3	MEF 101-6	
JR	50		78-07		MCC 364-2	MEF 102-6	
TS	50 ERK	TS50XK	79-81		MCC 300-3	MEF 101-6	
TS	50 K	TS50K	78-79		MCC 300-3	MEF 101-6	
TS	50	TS50XK	82-83		MCC 301-4	MEF 101-6	
TS	50		84-86		MCC 302-5	MEF 101-6	
ZR	50 K	ZR50K	79-83		MCC 300-3	MEF 101-6	
RM	65		03-05		MCC 223-5	MEF 140-6	
GT	80 E,L	GT80	81-		MCC 301-4		
JR	80		01-07		MCC 301-4	MEF 101-6	MES 347-4
RG	80 C	NC11A	85-91		MCC 302-5		MES 347-4
RM	80	RC11B/D	-83		MCC 301-4	MEF 101-6	MES 347-4
RM	80	RC11	83-85		MCC 302-5	MEF 101-6	MES 347-4
RM	80	RC12A	86-01		MCC 302-5	MEF 114-6	MES 345-4
TS	80 ER	TS80	81-82		MCC 301-4		
TS	80 X	SC11A	84-86		MCC 302-5		
RM	85		02-13		MCC 302-5	MEF 114-6	MES 345-4
DR-Z	110		03-05		MCC 223-5	MEF 140-6	
DR	125 S	SF42A	82-94		MCC 302-5	MEF 134-6	MES 345-4
DR	125 S	SF44A	99-01		MCC 302-5	MEF 134-6	MES 345-4



Suzuki

DR	125 SM	CS	08-12		MCC 330-5	MEF 134-6	
DR-Z	125		03-13		MCC 302-5	MEF 134-6	MES 347-4
GN	125	NF41A	82-97		MCC 302-5	MEF 134-5	MES 347-4
GP	125	GP125	78-81		MCC 303-6	MEF 125-7	
GT	125	GT125	74-78		MCC 302-5	MEF 125-7	
GT	125 E	GT125	78-79		MCC 302-5	MEF 125-7	
GZ	125 Marauder	A	98-99		MCC 302-5	MEF 134-5	MES 347-4
GZ	125 Marauder	AP	02-11		MCC 302-5	MEF 134-5	MES 347-4
RG	125 Gamma		85-91		MCC 303-6	MEF 125-7	
RG	125 Gamma	NF13	92-95		MCC 303-6	MEF 134-6	
RM	125	RF13A	84-85		MCC 305-7	MEF 134-6	
RM	125	RF13A	86-88		MCC 303-6	MEF 101-6	
RM	125	RF14A	89-91		MCC 336-8	MEF 114-6	
RM	125	RF14A	92-96		MCC 329-8	MEF 134-6	MES 346-7
RM	125	RF15A	97-01		MCC 329-8	MEF 158-6	MES 346-7
RM	125	RF15A	02-12		MCC 339-8	MEF 154-6	MES 346-7
RV	125	RV125	73-77		MCC 302-5		MES 347-4
RV	125 Van Van	WVBT	03-14		MCC 302-5	MEF 134-6	MES 347-4
TS	125	TS1252	74-81		MCC 302-5	MEF 125-7	MES 347-4
TS	125		84-		MCC 303-6	MEF 125-7	
TS	125 ER	TS1252	79-82		MCC 330-5	MEF 125-7	
TU	125 XT	AZ	99-		MCC 302-5	MEF 134-5	MES 347-4
VL	125 Intruder LC	A4	99-01		MCC 346-3	MEF 106-4	MES 301-4
LT-F	160 Quadrunner	AG	91-02		MCC 336-6	MEF 161-4	
VL	125 Intruder LC	WVA4	02-08		MCC 351-3	MEF 106-4	MES 301-4
GT	185	GT185	73-78		MCC 303-6	MEF 125-7	
TS	185 ER	TS185	79		MCC 303-6	MEF 125-7	
GT	200 N, E	GT200	79		MCC 303-6	MEF 125-7	
DR	250 S		82		MCC 304-5		MES 301-4
DR	250 S	SJ42A	84-85		MCC 304-5		MES 301-4
DR	250 S	SJ42A	86-87		MCC 304-5		MES 301-4
DR-Z	250		01-07		MCC 118-7		MES 336-7
GN	250	NJ42A	84-99		MCC 304-5	MEF 106-4	MES 301-4
GN	250 E	NJ42A	82-83		MCC 304-5	MEF 101-6	MES 301-4
GSX	250	GS25X	80-83		MCC 305-7		
GSX	250 E,ES	GJ53B	82		MCC 305-7		
GT	250	GT250	75-78		MCC 307-6	MEF 106-6	
GZ	250 Marauder	AR	99-04		MCC 304-5	MEF 121-5	MES 301-4
LT-F	250 Qzark		02		MCC 336-6	MEF 161-4	MES 345-5
LT-F	250 Qzark		03		MCC 336-7		
LT-F	250 Qzark		04		MCC 363-6		MES 345-5
LT-F	250 Qzark		05-14		MCC 336-7		
LT-Z	250 QuadSport	AJ4AA	04-		MCC 363-6		MES 345-5
RG	250 Gamma	GJ21A	83-91		MCC 331-7	MEF 106-6	MES 337-6
RGV	250	VJ22A	90-94		MCC 309-7	MEF 107-6	MES 337-6
RM	250		79-85		MCC 334-5	MEF 106-6	
RM	250	RJ14A	86-87		MCC 333-6	MEF 134-6	
RM	250	RJ14A	88-91		MCC 328-8	MEF 102-6	MES 337-8
RM	250	RJ14A	92-93		MCC 328-9	MEF 132-6	MES 337-8
RM	250	RJ14A	94-95		MCC 328-8	MEF 132-6	MES 337-8
RM	250	RJ17A	96		MCC 208-8	MEF 132-6	MES 308-7
RM	250	RJ18C	97-02		MCC 208-8	MEF 158-6	MES 308-7
RM	250	RJ18C	03-12		MCC 352-8	MEF 154-6	MES 308-7
RM-Z	250		04-13		MCC 339-8		MES 354-7
TS	250 X	SJ11B	84-87		MCC 303-6	MEF 134-6	
TS	250	TS2504	77-78		MCC 307-6	MEF 115-6	
TS	250 ER	TS250	79-81		MCC 307-6	MEF 106-6	
VL	250 Intruder	WVA5	00-07		MCC 304-5	MEF 121-5	
LT-F	300 F King Quad		99-02		MCC 336-8		
DR	350 S	SK42B	90-94		MCC 309-7	MEF 134-6	MES 337-6
DR	350 SE	SK42B	94-99		MCC 309-7	MEF 134-6	MES 337-6
GT	380	GT380	73-77		MCC 307-6	MEF 106-6	
DR	400 S	DR400	80-81		MCC 306-6	MEF 106-6	MES 337-6



Adjuster-/Ausgleichs-Kit falls erforderlich – if necessary
 Superkit siehe Seite 4.04 – see page 4.04
 Superkit* ohne Dichtung – without gasket

C (Competition) Hightech Reibmaterial – hightech friction
 PK (Powerkit) Reiblamellen + Stahlscheiben – frictionplates + steelplates
 RAC (Racing) High-Performance Kupplung – high-performance clutch



Suzuki

DR-Z	400	WVBC	00-06		MCC 445-8	MEF 150-6	MES 358-7
DR-Z	400 SM	WVB8	05-09		MCC 445-8	MEF 150-6	MES 358-7
GN	400 T,TD,L	GN400	80-81		MCC 306-6	MEF 106-6	MES 337-6
GS	400	GS400	77-78		MCC 308-6	MEF 106-6	
GS	400 E	GS400	78-79		MCC 308-6	MEF 106-6	
GSF	400 Bandit	GK75B	91-95		MCC 340-8	MEF 134-6	
GSX	400 F	GS40X	81		MCC 306-6	MEF 106-6	
GSX	400 E	GK53C	82-83		MCC 309-7	MEF 115-6	MES 337-6
GSX	400 E, L, S	GS40X	80-81		MCC 309-7	MEF 106-6	MES 337-6
GSX	400 F		89-		MCC 309-7	MEF 134-6	MES 337-6
GSX	400 L	GS40X	80-81		MCC 309-7	MEF 106-6	MES 337-6
GSX	400 S	GK53C	84-87		MCC 309-7	MEF 115-6	MES 337-6
GSXR	400		87-95		MCC 323-9	MEF 134-6	
LT-F	400 Eiger	AK	02-08		MCC 356-6	MEF 107-6	MES 358-5
LT-F	400 King Quad		08-12		MCC 356-6		MES 358-5
LT-Z	400 Quad Sport		03-04		MCC 445-8	MEF 150-6	MES 358-7
LT-Z	400		05-13		MCC 358-9		MES 358-8
RF	400		93-97		MCC 113-9	MEF 106-6	
GS	450	GS450	80-81		MCC 309-7	MEF 115-6	MES 337-6
GS	450 E,S	GL51C	84-88		MCC 309-7	MEF 115-6	MES 337-6
GS	450 L	GS450	80-81		MCC 309-7	MEF 115-6	MES 337-6
GS	450 L	GL51D	84-87		MCC 309-7	MEF 115-6	MES 337-6
GS	450 S	GL51C	84-88		MCC 309-7	MEF 106-6	MES 337-6
GS	450 T	GS450	80-81		MCC 309-7	MEF 115-6	MES 337-6
LT-R	450		06-12		MCC 352-8		MES 416-7
RM-X	450		10-12		MCC 357-8		MES 416-7
RM-Z	450		05-14		MCC 357-8		MES 416-7
DR	500 S	DR500	81-88		MCC 311-6		MES 301-6
GS	500 E,EU	GM51B	89-93		MCC 309-7	MEF 144-6	MES 337-6
GS	500 E,EU	GM51B	89-93	Superkit	MSK 217		
GS	500 E,EU	GM51B	94-02		MCC 309-7	MEF 144-6	MES 337-6
GS	500 E,EU	GM51B	94-02	Superkit	MSK 217		
GS	500 F	WVBK	03-07		MCC 309-7	MEF 144-6	MES 337-6
GS	500 F	WVBK	03-07	Superkit	MSK 217		
GS	500 E		78-79		MCC 310-7	MEF 115-6	MES 337-6
LT	500 R		87-91		MCC 328-8	MEF 134-6	MES 338-8
LT-F	500		98-02		MCC 356-6	MEF 107-6	MES 358-5
RG	500 Gamma	HM31A	85		MCC 310-7	MEF 107-6	MES 337-6
RG	500 Gamma	HM31A	86-89		MCC 337-9	MEF 112-4	
RM	500		84		MCC 312-8	MEF 115-6	MES 337-8
GS	550	GS550	77		MCC 310-7	MEF 106-6	
GS	550 E	GS550E	78-80		MCC 310-7	MEF 106-6	MES 337-6
GS	550 L	GS550E	80-		MCC 310-7	MEF 106-6	MES 337-6
GS	550 M	GS550M	81-82		MCC 310-7	MEF 106-6	MES 337-6
GS	550 T	GS550E	81		MCC 310-7	MEF 106-6	MES 337-6
GSX	550 E	GN71D	83-85		MCC 310-7	MEF 106-6	
DR	600 R,RU	SN41A	86-89		MCC 311-6	MEF 112-4	MES 301-6
DR	600 S,SU	SN41A	85-89		MCC 311-6	MEF 112-4	MES 301-6
GSF	600 Bandit	GN77B	94-04		MCC 312-8	MEF 145-4	MES 344-7
GSR	600	WVB9	06-10		MCC 110-8	MEF 152-6	MES 361-7
GSX	600 F	GN72B	88-91		MCC 312-8	MEF 126-4	MES 344-7
GSX	600 FU	GN72B	88-91		MCC 312-8	MEF 126-4	MES 344-7
GSX	600	GN72B	92-97		MCC 318-8	MEF 145-6	MES 341-9
GSX	600 F	WVAJ	98-01		MCC 314-8	MEF 145-4	MES 344-7
GSXR	600	AD	97-98		MCC 319-9		MES 414-9
GSXR	600	AD	99-00		MCC 319-9		MES 409-8
GSXR	600	WVBG	01-03		MCC 319-9		MES 408-8
GSXR	600	WVB2	04-05		MCC 319-9	MEF 152-6	MES 408-8
GSXR	600	WVCE	06-07		MCC 353-8	MEF 151-6	MES 356-7
GSXR	600	WVCV	08-10		MCC 354-9	MEF 151-6	MES 415-8
GSXR	600	C3	11-14		MCC 354-9		MES 415-8
RF	600 R	GN76B	93-97		MCC 338-7	MEF 145-6	
VS	600 GLP	VN51B	94-97		MCC 321-7	MEF 126-4	MES 301-6
DL	650 V-Strom	WVB1	04-11		MCC 115-7		MES 337-6
DL	650 A V-Strom	WVB1	12-14		MCC 115-7		MES 337-6
DR	650 SE	SP46B	96-99		MCC 320-8	MEF 126-4	MES 412-8



Suzuki

DR	650 R,RS,RE, RSE	SP44B	90-93		MCC 321-7	MEF 126-4	MES 301-6
DR	650 R,RS,RE, RSE	SP45B	94-96		MCC 321-7	MEF 126-4	MES 301-6
GR	650 X	GP51A	83-85		MCC 314-8	MEF 126-4	
GS	650 G	GS650G	81-82		MCC 316-8	MEF 106-6	MES 338-8
GSF	650 Bandit, S Bandit	WVB5	05-06		MCC 314-8		MES 344-7
GSF	650 Bandit, S Bandit	WVCJ	07-08		MCC 110-8		MES 417-7
GSF	650 Bandit, S Bandit	WVCZ	09-14		MCC 110-8		MES 417-7
GSX	650 F	WVCJ, WVCZ	08-14		MCC 110-8		MES 417-7
LS	650 Savage	NP41B	86-00		MCC 311-6	MEF 126-4	MES 301-6
SFV	650 Gladius	WVCX	09-14		MCC 360-7		MES 337-6
SV	650	AV111	99-02		MCC 321-7	MEF 151-6	MES 337-6
SV	650	WVBY	03-08		MCC 115-7		MES 337-6
XF	650 Freewind	AC	97-02		MCC 320-8	MEF 104-4	MES 412-8
DR	750 S,SU	SR41B	88-89		MCC 320-8	MEF 126-4	MES 412-8
GS	750	GS750D	77-79		MCC 316-8	MEF 106-6	MES 337-8
GS	750	GS750E	77-79		MCC 316-8	MEF 106-6	MES 337-8
GSR	750	C5	11-14		MCC 317-10	MEF 105-5	MES 413-9
GSX	750 E	GS75X	80-82		MCC 313-8	MEF 106-6	
GSX	750 ES	GR72A	83-		MCC 313-8	MEF 126-4	MES 338-8
GSX	750 L	GS75X	80-81		MCC 313-8	MEF 106-6	MES 338-8
GSX	750 S	GR71A	82-87		MCC 313-8	MEF 106-6	MES 338-8
GSX	750 F	AK	98-06		MCC 314-8	MEF 145-4	MES 344-7
GSX	750 EF	GR72A	85-		MCC 318-8	MEF 126-4	MES 338-8
GSX	750 F	G78A	89-97		MCC 318-8	MEF 112-4	MES 341-9
GSX	750	AE	98-01		MCC 342-8	MEF 145-4	MES 344-7
GSXR	750	GR75A	85-87		MCC 312-8	MEF 126-4	MES 344-7
GSXR	750	GR77B	88-89		MCC 318-8	MEF 112-4	MES 341-9
GSXR	750	GR7AB	90-91		MCC 318-8	MEF 145-6	MES 341-9
GSXR	750 W	GR7BB	92-95		MCC 318-8	MEF 145-6	MES 348-8
GSXR	750 W	GR7BB/DB	96-99		MCC 317-10		MES 414-9
GSXR	750 W	WVBD	00-03		MCC 317-10	MEF 152-6	MES 413-9
GSXR	750 W	WVBD	00-03	Superkit	MSK 213		
GSXR	750 W	WVB3	04-05		MCC 317-10	MEF 152-6	MES 413-9
GSXR	750 W	WVB3	04-05	Superkit	MSK 213		
GSXR	750	WVCF	06-07		MCC 354-9	MEF 151-6	MES 415-8
GSXR	750	WVCW	08-10		MCC 354-9	MEF 151-6	MES 415-8
GSXR	750	C4	11-14		MCC 354-9	MEF 151-6	MES 415-8
GT	750	GT750	73-77		MCC 316-8	MEF 106-6	MES 338-8
VS	750 Intruder GLF, GLP	VR51B	85-91		MCC 321-7	MEF 126-4	MES 301-6
DR	800 SU,S	SR42B	90-97		MCC 320-8	MEF 126-4	MES 412-8
DR	800 SU,S	SR43B	90-97		MCC 320-8	MEF 126-4	MES 412-8
M	800 Intruder	WVB4	05-13		MCC 321-7		MES 301-6
VL	800 Intruder LC Volusia	WVBM	01-06		MCC 321-7		MES 301-6
VS	800 GL	VS52B	92-00		MCC 321-7	MEF 126-4	MES 301-6
VX	800 U	VS51B	90-96		MCC 321-7		MES 301-6
VZ	800 Marauder	WVBM	97-09		MCC 321-7		MES 301-6
GS	850 G	GS72A	79-86		MCC 313-8	MEF 106-6	MES 338-8
RF	900 R	GT73B	94		MCC 341-11		MES 342-10
RF	900 R	GT73B	95-97		MCC 317-10	MEF 143-6	MES 414-9
DL	1000 V-Strom	WVBS	02-09		MCC 349-10	MEF 144-5	MES 410-9
GS	1000 G,GL	GS100G	80-81		MCC 323-9	MEF 106-6	MES 339-9
GSXR	1000	WVBL	01-02		MCC 343-10	MEF 105-5	MES 310-9
GSXR	1000	WVBL	01-02	Racingkit	MCC 343-10RAC	MEF 105-5	MES 310-9
GSXR	1000	WVBL	01-02	Superkit	MSK 214		
GSXR	1000	WVBZ	03-04		MCC 343-10	MEF 105-5	MES 310-9
GSXR	1000	WVBZ	03-04	Racingkit	MCC 343-10RAC	MEF 105-5	MES 310-9
GSXR	1000	WVBZ	03-04	Superkit	MSK 214		
GSXR	1000	WVB6	05-06		MCC 359-10		MES 369-9
GSXR	1000	WVB6	05-06	Adjuster-Kit			MES 901-2
GSXR	1000	WVCL	07-08		MCC 359-10		MES 370-9
GSXR	1000	WVCL	07-08	Adjuster-Kit			MES 902-2
GSXR	1000	WVCY	09-14		MCC 361-9		MES 362-8
SV	1000	WVBX	03-08		MCC 349-10		MES 410-9



Adjuster-/Ausgleichs-Kit falls erforderlich – if necessary
 Superkit siehe Seite 4.04 – see page 4.04
 Superkit* ohne Dichtung – without gasket

C (Competition) Hightech Reibmaterial – hightech friction
 PK (Powerkit) Reiblamellen + Stahlscheiben – frictionplates + steelplates
 RAC (Racing) High-Performance Kupplung – high-performance clutch



Suzuki

TL	1000 S	AG111	97-98		MCC 317-10	MEF 122-6	MES 414-9
TL	1000 S	AG111	99-00		MCC 344-9	MEF 122-6	
GS	1100 G	GU73A	84-85		MCC 323-9	MEF 115-6	MES 339-9
GS	1100 G	GU71A	86		MCC 323-9	MEF 115-6	MES 339-9
GSX	1100	GS100X	80-		MCC 323-9	MEF 115-6	
GSX	1100	GS100X	80-81		MCC 323-9	MEF 106-6	
GSX	1100	GS1100X	82-83		MCC 323-9	MEF 115-6	MES 339-9
GSX	1100 E	GS110X	81-		MCC 323-9	MEF 106-6	
GSX	1100 E,EF,ES	GV71C	84-86		MCC 323-9	MEF 106-6	MES 339-9
GSX	1100 F	GV72C	88-94		MCC 324-11	MEF 112-4	MES 342-10
GSX	1100 G	GV74A	91-94		MCC 326-10		MES 342-10
GSXR	1100	GV74CD	86-88		MCC 324-11	MEF 126-4	MES 342-10
GSXR	1100	GV73C	89-92		MCC 326-10		MES 342-10
GSXR	1100 W	GU75C	93-94		MCC 341-11		MES 342-10
GSXR	1100 W	GU75C	95-97		MCC 341-11		MES 342-10
GSF	1200 Bandit, S Bandit	GV75A	96-00		MCC 317-10		MES 414-9
GSF	1200 Bandit, S Bandit	WVA9	00		MCC 317-10		MES 414-9
GSF	1200 Bandit, S Bandit	WVA9	01-05		MCC 348-10		MES 414-9
GSF	1200 Bandit	WVCB	06		MCC 348-10		MES 414-9
GSX	1200 FS	A3	99-00		MCC 317-10		MES 414-9
GSF	1250 Bandit, S Bandit	WVCH	07-12		MCC 355-9		MES 328-8
GSX	1250	WVCH	10-14		MCC 355-9		MES 328-8
GSX	1300 B-King	WVCR	08-12		MCC 349-10		MES 410-9
GSX	1300 R Hayabusa	A1	99-01		MCC 322-10	MEF 153-6	MES 410-9
GSX	1300 R Hayabusa	WVCK	02-08		MCC 349-10	MEF 153-6	MES 410-9
GSX	1300 R Hayabusa	WVCK	09-12		MCC 349-10		MES 410-9
GSX	1300 RA Hayabusa	WVCK	13-		MCC 349-10		MES 410-9
GSX	1400	WVBN	01-07		MCC 350-10		
VS	1400 Intruder	VX51L/LD	88-03		MCC 327-10		MES 344-9
M	1500		09-12		MCC 355-9		
VL	1500 C 1500 Intruder	WVAL	98-03		MCC 323-9	MEF 131-5	MES 340-8
VL	1500 C 1500 Intruder	WVAL	98-03	Superkit	MSK 212		
VL	1500 C 1500 Intruder	WVCU	98-09		MCC 323-9	MEF 131-5	MES 340-8
VL	1500 C 1500 Intruder	WVCU	98-09	Superkit	MSK 212		
VL	1500 C 1500 T Intruder	C1	13-		MCC 355-9		MES 328-8
VZ	1600 Marauder		04-05		MCC 230-8		
VLR	1800 C Intruder	WVCA	08-13		Anfrage	MEF 152-6	
VZR	1800 M 1800 R Intruder	WVCA	06-13		Anfrage		

TM

	250 Enduro		96-00		MCC 525-9		
EN	250 ,F		01-07		MCC 525-9		
MX	250 , F		01-07		MCC 525-9		
SMR	250		02-07		MCC 525-9		
SMX	250		02-06		MCC 525-9		
	250 Cross		96-00		MCC 525-9		
	300 Enduro		96-00		MCC 525-9		
EN	300		01-07		MCC 525-9		
SMR	300		03-06		MCC 525-9		
	300 Cross		96-05		MCC 525-9		
EN	400		02-03		MCC 525-9		

Triumph

TT	600		00-03		MCC 319-9		
	600 Speed Four	bis FG 210261	02-05		MCC 319-9		
	600 Speed Four	FG-Nr 210262-	02-05		MCC 118-7	MEF 115-6	
	600 Daytona	806LW	03-04		MCC 319-9		
	650 Daytona	865LX	05		MCC 118-7	MEF 115-6	
	675 Daytona	D67LC	06-12		MCC 319-9		
	675 Street Triple		07-11		MCC 319-9		
	750 Daytona	T300D	91-96		MCC 140-9	MEF 121-5	
	800 America		02-04		MCC 160-7		
	800 Bonneville	MotorNr 211133-			MCC 160-7	MEF 115-6	
	800 Bonneville T 100	MotorNr 211133-			MCC 160-7	MEF 115-6	
	800 Speedmaster	908ML	03-04		MCC 160-7	MEF 115-6	
	865 America	986MK	05-08		MCC 160-7		
	865 Speedmaster	908ML	05-08		MCC 160-7	MEF 115-6	



Triumph

900 Adventurer	T309	96-01		MCC 140-9	MEF 121-5
900 Daytona Super III	T300B	94-		MCC 140-9	MEF 121-5
900 Thruxton	986ME	04-12		MCC 160-7	MEF 115-6
900 Legend	T309RT	99-01		MCC 140-9	MEF 121-5
865 Scrambler	986MG	05-11		MCC 160-7	MEF 115-6
900 Speedmaster		05-08		MCC 160-7	MEF 115-6
900 Thunderbird Sport	T309RD	98-00		MCC 140-9	MEF 121-5
900 Thunderbird	T309RT	95-03		MCC 140-9	MEF 121-5
900 Tiger	T400	93-98		MCC 140-9	MEF 121-5
900 Trident	T300C	91-96		MCC 140-9	MEF 121-5
900 Trophy	T300E	91-96		MCC 140-9	MEF 121-5
900 Tiger	FG-Nr 71699-			MCC 129-9	MEF 129-5
900 Speed Triple	T300B	94-96		MCC 140-9	MEF 121-5
900 Speed Triple	T 509	97-98		MCC 140-9	MEF 121-5
900 Sprint	T300A	94-98		MCC 140-9	MEF 121-5
955 Daytona	T595	96-01		MCC 129-9	MEF 129-5
955 Daytona	595N	02-06		MCC 129-9	MEF 129-5
955 Speed Triple	T509	99-01		MCC 129-9	MEF 129-5
955 Speed Triple		02-04		MCC 162-10	MEF 129-5
955 Sprint ST	T695	99-01		MCC 129-9	MEF 129-5
955 Sprint RS		99-04		MCC 129-9	MEF 129-5
955 Tiger	709EN	01-06		MCC 129-9	MEF 129-5
1000 Daytona	T300	91-96		MCC 140-9	
1050 Speed Triple	515NJ	05-08		MCC 162-10	MEF 129-5
1050 Sprint ST	215NA	05-09		MCC 162-10	MEF 129-5
1050 Tiger	115NG	07-12		MCC 162-10	MEF 129-5

Vor

EN	400		99-02		MCC 530-7
EN	400		99-02	Competition	MCC 530-7C
EN	450		03-05		MCC 530-7
EN	450		03-05	Competition	MCC 530-7C
MX	450		03-05		MCC 530-7
MX	450		03-05	Competition	MCC 530-7C
SM	450		02-05		MCC 530-7
SM	450		02-05	Competition	MCC 530-7C
EN	500		99-02		MCC 530-7
EN	500		99-02	Competition	MCC 530-7C
SM	500		99-02		MCC 530-7
SM	500		99-02	Competition	MCC 530-7C
EN	530		02-05		MCC 530-7
EN	530		02-05	Competition	MCC 530-7C
MX	530		02-05		MCC 530-7
MX	530		02-05	Competition	MCC 530-7C
SM	530		02-05		MCC 530-7
SM	530		02-05	Competition	MCC 530-7C
SM	570		03-05		MCC 530-7
SM	570		03-05	Competition	MCC 530-7C

Yamaha

DT	50 M	2M4	80-95		MCC 400-2	MEF 142-5
DT	50 MX	13N	82-		MCC 400-2	MEF 142-5
DT	50 MX	1NN	86-		MCC 400-2	MEF 142-5
DT	50 R	3MN	89-96		MCC 400-2	MEF 101-6
DT	50 R		97-08		MCC 550-4	
DT	50 X Supermotard		04-08		MCC 550-4	
DT	50 LC		90-		MCC 402-4	MEF 101-6
FS1	50 DX	1Y2	75-78		MCC 400-2	MEF 101-6
FS1	50 DX	3F2	79-80		MCC 400-2	MEF 101-6
FS1	50 G	1K4	76		MCC 400-2	MEF 101-6
RD	50 M	2E0,2L4	79-82		MCC 400-2	MEF 142-5
RD	50	2U1	78		MCC 401-3	MEF 101-6
RD	50 DX		75-82		MCC 401-3	



Adjuster-/Ausgleichs-Kit falls erforderlich – if necessary
 Superkit siehe Seite 4.04 – see page 4.04
 Superkit* ohne Dichtung – without gasket

C (Competition) Hightech Reibmaterial – hightech friction
 PK (Powerkit) Reiblamellen + Stahlscheiben – frictionplates + steelplates
 RAC (Racing) High-Performance Kupplung – high-performance clutch



Yamaha

TY	50 M	1G3,2J8	80		MCC 400-2	MEF 142-5	
TZR	50		04-14		MCC 550-4		
YZ	50		80-83		MCC 401-3	MEF 142-5	
DT	80 MX	5J1	81-83		MCC 401-3	MEF 101-6	
DT	80 LC1	37A	83-86		MCC 402-4		
DT	80 MXS	5T8	84		MCC 402-4	MEF 142-5	
DT	80 LC2	53V	87-96		MCC 403-5	MEF 142-5	MES 317-4
FS	80 SE	5A7	81		MCC 401-3		
RD	80 MX	5G1	81-		MCC 401-3	MEF 101-6	
RD	80 LC1	10X	82-86		MCC 402-4	MEF 142-5	
RD	80 LC2	30W	82-86		MCC 402-4	MEF 142-5	
RX	80 SE	12N	82-		MCC 401-3	MEF 101-6	
YZ	80		76-80		MCC 402-4	MEF 142-5	
YZ	80		81-85		MCC 403-5	MEF 142-5	MES 317-4
YZ	80		86-92		MCC 429-6	MEF 142-5	MES 363-5
YZ	80		93-94		MCC 429-6	MEF 142-5	MES 363-5
YZ	80	4LB	95-01		MCC 439-7	MEF 142-5	
YZ	85	CB04	02-14		MCC 439-7	MEF 142-5	MES 320-6
DT	125 LC	10V	85-91		MCC 428-6	MEF 142-5	MES 317-6
DT	125 Tenere		89-96		MCC 428-6	MEF 101-6	MES 317-6
DT	125	3RM,4B2	88-91		MCC 429-6	MEF 142-5	
DT	125 R,RE,X	4BL,3RM	92-07		MCC 439-7	MEF 142-5	MES 317-6
DTZ	125 Tenere		88-91		MCC 428-6	MEF 101-6	
RD	125 LC	10W	82-		MCC 404-6	MEF 142-5	MES 317-6
SR	125	3MW8	96-03		MCC 433-4	MEF 119-4	MES 313-3
TDR	125	4GW1	90-03		MCC 439-7	MEF 142-5	MES 317-6
TT-R	125		00-13		MCC 403-5	MEF 142-5	MES 317-4
TT-R	125		00-13	Superkit	MSK 215		
TW	125 Trailway	DE01	99-04		MCC 433-4	MEF 102-6	MES 313-3
TZ	125	CE04	99-03				MES 363-5
TZR	125		87-97		MCC 429-6	MEF 142-5	MES 317-6
WR	125 R, X	DE07	09-14		MCC 462-5	MEF 124-4	
XT	125 R	74	05-07		MCC 403-5	MEF 142-5	MES 317-4
XT	125 R	74	05-07	Superkit	MSK 215		
XT	125 R (4 plates)		07-11		MCC 102-4	MEF 142-5	
XT	125 X	74	05-07		MCC 403-5	MEF 142-5	MES 317-4
XT	125 X	74	05-07	Superkit	MSK 215		
XT	125 X (4 plates)		07-11		MCC 102-4	MEF 142-5	
XV	125 Virago	5AJ	97-02		MCC 409-5	MEF 102-4	MES 315-4
XVS	125 Drag Star	VW01	00-03		MCC 444-6	MEF 102-4	MES 315-4
YBR	125 (4 plates)		05-14		MCC 102-4		MES 331-4
YBR	125 (5 plates)		06-08		MCC 403-5	MEF 142-5	MES 331-4
YBR	125 (5 plates)		06-08	Superkit	MSK 216		
YBR	125 Custom (4 plates)		08-13		MCC 102-4		MES 331-4
YBR	125 Custom (5 plates)		08-13		MCC 403-5	MEF 142-5	MES 331-4
YBR	125 Custom (5 plates)		08-13	Superkit	MSK 216		
YZ	125	2HG	87-88		MCC 430-6	MEF 102-6	MES 364-6
YZ	125		89-90		MCC 431-7	MEF 102-6	MES 364-6
YZ	125	4PE	91-92		MCC 432-7	MEF 124-6	MES 321-7
YZ	125	4PE	93-95		MCC 443-8	MEF 124-6	MES 321-7
YZ	125	4PE,4XM	96-99		MCC 443-8	MEF 124-6	MES 321-7
YZ	125	CE10	00-15		MCC 449-8	MEF 114-6	MES 321-7
YZF	125	RE06	08-14		MCC 462-5	MEF 124-4	
DT	175 MX	2K4,2X2,4J	79-81		MCC 405-6	MEF 142-5	
YFS	200 Blaster		88-06		MCC 439-7	MEF 142-5	MES 317-6
DT	250 MX	1R7,4E7	77-82		MCC 407-7	MEF 102-6	
RD	250		75-79		MCC 406-7	MEF 102-6	MES 318-7
RD	250 LC	4L1	80-82		MCC 406-7	MEF 102-6	MES 318-7
RD	250 S		77		MCC 406-7		
SR	250 SE	3Y8	81-89		MCC 408-5	MEF 101-6	
SRX	250		89-		MCC 408-5		MES 315-4
TT	250 R		93-00		MCC 443-7		MES 321-6
WR	250	CG	01-03		MCC 423-8	MEF 114-6	MES 323-7
WR	250 F	CG	01-14		MCC 455-9	MEF 102-6	MES 323-8
WR	250 R		08-15		MCC 443-7	MEF 162-6	MES 321-6
WR	250 X		10-14		MCC 443-7	MEF 162-6	MES 321-6



Yamaha

XS	250 SF	1U5	78-81		MCC 407-7	MEF 101-6	MES 314-7
XT	250	3Y3,4Y1	80-90		MCC 410-6	MEF 101-6	
XTZ	250 Lander (Brasil)		07-09		MCC 108-6		
XV	250 Virago	3LS,3LW	89-99		MCC 409-5	MEF 102-4	MES 315-4
XVS	250	VG03	01-04		MCC 409-5	MEF 102-4	MES 315-4
YBR	250		07-11		MCC 108-6		MES 336-5
YFB	250		92-97		MCC 403-5	MEF 102-6	MES 317-4
YFM	250 Bear Tracker		99-04		MCC 403-5		MES 363-5
YFM	250 Big Bear		07-10		MCC 403-5		MES 363-5
YFM	250 Bruin		05-07		MCC 403-5		MES 363-5
YFM	250 Raptor	AG03/06	08-		MCC 443-6		MES 321-5
YS	250 Fazer (Brasil)		06-08		MCC 108-6		
YZ	250		82-84		MCC 434-7	MEF 102-6	MES 325-6
YZ	250		85-87		MCC 434-7	MEF 124-6	MES 325-6
YZ	250		88-92		MCC 435-7	MEF 124-6	MES 352-6
YZ	250		93-99		MCC 423-8	MEF 124-6	MES 359-7
YZ	250	4XL	00-15		MCC 423-8	MEF 156-6	MES 359-7
YZ	250 F	CG	01-15		MCC 455-9		MES 323-8
YZF	300 R3		15-		MCC 145-7		
RD	350	521	73-79		MCC 406-7	MEF 102-6	MES 318-7
RD	350 LC	4L0	81-82		MCC 406-7	MEF 102-6	MES 318-7
RD	350 LC, YPVS	31K, 31W	83-84		MCC 406-7	MEF 102-6	MES 318-7
RD	350 LC, LCF	1WW, WX	85-94		MCC 406-7	MEF 102-6	MES 318-7
XT	350	55V, 59Y	85-95		MCC 406-7	MEF 114-6	MES 407-6
YFM	350 ER		92-95		MCC 620-7		MES 373-6
YFM	350 Big Bear		87-98		MCC 620-7		
YFM	350 Raptor		04-10		MCC 620-7		MES 373-6
YFM	350 Warrior		87-		MCC 620-7		
YFM	350 Wolvrine		95-04		MCC 620-7	MEF 124-6	
YFZ	350 Banshee		87-06		MCC 406-7	MEF 102-6	MES 318-7
DT	400 MX	1R6, 513	77-79		MCC 407-7	MEF 102-6	
FZR	400		88-89		MCC 436-8	MEF 142-5	MES 320-8
FZR	400 RR		91-94		MCC 436-8	MEF 142-5	MES 320-8
RD	400 S	1A3	76-79		MCC 406-7	MEF 102-6	
SR	400		14-		MCC 412-8	MEF 114-6	MES 318-7
SRX	400		90-96		MCC 416-8	MEF 162-6	
XJR	400		93-99		MCC 419-8	MEF 162-6	
WR	400 F	CH04	00-		MCC 423-8	MEF 155-6	MES 318-7
XS	400	2AE	78-82		MCC 407-7	MEF 102-6	MES 325-6
XS	400 SE	4G5	80-82		MCC 407-7	MEF 102-6	
XS	400 DOHC	12F, 12E	82-87		MCC 411-5	MEF 102-6	
YFM	400 Big Bear		01-04		MCC 620-7	MEF 155-6	
YFM	400 Kodiak		93-99		MCC 620-7	MEF 155-6	
YZ	400 F		98-99		MCC 415-8		MES 318-7
WR	426	CJ02	01-02		MCC 450-9	MEF 156-6	MES 365-8
YZ	426	CJ01	01-02		MCC 450-9	MEF 156-6	MES 365-8
YFZ	450		04-10		MCC 458-8	MEF 117-6	MES 359-7
WR	450	CJ04	03-04		MCC 450-9	MEF 156-6	MES 365-8
WR	450 F	CJ04	05-14		MCC 423-8	MEF 117-6	MES 316-8
YZ	450 F		03-07		MCC 457-9	MEF 156-6	MES 365-8
YZ	450 FW		07-15		MCC 423-8	MEF 137-6	MES 316-8
YZ	465	3R5, 4V4	80-81		MCC 407-7	MEF 102-6	MES 325-6
YZ	490	23X	82-87		MCC 434-7	MEF 102-6	MES 314-7
YZ	490		88-91		MCC 435-7		MES 314-7
RD	500 LC	47X, 1GE	84-86		MCC 437-7	MEF 114-6	
SR	500	48T, 3EB	78-95		MCC 412-8	MEF 114-6	MES 318-7
XT	500	1U6	77-89		MCC 412-8	MEF 114-6	MES 318-7
XV	500	26R	83-		MCC 413-6	MEF 111-5	
XV	535 SE, N, H	3BR, 2YL	87-02		MCC 413-6	MEF 158-6	MES 404-6
XJ	550	4V8	81-83		MCC 414-8	MEF 114-6	MES 325-7
XT	550	5Y3	82		MCC 415-8	MEF 114-6	MES 318-7
XT	550	5Y3	83		MCC 416-8	MEF 114-6	MES 318-7
XT	550	5Y3	83	Superkit	MSK 201		



Adjuster-/Ausgleichs-Kit falls erforderlich – if necessary
 Superkit siehe Seite 4.04 – see page 4.04
 Superkit* ohne Dichtung – without gasket

C (Competition) Hightech Reibmaterial – hightech friction
 PK (Powerkit) Reiblamellen + Stahlscheiben – frictionplates + steelplates
 RAC (Racing) High-Performance Kupplung – high-performance clutch

**Yamaha**

XZ	550	11U,11V	83-		MCC 412-8	MEF 114-6	MES 325-7
FJ	600		-84		MCC 419-8		
FZ	600		86-87		MCC 419-8	MEF 114-6	MES 325-7
FZ6	600 , S Fazer	RJ07/RJ14	04-09		MCC 419-8	MEF 117-6	MES 315-7
FZ6	600 , S Fazer	RJ07/RJ14	04-09	Superkit	MSK 203		
FZ6	600 S2	RJ07/RJ14	07-09		MCC 419-8	MEF 117-6	MES 315-7
FZ6	600 S2	RJ07/RJ14	07-09	Superkit	MSK 203		
FZ6	600		09-10		MCC 414-8	MEF 117-6	MES 315-7
FZR	600 H,M,N	3HE, 3RG	89-93		MCC 420-9	MEF 142-5	MES 320-8
FZR	600 R	4JH,4MH	94-95		MCC 441-9	MEF 114-6	MES 320-8
FZS	600 Fazer	RJ02	98-99		MCC 425-9	MEF 102-6	MES 366-8
FZS	600 Fazer	RJ02	00-03		MCC 451-9	MEF 162-6	MES 366-8
FZS	600 SP	RJ02	00-		MCC 451-9	MEF 162-6	MES 366-8
SRX	600 H,N	1XL,1XM	86-90		MCC 416-8	MEF 114-6	MES 318-7
SRX	600 H,N	1XL,1XM	86-90	Superkit	MSK 201		
TT	600	59X,2AG,2J	85-93		MCC 416-8	MEF 102-6	MES 318-7
TT	600	59X,2AG,2J	85-93	Superkit	MSK 204		
TT	600	4LW	94-03		MCC 416-8	MEF 102-6	MES 318-7
TT	600	4LW	94-03	Superkit	MSK 204		
TT	600 RE	DJ01	04-		MCC 416-8	MEF 102-6	MES 318-7
TT	600 RE	DJ01	04-	Superkit	MSK 204		
XJ	600	51J, 3KM, 3KN	84-90		MCC 419-8	MEF 114-6	MES 401-8
XJ	600	4BR, 4LX,RJ01	94-03		MCC 419-8	MEF 114-6	MES 401-8
XJ	600	4BR, 4LX,RJ01	94-03	Superkit	MSK 200		
XJ	600 Diversion	4BR, 4LX,RJ01	91-97		MCC 419-8	MEF 114-6	MES 401-8
XJ	600 Diversion	4BR, 4LX,RJ01	91-97	Superkit	MSK 200		
XJ6	600 F,N,S	RJ19	09-14		MCC 414-8	MEF 117-6	MES 315-7
XT	600 E	3TB,3UW	90-03		MCC 416-8	MEF 114-6	MES 318-7
XT	600 E	3TB,3UW	90-03	Superkit	MSK 201		
XT	600 H,N		86-89		MCC 416-8	MEF 114-6	MES 318-7
XT	600 H,N		86-89	Superkit	MSK 201		
XT	600 Z	1VJ	83-85		MCC 416-8	MEF 102-6	MES 318-7
XT	600 Z	1VJ	83-85	Superkit	MSK 204		
XT	600 Z	1VJ	86-87		MCC 416-8	MEF 102-6	MES 318-7
XT	600 Z	1VJ	86-87	Superkit	MSK 204		
XT	600 Z	3AJ	88-00		MCC 416-8	MEF 114-6	MES 318-7
XT	600 Z	3AJ	88-00	Superkit	MSK 201		
YZF	600 R6	RJ03	99-02		MCC 419-8	MEF 117-6	MES 403-8
YZF	600 R6	RJ05,RJ09	03-05		MCC 419-8	MEF 156-6	MES 403-8
YZF	600 R6	RJ11,RJ15	06-14		MCC 442-9		MES 315-8
YZF	600 R6S	RJ11	07-		MCC 419-8	MEF 157-6	MES 315-7
YZF	600 Thunder Cat	4TV	96-03		MCC 441-9	MEF 162-6	MES 366-8
XJ	650	4K0	80-83		MCC 419-8	MEF 162-6	MES 325-7
XJ	650 Turbo	11T	82-		MCC 419-8	MEF 114-6	MES 325-7
XS	650	3L1,4G7	80-81		MCC 421-6	MEF 114-6	
XS	650 SE	3L1, 4G7	79-81		MCC 421-6	MEF 114-6	
XS	650	3L1,4G7	82		MCC 437-7	MEF 114-6	
XVS	650 Drag Star	4VR/XR,VM02/03/04	97-07		MCC 435-7	MEF 158-6	MES 404-7
MT-03	660	RM02	06-12		MCC 456-7		MES 352-6
SZR	660	4SU	96-97		MCC 416-8	MEF 114-6	MES 318-7
SZR	660	4SU	96-97	Superkit	MSK 201		
XT	660 R,X	DM01	04-14		MCC 456-7		MES 352-6
XTZ	660 Tenere	4MY3	91-96		MCC 416-8	MEF 114-6	MES 318-7
XTZ	660 Tenere	4MY3	91-96	Superkit	MSK 201		
XT	660 Z, Tenere		08-12		MCC 456-7		MES 352-6
YFM	660 Raptor	AM01	01-06		MCC 416-8	MEF 114-6	MES 318-7
YFM	700 Raptor		06-14		MCC 458-8	MEF 137-6	MES 359-7
FZ	750	2KK	87-90		MCC 414-8	MEF 117-6	MES 403-8
FZ	750	1FN,1TV	85-86		MCC 419-8	MEF 117-6	MES 403-8
FZR	750 R	3CU	87-88		MCC 422-9	MEF 117-6	MES 315-8
FZR	750 R (OW01)	3PJ	89-		MCC 442-9	MEF 117-6	MES 315-8
FZX	750 Fazer	2JE	87-89		MCC 414-8	MEF 117-6	MES 403-8
XJ	750	41Y	84-89		MCC 419-8	MEF 114-6	MES 315-7
XJ	750 Seca	11M	82-83		MCC 419-8	MEF 114-6	MES 315-7
XS	750 SE	1T5,3L3	77-81		MCC 407-7	MEF 114-6	
XTZ	750 H,N	3LD/3WM	89-95		MCC 419-8	MEF 117-6	MES 403-8



Yamaha

XV	750 SE	5G5	81-83		MCC 423-8	MEF 124-6	MES 405-8
XV	750 Virago	4PW	92-97		MCC 423-8	MEF 162-6	MES 405-8
YZF	750 R, SP	4HN, 4HT	93-97		MCC 442-9	MEF 117-6	MES 315-8
YZF	750 R 7		99-00		MCC 463-9		MES 316-8
FZ8	800		11-14		MCC 458-8		MES 405-7
MT-09	850		14-		MCC 457-9		MES 372-8
TDM	850 H,N	3VD, 4CM	91-95		MCC 419-8	MEF 117-6	MES 403-8
TDM	850	4TX	96-98		MCC 442-9	MEF 117-6	MES 315-8
TDM	850	4TX	99-01		MCC 442-9	MEF 156-6	MES 315-8
TRX	850	4UN	96-98		MCC 442-9	MEF 117-6	MES 315-8
XS	850		81-		MCC 424-7	MEF 114-6	MES 402-6
TDM	900	RN08,RN11	02-04		MCC 442-9	MEF 137-6	MES 315-8
TDM	900	RN08,RN11	02-04	Superkit	MSK 222		
TDM	900	RN14	05-14		MCC 442-9	MEF 137-6	MES 315-8
TDM	900	RN14	05-14	Superkit	MSK 222		
XJ	900	31A,	83-90		MCC 419-8		MES 315-7
XJ	900 F	58L,4BB	86-94		MCC 419-8	MEF 117-6	MES 315-7
XJ	900 S, Diversion	4KM	94-03		MCC 419-8	MEF 117-6	MES 403-8
XVS	950 A, R		09-14		MCC 461-9		MES 319-8
FZ1	1000	RN16	06-14		MCC 450-9		MES 372-8
FZR	1000	2LA	87-88		MCC 422-9	MEF 117-6	MES 315-8
FZR	1000 R, Exup	3LE	89-95		MCC 422-9	MEF 137-6	MES 315-8
FZS	1000	RN06,RN14	01-05		MCC 452-9	MEF 137-6	MES 315-8
GTS	1000 A	4BH	93-97		MCC 422-9	MEF 137-6	MES 315-8
XV	1000 SE	23W	83-86		MCC 423-8	MEF 114-6	MES 405-8
XV	1000 TR1	5A8	81-82		MCC 423-8	MEF 114-6	MES 405-8
XV	1000 Virago	2AE	88-		MCC 423-8	MEF 114-6	MES 405-8
YZF	1000 Thunder Ace	4VD	96-02		MCC 422-9	MEF 137-6	MES 315-8
YZF	1000 R1	RN01	98		MCC 437-7		MES 406-6
YZF	1000 R1	RN01,RN04	99-02		MCC 440-8		MES 319-7
YZF	1000 R1	RN09	03		MCC 440-8		MES 319-7
YZF	1000 R1	RN12, RN19	04-06		MCC 450-9		MES 372-8
YZF	1000 R1		07-08		MCC 450-9		MES 372-8
YZF	1000 R1		07-08	Adjuster-Kit			MES 900-2
YZF	1000 R1	RN22	09-14		MCC 457-9		
BT	1100 Bulldog	RP05	02-06		MCC 423-8		MES 405-8
FJ	1100	47E	84-87		MCC 438-8		MES 319-7
XS	1100 SE	3LP1-3	89-		MCC 423-8		
XS	1100	2H9,3X0	78-81		MCC 426-8	MEF 114-6	
XV	1100 Virago	3LP	89-99		MCC 423-8		MES 405-8
XVS	1100 Drag Star	VP05	99-07		MCC 423-8		MES 405-8
FJ	1200	3YA	86-95		MCC 438-8		MES 319-7
VMX	1200 V-Max		89-04		MCC 446-8		MES 322-8
XJR	1200	4PU	95-98		MCC 438-8		MES 319-7
XT	1200 Z, Super Tenere	DP01	10-14		MCC 454-9		MES 319-8
FJR	1300	RP04/RP08	01-14		MCC 454-9		MES 319-8
XJR	1300	RP02,RP06	99-03		MCC 438-8		MES 319-7
XJR	1300	RP10	04-14		MCC 438-8		MES 319-7
XVS	1300 Midnight Star	VP26	07-14		MCC 454-9		MES 319-8
XVZ	1300 Royal Star	4YP	96-02		MCC 446-8		MES 322-8
XV	1600 Wild Star	VP08	99-04		MCC 447-9		MES 322-8
MT-01	1670	RP12	05-10		MCC 459-10		MES 319-9
XV	1700 Road Star Warrior		03-05		MCC 447-9		MES 322-8
XV	1700 V-Max		09-14		MCC 426-10		MES 319-9
XV	1700 V-Max		09-14	Adjuster-Kit			MES 904-2
XV	1900 Midnight Star	VP23	06-12		MCC 460-11		MES 319-10



Adjuster-/Ausgleichs-Kit falls erforderlich – if necessary
 Superkit siehe Seite 4.04 – see page 4.04
 Superkit* ohne Dichtung – without gasket

C (Competition) Hightech Reibmaterial – hightech friction
 PK (Powerkit) Reiblamellen + Stahlscheiben – frictionplates + steelplates
 RAC (Racing) High-Performance Kupplung – high-performance clutch

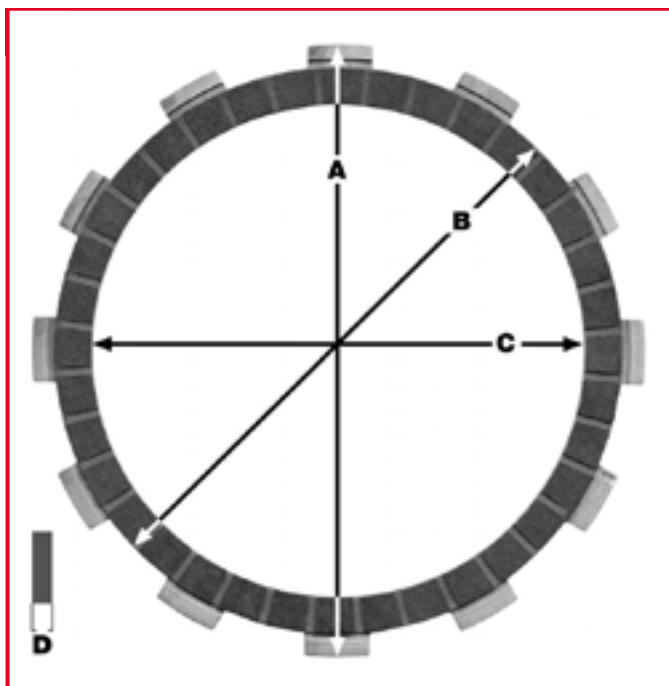

Lucas Nr.	NO.	A	B	C	D
MCC 100-3	3	119	110	91	3
MCC 101-3	2	95.3		74.3	3.5
	1	95.3		74.3	3.5
MCC 102-4	4	119	110	91	3
MCC 103-5	5	119	110	91	3
MCC 104-5	5	136	125	102	3
MCC 105-7	6	136	125	102	2.7
	1	136	125	108	3
MCC 106-5	4	136	125	102	2.7
	1	136	125	108	3
MCC 107-6	6	136	125	102	3
MCC 108-6	5	136	125	102	3
	1	136	125	108	3
MCC 109-8	8	150	139	121	2.7
MCC 110-8	7	136	125	102	3
	1	136	125	108	3
MCC 111-7	6	150	139	121	2.7
	1	152	138	121	3.5
MCC 112-6	6	136	125	102	2.7
MCC 112-7	7	136	125	102	2.7
MCC 113-9	8	119	110	91	3
	1	119	110	100	3.7
MCC 114-6	5	136	125	101	2.7
	1	136	125	108	3
MCC 115-7	6	150	139	117	3
	1	150	139	122	3
MCC 116-7	7	150	139	117	3
MCC 117-6	5	150	139	121	3.25
	1	150	139	121	3.6
MCC 118-7	6	136	125	102	3
	1	136	125	108	3
MCC 119-8	7	150	139	121	2.7
	1	152	138	121	3.5

Lucas Nr.	NO.	A	B	C	D
MCC 120-8	7	136	125	101	2.7
	1	136	125	108	3
MCC 121-8	8	161	151	129	3.8
MCC 122-6	6	150	139	119	3.8
MCC 123-7	7	150	139	121	3.8
MCC 124-9	8	136	125	102	3
	1	136	125	108	3
MCC 125-10	10	136	125	102	3
MCC 126-10	10	150	139	119	3.8
MCC 127-9	8	150	139	119	3.8
	1	150	139	119	3.6
MCC 128-8	7	150	139	119	3.8
	1	152	138	121	3.5
MCC 129-9	9	150	139	119	3.8
MCC 131-6	6	150	139	121	3.6
MCC 133-8	8	136	125	102	3
MCC 134-6	6	119	110	91	3
MCC 135-5	5	150	139	121	2.7
MCC 136-7	6	150	139	121	2.7
	1	150	139	119	3.8
MCC 138-8	8	150	139	117	3
MCC 139-6	6	150	139	121	3.25
MCC 140-9	9	161	151	129	3.8
MCC 141-8	8	151	139	119	3.8
MCC 142-10	8	150	139	119	3.8
	2	150	139	119	3.6
MCC 143-10	10	119	110	91	3
MCC 145-7	7	136	125	102	3
MCC 146-5	5	119	110	91	3
MCC 147-10	9	161	151	129	3.8
	1	161	151	129	3.8
MCC 148-7	5	150	139	121	3.25
	2	150	139	121	3.6
MCC 149-10	9	136	125	102	2.7
MCC 150-5	4	136	125	102	3
	1	136	125	108	3
MCC 151-7	6	161	151	129	3.8
	1	161	151	135.5	3.8
MCC 152-10	8	150	139	121	3.8
	2	150	139	121	3.5
MCC 152-8	8	136	125	102	3
MCC 153-9	7	136	125	102	3
	2	136	125	108	3
MCC 154-7	6	150	139	121	3.3
	1	150	139	122.7	3
MCC 155-8	8	150	139	117	3
MCC 156-5	4	119	110	91	3
	1	119	110	91	3
MCC 157-8	7	136	125	102	3
	1	136	125	108	3
MCC 158-8	6	150	139	117	3.3
	2	150	139	119	3.8



Lucas Nr.	NO.	A	B	C	D
MCC 159-5	4	119	110	91	3
	1	119	110	91	3
MCC 160-7	7	150	139	121	3.2
MCC 161-9	8	150	139	117	3.3
	1	150	139	121	3.8
MCC 162-8	7	150	139	116	3
	1	150	139	123	3.3
MCC 162-10	8	151	139	112	3.3
	2	151	139.7	119	3.8
MCC 163-4	4	115.5	109.7	91	2.6
MCC 200-5	5	125	114	93	3
MCC 201-6	6	125	114	93	3
MCC 204-7	7	150	139	117	3
MCC 205-7	7	158	146	123	3
MCC 206-6	6	158	146	127	3
MCC 207-7	7	161	151	129	3.8
MCC 208-8	8	158	146	123	3
MCC 209-7	7	161	151	129	3
MCC 210-8	8	134	120	100	3
MCC 211-9	9	158	146	123	3
MCC 212-9	9	161	151	129	3
MCC 213-10	10	144	132	112.5	3
MCC 214-7	7	134	120	100	3
MCC 215-8	8	161	151	129	3.8
MCC 216-5	5	158	146	123	3
MCC 217-8	8	150	139	117	3
MCC 218-5	5	144	132	112.5	3
MCC 219-7	7	144	132	112.5	3
MCC 220-6	6	144	132	112.5	3
MCC 221-9	9	144	132	112.5	3
MCC 222-6	5	119	110	91	3
	1	119	110	100	3
MCC 223-5	5	107.5	98.5	77	3.1
MCC 224-7	5	144	132	112.5	3
	2	144	132	112.5	3
MCC 225-12	12	150	139	121	3.25
MCC 226-5	4	136	125	102	3
	1	136	125	102	3
MCC 227-7	7	125	114	93	3
MCC 228-7	6	152	138	116	3
	1	152	138	121	3.5
MCC 229-5	5	150	138	116	3
MCC 230-8	8	184	170	120	3.4
MCC 231-6	6	144	136	113	2.8
MCC 231-7	7	144	136	113	2.8
MCC 232-6	6	109.4	97	77.3	3.2
MCC 300-3	3	127	115	96	3
MCC 301-4	4	127	115	96	3
MCC 302-5	5	127	115	96	3
MCC 303-6	6	127	115	96	3

Lucas Nr.	NO.	A	B	C	D
MCC 304-5	4	152	138	116	3
	1	152	138	121	3.5
MCC 305-7	7	127	115	96	3
MCC 306-6	6	152	138	116	3
MCC 307-6	6	152	138	116	3.5
MCC 308-6	6	152	138	116	3
MCC 309-7	7	152	138	116	3
MCC 310-7	7	152	138	116	3
MCC 311-6	5	152	138	116	3
	1	152	138	121	3.5
MCC 312-8	8	152	138	116	3
MCC 313-8	8	152	138	116	2.8
MCC 314-8	7	152	138	116	3
	1	152	138	121	3.5
MCC 316-8	8	152	138	116	3
MCC 317-10	9	136	125	102	3
	1	136	125	108	3
MCC 318-8	8	153	145	120	3.25
MCC 319-9	8	136	125	102	3
	1	136	125	108	3
MCC 320-8	8	159	148	120.5	3
MCC 321-7	6	152	138	116	3
	1	152	138	121	3.5
MCC 322-10	8	161	151	129	3
	2	161	151	129	3.8
MCC 323-9	9	159	148	120.5	3
MCC 324-11	11	139	131	110	2.6
MCC 325-8	8	144	136	113	2.8
MCC 326-10	10	139	131	110	2.6
MCC 327-10	9	152	138	116	2.8
	1	152	138	121	3.5
MCC 328-7	7	151	138	116	2.8
MCC 328-8	8	152	138	116	2.8
MCC 328-9	9	152	138	116	2.8
MCC 329-8	8	144	132	112.5	3
MCC 330-5	4	127	115	96	3
	1	127	115	103.5	3
MCC 331-7	6	152	138	116	3
	1	152	138	116	3.5
MCC 333-6	6	152	138	116	2.8
MCC 334-5	5	152	138	116	3
MCC 336-6	6	127	115	96	2.8
MCC 336-7	7	127	115	96	2.8
MCC 336-8	8	127	115	96	2.8
MCC 337-9	9	144	132	112.5	3
MCC 338-7	7	153	145	120	3.25
MCC 339-8	6	144	136	113	2.8
	2	144	132	112.5	3
MCC 340-8	7	127	115	96	3
	1	127	115	103.5	3



Lucas Nr.	NO.	A	B	C	D
MCC 341-11	10	139	131	110	2.6
	1	139	131	116	2.6
MCC 342-8	7	152	138	116	3
	1	152	138	121	3.5
MCC 343-10	10	144	136	113	2.8
MCC 343-10RAC	10	144	136	113	2.8
MCC 344-9	9	150	139	121	3.25
	1	150	139	121	3.25
MCC 346-3	2	152	138	116	3
	1	152	138	121	3.5
MCC 348-10	8	136	125	102	3
	1	136	125	102	3
	1	136	125	108	3
MCC 349-10	8	161	151	129	3
	1	161	151	129	3.8
	1	161	151	135.5	3.8
MCC 350-10	10	150	139	121	3.25
MCC 351-3	2	152	138	116	3
	1	152	138	121	3.5
MCC 352-8	8	158	146	123	3.2
MCC 353-8	7	144	136	113	2.8
	1	144	132	118	2.8
MCC 354-9	8	144	136	113	2.8
	1	144	132	118	2.8
MCC 355-9	8	161	151	129	3.8
	1	161	151	135.5	3.8
MCC 356-6	6	150	139	121	3
MCC 357-8	8	158	146	123	3.1
MCC 358-9	8	150	139	117	3
	1	150	139	122	3
MCC 359-10	9	144	136	113	2.8
	1	144	132	118	2.8
MCC 360-7	6	150	138.7	116	3
	1	150	138.7	122	3
MCC 361-9	8	150	138.7	122	3.2
	1	150	138.8	112	3.3
MCC 362-5	5	136	125	101	2.4
MCC 363-6	5	127	115	96	2.8
	1	127	115	96	3
MCC 364-2	2	98	87	67	2.5
MCC 365-8	7	161	151	129	3.8
	1	161	151	135.5	3.8
MCC 400-2	2	123.5	115	100	3.5
MCC 401-3	3	123.5	115	100	3.5
MCC 402-4	4	123.5	115	100	3
MCC 403-5	5	123.5	115	100	3
MCC 404-6	6	123.5	115	100	3
MCC 405-6	6	134	122	107	3
MCC 406-7	7	148	134	116	3
MCC 407-7	7	148	134	111.5	3
MCC 408-5	5	148	134	116	3

Lucas Nr.	NO.	A	B	C	D
MCC 409-5	4	148	134	116	3
	1	148	134	112.5	3.5
MCC 410-6	6	148	134	111.5	2.8
MCC 411-5	5	166	152	129	3
MCC 412-8	8	148	134	111.5	2.8
MCC 413-6	6	155	143	120	3
MCC 414-8	7	148	134	111.5	3
	1	148	134	116	3
MCC 415-8	7	148	134	111.5	2.8
	1	148	134	116	3
MCC 416-8	6	148	134	111.5	2.8
	2	148	134	116	3
MCC 418-7	6	125	116	100	3
	1	125	115	100	3
MCC 419-8	8	148	134	112.5	3
MCC 420-9	9	125.2	115	100	3
MCC 421-6	6	166	152	124	3
MCC 422-9	7	148	134	112.5	3
	1	148	134	116	3
	1	148	134	111.5	3.5
MCC 423-8	8	155	143	120	3
MCC 424-7	7	148	134	111.5	2.8
MCC 425-9	8	134	120	97	3
	1	134	120	104.5	3
MCC 426-8	8	166	152	129	3
MCC 426-10	10	166	152	124	3
MCC 428-6	6	125.2	115.2	100	3
MCC 429-6	6	125.2	115.2	100	3
MCC 430-6	6	134	120	97	3
MCC 431-7	5	134	120	97	3
	2	134	120	104.5	3
MCC 432-7	7	136	125	102	3
MCC 433-4	4	133.5	122	100	3
MCC 434-7	7	148	134	112	3
MCC 435-7	7	155	143	120	3
MCC 436-8	8	125.2	115.2	100	3
MCC 437-7	7	166	152	129	3
MCC 438-8	6	166	152	124	3
	2	166	152	135.5	3
MCC 439-7	7	125.2	115.2	100	3
MCC 440-8	7	166	152	124	3
	1	166	152	135.5	3
MCC 441-9	9	134	120	97	3
MCC 442-9	9	148	134	112.5	3
MCC 443-6	6	136	125	108	3
MCC 443-7	7	136	125	108	3
MCC 443-8	8	136	125	108	3
MCC 444-6	6	148	134	112.5	3.5
MCC 445-8	7	150	139	117	3
	1	150	139	122	3



Lucas Nr.	NO.	A	B	C	D
MCC 446-8	7	166	152	129	3
	1	166	152	135.5	3
MCC 447-9	8	172	158	132.9	3
	1	172	158	142.5	3
MCC 449-8	6	136	125	108	3
	2	136	125	108	3
MCC 450-9	8	155	143	120	3
	1	155	143	120	3
MCC 451-9	7	134	120	97	3
	2	134	120	104.5	3
MCC 452-9	8	148	134	112.5	3
	1	148	134	116	3.5
MCC 454-9	8	166	152	129	3
	1	166	152	135.5	3
MCC 455-9	7	136	125	108	3
	2	136	125	108	3
MCC 456-7	6	155	143	120	3
	1	155	143	120	3
MCC 457-9	9	155	143	120	3
MCC 458-8	7	155	143	120	3
	1	155	143	120	3
MCC 459-10	9	166	152	129	3
	1	166	152	135.5	3
MCC 460-11	10	166	152	129	3
	1	166	152	135.5	3
MCC 461-9	9	166	152	129	3
MCC 462-5	4	134	122.5	99.5	3
	1	134	122.5	107.5	3
MCC 463-9	8	155	142	119.3	3
	1	155	142	119.5	3.8
MCC 500-8	8	117	105.5	91	2
MCC 501-9	9	155	143	120	2.7
MCC 501-9C	9	155	143	120	2.7
MCC 502-8	7	160	148	125	2.7
	1	160	148	127.2	2.7
MCC 503-8	8	160	148	125	2.7
MCC 503-8C	8	160	148	125	2.7
MCC 504-7	7	136	125	102	3
MCC 505-6	6	150	139	117	3
MCC 506-6	6	108	95	78	1.9
MCC 507-7	7	125	114	93	3
MCC 508-7	7	144	134	116	2
MCC 508-7C	7	144	134	116	2
MCC 509-11	10	144	136	113	2.8
	1	144	132	118	2.8
MCC 510-9	9	150	139	116	3
MCC 511-8	8	144	134	112	2
MCC 511-8C	8	144	134	112	2
MCC 512-8	8	159	147	134	2.7
MCC 513-5	4	119	110	91	3
	1	118.5	109.5	100	3.5
MCC 525-9	9	150	139	116	3

Lucas Nr.	NO.	A	B	C	D
MCC 530-7	7	144	134	116	1.9
MCC 530-7C	7	144	134	116	1.9
MCC 540-7	6	152	138	116	3
	1	150	138	120	3.5
MCC 541-6	6	134	119.6	95.6	3
MCC 550-4	4	125.2	115	100	3
MCC 551-9	9	157	146	123	3.5
MCC 552-6	6	130	116	96	3
MCC 553-10	9	150	139	117	3
	1	150	139	120	3
MCC 600	1	165			5.65
MCC 601	1	178			6
MCC 602	1	180			5.65
MCC 603	1	163.5			5.5
MCC 604-7	7	158	146	123	3.4
MCC 607	1	180			5.8
MCC 608	1	165			6.5
MCC 609	1	178	140	132	5.65
MCC 610-8	8	158	146	123	3.4
MCC 611-8	8	161	151	129	3.7
MCC 612-7	7	158	142	123	3.5
MCC 613-10	8	144	136	113	2.8
	1	144	132	118	2.8
	1	144	136	113	2.8
MCC 620-7	6	148	134	111.5	3
	1	148	134	116	3
MCC 621-10	9	150	139	117	3
	1	150	139	122	3
MCC 702-11	10	136	125	102	3
	1	136	125	108	3
MCC 704-11RAC	11	144	136	113	2.8
MCC 800-5	5	162	110	55.5	5.5
MCC 801-6	6	162	153	138	2.4
MCC 802-9	8	161	151	129.2	3.8
	1	161	151	139	3.8
MCC 803-8C	8	148		119.4	2.2

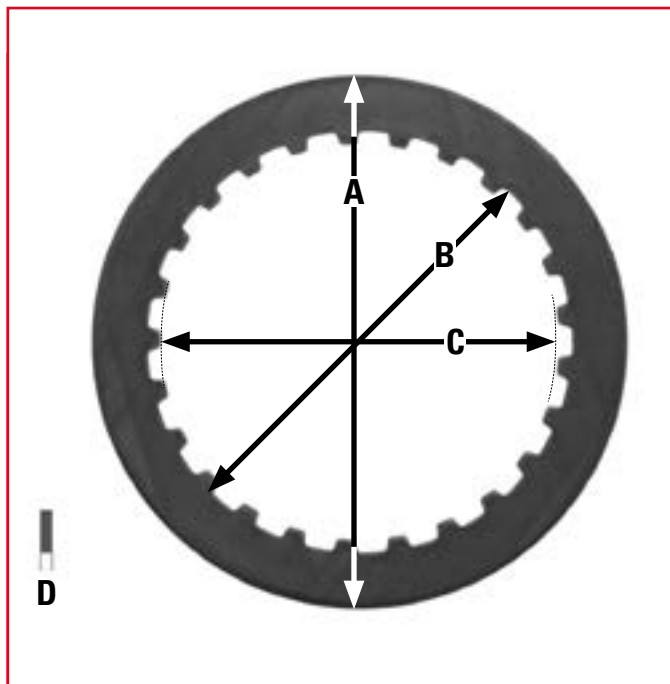

Lucas Nr.	NO.	A	B	C	D
MES301-4	4	139	113	102.5	1.5
MES301-6	6	139	113	102.5	1.5
MES302-6	6	132	103.5	96	1.6
MES303-5	5	145	122	112	2
MES303-6	6	145	122	112	2
MES303-7	7	145	122	112	2
MES304-7	7	145	122	112	1.5
MES305-6	6	145	122	112	2.3
MES305-8	8	145	122	112	2.3
MES306-7	7	140	114	105	1.5
MES307-6	6	133	104	96	1.5
MES308-7	7	145	122	112	1.5
MES309-4	4	110	90	85.2	1.4
MES309-5	5	110	90	85.2	1.4
MES309-7	7	110	90	85.2	1.4
MES310-5	5	125	97	90	1.5
MES310-6	6	125	97	90	1.5
MES310-7	7	125	97	90	1.5
MES310-9	9	133	103.5	96	2.3
MES311-8	8	151	122	112	2.8
MES312-11	11	139	110	103.8	1.6
MES313-3	3	122	101	89.3	1.6
MES314-7	7	134	110	100	1.6
MES315-4	4	134	110	100	2
MES315-7	7	134	110	100	2
MES315-8	8	134	110	100	2
MES316-8	8	142	114.5	105	1.6
MES317-4	4	115	94.5	86.5	1.2
MES317-6	6	115	94.5	86.5	1.2
MES318-7	7	134	110	100	1.2
MES318-8	8	134	110	100	1.2

Lucas Nr.	NO.	A	B	C	D
MES319-7	7	151	122	112	2
MES319-8	8	151	122	112	2
MES319-9	9	151	122	112	2
MES319-10	10	151	122	112	2
MES320-6	6	115	94.5	86.5	2
MES320-8	8	115	94.5	86.5	2
MES321-5	5	124	99	91.7	1.6
MES321-6	6	124	99	91.7	1.6
MES321-7	7	124	99	91.7	1.6
MES322-8	8	158	130	120	2.25
MES323-7	7	124	99	91.7	1.2
MES323-8	8	124	99	91.7	1.2
MES324-8	8	122	101	89.3	1.5
MES325-6	6	134	110	100	1.5
MES325-7	7	134	110	100	1.5
MES326-4	4	125	97	90	1.5
MES326-5	5	125	97	90	1.5
MES326-6	6	125	97	90	1.5
MES326-7	7	125	97	90	1.5
MES327-8	8	125	99	93	2.3
MES328-6	6	142	114.5	105	2
MES328-7	7	142	114.5	105	2
MES328-8	7	142	114.5	105	2
MES328-9	7	142	114.5	105	2
MES329-5	5	138	119	112	2
MES329-6	6	138	119	112	2
MES330-7	7	125	99	93	2.5
MES331-2	2	108	90.4	82.8	1.6
MES331-4	4	108	90.4	82.8	1.6
MES332-6	6	139	113.2	105	1.5
MES332-8	8	139	113.2	105	1.5
MES333-5	5	138.4	111	104.7	2
MES333-8	8	138.4	111	104.7	2
MES333-9	9	138.4	111	104.7	2
MES334-6	6	125	97	90	2
MES335-6	6	139	110	103.8	2
MES335-7	9	139	110	103.8	2
MES335-9	9	139	110	103.8	2
MES336-4	4	125	97	90	1.6
MES336-5	5	125	97	90	1.6
MES336-7	7	125	97	90	1.6
MES337-6	6	138	115.3	108.2	1.5
MES337-8	8	138	115.3	108.2	1.5
MES338-8	8	138	115.3	108.2	2
MES339-9	9	148	115.3	108.2	2
MES340-8	8	148	115.3	108.2	1.5
MES341-9	9	145	115.3	108.2	1.5
MES342-10	10	130	107	99	2



Lucas Nr.	NO.	A	B	C	D
MES343-6	6	125	99	93	2
MES343-8	8	125	99	93	2
MES344-7	7	139	115.2	104.2	2
MES344-9	9	139	115.2	104.2	2
MES345-4	4	115	96	87	2
MES345-5	4	115	96	87	2
MES346-7	7	132	107	99	1.4
MES347-4	4	115	95.8	86.8	1.6
MES348-8	8	145	115.3	108.2	2
MES349-7	7	120	93	85	1.5
MES350-8	8	142	119	110	1.2
MES351-7	7	148	123	113	1.5
MES352-6	6	142	114.5	105	1.6
MES354-7	7	132	103.5	96	1.6
MES354-8	8	132	103.5	96	1.6
MES355-7	7	151	126	115.5	1.6
MES356-7	6	133	110	103.8	2.6
	1	133	110	103.8	2.3
MES357-8	8	139	113.2	104	1.4
MES358-5	5	140	114	105	1.6
MES358-7	7	140	114	105	1.6
MES358-8	8	140	114	105	1.6
MES359-7	7	142	114.5	105	1.6
MES360-7	7	139	113.2	105	1.6
MES361-7	7	125	99	93	2.5
MES362-7	7	139	110	103.8	2.3
MES362-8	8	139	110	103.8	2.3
MES363-5	5	115	94.8	86.8	1.6
MES364-6	6	119.8	97.3	90.2	1.5
MES365-8	8	141.9	115	105.6	1.2
MES366-8	8	120	97.3	90.2	2
MES367-4	4	125.5	100.3	91.6	1.4
MES368-6	6	115	93.4	85.4	1.5
MES369-9	9	133.2	110.2	103.8	2.25
MES370-9	8	133.2	110.2	103.8	2.25
	1	132	110.2	103.8	2
MES371-4	4	110	90.2	85	1.6
MES372-8	8	141.9	115	105.5	2
MES373-6	4	134	110	100	1.6
	2	134	110	100	2
MES374-9	9	133	110.4	103.2	2.3
MES375-7	7	147.5	123.2	113.2	1.5
MES401-8	7	134	110	100	1.6
	1	134	110	100	2.3
MES402-6	4	134	110	100	2
	2	134	110	100	1.5
MES403-8	7	134	110	100	2
	1	134	110	100	2.3
MES404-6	5	142	114.5	105	1.6
	1	142	114.5	105	2.5

Lucas Nr.	NO.	A	B	C	D
MES404-7	6	142	114.5	105	1.6
	1	142	114.5	105	2.5
MES405-7	7	142	115	105	2
MES405-8	7	142	115	105	2
	1	142	114.5	105	2.5
MES406-6	6	151	122	112	2
MES407-6	5	134	110	100	1.5
	1	134	110	100	2
MES408-8	7	125	99	93	2.6
	1	125	99	93	2.3
MES409-8	7	125	99	93	2.3
	1	125	99	93	2.5
MES410-9	7	151	126	115.5	2
	2	151	126	115.5	2.25
MES411-7	5	139	113.2	105	1.5
	2	139	113.2	105	1.6
MES412-8	7	148	115.3	108.2	1.5
	1	148	115.3	108.2	2
MES413-9	7	125	99	93	2
	2	125	99	93	1.5
MES414-9	7	125	99	93	1.5
	2	125	99	93	2
MES415-8	7	132	110	104	2
	1	132	110	104	1.6
MES416-7	7	146	115.5	108	1.5
MES417-7	6	125	100	93.4	2.4
	1	125	100	93.4	2.2
MES419-6	4	138	115.3	108.2	1.5
MES420-8	4	134.5	107.8	101	1.2
	4	134.5	107.8	101	1
MES421-9	7	134.5	107.8	101	1.2
	2	134.5	107.8	101	1
MES422-8	7	134.5	107.8	101	1.4
	1	134.5	107.8	101	1
MES500-6	6	138	119.4	112.4	1.6
MES501-8	8	151	130.4	122.2	1.5
MES900-2	1	141.9	115	105.5	2.25
	1	141.9	115	105.5	1.6
MES901-2	1	132	110	103.8	2
	1	133	110	103.8	2.5
MES902-2	2	133	110	103.8	2.5
MES903-2	1	133	110	103.2	2
	1	133	110	103.2	2.6
MES904-2	1	151	122.2	112.2	1.6
	1	151	122.2	112.2	2.6





FUSSRASTENANLAGEN

SYSTÈMES DE REPOSE-PIEDS
REAR SETS

RACING RASTENANLAGEN

SYSTÈMES DE REPOSE-PIEDS RACING REAR SETS FOR RACING

» BLACK EDITION – Fußrastenanlagen

- » hochwertige Rastenanlagen für ambitionierte Sportfahrer „made in Germany“
- » mit CNC gefräste Anlagen, schwarz eloxiert und vormontiert
- » individuelle Verstellmöglichkeiten
- » Umkehrschaltung ohne großen Aufwand möglich
- » superleichte Ausführung ab ca. 700 Gramm
- » Racingrasten inkl. Teflonstopfen
- » Verstellbereich von: 28,5 mm → und 18 mm ↑

BLACK EDITION – Rear Sets

- » high-grade rear sets for ambitious racing drivers “made in Germany”
- » with CNC-milled units, anodised black and pre-assembled
- » individual adjustment options
- » reversing shift pattern also possible with no major effort
- » extremely light model from approximately 700 grammes
- » racing foot rests including Teflon bungs
- » adjustable: 28.5 mm → and 18 mm ↑

BLACK EDITION – Systèmes de repose-pieds

- » repose-pieds de qualité supérieure pour les conducteurs sportifs ambitieux « fabriqué en Allemagne »
- » avec équipements fraisés par CNC, anodisés noir et prémontés
- » possibilités de réglage personnalisé
- » connexion par couplage inversé possible sans grandes difficultés
- » modèle ultraléger à partir de 700 grammes
- » repose-pieds racing, y compris embouts en téflon
- » ajustable: 28,5 mm → et 18 mm ↑

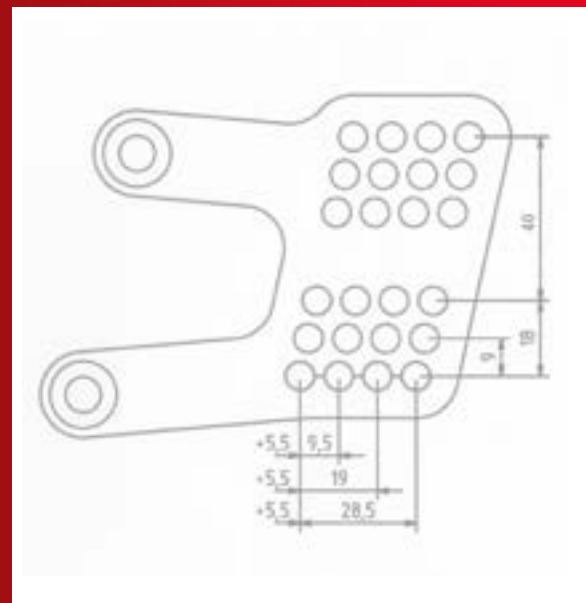

Beispiel Verstellbereich

Example for adjustment range

Exemple de plage de réglage

EINBAUBEISPIEL EXEMPLES D'INSTALLATION INSTALLATION EXAMPLES



Mit TÜV-Gutachten!

TÜV approved!

Homologué TÜV!

**Einbaubeispiel Suzuki GSX-R 1000
MCF 188 RAC**

*Installation example for
Suzuki GSX-R 1000
MCF 188 RAC*

*Exemple de montage sur
Suzuki GSX-R 1000
MCF 188 RAC*



**Einbaubeispiel Kawasaki Z 750 / Z 1000
MCF 115 RAC**

*Installation example for
Kawasaki Z 750 / Z 1000
MCF 115 RAC*

*Exemple de montage sur
Kawasaki Z 750 / Z 1000
MCF 115 RAC*



**Einbaubeispiel Ducati 1098 / 1198
MCF 118 RAC**

*Installation example for
Ducati 1098 / 1198
MCF 118 RAC*

*Exemple de montage sur
Ducati 1098 / 1198
MCF 118 RAC*

**Aprilia**

RSV	1000	Mille	ME / RP	98-03	MCF106RAC	Typ 1	System 1	1), 8)
RSV	1000	R	RR	04-	MCF107RAC	Typ 1	System 1	1), 17)
RSV	1000	R Tuono	RR	06-10	MCF107RAC	Typ 1	System 1	1)
RSV4	1000	R APRC, Factory, ABS	RK	09-	MCF108RAC	Typ 1	System 1	2), 19), bei ABS: 4) - MCH...
V4	1000	R Tuono APRC, ABS	TY	11-	MCF108RAC	Typ 1	System 1	2), 19), bei ABS: 4) - MCH...

BMW

S	1000	RR		09-13	MCF102RAC	Typ 4	System 4	7), 14), 15)
S	1000	RR		09-13	MCF102RAC-UM	Typ 3	System 2	9), 14), 16)
S	1000	R		14-	MCF102RAC	Typ 4	System 4	7), 14), 15)
S	1000	R		14-	MCF102RAC-UM	Typ 3	System 2	9), 14), 16)
S	1000	RR		15-	MCF100RAC	Typ 3	System 2	2)

Ducati

	696	Monster, ABS	M5	07-	MCF110RAC	Typ 1	--	6), 15), 19)
	796	Hypermotard	B1	09-12	MCF109RAC	Typ 4	--	16)
	796	Monster, S, ABS	M5	10-	MCF110RAC	Typ 1	--	6), 15), 19)
	848		H6	08-10	MCF118RAC	Typ 1	System 1	1)
	848	Evo	H6	10-13	MCF118RAC	Typ 1	System 1	
	1098	, S, R	H7	07-09	MCF118RAC	Typ 1	System 1	1), 19)
	1100	Monster, S, ABS	M5	08-	MCF110RAC	Typ 1	--	6), 15), 19)
	1100	Hypermotard, S	B1	07-12	MCF109RAC	Typ 1	--	6), 15)
	1100	Hypermotard Evo, Evo SP		10-	MCF109RAC	Typ 1	--	6), 15)
	1198	, S, R, SP	H7	08-	MCF118RAC	Typ 1	System 1	1), 19)
	1199	Panigale, S, R	H8	12-	MCF111RAC	Typ 1	--	15)

Honda

CBR	125	R	JC50	11-	MCF114RAC	Typ 1	System 1	
CBR	500	RA	PC44	13-	MCF125RAC	Typ 2	--	15), 16), bei ABS: 4) - MCH35FR
CBR	600	F	PC35	99-08	MCF128RAC	Typ 1	System 1	
CBR	600	RR	PC37	03-06	MCF194RAC	Typ 1	System 4	3)
CBR	600	RR	PC40	07-08	MCF194RAC	Typ 1	System 4	3)
CBR	600	RR, RA	PC40	09-12	MCF194RAC	Typ 1	System 4	9), bei ABS: 4) - MCH70FR
CBR	600	RR, RA	PC40	13-	MCF194RAC	Typ 1	System 4	9), bei ABS: 4) - MCH70FR
CBR	900	RR	SC44	00-02	MCF191RAC	Typ 1	System 1	
CBR	900	RR	SC50	02-03	MCF191RAC	Typ 1	System 1	
CBR	1000	RR	SC57	04-07	MCF195RAC	Typ 2	System 2	3)
CBR	1000	RR, ABS	SC59	08-	MCF116RAC	Typ 2	System 2	Bei ABS: 4) - MCH20FR
CB	1000	R, RA	SC60	08-	MCF119RAC	Typ 2	--	2), 15), bei ABE: 4) - MCH40FR

Kawasaki

ZX-6R	600	RR	ZX600N	05-06	MCF198RAC	Typ 1	System 1	Bei ABS: 4) - MCH25FR
ZX-6R	636	Ninja	ZX636C	05-06	MCF198RAC	Typ 1	System 1	Bei ABS: 4) - MCH25FR
ZX-6R	600	Ninja	ZX600P	07-08	MCF198RAC	Typ 1	System 1	Bei ABS: 4) - MCH362H1
ZX-6R	600	Ninja	ZX600R	09-12	MCF198RAC	Typ 1	System 1	2), 4) - MCH282H1
ZX-6R	636	Ninja ABS	ZX600E	12-	MCF133RAC	Typ 1	System 1	Bei ABS: 4) - MCH75FR
Z	750	, ABS	ZR750L	07-	MCF115RAC	Typ 1	System 1	Bei ABS: 4) - MCH45FR
Z	1000	, ABS	ZRT00B	07-09	MCF115RAC	Typ 1	System 1	Bei ABS: 4) - MCH45FR
Z	1000		ZRT00D	10-	MCF172RAC	Typ 1	System 1	
Z	1000	SX	ZXT00G	10-13	MCF172RAC	Typ 1	System 1	
ZX-10	1000	Ninja	ZXT00E	08-10	MCF117RAC	Typ 1	System 1	
ZX-10	1000	, ABS	ZXT00F	10-	MCF173RAC	Typ 1	System 1	10), bei ABS: 4) - MCH90FR

Suzuki

GSX-R	600		AD	96-00	MCF183RAC	Typ 1	System 1	18)
GSX-R	600		VWBG	01-03	MCF183RAC	Typ 1	System 1	18)
GSX-R	600		VWB2	04-05	MCF183RAC	Typ 1	System 1	
GSX-R	600		VWCE	06-07	MCF187RAC	Typ 3	System 3	
GSX-R	600		VWCV	08-10	MCF187RAC	Typ 3	System 3	
GSX-R	600		VWC3	11-	MCF189RAC	Typ 3	System 3	
GSF	600	Bandit	GN77B	94-99	MCF145RAC	Typ 1	System 1	18)
GSF	600	Bandit	VVA8	00-04	MCF145RAC	Typ 1	System 1	18)
GSF	650	Bandit	VVB5	05-06	MCF145RAC	Typ 1	System 1	
GSF	650	Bandit	VVCJ	07-	MCF113RAC	Typ 2	--	15)

GSX	650	FA	VVCJ	08-	MCF113RAC	Typ 2	—	15)
SV	650		AV111	98-02	MCF181RAC	Typ 1	System 1	18)
SV	650		VVBY	03-	MCF181RAC	Typ 1	System 1	
GSR	750	, ABS	VVC5	11-	MCF182RAC	Typ 1	System 1	
GSX-R	750		VVBD	00-03	MCF183RAC	Typ 1	System 1	18)
GSX-R	750		VVB3	04-05	MCF183RAC	Typ 1	System 1	
GSX-R	750		VVCF	06-07	MCF187RAC	Typ 3	System 3	
GSX-R	750		VVCW	08-10	MCF187RAC	Typ 3	System 3	
GSX-R	750		VVC4	11-	MCF189RAC	Typ 3	System 3	
GSX-S	1000	, F	DG	15-	MCF184RAC	Typ 1	System 1	
GSX-R	1000		VVBL	01-02	MCF183RAC	Typ 1	System 1	18)
GSX-R	1000		VVBZ	03-04	MCF183RAC	Typ 1	System 1	
GSX-R	1000		VVB6	05-06	MCF186RAC	Typ 1	System 1	
GSX-R	1000		VVCL	07-08	MCF196RAC	Typ 1	System 1	
GSX-R	1000		VVCY	09-	MCF188RAC	Typ 3	System 3	
SV	1000		VVBX	03-08	MCF181RAC	Typ 1	System 1	8), 11), bei ABS: 4) - MCH30FR
GSF	1200	Bandit	GV75A	96-00	MCF145RAC	Typ 1	System 1	18)
GSF	1200	Bandit	VVA9	01-05	MCF145RAC	Typ 1	System 1	18)
GSF	1200	Bandit	VVCB	06	MCF145RAC	Typ 1	System 1	
GSF	1250	Bandit	VVCH	07-	MCF113RAC	Typ 2	System 3	
GSX	1250	FA	VVCH	10-	MCF113RAC	Typ 2	System 3	
GSX	1300	Hayabusa	VVCK	08-	MCF166RAC	Typ 1	—	15)
GSX	1340	B-King	VVCR	08-	MCF163RAC	Typ 1	System 1	Bei ABS: 4) MCH55FR
Triumph								
	675	Daytona	D67LC	07-12	MCF197RAC	Typ 4	—	15)
	675	Daytona	D67LC	07-12	MCF197RAC-UM	Typ 3	System 3	5), 16)
	675	Street Triple	D67LD	07-12	MCF197RAC	Typ 4	—	15)
	675	Street Triple	D67LD	07-12	MCF197RAC-UM	Typ 3	System 3	5), 16)
	675	Street Triple, ABS	L67LR	13-	MCF190RAC	Typ 4	—	15), bei ABS: 4) - MCH50FR
	675	Street Triple, ABS	L67LR	13-	MCF190RAC-UM	Typ 3	System 3	16), bei ABS: 4) - MCH50FR
	675	Daytona R, ABS	H67	13-	MCF190RAC	Typ 4	—	15), bei ABS: 4) - MCH50FR
	675	Daytona R, ABS	H67	13-	MCF190RAC-UM	Typ 3	System 3	16), bei ABS: 4) - MCH50FR
	1050	Speed Triple, ABS	515NV	11-	MCF193RAC	Typ 1	—	15), bei ABS: 4) MCH...
Yamaha								
YZF	125	R	RE06	08-	MCF150RAC	Typ 4	—	15)
YZF	600	R6	RJ11	06-07	MCF169RAC	Typ 3	System 3	2)
YZF	600	R6	RJ15	08-	MCF169RAC	Typ 3	System 3	2)
	700	MT-07	RM04	14-	MCF103RAC	Typ 2	System 1	Bei ABS: 4) MCH65FR
FZ8	800	, Fazer 8, ABS	RN25	10-	MCF164RAC	Typ 4	—	15)
	850	MT-09	RN29	13-	MCF104RAC	Typ 2	System 1	
FZ1	1000	, Fazer	RN16	06-	MCF164RAC	Typ 4	—	7), 12), 15), 4) - MCH64FR
FZ1	1000	ABS, Fazer	RN16	06-	MCF164RAC	Typ 4	—	7), 12), 15), 4) - MCH60FR
YZF	1000	R1	RN12	04-06	MCF168RAC	Typ 4	System 4	13)
YZF	1000	R1	RN19	07-08	MCF199RAC	Typ 3	System 2	10)
YZF	1000	R1	RN22	09-	MCF162RAC	Typ 3	System 3	
YZF	1000	R1	RN32	15-	MCF161RAC	Typ 3	System 2	

- 1) Bremszylinder an der Rastenanlage montiert
- 2) inklusive Auspuffhalter
- 3) inklusive Halter für Hitzeblech
- 4) geänderte Bremsleitung - Art.-Nr. ... notwendig
- 5) Ritzelabdeckung entfernen
- 6) ohne Soziasraste
- 7) Schaltung durch den Rahmen
- 8) Kürzung Kolbenstange am Bremszylinder notwendig
- 9) Modifikation der Verkleidung notwendig
- 10) bei Umkehrschaltung, Ritzelabdeckung entfernen
- 11) eingeschränkter Verstellbereich
- 12) gebogene Schaltstange
- 13) Schaltung außerhalb des Rahmens
- 14) auch mit Quickshifter
- 15) nur Standard-Schaltschema möglich
- 16) nur Umkehrschaltung möglich
- 17) geänderte Verlegung der Bremsleitung notwendig
- 18) hydr. Bremslichtschalter MCF935 notwendig
- 19) nur Modelle ohne Quickshifter

Typen und Schaltungsumkehrungen
siehe Seite 5.06 - 5.07

- 1) brake cylinder mounted on the rear set
- 2) includes exhaust bracket
- 3) includes bracket for heat shield
- 4) altered brake line - art.no. ... - required
- 5) remove pinion cover
- 6) without pillion foot rest
- 7) shifting through the frame
- 8) shorter piston rod on brake cylinder required
- 9) modification of fairing required
- 10) remove pinion cover for reverse gearshift
- 11) limited adjustment range
- 12) curved gearshift rod
- 13) shifting outside the frame
- 14) also with Quickshift
- 15) only standard shifting scheme possible
- 16) only reverse gearshift possible
- 17) routing of brake line has to be changed
- 18) hydr. brake light switch MCF935 required
- 19) only models without Quickshift

Types and reverse gearshifts
see pages 5.06 - 5.07

- 1) cylindre de frein monté sur le système de repose-pieds
- 2) support pour échappement inclus
- 3) support pour tôle chauffante inclus
- 4) durite de frein modifiée - N° art. ... requis
- 5) retirer le capot du pignon
- 6) sans repose-pieds pour le passager
- 7) contact à travers le cadre
- 8) réduction de la tige de piston du cylindre de frein nécessaire
- 9) modification du revêtement requis
- 10) retirer le capot du pignon en cas de contact inversé
- 11) plage de réglage limitée
- 12) tige de sélection courbée
- 13) contact en dehors du cadre
- 14) également avec Quickshifter
- 15) schéma de couplage standard uniquement
- 16) contact inversé uniquement
- 17) pose modifiée de la durite de frein requise
- 18) contacteur hydr. pour feux stop MCF935 requis
- 19) modèles sans Quickshifter uniquement

Types et contacts inversés:
cf. pages 5.06 - 5.07

SCHALTTYPEN

TYPES DE COUPLAGES

SHIFTING TYPES

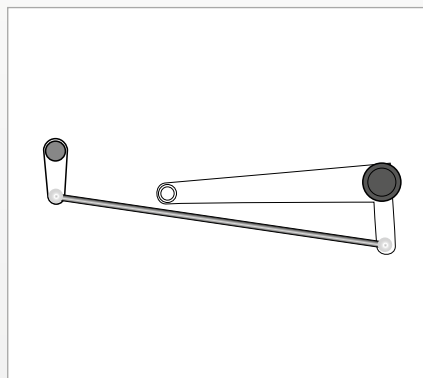

TYP 1

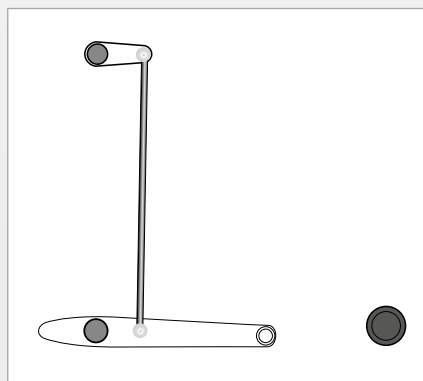

TYP 2

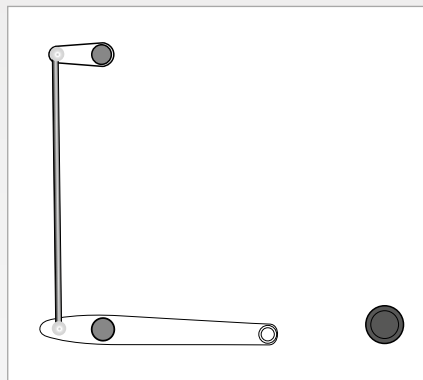

TYP 3

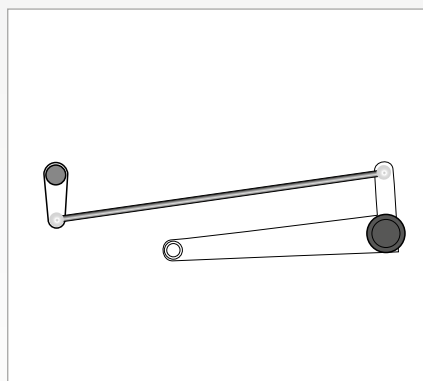

TYP 4

SCHALTUMKEHRUNGEN

COUPLAGES INVERSES
REVERSE GEARSHIFTS

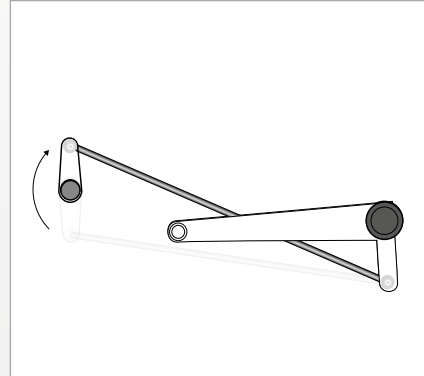

SYSTEM 1

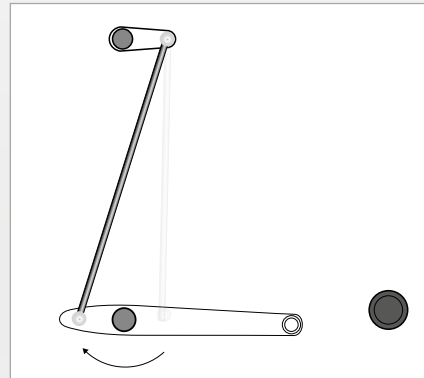

SYSTEM 2

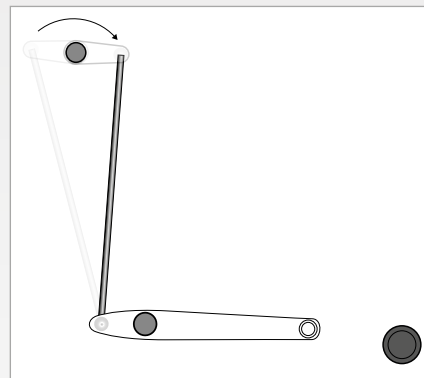

SYSTEM 3

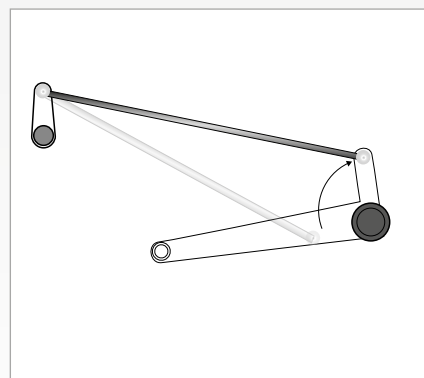

SYSTEM 4

ERATZTEILE & ZUBEHÖR

PIÈCES DE RECHANGE & ACCESSOIRES

SPARE PARTS & ACCESSORIES



Ersatzhebel, siehe Seite 5.11
Replacement lever, see page 5.11
Levier de rechange, cf. page 5.11



Bestell-Nr.
Order no.
N° comm.

MCF920 S

Ersatzteil Hebel (1 Stück)
Replacement part for lever (1 piece)
Pièce de rechange pour levier (1 pièce)



Bestell-Nr.
Order no.
N° comm.

MCF431 S

**Ersatz-Schaltstangen, Außengewinde r.,
 Innengewinde li. (Modell angeben)**
*Replacement shift rods, outer thread r.,
 inner thread l. (state model)*
**Tige de commande sélecteur de rechange,
 filetage extérieur dr., filetage intérieur g.
 (modèle indiqué)**



Ø Bohrung Ø Bore Ø Diam. trou	Gewinde Thread Filetage	Bestell-Nr. Order no. N° comm.
6 mm *	↻	MCF930
6 mm *	↺	MCF931
8 mm *	↻	MCF932
6 mm **	↻	MCF933
6 mm **	↺	MCF934

Kugelgelenkkopf
Tie rod end
Tête tournante

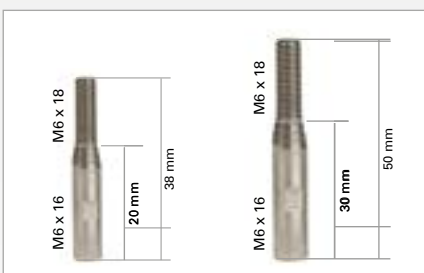

Verlängerung Extension Rallonge	Bestell-Nr. Order no. N° comm.
20 mm	MCF420
30 mm	MCF430

**Schaltstangenverlängerung aus Edel-
 stahl, Außengewinde r., Innengewinde r.**
*Shift rod extension, made of stainless
 steel, outer thread r., inner thread r.*
**Prolongateur de tige de commande sélec-
 teur en acier inoxydable, filetage extérieur
 dr., filetage intérieur dr.**



Bestell-Nr.
Order no.
N° comm.

MCF901 S 
MCF901 R 

Ersatzraste inkl. Befestigungsschraube
 (1 Stück)
*Replacement rest incl. attachment
 screw (1 piece)*
*Repose-pied de rechange incl. vis de
 fixation (1 pièce)*



Bestell-Nr.
Order no.
N° comm.

MCF905 S

Ersatzstopfen (2 Stück)

Replacement stoppers
(2 pieces)

Embouts de rechange
(2 pièces)



Bestell-Nr.
Order no.
N° comm.

M10x1.0

MCF935

M10x 1.25

MCF936

Hydraulischer Stopplichtscharter

Hydraulic stoplight switch

Contacteur hydraulique pour feux stopw



Bestell-Nr.
Order no.
N° comm.

M10x1.0

MCF937

M10x 1.25

MCF938

Hydraulischer Stopplichtscharter

Hydraulic stoplight switch

Contacteur hydraulique pour feux stopw



MCZ530

MCZ531

Bestell-Nr.
Order no.
N° comm.

gerade
straight
droit

schräg
diagonal
incliné

MCZ530

•

MCZ531

•

Bremsflüssigkeitsbehälter, Kunststoff, 15 ml

Brake fluid container, plastic

Réservoir de liquide de frein, plastique



MCZ530...

MCZ531...

Bestell-Nr.
Order no.
N° comm.

MCZ530 S



MCZ531 S



MCZ530 C



MCZ531 C



Bremsflüssigkeitsbehälter, Aluminium, 15 ml

Brake fluid container, aluminium

Réservoir de liquide de frein, aluminium



Bestell-Nr.
Order no.
N° comm.

MCF440 S



MCF440 C



Adapter zur Verlegung von Bremsflüssigkeitsbehältern



Adapter for relocating brake fluid reservoirs

Adaptateur pour la pose des réservoirs de liquide de frein

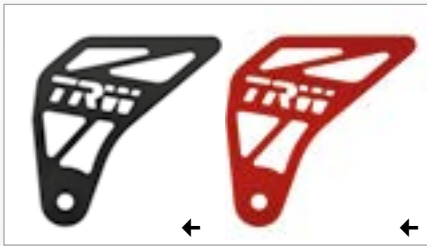
Universal Fersenschutz, links
Universal heel protection, left
Protège-talon universel, gauche



Aluminium

Bestell-Nr. Order no. N° comm.	Bestell-Nr. Order no. N° comm.
MCF927 S 	MCF927 R 



Carbon

Bestell-Nr. Order no. N° comm.
MCF928

Zusätzlicher Fersenschutz Aluminium, rechts
Additional heel protection, right
Protège-talon supplémentaire, droite



Bestell-Nr. Order no. N° comm.
MCF925 S



Ø Bohrung Ø Bore Ø Diam. trou	Bestell-Nr. Order no. N° comm.
6 mm	MCF923 S
8 mm	MCF924 S

FUSSBREMSZYLINDER

CYLINDRE DE FREIN A PIED

FOOT BRAKE CYLINDER

» Leichter, kompakter Fußbremszylinder

- » CNC-gefräst, hochfestes Aluminium
- » variable Befestigungspunkte, 37–50 mm
- » passend für alle TRW Fußrastenanlagen
- » auch für Fremdfabrikate geeignet
- » Betätigung über Kugelgelenk M8
- » Kolbendurchmesser 12,8 mm

» Lighter, more compact foot brake cylinder

- » CNC-milled, in high-strength aluminium
- » variable fixing points from 37 –50 mm
- » suitable for all TRW rear sets
- » also suitable for models from other manufacturers
- » activation by M8 ball joint
- » piston diameter 12.8 mm

» Cylindre de frein à pied plus léger et plus compact

- » fraisé par CNC, en aluminium extrêmement résistant
- » points de serrage variables de 37–50 mm
- » convient à tous les systèmes de repose-pieds
- » convient également pour les produits étrangers
- » fonctionne avec une rotule M8
- » diamètre de piston 12,8 mm



Bestell-Nr.
Order no.
N° comm.

MCF911 S 
MCF911 C 
MCF911 G 

MCF102RAC	MCF474S	MCF507S	MCF414-L	MCF414-R	MCF600-L	MCF600-R	MCF523	MCF431S	MCF927S	MCF923S
MCF102RAC-UM	MCF460S	MCF507S	MCF414-L	MCF414-R	MCF600-L	MCF600-R	MCF523	MCF431S	MCF927S	MCF923S
MCF103RAC	MCF465S	MCF539S	MCF448-L	MCF488-R	MCF600-L	MCF600-R	MCF534	MCF431S	MCF927S	MCF924S
MCF104RAC			MCF434-L	MCF434-R	MCF600-L	MCF600-R		MCF431S	MCF927S	MCF901S
MCF106RAC	MCF463S	MCF503S	MCF406-L	MCF406-R	MCF600-L	MCF600-R	MCF507	MCF431S	MCF927S	MCF923S
MCF107RAC	MCF463S	MCF503S	MCF407-L	MCF407-R	MCF600-L	MCF600-R	MCF507	MCF431S	MCF927S	MCF923S
MCF108RAC	MCF468S	MCF517S	MCF410-L	MCF410-R	MCF600-L	MCF600-R	MCF528	MCF431S	MCF927S	MCF923S
MCF109RAC	MCF453S	MCF553S	MCF425-L	MCF425-R	3)	3)	3)	2)	MCF927S	MCF925S
MCF110RAC	MCF463S	MCF507S	MCF426-L	MCF426-R	3)	3)	3)	MCF431S	MCF927S	MCF925S
MCF111RAC			MCF436-L	MCF436-R	MCF600-L	MCF600-R		MCF920S	MCF927S	
MCF113RAC	MCF472S	MCF506S	MCF405-L	MCF405-R	MCF600-L	MCF600-R	MCF520	2)	MCF927S	MCF924S
MCF114RAC			MCF443-L	MCF443-R	MCF600-L	MCF600-R		MCF431S	MCF927S	
MCF115RAC	MCF468S	MCF503S	MCF400-L	MCF400-R	MCF600-L	MCF600-R	MCF517	MCF431S	MCF927S	MCF924S
MCF116RAC	MCF480S	MCF502S	MCF402-L	MCF402-R	MCF600-L	MCF600-R	MCF516	MCF431S	MCF927S	MCF923S
MCF117RAC	MCF468S	MCF503S	MCF408-L	MCF408-R	MCF600-L	MCF600-R	MCF510	MCF431S	MCF927S	MCF924S
MCF118RAC	MCF461S	MCF501S	MCF401-L	MCF401-R	MCF610-L	MCF610-R	4)	MCF431S	MCF927S	MCF925S
MCF119RAC	MCF473S	MCF506S	MCF416-L	MCF416-R	MCF600-L	MCF600-R	MCF521	MCF431S	MCF927S	MCF923S
MCF125RAC	MCF473S	MCF505S	MCF437-L	MCF437-R	MCF600-L	MCF600-R	MCF509	MCF431S	MCF927S	MCF923S
MCF128RAC	MCF468S	MCF505S	MCF403-L	MCF403-R	MCF600-L	MCF600-R	MCF509	MCF431S	MCF927S	MCF923S
MCF133RAC	MCF468S	MCF507S	MCF435-L	MCF435-R	MCF600-L	MCF600-R	MCF513	MCF431S	MCF927S	
MCF145RAC	MCF468S	MCF506S	MCF419-L	MCF419-R	MCF600-L	MCF600-R	MCF536	MCF431S	MCF927S	MCF924S
MCF150RAC	MCF454S	MCF507S	MCF493-L	MCF493-R	MCF600-L	MCF600-R	MCF538	MCF431S	MCF927S	MCF923S
MCF161RAC			MCF438-L	MCF438-R	MCF600-L	MCF600-R		MCF431S	MCF927S	
MCF162RAC	MCF475S	MCF509S	MCF404-L	MCF404-R	MCF600-L	MCF600-R	MCF524	2)	MCF927S	MCF923S
MCF163RAC	MCF468S	MCF506S	MCF417-L	MCF417-R	MCF600-L	MCF600-R	MCF511	MCF431S	MCF927S	MCF923S
MCF164RAC	MCF465S	MCF505S	MCF409-L	MCF409-R	MCF600-L	MCF600-R	MCF527	MCF431S	MCF927S	MCF924S
MCF166RAC	MCF468S	MCF506S	MCF411-L	MCF411-R	MCF600-L	MCF600-R	MCF529	MCF431S	MCF927S	MCF923S
MCF168RAC	MCF465S	MCF554S	MCF424-L	MCF424-R	MCF600-L	MCF600-R	MCF537	MCF431S	MCF927S	1)
MCF169RAC	MCF471S	MCF507S	MCF482-L	MCF482-R	MCF600-L	MCF600-R	MCF519	MCF431S	MCF927S	MCF923S
MCF172RAC	MCF468S	MCF503S	MCF427-L	MCF427-R	MCF600-L	MCF600-R	MCF517	MCF431S	MCF927S	MCF924S
MCF173RAC	MCF468S	MCF535S	MCF428-L	MCF428-R	MCF600-L	MCF600-R	MCF534	MCF431S	MCF927S	1)
MCF181RAC	MCF468S	MCF506S	MCF415-L	MCF415-R	MCF600-L	MCF600-R	MCF529	MCF431S	MCF927S	MCF923S
MCF182RAC	MCF468S	MCF506S	MCF429-L	MCF429-R	MCF600-L	MCF600-R	MCF515	MCF431S	MCF927S	MCF923S
MCF183RAC	MCF468S	MCF506S	MCF481-L	MCF481-R	MCF600-L	MCF600-R	MCF515	MCF431S	MCF927S	MCF923S
MCF184RAC			MCF439-L	MCF439-R	MCF600-L	MCF600-R		MCF431S	MCF927S	
MCF186RAC	MCF466S	MCF506S	MCF483-L	MCF483-R	MCF600-L	MCF600-R	MCF515	MCF431S	MCF927S	MCF923S
MCF187RAC	MCF462S	MCF506S	MCF487-L	MCF487-R	MCF600-L	MCF600-R	MCF511	2)	MCF927S	MCF923S
MCF188RAC	MCF462S	MCF506S	MCF412-L	MCF412-R	MCF600-L	MCF600-R	MCF515	2)	MCF927S	MCF923S
MCF189RAC	MCF462S	MCF506S	MCF418-L	MCF418-R	MCF600-L	MCF600-R	MCF515	2)	MCF927S	MCF923S
MCF190RAC	MCF465S	MCF507S	MCF433-L	MCF433-R	MCF600-L	MCF600-R	MCF513	MCF431S	MCF927S	MCF924S
MCF190RAC-UM	MCF470S	MCF507S	MCF433-L	MCF433-R	MCF600-L	MCF600-R	MCF513	MCF431S	MCF927S	
MCF191RAC	MCF468S	MCF507S	MCF413-L	MCF413-R	MCF600-L	MCF600-R	MCF531	MCF431S	MCF927S	MCF923S
MCF193RAC	MCF468S	MCF535S	MCF423-L	MCF423-R	MCF600-L	MCF600-R	MCF533	MCF431S	MCF927S	1)
MCF194RAC	MCF465S	MCF505S	MCF494-L	MCF494-R	MCF600-L	MCF600-R	MCF509	MCF431S	MCF927S	MCF923S
MCF195RAC	MCF464S	MCF505S	MCF495-L	MCF495-R	MCF600-L	MCF600-R	MCF509	MCF431S	MCF927S	MCF923S
MCF196RAC	MCF466S	MCF506S	MCF496-L	MCF496-R	MCF600-L	MCF600-R	MCF515	MCF431S	MCF927S	MCF923S
MCF197RAC	MCF465S	MCF507S	MCF497-L	MCF497-R	MCF600-L	MCF600-R	MCF513	MCF431S	MCF927S	MCF924S
MCF197RAC-UM	MCF470S	MCF507S	MCF497-L	MCF497-R	MCF600-L	MCF600-R	MCF513	MCF431S	MCF927S	MCF924S
MCF198RAC	MCF468S	MCF503S	MCF498-L	MCF498-R	MCF600-L	MCF600-R	MCF510	MCF431S	MCF927S	MCF924S
MCF199RAC	MCF469S	MCF509S	MCF499-L	MCF499-R	MCF600-L	MCF600-R	MCF514	MCF431S	MCF927S	MCF924S

1) konstruktionsbedingt kein Fersenschutz montierbar
 2) Verwendung der originalen Schaltstange
 3) einteilige Konstruktion von Adapterplatte, Grundplatte und Halter für Bremszylinder
 4) Bremszylinder nicht an Fußrastenanlage montiert

1) due to the design, no heel guard can be installed
 2) use the original shifting rod
 3) one-part design of the adapter plate, baseplate and bracket for the brake cylinder
 4) brake cylinder not installed on the footrest system

1) montage de protège-talons impossible en raison de la conception
 2) utilisation de la tige de sélection d'origine
 3) conception d'une pièce de l'adaptateur, du socle et du support pour cylindre de frein
 4) cylindre de frein non monté sur le système de repose-pieds

ADAPTERPLATTEN

ADAPTATEURS

ADAPTER PLATES

» mit ABE, keine Eintragung nötig

- » Adapterplatten zur Verlegung von Original-Fußrastenanlagen
- » hochfeste Aluminiumprodukte aus CNC-Fertigung
- » variable Rastenposition für komfortable Sitzposition
- » mehr Bodenfreiheit durch geänderte Fußrastenposition
- » bei einigen Modellen empfiehlt sich der Austausch des Stopplichts, siehe Seite 5.09
- » je nach Modell sind die Adapterplatten silber oder schwarz
- » bei Fahrzeugen die im OE bereits mit einer Adapterplatte ausgerüstet sind, ersetzt die TRW Adapterplatte das OE Teil und verfügt über einen größeren Verstellbereich.

» with TÜV approval

- » adapter plates for adjusting original footrest assemblies
- » highly stable CNC manufactured aluminium products
- » variable positions to make riding more comfortable
- » raises the footrest position for greater ground clearance
- » for some models, we recommend replacing the stoplight switch, see page 5.09
- » depending on the model, the adapter plates are silver or black
- » for vehicles which are already equipped with an adapter plate in the OE, the TRW adapter plate replaces the OE part offering a larger adjustment range.

» avec homologation TÜV

- » adaptateurs pour la pose de systèmes de repose-pieds d'origine
- » produits en aluminium extrêmement résistant, produit par CNC
- » position variable des repose-pieds pour une position de conduite plus agréable
- » garde au sol supérieure grâce à une position modifiée des repose-pieds
- » sur certains modèles, il est recommandé des remplacer le contacteur de feux stop, cf. page 5.09
- » selon le modèle, les plateaux d'adaptateur sont argentés ou noirs
- » pour les motos ayant déjà une platine repose pied, la platine TRW la remplace et permet une plus grande plage de réglage.



Verlegungsmöglichkeiten für Original-Fußrastenanlagen:

Makes original rear sets adjustable:

Possibilité d'ajustement avec les systèmes de repose-pieds d'origine:

- 26 mm – 46 mm
- ↑ max. 25 mm
- ↓ max. 10 mm





**Einbaubeispiel Kawasaki ZX-10R
MCF 778-L und MCF 778-R**

*Installation example for
Kawasaki ZX-10R
MCF 778-L and MCF 778-R*

*Exemple de montage sur
Kawasaki ZX-10R
MCF 778-L et MCF 778-R*



**Einbaubeispiel Honda CBR900 RR
MCF 794-L und MCF 794-R**

*Installation example for
Honda CBR900RR
MCF 794-L and MCF 794-R*

*Exemple de montage sur
Honda CBR900 RR
MCF 794-L et MCF 794-R*

							Farbe Colour Couleur	
Aprilia								
RSV	1000	Mille	ME	98-00	MCF 706-L	MCF 706-R	===	
RSV	1000	Mille	RP	01-03	MCF 706-L	MCF 706-R	===	
RSV	1000	Mille R	RP	01-03	MCF 706-L	MCF 706-R	===	
RSV	1000	Mille SP	RP	01-03	MCF 706-L	MCF 706-R	===	
RSV	1000	R	RR	04-08	MCF 707-L	MCF 707-R	===	
Honda								
CBR	600	F	PC35	99-	MCF 728-L	MCF 728-R	===	
CBR	600	RR	PC37	03-06	MCF 794-L	MCF 794-R	===	
CBR	600	RR	PC40	07-08	MCF 794-L	MCF 794-R	===	2)
CBR	600	RR	PC40	09-	MCF 794-L	MCF 794-R	===	2)
CBR	900	RR	SC28	92-93	MCF 721-L	MCF 721-R	===	
CBR	900	RR	SC28	94-95	MCF 721-L	MCF 721-R	===	
CBR	900	RR	SC33	96-97	MCF 721-L	MCF 721-R	===	
CBR	900	RR	SC33	98-99	MCF 721-L	MCF 721-R	===	
CBR	900	RR	SC44	00-01	MCF 791-L	MCF 791-R	===	
CBR	954	RR	SC50	02-03	MCF 791-L	MCF 791-R	===	
CBR	1000	RR	SC57	04-07	MCF 794-L	MCF 794-R	===	2).
VTR	1000	SP1	RC51	00-	MCF 792-L	MCF 792-R	===	

Farbe
Colour
Couleur**Kawasaki**

ZX-6R	600	Ninja	ZX600F	94-97	MCF 730-L	MCF 730-R	≡≡≡	
ZX-6R	600	Ninja	ZX600G/H	98-02	MCF 738-L	MCF 738-R	≡≡≡	
ZX-6R	600	RR	ZX600K	03-04	MCF 777-L	MCF 777-R	≡≡≡	
ZX-6R	600	RR	ZX600N	05-06	MCF 771-L	MCF 771-R	≡≡≡	
ZX-6R	600	Ninja	ZX600P	07-08	MCF 795-L	MCF 795-R	≡≡≡	
ZX-6R	600	Ninja	ZX600R	09-	MCF 795-L	MCF 795-R	≡≡≡	2)
ZX-6R	636	Ninja	ZX636A	02	MCF 738-L	MCF 738-R	≡≡≡	
ZX-6R	636	Ninja	ZX600B	03-04	MCF 777-L	MCF 777-R	≡≡≡	
ZX-6R	636	Ninja	ZX600C	05-06	MCF 771-L	MCF 771-R	≡≡≡	
ZX-7R	750	Ninja	ZX750N	96-	MCF 730-L	MCF 730-R	≡≡≡	
ZX-7R	750	Ninja	ZX750P	96-	MCF 730-L	MCF 730-R	≡≡≡	
Z	750		ZR750L	07-	MCF 739-L	MCF 739-R	≡≡≡	
ZXR	750		ZX750J	91-95	MCF 730-L	MCF 730-R	≡≡≡	
ZXR	750	R	ZX750L	91-95	MCF 730-L	MCF 730-R	≡≡≡	
ZXR	750	R	ZX750K	91-92	MCF 730-L	MCF 730-R	≡≡≡	
ZXR	750	R	ZX750M	93-95	MCF 730-L	MCF 730-R	≡≡≡	
ZX-9R	900	Ninja	ZX900B	93-97	MCF 730-L	MCF 730-R	≡≡≡	
ZX-9R	900	Ninja	ZX900C	98	MCF 738-L	MCF 738-R	≡≡≡	
ZX-9R	900	Ninja	ZX900D	98-99	MCF 738-L	MCF 738-R	≡≡≡	
ZX-9R	900	Ninja	ZX900E	00-03	MCF 738-L	MCF 738-R	≡≡≡	
Z	1000		ZRT00E	07- 09	MCF 739-L	MCF 739-R	≡≡≡	6)
ZX-10R	1000	Ninja	ZXT00C	04-05	MCF 779-L	MCF 779-R	≡≡≡	7)
ZX-10R	1000	Ninja	ZXT00D	06 -07	MCF 778-L	MCF 778-R	≡≡≡	
ZX-10R	1000	Ninja	ZXT00E	08-10	MCF 717-L	MCF 717-R	≡≡≡	

Suzuki

GSF	600	Bandit	GN77B	94-99	MCF 745-L	MCF 745-R	≡≡≡	3)
GSF	600	Bandit	WVA8	00-04	MCF 745-L	MCF 745-R	≡≡≡	3)
GSF	650	Bandit	WVB5	05-06	MCF 745-L	MCF 745-R	≡≡≡	4)
GSF	650	Bandit	WVCJ	07-	MCF 746-L	MCF 746-R	≡≡≡	
GSX-R	600		AD311	96-00	MCF 741-L	MCF 741-R	≡≡≡	
GSX-R	600		WVBG	01-03	MCF 741-L	MCF 741-R	≡≡≡	
GSX-R	600		WVB2	04-05	MCF 741-L	MCF 741-R	≡≡≡	
GSX-R	600		WVCE	06-07	MCF 787-L	MCF 787-R	≡≡≡	1)
GSX-R	600		WVCV	08-10	MCF 787-L	MCF 787-R	≡≡≡	1)
GSX-R	600		C3	11-	MCF 708-L	MCF 708-R	≡≡≡	1)
SV	650		AV111	99-02	MCF 741-L	MCF 741-R	≡≡≡	3)
SV	650		WVBY	03-	MCF 741-L	MCF 741-R	≡≡≡	
GSX-R	750	W	GR7DB	96-99	MCF 741-L	MCF 741-R	≡≡≡	
GSX-R	750	W	WVBD	00-03	MCF 741-L	MCF 741-R	≡≡≡	
GSX-R	750		WVB3	04-05	MCF 741-L	MCF 741-R	≡≡≡	
GSX-R	750		WVCF	06-07	MCF 787-L	MCF 787-R	≡≡≡	1)
GSX-R	750		WVCW	08-10	MCF 787-L	MCF 787-R	≡≡≡	1)
GSX-R	750		C4	11-	MCF 708-L	MCF 708-R	≡≡≡	1)
GSX-R	1000		WVBL	01-02	MCF 741-L	MCF 741-R	≡≡≡	
GSX-R	1000		WVBZ	03-04	MCF 741-L	MCF 741-R	≡≡≡	
GSX-R	1000		WVB6	05-06	MCF 786-L	MCF 786-R	≡≡≡	
GSX-R	1000		WVCL	07-08	MCF 796-L	MCF 796-R	≡≡≡	
GSX-R	1000		WVCY	09-	MCF 797-L	MCF 797-R	≡≡≡	
SV	1000		WVBX	03-	MCF 741-L	MCF 741-R	≡≡≡	
GSX-R	1100	W	GU75C	93-97	MCF 743-L	MCF 743-R	≡≡≡	
GSF	1200	Bandit	GV75A	96-00	MCF 745-L	MCF 745-R	≡≡≡	3)
GSF	1200	Bandit	WVA9	01-05	MCF 745-L	MCF 745-R	≡≡≡	3)
GSF	1200	Bandit	WVCB	06	MCF 745-L	MCF 745-R	≡≡≡	4)
GSF	1250	Bandit	WVCH	07-	MCF 746-L	MCF 746-R	≡≡≡	

Triumph

	900	Speed Triple	T509	97-99	MCF 760-L	MCF 760-R	≡≡≡	
	950	Daytona	T595	97-98	MCF 760-L	MCF 760-R	≡≡≡	
	955	Daytona i	T595	99-	MCF 760-L	MCF 760-R	≡≡≡	
	955	Speed Triple	595 RPT	00-	MCF 760-L	MCF 760-R	≡≡≡	

Yamaha

YZF	600	R6	RJ05	03	MCF 767-L	MCF 767-R	≡≡≡	5)
YZF	600	R6	RJ09	04-05	MCF 767-L	MCF 767-R	≡≡≡	5)

1) vier Lochreihen

2) Hitzeblech entfällt

3) hydraulischer Stoplichtschalter MCF 935 notwendig

4) hydraulischer Stoplichtschalter MCF 936 notwendig

5) Schaltung außerhalb des Rahmens

6) Modifikation Rahmenblende notwendig

7) Eingeschränkter Verstellbereich

1) four rows of holes

2) no heat shield

3) hydraulic stoplight switch MCF 935 required

4) hydraulic stoplight switch MCF 936 required

5) shifting outside the frame

6) modification of frame panel required

7) Limited adjustment range

1) quatre rangées de trous

2) suppression de la tôle chauffante

3) contacteur hydraulique pour feux stop MCF935 requis

4) contacteur hydraulique pour feux stop MCF936 requis

5) contact en dehors du cadre

6) modification requise du panneau du cadre

7) Plage de réglages limitée



LENKER
GUIDONS
HANDLEBARS

ALUMINIUMLENKER

GUIDONS ALUMINIUM ALUMINIUM HANDLEBARS

» mit ABE, keine Eintragung nötig

- » hochwertige Aluminiumlenker mit eloxierter Oberfläche
- » hochfeste Alulegierung
- » Superbike Lenker wahlweise mit 22 mm oder 28mm Durchm. an der Klemmung
- » ideal für den Gabelbrücken-Umbau oder für Naked Bikes
- » Lenkerenden Classic sind in Form und Farbe auf die Lenker abgestimmt
- » konischer Offroad-Lenker hat eine perl-sandgestrahlte Oberfläche
- » klassischer Offroad-Lenker bevorzugt bei Reiseenduros oder Quads
- » Wandstärke Superbike und Speedfighter 5 mm, Offroad 4 mm

» with TÜV approval

- » high-quality anodised aluminium handlebars
- » high strength aluminium alloy
- » "Superbike" handlebars with a choice of a 22 mm or 28 mm diameter on the clamp
- » ideal for triple clamp conversions or for "Naked Bikes"
- » the shape and colour of the classic handlebar ends complement the handlebars
- » the conical offroad handlebars have a sandblasted surface
- » classic offroad handlebars are preferred for dual-purpose bikes and for quads
- » wall thickness Superbike and Speedfighter 5 mm, Offroad 4 mm

» avec homologation TÜV

- » guidon en aluminium haute qualité avec surface anodisée
- » alliage en aluminium à haute résistance
- » guidon supermoto avec diamètre 22 mm ou 28 mm au choix pour le serrage
- » idéal pour la transformation des fourches ou pour les «motos nues» (Naked Bikes)
- » embouts pour guidon classiques concordant avec la forme et la couleur du guidon
- » le guidon tout-terrain conique a une surface couleur sable
- » guidon tout-terrain classique préféré sur les enduros de tourisme ou les quads
- » épaisseur pour Superbike et Speedfighter: 5 mm, Offroad: 4 mm

SUPERBIKE, 22 MM











NEU: CB und SB sind perl-sandgestrahlt

NEW: CB and SB are sand blasted

NOUVEAU : CB et SB en sablage perl-sand

Bestell-Nr.
Order no.
N° comm.

MCL100 B	
MCL100 R	
MCL100 C	
MCL100 CB	
MCL100 S	
MCL100 SB	
MCL100 G	
MCL100 T	

5 mm Wandstärke
5 mm wall thickness
épaisseur 5 mm

SPEEDFIGHTER, 22 MM



Bestell-Nr. <i>Order no.</i> <i>N° comm.</i>	
MCL150 C	
MCL150 B	
MCL150 T	

5 mm Wandstärke
5 mm wall thickness
épaisseur 5 mm

SUPERBIKE KONISCH, 28 MM



Bestell-Nr. <i>Order no.</i> <i>N° comm.</i>	
MCL152 C	
MCL152 S	

Adapter separat bestellen.
Order adapter separately.
Commander l'adaptateur séparément.

Adapter für 28-mm-Lenker zur Montage an 22-mm-Lenkeraufnahmen (2 Stück)
Adapter for 28-mm-handlebar for installation on 22-mm-handlebar clamps (2 pieces)
Adaptateur pour guidon de 28 mm pour montage sur supports de guidon de 22 mm (2 pièces)

Adapter-Set für 28-mm-Lenker (2 Stück)
Adapter set for 28-mm-handlebar (2 pieces)
Kit d'adaptation pour guidon de 28 mm (2 pièces)



Bestell-Nr. <i>Order no.</i> <i>N° comm.</i>	
MCL350 C	
MCL350 S	



Bestell-Nr. <i>Order no.</i> <i>N° comm.</i>	
MCL450 C	
MCL450 S	



Bestell-Nr. <i>Order no.</i> <i>N° comm.</i>	
MCL650 C	
MCL650 S	

OFFROAD, 22 MM



Auch passend
für Quads

Also suitable
for quads

Convient
également pour
les quads

MC Low

Bestell-Nr.
Order no.
N° comm.

MCL153 C

MCL153 B

MCL153 T

MC Medium

Bestell-Nr.
Order no.
N° comm.

MCL154 C

MCL154 B

MCL154 T

MC High

Bestell-Nr.
Order no.
N° comm.

MCL155 C

MCL155 B

MCL155 T

Lenker mit Mittelstrebe in 4 mm Wandstärke

Handlebars with brace, 4 mm wall thickness

Guidon avec barre de renforcement, épaisseur 4 mm



LENKERENDEN

EMBOUTS POUR GUIDONS
HANDLEBAR ENDS



Mini MCL202 C MCL203 S MCL201 R MCL200 B MCL204 G

Classic	
Classic	
Classic	
MCL212 B	
MCL212 R	
MCL212 C	
MCL212 S	
MCL212 G	
MCL212 T	



Für MCL152... For MCL152... Pour MCL152...	
MCL214 C	
MCL214 S	

Bestell-Nr. Order no. N° comm.					A	B	C	D	E	F	Ø	Typ
MCL100 B		Superbike	MCL200 B	MCL212 B	750	53	219	110	145	91	22	0365
MCL100 R		Superbike	MCL201 R	MCL212 R	750	53	219	110	145	91	22	0365
MCL100 C		Superbike	MCL202 C	MCL212 C	750	53	219	110	145	91	22	0365
MCL100 CB		Superbike	MCL202 C	MCL212 C	750	53	219	110	145	91	22	0365
MCL100 S		Superbike	MCL203 S	MCL212 S	750	53	219	110	145	91	22	0365
MCL100 SB		Superbike	MCL203 S	MCL212 S	750	53	219	110	145	91	22	0365
MCL100 G		Superbike	MCL204 G	MCL212 G	750	53	219	110	145	91	22	0365
MCL100 T		Superbike	MCL203 S	MCL212 T	750	53	219	110	145	91	22	0365
MCL150 B		Speedfighter	MCL200 B	MCL212 B	861	47	240	79	153	67	22	0366
MCL150 C		Speedfighter	MCL202 C	MCL212 C	861	47	240	79	153	67	22	0366
MCL150 T		Speedfighter	MCL203 S	MCL212 T	861	47	240	79	153	67	22	0366
MCL152 C		Superbike		MCL214 C	795	64	205	95	178	64	28	0370
MCL152 S		Superbike		MCL214 S	795	64	205	95	178	64	28	0370
MCL153 B		Offroad low			805	42	217	65	120	68	22	0367
MCL153 C		Offroad low			805	42	217	65	120	68	22	0367
MCL153 T		Offroad low			805	42	217	65	120	68	22	0367
MCL154 B		Offroad medium			799	55	208	79	154	61	22	0368
MCL154 C		Offroad medium			799	55	208	79	154	61	22	0368
MCL154 T		Offroad medium			799	55	208	79	154	61	22	0368
MCL155 B		Offroad high			797	74	198	128	167	81	22	0369
MCL155 C		Offroad high			797	74	198	128	167	81	22	0369
MCL155 T		Offroad high			797	74	198	128	167	81	22	0369

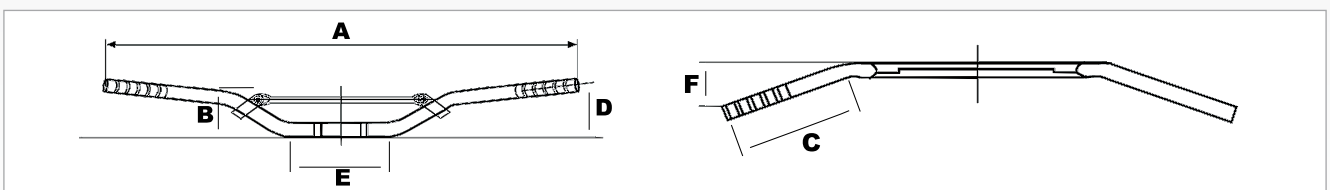

STAHLLENKER 22MM

GUIDONS ACIER

STEEL HANDLEBARS

» für viele Modelle mit ABE

- » hochwertige Stahllenkern
„made in Germany“
- » keine Eintragung vom TÜV notwendig
- » interessante Auswahl an Oberflächen:
Chrom, Alu-Look, schwarz
- » 3-faches Beschichtungsverfahren
verhindert Korrosion
- » die attraktive Formgebung ermöglicht
individuelle Optik
- » große Auswahl an verschiedenen
„Superbike“ Lenkertypen
- » zur Arretierung der Armatur kann
eine Bohrung angebracht werden

» with TÜV approval

- » high-quality, “made in Germany”
steel handlebar
- » TÜV registration not required
- » attractive selection of surface designs:
chrome, aluminium effect, black
- » 3-part coating procedure
prevents corrosion
- » attractive shape enables
individual optics
- » wide selection of different
“Superbike” handlebar types
- » a hole can be made to lock the fitting

» avec homologation TÜV

- » guidon acier haute qualité
« fabriqué en Allemagne »
- » aucun enregistrement auprès
de la TÜV nécessaire
- » choix intéressant de surfaces :
chromé, type alu, noir
- » revêtement triple anti-corrosion
- » la forme attractive permet une
esthétique individuelle
- » grand choix de guidons différents
de type « Superbike »
- » un alésage peut être ajouté pour
le blocage de l'armature



BESTEL LHINWEIS

CONSEILS POUR LA COMMANDE
ORDERING INSTRUCTIONS

ACHTUNG! CAUTION! ATTENTION!
Bitte die gewünschte Farbe ergänzen.
Please indicate required colour.
Veuillez indiquer la couleur souhaitée.



		
SC: Stahl, verchromt <i>steel, chrome plated</i> <i>acier avec finition chromée</i>	SA: Stahl, Alu-Look <i>steel, aluminium look</i> <i>acier avec aspect couleur aluminium</i>	SS: Stahl, schwarz <i>black steel</i> <i>acier avec aspect couleur noir</i>

SUPERBIKE, 22 MM



Speedfighter

Bestell-Nr.
Order no.
N° comm.

MCL124 SC	
MCL124 SA	
MCL124 SS	

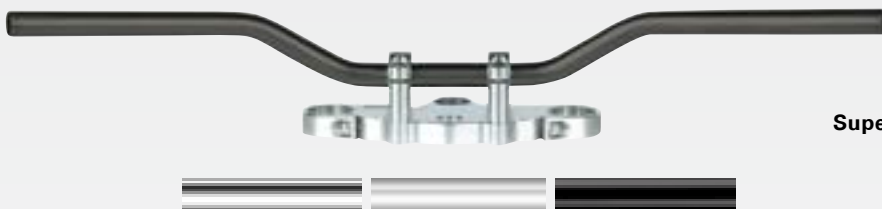

Superbike Comfort

Bestell-Nr.
Order no.
N° comm.

MCL126 SC	
MCL126 SA	
MCL126 SS	



Superbike Elegance

Bestell-Nr.
Order no.
N° comm.

MCL127 SC	
MCL127 SA	
MCL127 SS	



Superbike Sportive

Bestell-Nr.
Order no.
N° comm.

MCL128 SC	
MCL128 SA	
MCL128 SS	

TOURING, 22 MM

Bestell-Nr.
Order no.
N° comm.

MCL110 SC  **Classic High**
MCL110 SS 



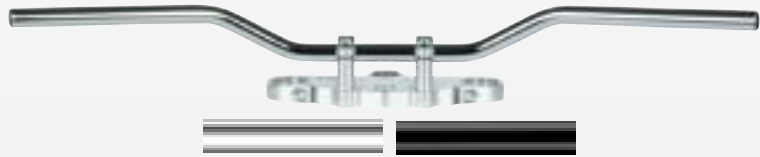

Bestell-Nr.
Order no.
N° comm.

MCL111 SC  **Classic Low**
MCL111 SS 







Bestell-Nr.
Order no.
N° comm.

MCL112 SC  **Touring High**
MCL113 SC  **Touring Low**
MCL113 SS 



Bestell-Nr.
Order no.
N° comm.

MCL121 SC  **Dragbar Long**
MCL121 SS 
MCL122 SC  **Dragbar Medium**
MCL122 SS 

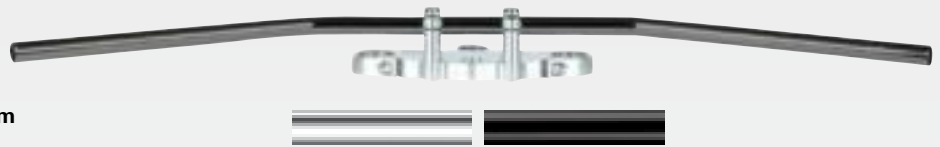

Bestell-Nr.
Order no.
N° comm.

MCL130 SC  **Mystic High**



Bestell-Nr.
Order no.
N° comm.

MCL134 SC  **Roadstar Wide**



Bestell-Nr.
Order no.
N° comm.

MCL137 SC  **Apehanger**
MCL137 SS 



CUSTOM, 22 MM

Bestell-Nr. Order no. N° comm.					A	B	C	D	E	F	Typ
MCL110	SC	SS		Classic High	810	83	240	83	130	223	01
MCL111	SC	SS		Classic Low	765	44	205	44	170	115	02
MCL112	SC			Touring High	770	126,4	220	126,4	170	224	03
MCL113	SC	SS		Touring Low	770	132	215	132	170	165	04
MCL121	SC	SS		Dragbar Long	895	0	290	0	346	149	05
MCL122	SC	SS		Dragbar Medium	800	0	240	0	336	113	06
MCL124	SC	SS	SA	Speedfighter	860	42	240	42	170	103	08
MCL126	SC	SS	SA	Superbike Comfort	720	58	200	58	140	165	09
MCL127	SC	SS	SA	Superbike Elegance	755	42	220	42	130	140	10
MCL128	SC	SS	SA	Superbike Sportive	760	31	205	31	140	94	11
MCL130	SC			Mystic High	905	130	240	130	240	191	12
MCL134	SC			Roadstar Wide	960	46	295	46	190	236	14
MCL137	SC	SS		Apehanger	830	226	190	226	180	137	16

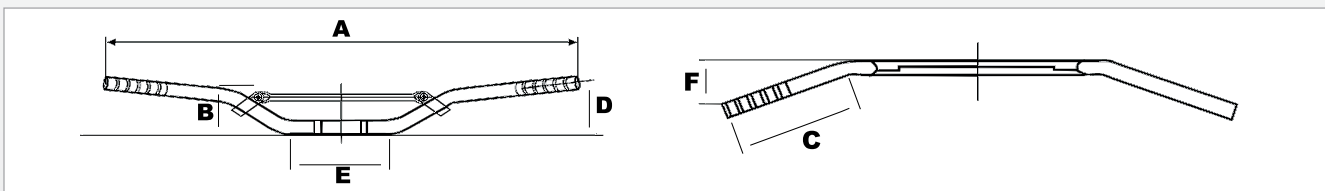

ZUBEHÖR ACCESSOIRES ACCESSORIES



Bestell-Nr. Order no. N° comm.	Lenkerenden (2 Stück) Handlebar ends (2 pieces) Embouts pour guidons (2 pièces)
MCL217 SC	
MCL217 SA	
MCL217 SS	





STAHLLENKER 1 ZOLL (25,4 MM) GUIDONS ACIER 1 POUCE STEEL HANDLEBARS 1 INCH

» mit ABE, keine Eintragung nötig

- » attraktives Design für stilgerechte Optik
- » gutes Lenkverhalten durch ausgereifte Formen
- » individuelles Outfit beginnt schon beim Lenkerumbau
- » Lenkerwechsel ermöglicht bequemere Sitzposition
- » hochwertigste Oberflächenbehandlungen
- » 3-fach-Spezialbeschichtung verhindert Korrosion
- » keine matten Chromstellen an den Biegepunkten
- » Stahlrohre von hoher Güte

» with TÜV approval

- » attractive design adds style
- » good steering response through fully-developed design
- » customising begins with the handlebars
- » changing the handlebar allows a more comfortable sitting position
- » top quality surface treatments
- » triple special coating prevents corrosion
- » no matt chrome on the bends
- » high quality steel tubes

» avec homologation TÜV

- » design attirant et donnant du style
- » bon maintien du guidon grâce à des formes sophistiquées
- » une apparence personnalisée commence d'abord par la forme du guidon
- » le changement de guidon permet une position assise plus confortable
- » traitement de surface supérieur 3 couches spéciales anti-corrosion
- » pas de marques de chrome mat aux points de flexion
- » tubes en acier de la meilleure qualité

3 STYLES

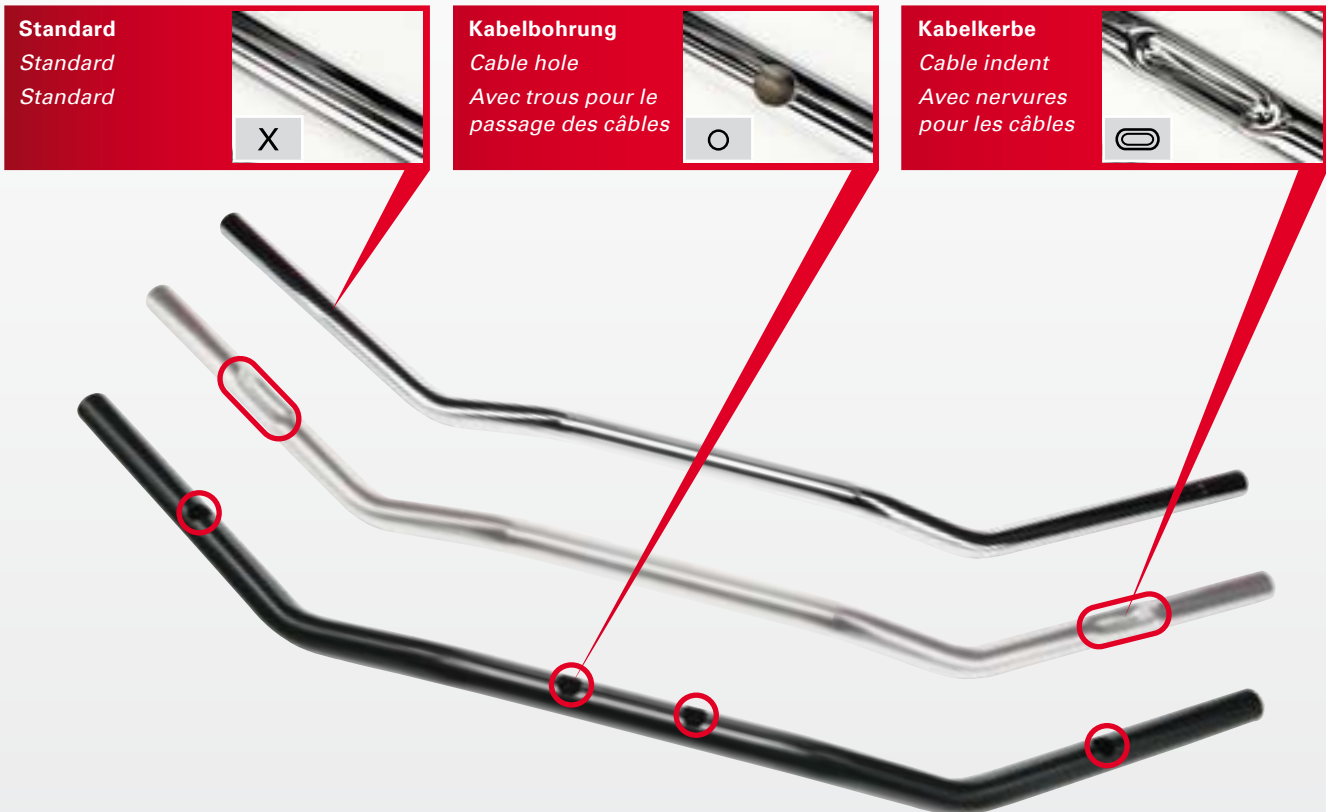

3 FARBEN 3 COULEURS
3 COLOURS

Style			
X	SC: Stahl, verchromt steel, chrome plated acier avec finition chromée	SA: Stahl, Alu-Look steel, aluminium look acier avec aspect couleur aluminium	SS: Stahl, schwarz black steel acier avec aspect couleur noir
	CKK: Stahl, verchromt mit Kabelkerben steel, chrome plated with cable indent acier avec nervures pour passage des câbles avec finition chromée	AKK: Alu-Look mit Kabelkerben aluminium look with cable indent acier avec nervures pour passage de câble et aspect couleur aluminium	SKK: schwarz mit Kabelkerben black with cable indent acier avec nervures pour passage de câble et aspect couleur noir
	CKB: Stahl, verchromt mit Kabelbohrungen steel, chrome plated with cable holes acier avec les trous pour câbles percés avec finition chromée		ACHTUNG! CAUTION! ATTENTION! Bitte gewünschte Farbe ergänzen. Please indicate required colour. Veuillez indiquer la couleur souhaitée.



Dragbar Long	MCL120 ...	X		○	X		○
Dragbar Medium	MCL123 ...	SC	CKK	CKB	SS	SKK	



Speedfighter		X		○	X		○
	MCL125 ...	SC	CKK		SA	AKK	
					SS	SKK	



Mystic		X		○	X		○
	MCL131 ...	SC	CKK		SS	SKK	



Flyerbar		X		○	X		○
	MCL132 ...	SC	CKK	CKB	SS	SKK	



Roadstar Wide		X		○	X		○
	MCL133 ...	SC	CKK		SS	SKK	



	<input checked="" type="checkbox"/>	<input type="checkbox"/>	<input type="checkbox"/>	<input checked="" type="checkbox"/>	<input type="checkbox"/>	<input type="checkbox"/>
Roadstar Medium	X		○	X		○
MCL135 ...	SC	CKK		SS	SKK	



	<input checked="" type="checkbox"/>	<input type="checkbox"/>	<input type="checkbox"/>	<input checked="" type="checkbox"/>	<input type="checkbox"/>	<input type="checkbox"/>
Apehanger	X		○	X		○
MCL136 ...	SC	CKK		SS	SKK	

Bestell-Nr. Order no. N° comm.		Style						A	B	C	D	E	F	Typ
MCL120	Dragbar long	SC	SS		CKK	SKK	CKB	900	0	290	0	300	182	05
MCL123	Dragbar medium	SC	SS		CKK	SKK		795	0	235	0	290	132	06
MCL125	Speedfighter	SC	SS	SA	CKK	SKK	AKK	860	42	240	42	170	106	08
MCL131	Mystic	SC	SS		CKK	SKK		905	140	220	140	240	178	12
MCL132	Flyerbar	SC	SS		CKK	SKK	CKB	970	42	270	42	200	180	13
MCL133	Roadstar wide	SC	SS		CKK	SKK		965	49	290	49	190	238	14
MCL135	Roadstar medium	SC	SS		CKK	SKK		900	86	280	86	190	306	15
MCL136	Apehanger	SC	SS		CKK	SKK		920	220	235	220	170	147	16

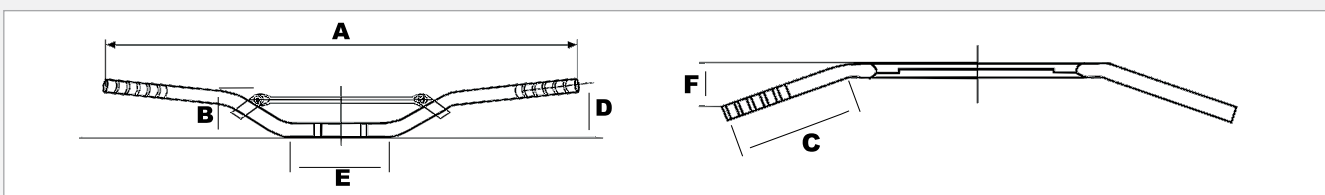

STUMMELLENKER

GUIDON BRACELET
CLIP-ONS

RACING RACING
RACING



Lieferung als Set inklusive Lenkrohr und Lenkerstopfen.

Delivery as a set, including handlebar tube and handlebar plug.

Fourni sous forme de kit avec tube de guidon et embouts.

Ø	Bestell-Nr. Order no. N° comm.
45 mm	MCL45 EC
50 mm	MCL50 EC
53 mm	MCL53 EC
55 mm	MCL55 EC

5,5° KRÖPFUNG

5.5° OFFSET

COUDAGE A 5,5°

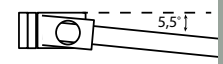

RACING – Stummel mit TÜV Gutachten

- » hightech Produkt „made in Germany“
- » hochwertiger Aluminiumlenker für den sportlichen Einsatz
- » Höhe der Klemmschelle 32 mm
- » Winkel der Lenkrohr-Kröpfung = 5,5°
- » extrem leichtgewichtig mit nur 660 g
- » schwarz eloxiert, inkl. Lenkrohre (250 mm lang) und Lenkerstopfen
- » Ausführung der Klemmschelle in 45, 50, 53 und 55 mm Durchmesser
- » Anwendung bei anderen Gabeldurchmessern mittels Distanzhülsen (siehe Seite 5.33)

RACING – clip-ons with TÜV approval

- » hightech Product „made in Germany“
- » high-grade aluminium handle bars for sportive riding
- » height of the clamp 32 mm
- » angle of the handle bar tube offset = 5.5°
- » extremely lightweight at only 660 g
- » anodised in black, incl. handlebar tubes (250 mm long) and handlebar plugs
- » 45, 50, 53 and 55 mm clamp diameter options
- » use with other fork diameters using spacer sleeves (see page 5.33)

RACING – guidon bracelet avec homologation TÜV

- » produit hightech «fabriqué en Allemagne»
- » guidon en aluminium de qualité supérieure pour le sport
- » hauteur du collier de serrage 32 mm
- » angle du coude du guidon = 5,5°
- » extrêmement léger avec seulement 660 g
- » anodisé noir, y compris les tubes (250 mm de longueur) et les embouts de guidon
- » modèles de collier de serrage en 45, 50, 53 et 55 mm de diamètre
- » utilisation pour d'autres diamètres de fourche au moyen de douilles d'écartement (voir page 5.33)

RACING-SP SP RACING

RACING-SP



NEU! NEW! NOUVEAU!

Lieferung als Set inklusive Lenkrohr und Lenkerstopfen.

Delivery as a set, including handlebar tube and handlebar plug.

Fourni sous forme de kit avec tube de guidon et embouts.

Ø	Bestell-Nr. Order no. N° comm.
45 mm	MCL45 RAC-S
50 mm	MCL50 RAC-S
53 mm	MCL53 RAC-S
55 mm	MCL55 RAC-S

5,5° KRÖPFUNG

5.5° OFFSET

COUDAGE A 5,5°

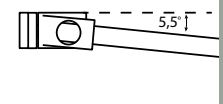

HEAVY DUTY RACING – Stummel mit TÜV Gutachten





- » High tech Produkt „made in Germany“
- » besonders stabile Konstruktion, dennoch leichter als die meisten Originallenker
- » einfacher Wechsel der Lenkrohre, zum Beispiel nach einem Sturz
- » attraktives Finish, schwarz eloxiert
- » Klemmschellendurchmesser 45, 50, 53 und 55 mm
- » Verwendung bei anderen Gabeldurchmessern mittels Distanzhülsen
- » längere Lenkrohre (285 mm) in mehreren Farben optional erhältlich







HEAVY DUTY RACING – clip-ons with TÜV certificate

- » high tech product “made in Germany”
- » particularly robust design, yet still lighter than most original handlebars
- » easy replacement of handlebar tubes, for example after a crash
- » attractive finish, black anodised
- » clamp diameter 45, 50, 53 and 55 mm
- » can be used with other fork diameters using spacer sleeves
- » longer handlebars (285 mm) optionally available in several colours

GUIDON BRACELET HEAVY DUTY – avec homologation TÜV

- » Produit haute technologie « made in Germany »
- » Construction particulièrement stable, et plus légère que la plupart des guidons d'origine
- » Changement facile des demi guidons après une chute
- » belle finition, anodisé noir
- » Diamètre des colliers de serrage : 45, 50, 53 et 55 mm
- » utilisation possible sur des fourches de diamètres différents à l'aide de douilles d'écartement
- » Demi-guidons plus longs (285 mm) disponibles optionnellement en différentes couleurs

								
Aprilia								
RSV	1000	Mille	ME	98-00	53	MCL 53 EC	MCL 53 RAC-S	
RSV	1000	Mille	RP	01-03	53	MCL 53 EC	MCL 53 RAC-S	
RSV	1000	R	RP / ME	01-03	51	MCL 53 EC	MCL 53 RAC-S	MCL 51 DH
SL	1000	Falco	PA	00-05	51	MCL 53 EC	MCL 53 RAC-S	MCL 51 DH
RSV	1000	R Factory	RR	04-10	51	MCL 53 EC	MCL 53 RAC-S	MCL 51 DH
RSV4	1000	Factory	RK	10-12	51	MCL 53 EC	MCL 53 RAC-S	MCL 51 DH
RSV4	1000	Factory APRC	RK	11-14	51	MCL 53 EC	MCL 53 RAC-S	MCL 51 DH
RSV4	1000	R	RK	10	51	MCL 53 EC	MCL 53 RAC-S	MCL 51 DH
RSV4	1000	R APRC	RK	11-	51	MCL 53 EC	MCL 53 RAC-S	MCL 51 DH
RSV4	1000	RF APRC		15-	51	MCL 53 EC	MCL 53 RAC-S	MCL 51 DH
RSV4	1000	RR		15-	51	MCL 53 EC	MCL 53 RAC-S	MCL 51 DH
BMW								
HP	1000	RR	K10	13-	55	MCL 55 EC	MCL 55 RAC-S	
	1000	RR	K10	09-	55	MCL 55 EC	MCL 55 RAC-S	
S	1000	RR	K10	09-	55	MCL 55 EC	MCL 55 RAC-S	
Ducati								
	748	S, SP, SPS	748	95-00	53	MCL 53 EC	MCL 53 RAC-S	
	748		H3	00-03	53	MCL 53 EC	MCL 53 RAC-S	
	749	R, S	H5	03-07	53	MCL 53 EC	MCL 53 RAC-S	
	750	SS	750SC	91-98	50	MCL 50 EC	MCL 50 RAC-S	
	750	SS i.E.	V2	99-02	50	MCL 50 EC	MCL 50 RAC-S	
	848	, EVO	H6	08-11	53	MCL 53 EC	MCL 53 RAC-S	
	888	Strada	888 S	93-96	50	MCL 50 EC	MCL 50 RAC-S	
	900	SS	906SC	91-98	50	MCL 50 EC	MCL 50 RAC-S	
	900	SS i.E.	V1	98-02	50	MCL 50 EC	MCL 50 RAC-S	
	916	Strada, SPO, SP	916S	94-98	53	MCL 53 EC	MCL 53 RAC-S	
	916	SPS	916S	97-98	53	MCL 53 EC	MCL 53 RAC-S	
	996	SPS	H1	97-01	53	MCL 53 EC	MCL 53 RAC-S	
	998	,S	H2	01- / 01-04	53	MCL 53 EC	MCL 53 RAC-S	
	999	,S,R,Biposto	H4	02-06	53	MCL 53 EC	MCL 53 RAC-S	
	1098	,R,S	H7	07-09	53	MCL 53 EC	MCL 53 RAC-S	
	1198	,S,SPR	H7	09-11	53	MCL 53 EC	MCL 53 RAC-S	
	1199	Panigale S	H8	12-	53	MCL 53 EC	MCL 53 RAC-S	
	1199	Panigale R	H8	13-	53	MCL 53 EC	MCL 53 RAC-S	
Honda								
CBR	600	F	PC25	91-94	41	MCL 45 EC	MCL 45 RAC-S	MCL 41 DH
CBR	600	F	PC31	95-98	41	MCL 45 EC	MCL 45 RAC-S	MCL 41 DH
CBR	600	F	PC35	99-07	43	MCL 45 EC	MCL 45 RAC-S	MCL 43 DH
CBR	600	RR	PC37	03-04	45	MCL 45 EC	MCL 45 RAC-S	
CBR	600	RR	PC37	05-06	48	MCL 50 EC	MCL 50 RAC-S	MCL 48 DH
CBR	600	RR	PC40	07-	48	MCL 50 EC	MCL 50 RAC-S	MCL 48 DH
VFR	800		RC46	98-01	41	MCL 45 EC	MCL 45 RAC-S	MCL 41 DH
VFR	800		RC46	02-05	43	MCL 45 EC	MCL 45 RAC-S	MCL 43 DH
CBR	900	RR Fireblad	SC28	92-95	45	MCL 45 EC	MCL 45 RAC-S	
CBR	900	RR Fireblad	SC33	96-97	45	MCL 45 EC	MCL 45 RAC-S	
CBR	900	RR Fireblad	SC44	00-01	50	MCL 50 EC	MCL 50 RAC-S	
CBR	900	RR Fireblad	SC50	02-03	50	MCL 50 EC	MCL 50 RAC-S	
CBR	1000	Fireblade	SC57	04-07	50	MCL 50 EC	MCL 50 RAC-S	
CBR	1000	RR Fireblad	SC59	08-	50	MCL 50 EC	MCL 50 RAC-S	
CBR	1000	RR Fireblad SP	SC59	14-	53	MCL 53 EC	MCL 53 RAC-S	
CBR	1000	F Dual	SC24	93-01	41	MCL 45 EC	MCL 45 RAC-S	MCL 41 DH
VTR	1000	Firestorm	SC36	97-08	41	MCL 45 EC	MCL 45 RAC-S	MCL 41 DH
VTR	1000	SP1	SC45	00-01	50	MCL 50 EC	MCL 50 RAC-S	
VTR	1000	SP2	SC45	02-07	50	MCL 50 EC	MCL 50 RAC-S	
CBR	1100	XX Blackbird	SC35	97-08	43	MCL 45 EC	MCL 45 RAC-S	MCL 43 DH
Kawasaki								
ZXR	400		ZX400L	91-03	50	MCL 50 EC	MCL 50 RAC-S	
ZX-6R	600	Ninja	ZX600F	94-97	41	MCL 45 EC	MCL 45 RAC-S	MCL 41 DH
ZX-6R	600	Ninja	ZX600G	98-99	46	MCL 50 EC	MCL 50 RAC-S	MCL 46 DH
ZX-6R	600	Ninja	ZX600J	00-02	46	MCL 50 EC	MCL 50 RAC-S	MCL 46 DH
ZX-6RR	600	Ninja	ZX600K	03-04	50	MCL 50 EC	MCL 50 RAC-S	
ZX-6RR	600	Ninja	ZX600N	05-06	50	MCL 50 EC	MCL 50 RAC-S	
ZX-6R	600	Ninja	ZX600P	07-08	50	MCL 50 EC	MCL 50 RAC-S	
ZX-6R	600	Ninja	ZX600R	09-	51	MCL 53 EC	MCL 53 RAC-S	MCL 51 DH
ZX-6R	636	Ninja	ZX636A	02	46	MCL 50 EC	MCL 50 RAC-S	MCL 46 DH
ZX-6R	636	Ninja	ZX636B	03-04	50	MCL 50 EC	MCL 50 RAC-S	
ZX-6R	636	Ninja	ZX636C	05-06	50	MCL 50 EC	MCL 50 RAC-S	
ZX-7R	750		ZX750P	96-02	52	MCL 53 EC	MCL 53 RAC-S	MCL 52 DH
ZXR	750	Ninja	ZX750K/L/M	92-95	52	MCL 53 EC	MCL 53 RAC-S	MCL 52 DH
ZX-9R	900	Ninja	ZX900B	94-97	52	MCL 53 EC	MCL 53 RAC-S	MCL 52 DH
ZX-9R	900	Ninja	ZX900C	98-00	46	MCL 50 EC	MCL 50 RAC-S	MCL 46 DH
ZX-9R	900	Ninja	ZX900E	01-04	46	MCL 50 EC	MCL 50 RAC-S	MCL 46 DH
Z	1000		ZRT 00 A	03-06	50	MCL 50 EC	MCL 50 RAC-S	
ZX-10R	1000	Ninja	ZXT00C	04-05	50	MCL 50 EC	MCL 50 RAC-S	
ZX-10R	1000	Ninja	ZXT00D	06-07	50	MCL 50 EC	MCL 50 RAC-S	
ZX-10R	1000	Ninja	ZXT00E	08-09	50	MCL 50 EC	MCL 50 RAC-S	
ZX-10R	1000	Ninja	ZXT00F	10-11	50	MCL 50 EC	MCL 50 RAC-S	
ZX-10R	1000	Ninja	ZXT00J	10-	50	MCL 50 EC	MCL 50 RAC-S	
ZZR	1100		ZXT10D	94-01	43	MCL 45 EC	MCL 45 RAC-S	MCL 43 DH
ZZR	1200		ZXT20C	02-05	43	MCL 45 EC	MCL 45 RAC-S	MCL 43 DH
ZZR	1400		ZXT40A	06-07	43	MCL 45 EC	MCL 45 RAC-S	MCL 43 DH

								
ZZR	1400		ZXT40C	08-11	43	MCL 45 EC	MCL 45 RAC-S	MCL 43 DH
ZZR	1400		ZXT40E	12-	43	MCL 45 EC	MCL 45 RAC-S	MCL 43 DH
KTM								
RC	390			14-	43	MCL 45 EC	MCL 45 RAC-S	MCL 43 DH
RC8	1190	R		09-	43	MCL 45 EC	MCL 45 RAC-S	MCL 43 DH
MV Augusta								
F3	675			15	50	MCL 50 EC	MCL 50 RAC-S	
F3	800			14-	50	MCL 50 EC	MCL 50 RAC-S	
Suzuki								
RGV	250		VJ22A	91-92	50	MCL 50 EC	MCL 50 RAC-S	
GSX-R	600		AD	97-00	45	MCL 45 EC	MCL 45 RAC-S	
GSX-R	600		VVVBG	01-03	45	MCL 45 EC	MCL 45 RAC-S	
GSX-R	600		VVVB2	04-05	50	MCL 50 EC	MCL 50 RAC-S	
GSX-R	600		VVCE	06-07	50	MCL 50 EC	MCL 50 RAC-S	
GSX-R	600		VWCV	08-10	50	MCL 50 EC	MCL 50 RAC-S	
GSX-R	600		C3	11-	50	MCL 50 EC	MCL 50 RAC-S	
SV	650	S	AV111	99-02	41	MCL 45 EC	MCL 45 RAC-S	MCL 41 DH
SV	650	S	VVBY	03-09	41	MCL 45 EC	MCL 45 RAC-S	MCL 41 DH
GSX-R	750		GR7AB	90-91	50	MCL 50 EC	MCL 50 RAC-S	
GSX-R	750		GR7BB	92-95	50	MCL 50 EC	MCL 50 RAC-S	
GSX-R	750		GR7DB	96-99	50	MCL 50 EC	MCL 50 RAC-S	
GSX-R	750		VVBD	00-03	50	MCL 50 EC	MCL 50 RAC-S	
GSX-R	750		VVB3	04-05	50	MCL 50 EC	MCL 50 RAC-S	
GSX-R	750		VVCF	06-07	50	MCL 50 EC	MCL 50 RAC-S	
GSX-R	750		VWCW	08-10	50	MCL 50 EC	MCL 50 RAC-S	
GSX-R	750		C4	11-	50	MCL 50 EC	MCL 50 RAC-S	
GSX-R	750		GR7DB	97-99	50	MCL 50 EC	MCL 50 RAC-S	
RF	900	R	GT73B	94-97	43	MCL 45 EC	MCL 45 RAC-S	MCL 43 DH
GSX-R	1000		VVBL	01-02	50	MCL 50 EC	MCL 50 RAC-S	
GSX-R	1000		VVBZ	03-04	50	MCL 50 EC	MCL 50 RAC-S	
GSX-R	1000		VVB6	05-06	50	MCL 50 EC	MCL 50 RAC-S	
GSX-R	1000		VVCL	07-08	50	MCL 50 EC	MCL 50 RAC-S	
GSX-R	1000		VVVCY	09-	50	MCL 50 EC	MCL 50 RAC-S	
SV	1000	,S,N	VVBX	03-08	50	MCL 50 EC	MCL 50 RAC-S	
GSX-R	1100		GV73C	90-92	52	MCL 53 EC	MCL 53 RAC-S	MCL 52 DH
GSX-R	1100	W	GU75C	93-97	52	MCL 53 EC	MCL 53 RAC-S	MCL 52 DH
GSX-R	1100	W	GU75C	95-96	50	MCL 50 EC	MCL 50 RAC-S	
SV	1000	S	VVBX	03-08	46	MCL 50 EC	MCL 50 RAC-S	MCL 46 DH
TL	1000	S	AG111	97-01	50	MCL 50 EC	MCL 50 RAC-S	
TL	1000	R	AM321	98-02	50	MCL 50 EC	MCL 50 RAC-S	
GSX-R	1100	W	GU75C	93-97	50	MCL 50 EC	MCL 50 RAC-S	
GSX-R	1300	R Hayabusa	VVA1	05-07	50	MCL 50 EC	MCL 50 RAC-S	
GSX-R	1300	R Hayabusa	VVCK	08-12	50	MCL 50 EC	MCL 50 RAC-S	
Triumph								
	600	Daytona	806 LW	03-04	43	MCL 45 EC	MCL 45 RAC-S	MCL 43 DH
	600	Speed Four	806LB	02-05	43	MCL 45 EC	MCL 45 RAC-S	MCL 43 DH
	650	Daytona	865 LX	05	43	MCL 45 EC	MCL 45 RAC-S	MCL 43 DH
	675	Daytona	D67LC	06-12	50	MCL 50 EC	MCL 50 RAC-S	
	675	Daytona	H67	13-	50	MCL 50 EC	MCL 50 RAC-S	
	900	Speed Triple	T300B	94-96	43	MCL 45 EC	MCL 45 RAC-S	MCL 43 DH
	900	Speed Triple	T509	97-98	43	MCL 45 EC	MCL 45 RAC-S	MCL 43 DH
	900	Thrupton	986ME	04-	41	MCL 45 EC	MCL 45 RAC-S	MCL 41 DH
	955	Daytona	T595	96-01	45	MCL 45 EC	MCL 45 RAC-S	
	955	Daytona	595N	02-04	50	MCL 50 EC	MCL 50 RAC-S	
	1000	Daytona	T300	92	43	MCL 45 EC	MCL 45 RAC-S	MCL 43 DH
	1200	Daytona	T300,D	93-97	43	MCL 45 EC	MCL 45 RAC-S	MCL 43 DH
Yamaha								
FZR	600		3HE	89-93	41	MCL 45 EC	MCL 45 RAC-S	MCL 41 DH
FZR	600		3RG	89-93	41	MCL 45 EC	MCL 45 RAC-S	MCL 41 DH
FZR	600		3RH	89-93	41	MCL 45 EC	MCL 45 RAC-S	MCL 41 DH
FZR	600	R	4JH	94-95	41	MCL 45 EC	MCL 45 RAC-S	MCL 41 DH
FZR	600	R	4MH	94-95	41	MCL 45 EC	MCL 45 RAC-S	MCL 41 DH
YZF	600	Thunder Cat	4TV,4WD	96-02	41	MCL 45 EC	MCL 45 RAC-S	MCL 41 DH
YZF	600	R6	RJ03	99-02	43	MCL 45 EC	MCL 45 RAC-S	MCL 43 DH
YZF	600	R6	RJ05	03	43	MCL 45 EC	MCL 45 RAC-S	MCL 43 DH
YZF	600	R6	RJ09	04-05	50	MCL 50 EC	MCL 50 RAC-S	
YZF	600	R6	RJ11	06	50	MCL 50 EC	MCL 50 RAC-S	
YZF	600	R6	RJ15	08-	50	MCL 50 EC	MCL 50 RAC-S	
YZF	750	R	4HN	93-96	50	MCL 50 EC	MCL 50 RAC-S	
YZF	750	SP	4HT	93-98	50	MCL 50 EC	MCL 50 RAC-S	
TRX	850		4UN	96-99	41	MCL 45 EC	MCL 45 RAC-S	MCL 41 DH
FZR	1000	ex up	3LE	89-90	43	MCL 45 EC	MCL 45 RAC-S	MCL 43 DH
FZR	1000	up side d.	3LE	91-95	50	MCL 50 EC	MCL 50 RAC-S	
YZF	1000	Thunder Ace	4VD	96-02	48	MCL 50 EC	MCL 50 RAC-S	MCL 48 DH
YZF	1000	R1	RN01	98-00	50	MCL 50 EC	MCL 50 RAC-S	
YZF	1000	R1	RN04	01	50	MCL 50 EC	MCL 50 RAC-S	
YZF	1000	R1	RN09	02-03	50	MCL 50 EC	MCL 50 RAC-S	
YZF	1000	R1,SP	RN12	04-06	50	MCL 50 EC	MCL 50 RAC-S	
YZF	1000	R1	RN19	07-08	50	MCL 50 EC	MCL 50 RAC-S	
YZF	1000	R1	RN22	09-	50	MCL 50 EC	MCL 50 RAC-S	
YZF	1000	R1	RN32	15-	50	MCL 50 EC	MCL 50 RAC-S	
FJ	1200	A	3YA	91-95	41	MCL 45 EC	MCL 45 RAC-S	MCL 41 DH

KOMPLETT-KITS IN 3 HÖHEN

KITS COMPLETS EN 3 HAUTEURS

COMPLETE KITS IN 3 HEIGHTS



RELAX 60

60 MM ERHÖHUNG
60 MM RISE
60 MM AUGMENTATION

4° KRÖPFUNG

4° OFFSET

COUDAGE A 4°

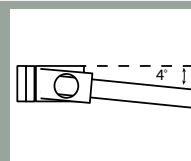

RELAX 40

40 MM ERHÖHUNG
40 MM RISE
40 MM AUGMENTATION

4° KRÖPFUNG

4° OFFSET

COUDAGE A 4°

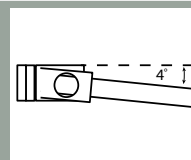

KOMFORT 20

20 MM ERHÖHUNG
20 MM RISE
20 MM AUGMENTATION

5,5° KRÖPFUNG

5.5° OFFSET

COUDAGE A 5,5°

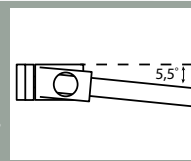

Erhöhte Lenkerstummel Kits – All in one

- » Komplettpaket inkl. Schellen, Erhöhungen und Lenkerrohre, nur Distanzhülsen und Lenkrohrstopfen müssen separat bestellt werden
- » hochwertige Ausführung aus Alu in attraktivem Design in schwarz oder silber
- » entspannte Griffhaltung entlastet die Handgelenke
- » Montage über der Gabelbrücke möglich
- » bei vielen Modellen ist die Beibehaltung des Verkleidungsoberteils möglich
- » Wechsel zum Originalzustand möglich
- » passend für viele Motorräder durch die Vielfalt der Distanzhülsen
- » Verfügbarer Klemmschellen-Durchmesser bei Komfort 20: 45 mm, 50 mm, 53 mm
- » Verfügbarer Klemmschellen-Durchmesser bei Relax 40 und 60: 45 mm und 50 mm

Raised clip-on kits – all in one

- » complete kit including clamps, risers and handlebars, only spacer sleeves and handlebar plugs have to be ordered separately
- » high quality version made of aluminium with attractive black or silver design
- » relaxed grip position takes the strain off your wrists
- » installation possible above the yoke
- » on many models the upper fairing can be retained
- » reverting back to the original state possible
- » fits a wide range of motorcycles due to different spacer sleeves
- » available clamp diameter for Comfort 20: 45 mm, 50 mm, 53 mm
- » available clamp diameter for Relax 40 and 60: 45 mm and 50 mm

Kits de guidon bracelets surélevés

- » Kit complet comprenant demi-guidons, rehausseurs et bagues de fixation, seuls les douilles d'écartement et embouts de guidon doivent être commandés séparément.
- » Modèle haut de gamme en aluminium, beau design en noir ou argent
- » une position de conduite améliorée. La pression sur les poignets est réduite
- » Montage possible sur le té de fourche
- » sur de nombreux modèles, la partie supérieure du carénage peut être conservée.
- » un retour à l'état d'origine est possible
- » convient pour de nombreuses motos grâce à la grande variété de douilles d'écartement
- » diamètres de bagues de serrage disponibles pour Komfort 20 : 45 mm, 50 mm, 53 mm
- » diamètres de bagues de serrage disponibles pour la Relax 40 et 60 : 45 mm et 50 mm

NEU! NEW! NOUVEAU!



Lieferung als Kit inklusive Schellen, Erhöhungen und Lenkrohr.
Delivery as a kit including clamps, risers and handlebar tubes.
Livré sous forme de kit, avec bagues de serrage, rehausseurs et demi guidon.



Lenkrohrstopfen aus Teflon (2 Stück)
Handlebar plugs from (2 pieces)
Embouts pour guidon, Téflon (2 pièces)

Bestell-Nr. / Order no. / N° comm.
MCL300 W <input type="checkbox"/>
MCL300 S <input type="checkbox"/>



Lenkrohrstopfen aus Alu (2 Stück)
Handlebar plugs from aluminium (2 pieces)
Embouts pour guidon, aluminium (2 pièces)





Bestell-Nr. / Order no. / N° comm.
MCL310 C <input type="checkbox"/>
MCL310 S <input type="checkbox"/>







Distanzhülsen zur Anpassung an verschiedene Gabeldurchmesser (2 Stück)
Spacers for adapting to different fork diameters (2 pieces)

Douilles d'écartement pour l'adaptation à différents diamètres de fourche (2 pièces)



Ø
38 mm
41 mm
43 mm
46 mm
48 mm
51 mm
52 mm

						I 20 mm	I 40 mm	I 60 mm	
Aprilia									
RSV	1000	Mille	ME	98-00	53	MCL 532			
RSV	1000	Mille	RP	01-03	53	MCL 532			
RSV	1000	R	RP / ME	01-03	51	MCL 532			MCL 51 DH
SL	1000	Falco	PA	00-05	51	MCL 532			MCL 51 DH
RSV	1000	R Factory	RR	04-10	51	MCL 532			MCL 51 DH
RSV4	1000	Factory	RK	10-12	51	MCL 532			MCL 51 DH
RSV4	1000	Factory APRC	RK	11-14	51	MCL 532			MCL 51 DH
RSV4	1000	R	RK	10	51	MCL 532			MCL 51 DH
RSV4	1000	R APRC	RK	11-	51	MCL 532			MCL 51 DH
RSV4	1000	RF APRC		15-	51	MCL 532			MCL 51 DH
RSV4	1000	RR		15-	51	MCL 532			MCL 51 DH
Ducati									
	748	S, SP, SPS	748	95-00	53	MCL 532			
	748		H3	00-03	53	MCL 532			
	749	R, S	H5	03-07	53	MCL 532			
	750	SS	750SC	91-98	50	MCL 502	MCL 504	MCL 506	
	750	SS i.E.	V2	99-02	50	MCL 502	MCL 504	MCL 506	
	848	, EVO	H6	08-11	53	MCL 532			
	888	Strada	888 S	93-96	50	MCL 502	MCL 504	MCL 506	
	900	SS	906SC	91-98	50	MCL 502	MCL 504	MCL 506	
	900	SS i.E.	V1	98-02	50	MCL 502	MCL 504	MCL 506	
	916	Strada, SPO, SP	916S	94-98	53	MCL 532			
	916	SPS	916S	97-98	53	MCL 532			
	996	SPS	H1	97-01	53	MCL 532			
	998	,S	H2	01- / 01-04	53	MCL 532			
	999	,S,R,Biposto	H4	02-06	53	MCL 532			
	1098	,R,S	H7	07-09	53	MCL 532			
	1198	,S,SPR	H7	09-11	53	MCL 532			
	1199	Panigale S	H8	12-	53	MCL 532			
	1199	Panigale R	H8	13-	53	MCL 532			
Honda									
CBR	600	F	PC25	91-94	41	MCL 452	MCL 454	MCL 456	MCL 41 DH
CBR	600	F	PC31	95-98	41	MCL 452	MCL 454	MCL 456	MCL 41 DH
CBR	600	F	PC35	99-07	43	MCL 452	MCL 454	MCL 456	MCL 43 DH
CBR	600	RR	PC37	03-04	45	MCL 452	MCL 454	MCL 456	
CBR	600	RR	PC37	05-06	48	MCL 452	MCL 454	MCL 456	MCL 48 DH
CBR	600	RR	PC40	07-	48	MCL 452	MCL 454	MCL 456	MCL 48 DH
VFR	800		RC46	98-01	41	MCL 452	MCL 454	MCL 456	MCL 41 DH
VFR	800		RC46	02-05	43	MCL 452	MCL 454	MCL 456	MCL 43 DH
CBR	900	RR Fireblade	SC28	92-95	45	MCL 452	MCL 454	MCL 456	
CBR	900	RR Fireblade	SC33	96-97	45	MCL 452	MCL 454	MCL 456	
CBR	900	RR Fireblade	SC44	00-01	50	MCL 502	MCL 504	MCL 506	
CBR	900	RR Fireblade	SC50	02-03	50	MCL 502	MCL 504	MCL 506	
CBR	1000	RR Fireblade	SC57	04-07	50	MCL 502	MCL 504	MCL 506	
CBR	1000	RR Fireblade	SC59	08-	50	MCL 502	MCL 504	MCL 506	
CBR	1000	RR Fireblade SP	SC59	14-	53	MCL 532			
CBR	1000	F Dual	SC24	93-01	41	MCL 452	MCL 454	MCL 456	MCL 41 DH
VTR	1000	Firestorm	SC36	97-08	41	MCL 452	MCL 454	MCL 456	MCL 41 DH
VTR	1000	SP1	SC45	00-01	50	MCL 502	MCL 504	MCL 506	
VTR	1000	SP2	SC45	02-07	50	MCL 502	MCL 504	MCL 506	
CBR	1100	XX Blackbird	SC35	97-08	43	MCL 452	MCL 454	MCL 456	MCL 43 DH
Kawasaki									
ZXR	400		ZX400L	91-03	50	MCL 502	MCL 504	MCL 506	
ZX-6R	600	Ninja	ZX600F	94-97	41	MCL 452	MCL 454	MCL 456	MCL 41 DH
ZX-6R	600	Ninja	ZX600G	98-99	46	MCL 502	MCL 504	MCL 506	MCL 46 DH
ZX-6R	600	Ninja	ZX600J	00-02	46	MCL 502	MCL 504	MCL 506	MCL 46 DH
ZX-6RR	600	Ninja	ZX600K	03-04	50	MCL 502	MCL 504	MCL 506	
ZX-6RR	600	Ninja	ZX600N	05-06	50	MCL 502	MCL 504	MCL 506	
ZX-6R	600	Ninja	ZX600P	07-08	50	MCL 502	MCL 504	MCL 506	
ZX-6R	600	Ninja	ZX600R	09-	51	MCL 532			MCL 51DH
ZX-6R	636	Ninja	ZX636A	02	46	MCL 502	MCL 504	MCL 506	MCL 46 DH
ZX-6R	636	Ninja	ZX636B	03-04	50	MCL 502	MCL 504	MCL 506	
ZX-6R	636	Ninja	ZX636C	05-06	50	MCL 502	MCL 504	MCL 506	
ZX-7R	750		ZX750P	96-02	52	MCL 532			MCL 52 DH
ZXR	750	Ninja	ZX750K/L/M	92-95	52	MCL 532			MCL 52 DH
ZX-9R	900	Ninja	ZX900B	94-97	52	MCL 532			MCL 52 DH
ZX-9R	900	Ninja	ZX900C	98-00	46	MCL 502	MCL 504	MCL 506	MCL 46 DH
ZX-9R	900	Ninja	ZX900E	01-04	46	MCL 502	MCL 504	MCL 506	MCL 46 DH
Z	1000		ZRT 00 A	03-06	50	MCL 502	MCL 504	MCL 506	
ZX-10R	1000	Ninja	ZXT00C	04-05	50	MCL 502	MCL 504	MCL 506	
ZX-10R	1000	Ninja	ZXT00D	06-07	50	MCL 502	MCL 504	MCL 506	
ZX-10R	1000	Ninja	ZXT00E	08-09	50	MCL 502	MCL 504	MCL 506	
ZX-10R	1000	Ninja	ZXT00F	10-11	50	MCL 502	MCL 504		
ZX-10R	1000	Ninja	ZXT00J	10-	50	MCL 502	MCL 504		
ZZR	1100		ZXT10D	94-01	43	MCL 452	MCL 454	MCL 456	MCL 43 DH
ZZR	1200		ZXT20C	02-05	43	MCL 452	MCL 454	MCL 456	MCL 43 DH
ZZR	1400		ZXT40A	06-07	43	MCL 452	MCL 454	MCL 456	MCL 43 DH
ZZR	1400		ZXT40C	08-11	43	MCL 452	MCL 454	MCL 456	MCL 43 DH
ZZR	1400		ZXT40E	12-	43	MCL 452	MCL 454	MCL 456	MCL 43 DH
KTM									
RC	390			14-	43	MCL 452	MCL 454	MCL 456	MCL 43 DH

						I 20 mm	I 40 mm	I 60 mm	
RC8	1190	R		09-	43	MCL 452	MCL 454	MCL 456	MCL 43 DH
MC Augusta									
F3	675			15	50	MCL 502			
F3	800			14-	50	MCL 502			
Suzuki									
RGV	250		VJ22A	91-92	50	MCL 502	MCL 504	MCL 506	
GSX-R	600		AD	97-00	45	MCL 452	MCL 454	MCL 456	
GSX-R	600		WVBG	01-03	45	MCL 452	MCL 454	MCL 456	
GSX-R	600		WVB2	04-05	50	MCL 502	MCL 504	MCL 506	
GSX-R	600		WVCE	06-07	50	MCL 502	MCL 504	MCL 506	
GSX-R	600		WVCV	08-10	50	MCL 502	MCL 504	MCL 506	
GSX-R	600		C3	11-	50	MCL 502	MCL 504	MCL 506	
SV	650	S	AV111	99-02	41	MCL 452	MCL 454	MCL 456	MCL 41 DH
SV	650	S	WVBY	03-09	41	MCL 452	MCL 454	MCL 456	MCL 41 DH
GSX-R	750		GR7AB	90-91	50	MCL 502	MCL 504	MCL 506	
GSX-R	750		GR7BB	92-95	50	MCL 502	MCL 504	MCL 506	
GSX-R	750		GR7DB	96-99	50	MCL 502	MCL 504	MCL 506	
GSX-R	750		WVBD	00-03	50	MCL 502	MCL 504	MCL 506	
GSX-R	750		WVB3	04-05	50	MCL 502	MCL 504	MCL 506	
GSX-R	750		WVCF	06-07	50	MCL 502	MCL 504	MCL 506	
GSX-R	750		WVCW	08-10	50	MCL 502	MCL 504	MCL 506	
GSX-R	750		C4	11-	50	MCL 502	MCL 504	MCL 506	
GSX-R	750		GR7DB	97-99	50	MCL 502	MCL 504	MCL 506	
RF	900	R	GT73B	94-97	43	MCL 452	MCL 454	MCL 456	MCL 43 DH
GSX-R	1000		WVBL	01-02	50	MCL 502	MCL 504	MCL 506	
GSX-R	1000		WVBZ	03-04	50	MCL 502	MCL 504	MCL 506	
GSX-R	1000		WVB6	05-06	50	MCL 502	MCL 504	MCL 506	
GSX-R	1000		WVCL	07-08	50	MCL 502	MCL 504	MCL 506	
GSX-R	1000		WVCY	09-	50	MCL 502	MCL 504	MCL 506	
SV	1000	,S,N	WVBX	03-08	50	MCL 502	MCL 504	MCL 506	
GSX-R	1100		GV73C	90-92	52	MCL 532			MCL 52 DH
GSX-R	1100	W	GU75C	93-97	52	MCL 532			MCL 52 DH
GSX-R	1100	W	GU75C	95-96	50	MCL 502	MCL 504	MCL 506	
SV	1000	S	WVBX	03-08	46	MCL 502	MCL 504	MCL 506	MCL 46 DH
TL	1000	S	AG111	97-01	50	MCL 502	MCL 504	MCL 506	
TL	1000	R	AM321	98-02	50	MCL 502	MCL 504	MCL 506	
GSX-R	1100	W	GU75C	93-97	50	MCL 502	MCL 504	MCL 506	
GSX-R	1300	R Hayabusa	WVA1	05-07	50	MCL 502	MCL 504	MCL 506	
GSX-R	1300	R Hayabusa	WVCK	08-12	50	MCL 502	MCL 504	MCL 506	
Triumph									
	600	Daytona	806 LV	03-04	43	MCL 452	MCL 454	MCL 456	MCL 43 DH
	600	Speed Four	806LB	02-05	43	MCL 452	MCL 454	MCL 456	MCL 43 DH
	650	Daytona	865 LX	05	43	MCL 452	MCL 454	MCL 456	MCL 43 DH
	675	Daytona	D67LC	06-12	50	MCL 502	MCL 504	MCL 506	
	675	Daytona	H67	13-	50	MCL 502	MCL 504	MCL 506	
	900	Speed Triple	T300B	94-96	43	MCL 452	MCL 454	MCL 456	MCL 43 DH
	900	Speed Triple	T509	97-98	43	MCL 452	MCL 454	MCL 456	MCL 43 DH
	900	Thrupton	986ME	04-	41	MCL 452	MCL 454	MCL 456	MCL 41 DH
	955	Daytona	T595	96-01	45	MCL 452	MCL 454	MCL 456	
	955	Daytona	595N	02-04	50	MCL 502	MCL 504	MCL 506	
	1000	Daytona	T300	92	43	MCL 452	MCL 454	MCL 456	MCL 43 DH
	1200	Daytona	T300,D	93-97	43	MCL 452	MCL 454	MCL 456	MCL 43 DH
Yamaha									
FZR	600		3HE	89-93	41	MCL 452	MCL 454	MCL 456	MCL 41 DH
FZR	600		3RG	89-93	41	MCL 452	MCL 454	MCL 456	MCL 41 DH
FZR	600		3RH	89-93	41	MCL 452	MCL 454	MCL 456	MCL 41 DH
FZR	600	R	4JH	94-95	41	MCL 452	MCL 454	MCL 456	MCL 41 DH
FZR	600	R	4MH	94-95	41	MCL 452	MCL 454	MCL 456	MCL 41 DH
YZF	600	Thunder Cat	4TV,4WD	96-02	41	MCL 452	MCL 454	MCL 456	MCL 41 DH
YZF	600	R6	RJ03	99-02	43	MCL 452	MCL 454	MCL 456	MCL 43 DH
YZF	600	R6	RJ05	03	43	MCL 452	MCL 454	MCL 456	MCL 43 DH
YZF	600	R6	RJ09	04-05	50	MCL 502	MCL 504	MCL 506	
YZF	600	R6	RJ11	06	50	MCL 502	MCL 504	MCL 506	
YZF	600	R6	RJ15	08-	50	MCL 502	MCL 504	MCL 506	
YZF	750	R	4HN	93-96	50	MCL 502	MCL 504	MCL 506	
YZF	750	SP	4HT	93-98	50	MCL 502	MCL 504	MCL 506	
TRX	850		4UN	96-99	41	MCL 452	MCL 454	MCL 456	MCL 41 DH
FZR	1000	ex up	3LE	89-90	43	MCL 452	MCL 454	MCL 456	MCL 43 DH
FZR	1000	up side d.	3LE	91-95	50	MCL 502	MCL 504	MCL 506	
YZF	1000	Thunder Ace	4VD	96-02	48	MCL 502	MCL 504	MCL 506	MCL 48 DH
YZF	1000	R1	RN01	98-00	50	MCL 502	MCL 504	MCL 506	
YZF	1000	R1	RN04	01	50	MCL 502	MCL 504	MCL 506	
YZF	1000	R1	RN09	02-03	50	MCL 502	MCL 504	MCL 506	
YZF	1000	R1,SP	RN12	04-06	50	MCL 502	MCL 504	MCL 506	
YZF	1000	R1	RN19	07-08	50	MCL 502	MCL 504	MCL 506	
YZF	1000	R1	RN22	09-	50	MCL 502	MCL 504	MCL 506	
YZF	1000	R1	RN32	15-	50	MCL 502	MCL 504	MCL 506	
FJ	1200	A	3YA	91-95	41	MCL 452	MCL 454	MCL 456	MCL 41 DH

Bitte gewünschte Farbe ergänzen:
 CK  Beispiel: MCL 532 CK
 SK  Beispiel: MCL 532 SK

Please indicate colour:
 CK  Example: MCL 532 CK
 SK  Example: MCL 532 SK

Veuillez ajouter pour la couleur
 CK  Example: MCL 532 CK
 SK  Example: MCL 532 SK

FÜR INDIVIDUALISTEN

POUR LA PERSONNALISATION

FOR INDIVIDUALISTS



4 FARBEN, 2 LÄNGEN
 4 COLOURS, 2 LENGTHS
 4 COULEURS, 2 LONGUEURS

3 HÖHEN, 2 FARBEN
 3 HEIGHTS, 2 COLOURS
 3 HAUTEURS, 2 COULEURS

2 MATERIALIEN, 2 FARBEN
 2 MATERIALS, 2 COLOURS
 2 MATÉRIAUX, 2 COULEURS

Für Individualisten

- » drei verschiedene Erhöhungen in schwarz oder silber
- » Lenkerrohre in vier Farben und jeweils zwei Längen
- » Lenkerrohrstopfen in zwei verschiedenen Materialien und jeweils zwei verschiedenen Farben

For individualists

- » three different risers in black or silver
- » handlebar tubes in four colours and two lengths each
- » handlebar plugs in two different materials and two different colours each

Für Individualisten

- » trois rehausseurs différents en noir ou en argent
- » Demi-guidons en 4 couleurs et 2 longueurs
- » embouts de demi-guidons en 2 matériaux différents et 2 couleurs différentes



Klemmschellen-Set (2 Stück) mit 20 mm Erhöhung.

Clamp kit (2 pieces) with 20 mm rise.

Kit de bagues de serrage (2 pièces) avec rehausseur de 20 mm.



∅ mm	Bestell-Nr. Order no. N° comm.	
45	MCL452C	MCL452S
50	MCL502C	MCL502S
53	MCL532C	MCL532S



Basis-Set mit 2 Klemmschellen (∅ 45 oder 50 mm). Bitte Aufnahme in gewünschter Höhe separat bestellen (siehe unten).

The basic set with 2 clamps (∅ 45 or 50 mm). Please order the fitting for the required height separately (see below).

Le kit de base avec 2 fixations principales (∅ 45 ou 50 mm). Veuillez commander le logement de la hauteur souhaitée séparément (voir plus bas).



∅ mm	Bestell-Nr. Order no. N° comm.	
45	MCL45C	MCL45S
50	MCL50C	MCL50S



Lenkrohraufnahme-Set in 40 oder 60 mm Höhe.

Handlebar fitting in 40 or 60 mm height.

Ensemble de supports pour guidon en 40 ou 60 mm de hauteur.



I mm	Bestell-Nr. Order no. N° comm.	
40	MCL40LAC	MCL40LAS
60	MCL60LAC	MCL60LAS

LENKERROHRE

DEMI-GUIDONS
HANDLEBAR TUBES



Eloxierte Lenkrohre mit 3 mm Wandstärke zur Verwendung mit allen TRW Stummellenkern (1 Stück)

Anodised handlebar tubes with 3 mm material thickness for use with all TRW clip-ons (1 piece).

Demi-guidons anodisé d'une épaisseur de tube de 3 mm pour une utilisation avec tous les guidons bracelet TRW (1 pièce).

mm	Bestell-Nr. Order no. N° comm.			
250	MCL250 C	MCL250 R	MCL250 S	MCL250 B
285	MCL285 C	MCL285 R	MCL285 S	MCL285 B



Lenkrohrstopfen aus Teflon (2 Stück)
Handlebar plugs from Teflon (2 pieces)
Embouts pour guidon, Téflon (2 pièces)

Bestell-Nr. / Order no. / N° comm.	
MCL300 W	
MCL300 S	



Lenkrohrstopfen aus Alu (2 Stück)
Handlebar plugs from aluminium (2 pieces)
Embouts pour guidon, aluminium (2 pièces)

Bestell-Nr. / Order no. / N° comm.	
MCL310 C	
MCL310 S	



Distanzhülsen zur Anpassung an verschiedene Gabeldurchmesser (2 Stück)
Spacers for adapting to different fork diameters (2 pieces)

Douilles d'écartement pour l'adaptation à différents diamètres de fourche (2 pièces)

Ø
38 mm
41 mm
43 mm
46 mm
48 mm
51 mm
52 mm

SPEZIELL FÜR HARLEY DAVIDSON

CONÇU SPÉCIALEMENT POUR LES HARLEY DAVIDSON

ESPECIALLY FOR HARLEY DAVIDSON



Lieferung als Set: Schellen inkl. Rohren (285 mm) mit Kabelkerbe.

Delivery as a kit: clamps including tubes (285 mm) with cable notch.

Livraison sous forme de kit : bagues de serrage et demi-guidons (285 mm) avec passage de câble.

∅	Bestell-Nr. Set Order no. Kit N° comm. kit	
35 mm	MCL35RAC-C	MCL35RAC-S
39 mm	MCL39RAC-C	MCL39RAC-S
41 mm	MCL41RAC-C	MCL41RAC-S
49 mm	MCL49RAC-C	MCL49RAC-S

RACING-Stummel für Harley Davidson

Der beste und einfachste Weg, Custom Bikes auf den Cafe Racer – Look umzubauen. Dabei überraschend komfortabel durch die moderate Geometrie mit einem Lenkrohrwinkel von 5,5 Grad.

- » Feinste, dennoch sehr robuste CNC-Frästeile aus hochfestem Aluminium
- » Aufgeräumtes Design, perfekt an ge-cleaneten Bikes
- » Lenkrohre in 25,4 mm (1 Zoll)
- » Lenkerrohr mit und ohne Kabelkerbe verfügbar
- » Klemmschellendurchmesser in 35 mm, 39 mm, 41 mm und 49 mm
- » Attraktives Finish, schwarz und silbern eloxiert

RACING clip-ons for Harley Davidson

The best and easiest way to convert custom bikes to the café racer look. Surprisingly comfortable thanks to the moderate geometry with a handlebar angle of 5.5 degrees.

- » finest yet very robust CNC milled parts made of high strength aluminium
- » clean design, perfect on cleaned bikes
- » handlebar tubes in 25.4 mm (1 inch)
- » handlebar tubes available with and without cable notch
- » clamp diameter in 35 mm, 39 mm, 41 mm and 49 mm
- » attractive finish, black and silver anodised



GUIDON BRACELET pour Harley Davidson

Le moyen le plus simple et aisé pour donner à votre moto un look « Cafe racer », tout en étant étonnamment confortables grâce à son cintrage de guidon de 5,5°.

- » Pièces en aluminium haute résistance usinées CNC d'une finition remarquable
- » beau design, parfait sur des motos épurées
- » demi-guidons de 25,4 mm (1 pouce)
- » demi-guidons disponible avec et sans passage de câble
- » diamètres des bagues de serrage : 35 mm, 39 mm, 41 mm et 49 mm
- » belle finition, anodisé noir et argent

Rohre mit Kabelkerbe
Tubes with cable notch
Demi-guidons avec passage de câble



Rohre ohne Kabelkerbe
Tubes without cable notch
Demi-guidons sans passage de câble



H mm	Bestell-Nr. Rohre Order no. Tubes N° comm. Tube	
285	MCL254CK	MCL254SK
X 285	MCL254C	MCL254S



PERFEKTE KONTROLLE

Stahl und Alulenker von TRW. Konifiziert, in Zollgrößen oder als Standardmodell.

PERFECT CONTROL

Steel and aluminium handlebars from TRW. Conified, in inch sizes or as a standard model.

UN CONTRÔLE PARFAIT

Acier et guidon alu de TRW. Conifié, tailles en pouces ou modèle standard.





BREMS- & KUPPLUNGSHEBEL

LEVIERS DE FREINS & D'EMBAYAGE

BRAKE & CLUTCH LEVERS

BREMS- UND KUPPLUNGSHEBEL, LANG

LEVIERS DE FREINS ET D'EMBRAYAGE, LONGS

BRAKE AND CLUTCH LEVERS, LONG

Brems- und Kupplungshebel „Street“ mit ABE

- » mit CNC gefräste Hebel aus Aluminium
- » ergonomisch geformte Hebel mit **80 mm Grifflänge**
- » formschöne Leichtbauweise mit perfektem Design
- » 6-fache, kugellagerte Verstellmöglichkeit
- » Sollbruchstelle am Hebel erhöht die Sicherheit
- » gute Dosierung und exzellentes Griffgefühl
- » schwarze und silberne Hebel mit rotem Versteller
- » goldene und blaue Hebel mit schwarzem Versteller
- » Verstellstufen leicht während der Fahrt zu betätigen
- » umfangreiches Programm

“Street“ brake and clutch levers with TÜV approval

- » CNC-milled aluminium levers
- » ergonomically shaped lever with **80 mm grip length**
- » attractively shaped, lightweight construction with a perfect design
- » 6-fold adjustment on ball-bearing mount
- » predetermined breaking point on lever increases safety
- » good application and excellent handling
- » black and silver levers with red adjuster
- » gold and blue levers with black adjuster
- » adjustment stages can be easily switched whilst riding
- » comprehensive range

Leviere de freins et d'embrayage «Street» avec homologation TÜV

- » avec élément en aluminium fraisé sur CNC
- » levier ergonomique avec **poignée de 80 mm de longueur**
- » construction légère profilée au design parfait
- » 6 positions de réglage sur roulements à billes
- » position de rupture sur le levier pour plus de sécurité
- » bon dosage et excellente sensation de prise en main
- » levier noir et argenté avec sélecteur rouge
- » levier jaune et bleu avec sélecteur noir
- » facilité de réglage durant la conduite
- » programme complet

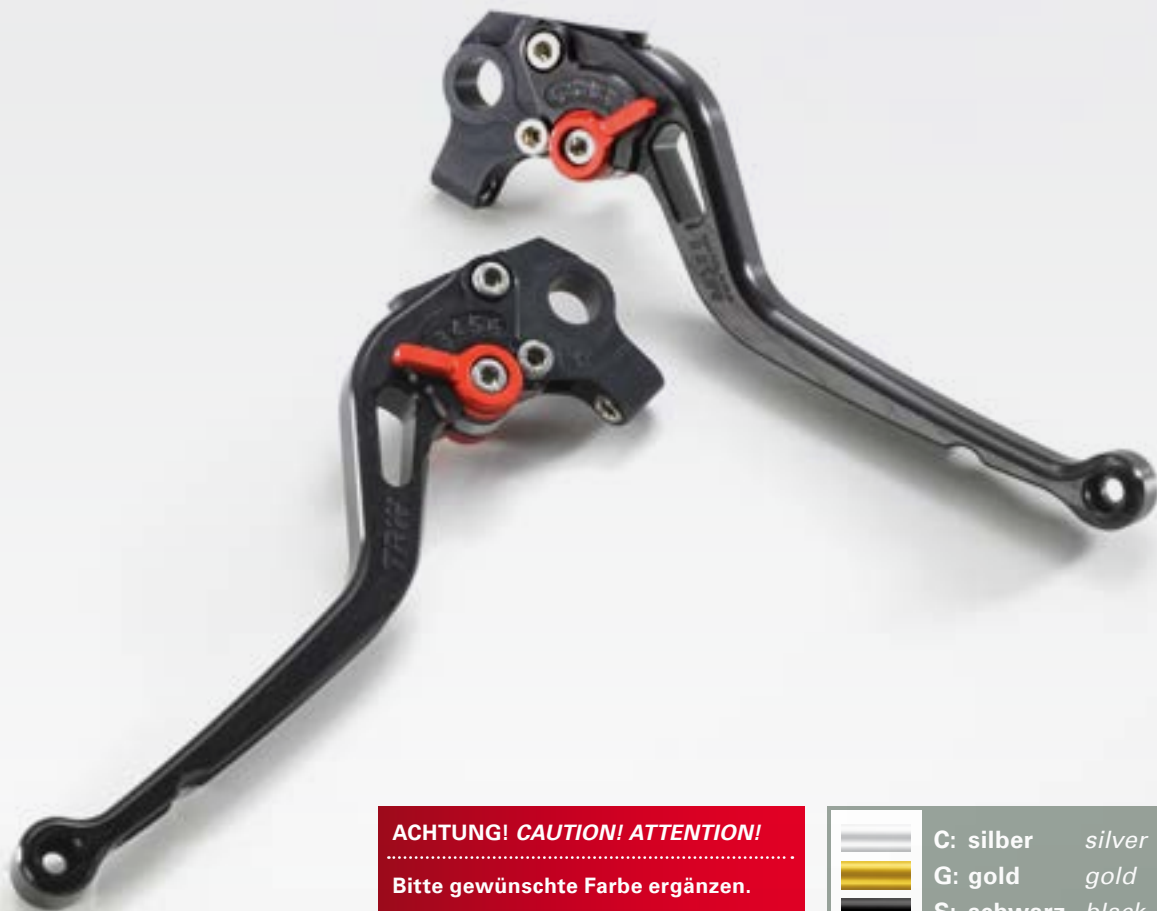

ACHTUNG! CAUTION! ATTENTION!

Bitte gewünschte Farbe ergänzen.

Please indicate required colour.

Veuillez indiquer la couleur souhaitée.

	C: silber	silver argent
	G: gold	gold or
	S: schwarz	black noir
	B: blau	blue bleu

BREMS- UND KUPPLUNGSHEBEL, KURZ

LEVIERS DE FREINS ET D'EMBRAYAGE, COURTS

BRAKE AND CLUTCH LEVERS, SHORT

Brems- und Kupplungshebel „Racing“ mit ABE

- » mit CNC gefräste Hebel aus Aluminium
- » ergonomisch geformte Hebel mit **50 mm Grifflänge**
- » formschöne Leichtbauweise mit perfektem Design
- » 6-fache, kugelgelagerte Verstellmöglichkeit
- » im internationalen Rennsport getestet
- » schwarze und silberne Hebel mit rotem Versteller
- » goldene und blaue Hebel mit schwarzem Versteller
- » exzellentes Griffgefühl für „Bremsen mit zwei Fingern“
- » umfangreiches Programm

“Racing” brake and clutch levers with TÜV approval

- » CNC-milled aluminium levers
- » ergonomically shaped lever with **50 mm grip length**
- » attractively shaped, lightweight construction with a perfect design
- » 6-fold adjustment on ball-bearing mount
- » tested in international racing
- » black and silver levers with red adjuster
- » gold and blue levers with black adjuster
- » excellent handling for 2-finger brakings
- » comprehensive range







Leviers de freins et d'embrayage « Racing » avec homologation TÜV







- » avec élément en aluminium fraisé sur CNC
- » levier ergonomique avec **poignée de 50 mm de longueur**
- » construction légère profilée au design parfait
- » 6 positions de réglage sur roulements à billes
- » test sur circuits de course internationaux
- » levier noir et argenté avec sélecteur rouge
- » levier jaune et bleu avec sélecteur noir
- » excellent prise en main pour « freiner à deux doigts »
- » programme complet















Farbe
Colour
CouleurFarbe
Colour
Couleur

Aprilia										
	750	Dorsoduro Factory ABS		10-12	MHL513	MHR513	G C S	MHL113	MHR113	G C S
ETV	1000	Caponord	PS	01-07	MHL513	MHR513	G C S	MHL113	MHR113	G C S
RSV	1000	Mille R	ME	98-00	MHL513	MHR513	G C S	MHL113	MHR113	G C S
RSV	1000	Mille R, SP	RP	01-03	MHL513	MHR513	G C S	MHL113	MHR113	G C S
RSV	1000	R, Factory	RR	04-08	MHLR525	MHRR523	G C S	MHLR125	MHRR123	G C S
	1000	Tuono	RP	02-10	MHL513	MHR513	G C S	MHL113	MHR113	G C S
	1000	Tuono R, Factory	RR	04-09	MHL513	MHR513	G C S	MHL113	MHR113	G C S
SL	1000	Falco	PA	00-05	MHL513	MHR513	G C S	MHL113	MHR113	G C S
	1200	Dorsoduro		11-12	MHL513	MHR513	G C S	MHL113	MHR113	G C S
	1200	Caponord		12-13	MHL513	MHR513	G C S	MHL113	MHR113	G C S
Bimota										
DB6	1000	Delirio		06-11	MHL513	MHR513	G C S	MHL113	MHR113	G C S
DB5	1000	S, R		06-11	MHL513	MHR513	G C S	MHL113	MHR113	G C S
DB7	1098			08-11	MHLR525	MHRR523	G C S	MHLR125	MHRR123	G C S
DB8	1198			10-11	MHLR525	MHRR523	G C S	MHLR125	MHRR123	G C S
BMW										
S	1000	RR Superbike		09-13	MHL559	MHR518	S B	MHL159	MHR118	S B
K	1200	S, R, GT		04-08	MHL537	MHR529	C S B	MHL137	MHR129	B
R	1200	R, S, ST		05-08	MHL537	MHR529	C S B	MHL137	MHR129	B
R	1200	GS, Adventure		06-08	MHL537	MHR529	C S B	MHL137	MHR129	B
	1200	HP2 Enduro		06-	MHL537	MHR529	C S B	MHL137	MHR129	B
K	1300	S, R, GT		09-	MHL537	MHR529	C S B	MHL137	MHR129	B
Buell										
XB-9R	984	Firebolt	XB1	02-08	MHL511	MHR511	G C S			
XB-9S	984	Lightning	XB1	02-08	MHL511	MHR511	G C S			
XB-1125	1125	R, RC	XB3	07-	MHL524	MHR517	G C S	MHL124	MHR117	G C S
XB-12R	1200	Firebolt	XB1	03-08	MHL511	MHR511	G C S			
XB-12S	1200	Lightning	XB2	05-08	MHL511	MHR511	G C S			
M2	1200	Cyclone	EB1	97-02	MHL511	MHR517	G C S	MHL111	MHR117	G C S
S1	1200	Lightning	EB1	97-02	MHL511	MHR517	G C S	MHL111	MHR117	G C S
X1	1200	Lightning	BL1	98-02	MHL511	MHR517	G C S	MHL111	MHR117	G C S
Ducati										
M	400	Monster	M3	98-01	MHL512	MHR512	G C S	MHL112	MHR112	G C S
M	600	Monster	M	94-98	MHL512	MHR512	G C S	MHL112	MHR112	G C S
M	600	Monster	M3	98-01	MHL512	MHR512	G C S	MHL112	MHR112	G C S
	600	SS	S	94-98	MHL512	MHR512	G C S	MHL112	MHR112	G C S
M	620	Monster i. E.	M4	01-08	MHL512	MHR512	G C S	MHL112	MHR112	G C S
	620	SS i. E.	V5	02-07	MHL513	MHR513	G C S	MHL113	MHR113	G C S
	620	Multistrada	A1	05-06	MHL513	MHR513	G C S	MHL113	MHR113	G C S
	696	Monster	M5	08-13	MHL560	MHR512	S	MHL112	MHR112	G C S
	748	S, SP	748	95-98	MHL512	MHR512	G C S	MHL112	MHR112	G C S
	748	S, SP	748	99-04	MHL513	MHR513	G C S	MHL113	MHR113	G C S
	749	, R, S	H5	02-06	MHLR525	MHRR523	G C S	MHLR125	MHRR123	G C S
	750	Monster	M	94-01	MHL512	MHR512	G C S	MHL112	MHR112	G C S
	750	Monster i. E.	M4	01-03	MHL512	MHR512	G C S	MHL112	MHR112	G C S
	750	SS	S	94-98	MHL512	MHR512	G C S	MHL112	MHR112	G C S
	796	Monster	M5	10-13	MHL560	MHR512	S			
S2R	800	Monster	M4	06-08	MHL513	MHR513	G C S	MHL113	MHR113	G C S
	848	, S	H6	09-	MHLR525	MHRR523	G C S	MHLR125	MHRR123	G C S
M	900	Monster	M	94-99	MHL512	MHR512	G C S	MHL112	MHR112	G C S
M	900	Monster i. E.	M2	99-02	MHL512	MHR512	G C S	MHL112	MHR112	G C S
M	900	Monster i. E.	M4	00-04	MHL512	MHR512	G C S	MHL112	MHR112	G C S
	900	SL, SS	S	91-98	MHL512	MHR512	G C S	MHL112	MHR112	G C S
	900	SS i. E.	V1	98-06	MHL513	MHR513	G C S	MHL113	MHR113	G C S

							Farbe Colour Couleur			Farbe Colour Couleur
M	916	Monster S4	M4	01-06	MHL513	MHR513	G C S	MHL113	MHR113	G C S
	916	Biposto	916	94-97	MHL512	MHR512	G C S	MHL112	MHR112	G C S
	916	S, SP	916	94-97	MHL512	MHR512	G C S	MHL112	MHR112	G C S
ST4	916		S2	04-06	MHL513	MHR513	G C S	MHL113	MHR113	G C S
ST2	944		S1	97-03	MHL512	MHR512	G C S	MHL112	MHR112	G C S
ST3	992		S3	03-07	MHL513	MHR513	G C S	MHL113	MHR113	G C S
S4R	996	Monster	M4	03-06	MHL513	MHR513	G C S	MHL113	MHR113	G C S
S4R	996	Monster	M4	07-	MHLR525	MHR523	G C S	MHLR125	MHR123	G C S
	996	, S, R	H2	99-03	MHL513	MHR513	G C S	MHL113	MHR113	G C S
ST4 S	996		S2	01-03	MHL513	MHR513	G C S	MHL113	MHR113	G C S
ST4 S	996		S3	03-06	MHL513	MHR513	G C S	MHL113	MHR113	G C S
	998	S, Biposto	H2	01-04	MHL513	MHR513	G C S	MHL113	MHR113	G C S
	999	, S, R	H4	02-08	MHLR525	MHR523	G C S	MHLR125	MHR123	G C S
M	1000	Monster i. E.	M4	03-08	MHL513	MHR513	G C S	MHL113	MHR113	G C S
	1000	Multistrada DS, S	A1	04-06	MHL513	MHR513	G C S	MHL113	MHR113	G C S
	1000	GT	C1	05-10	MHL513	MHR513	G C S	MHL113	MHR113	G C S
	1000	Paul Smart Replica	C1	05-08	MHL513	MHR513	G C S	MHL113	MHR113	G C S
	1000	Sport	C1	05-08	MHL513	MHR513	G C S	MHL113	MHR113	G C S
	1000	SS i. E.	V5	02-07	MHL513	MHR513	G C S	MHL113	MHR113	G C S
	1098	, R, S	H7	07-08	MHLR525	MHR523	G C S	MHLR125	MHR123	G C S
	1098	Streetfighter, S		09-11	MHLR525	MHR523	G C S	MHLR125	MHR123	G C S
	1100	DS Multistrada	A1	06-09	MHL513	MHR513	G C S	MHL113	MHR113	G C S
	1100	Monster S		09-10	MHLR525	MHR523	G C S	MHLR125	MHR123	G C S
	1100	Monster EVO		11-13	MHLR525	MHR523	G C S	MHLR125	MHR123	G C S
	1198	S, R		09-11	MHLR525	MHR523	G C S	MHLR125	MHR123	G C S
	1200	Diavel		10-	MHLR525	MHR523	G C S	MHLR125	MHR123	G C S
	1200	Multistrada		10-	MHLR525	MHR523	G C S	MHLR125	MHR123	G C S
Honda										
CB	600	Hornet	PC34	98-01	MHL514	MHR514	G C S	MHL114	MHR114	G C S
CB	600	Hornet	PC36	02-06	MHL514	MHR514	G C S	MHL114	MHR114	G C S
CBF	600		PC38	04-07	MHL514	MHR514	G C S	MHL114	MHR114	G C S
CBR	600	F	PC19	87-88	MHL514	MHR514	G C S	MHL114	MHR114	G C S
CBR	600	F	PC23	89-90	MHL514	MHR514	G C S	MHL114	MHR114	G C S
CBR	600	F	PC25	91-93	MHL514	MHR514	G C S	MHL114	MHR114	G C S
CBR	600	F	PC31	95-97	MHL514	MHR514	G C S	MHL114	MHR114	G C S
CBR	600	F	PC35	98-00	MHL514	MHR514	G C S	MHL114	MHR114	G C S
CBR	600	F	PC35	01-08	MHL514	MHR514	G C S	MHL114	MHR114	G C S
CBR	600	RR	PC37	03-06	MHL515	MHR515	G C S	MHL115	MHR115	G C S
CBR	600	RR	PC40	07-13	MHL515	MHR516	G C S	MHL115	MHR116	G C S
NT	650	Deauville	RC47	02-05	MHL514	MHR514	G C S	MHL114	MHR114	G C S
NT	700	Deauville	RC52	06-07	MHL514	MHR514	G C S	MHL114	MHR114	G C S
VFR	750	F	RC36	89-97	MHLR530	MHR514	G C S			
VFR	800	FIW	RC46	02-10	MHL516	MHR514	G C S	MHL116	MHR114	G C S
VFR	800	Cross Runner		12-13	MHL516	MHR514	G C S	MHL116	MHR114	G C S
CB	900	Hornet	SC48	01-07	MHL514	MHR514	G C S	MHL114	MHR114	G C S
CBR	900	RR	SC33	96-99	MHL514	MHR514	G C S	MHL114	MHR114	G C S
CBR	900	RR	SC44	00-01	MHL514	MHR515	G C S	MHL114	MHR115	G C S
CBR	954	RR	SC50	02-06	MHL515	MHR515	G C S	MHL115	MHR115	G C S
CBR	1000	RR	SC57	04-07	MHL516	MHR516	G C S	MHL116	MHR116	G C S
CBR	1000	RR	SC59	08-13	MHL515	MHR516	G C S	MHL115	MHR116	G C S
CBF	1000		SC58	06-09	MHLR530	MHR514	G C S			
CB	1000	R	SC60	08-13	MHL516	MHR531	S			
VTR	1000	F	SC36	97-05	MHLR530	MHR514	G C S			
VTR	1000	SP-1	SC45	00-02	MHL516	MHR515	G C S			
VTR	1000	SP-2	SC45	02-06	MHL516	MHR515	G C S			

							Farbe Colour Couleur			Farbe Colour Couleur
VFR	1200	Cross Tourer		12-	MHL516	MHR514	G C S			
CB	1300	F, S	SC54	03-13	MHL516	MHR514	G C S	MHL116	MHR114	G C S
Kawasaki										
ER-5	500		ER500D	04-05	MHL535	MHR517	G C S	MHL135	MHR117	G C S
GPZ	500			90-95	MHL535	MHR517	G C S	MHL135	MHR117	G C S
KLE	500			91-97	MHL535	MHR517	G C S	MHL135	MHR117	G C S
ER-6	600	F, N		06-08	MHL535	MHR517	G C S	MHL135	MHR117	G C S
ZZR	600		ZX600E	93-02	MHL535	MHR517	G C S	MHL135	MHR117	G C S
ZX-6R	600	Ninja	ZX600G/J	97-99	MHL535	MHR517	G C S	MHL135	MHR117	G C S
ZX-6R	600	Ninja	ZX600J	00-02	MHL517	MHR517	G C S	MHL117	MHR117	G C S
ZX-6RR	600	Ninja	ZX600K	03-06	MHL517	MHR517	G C S	MHL117	MHR117	G C S
ZX-6R	600	Ninja	ZX600P	07-13	MHL517	MHR521	G C S	MHL117	MHR121	G C S
ZX-6R	636	Ninja	ZX636A	02-04	MHL517	MHRR518	G C S	MHL117	MHR117	G C S
ZX-6R	636	Ninja	ZX636B	03-04	MHL517	MHRR518	G C S	MHL117	MHR117	G C S
ZX-6R	636	Ninja	ZX636C	05-06	MHL517	MHRR518	G C S	MHL117	MHR118	G C S
KLE	650	Versys	LE650A	06-13	MHL535	MHR517	G C S	MHL135	MHR117	G C S
Z	750		ZR750J	03-06	MHL535	MHR517	G C S	MHL135	MHR117	G C S
Z	750		ZR750L	07-13	MHL517	MHR511	G C S			
Z	750	R		11-12	MHL517	MHR521	G C S	MHL117	MHR121	G C S
ZR	750	Zephyr		91-97	MHL535	MHR517	G C S	MHL135	MHR117	G C S
ZR-7	750		ZR750F	99-04	MHL535	MHR517	G C S	MHL117	MHR117	G C S
Z	800			13-14	MHL517	MHR511	G C S			
ZX-9R	900		ZX900C	98-99	MHL535	MHR517	G C S	MHL135	MHR117	G C S
ZX-9R	900		ZX900E	00-03	MHL517	MHR517	G C S	MHL117	MHR117	G C S
Z	1000		ZRT00A	03-06	MHL517	MHR517	G C S	MHL117	MHR117	G C S
Z	1000		ZRT00B	07-12	MHL517	MHR521	G C S	MHL117	MHR121	G C S
Z	1000	SX		11-13	MHL517	MHR521	G C S	MHL117	MHR121	G C S
ZX-10R	1000	Ninja	ZXT00C	04-05	MHL517	MHR517	G C S	MHL117	MHR117	G C S
ZX-10R	1000	Ninja	ZXT00D	05-07	MHL517	MHR521	G C S	MHL117	MHR121	G C S
ZX-10R	1000	Ninja	ZXT00E	08-14	MHL517	MHR521	G C S	MHL117	MHR121	G C S
ZR	1100	Zephyr		91-97	MHL535	MHR517	G C S			
ZRX	1100		ZRT10C	96-00	MHL534	MHR517	G C S	MHL134	MHR117	G C S
ZZR	1100		ZXT10D	93-01	MHL535	MHR517	G C S	MHL135	MHR117	G C S
ZRX	1200	R, S	ZRT20A	00-07	MHL534	MHR517	G C S	MHL134	MHR117	G C S
ZX-12R	1200	Ninja	ZXT20A/B	00-06	MHL517	MHR517	G C S	MHL117	MHR117	G C S
ZZR	1200		ZXT20C	02-05	MHL534	MHR517	G C S	MHL134	MHR117	G C S
ZZR	1400		ZXT40A	06-13	MHL523	MHR521	G C S	MHL123	MHR121	G C S
VN	1500	Classic + Tourer		98-03	MHL534	MHR517	G C S	MHL134	MHR117	G C S
VN	1500	Mean Streak		02-03	MHL534	MHR517	G C S	MHL134	MHR117	G C S
VN	1600	Mean Streak		04-06	MHL534	MHR517	G C S	MHL134	MHR117	G C S
VN	1600	Classic + Tourer		03-05	MHL534	MHR517	G C S	MHL134	MHR117	G C S
KTM										
SM-R	690	Duke		08-	MHL538	MHRR523	G S	MHL138	MHRR123	G S
LC-8	990	Super Duke	KTMLC8EFI	04-08	MHL538	MHRR523	G S	MHL138	MHRR123	G S
RC-8	1190			08-13	MHL538	MHRR523	G S	MHL138	MHRR123	G S
Moto Guzzi										
	940	Bellagio		07-10	MHL513	MHR522	G C S	MHL113	MHR122	G C S
	1100	Breva	LP	05-07	MHL513	MHR522	G C S	MHL113	MHR122	G C S
	1100	/1200 Griso	LS	06-09	MHL513	MHR522	G C S	MHL113	MHR122	G C S
	1200	Breva		10-11	MHL513	MHR522	G C S	MHL113	MHR122	G C S
	1200	Norge	LS	06-13	MHL513	MHR522	G C S	MHL113	MHR122	G C S
	1200	Sport	LP	06-09	MHL513	MHR522	G C S	MHL113	MHR122	G C S
	1200	Sport 8V		09-13	MHL513	MHR522	G C S	MHL113	MHR122	G C S
	1200	Stelvio		08-13	MHL513	MHR522	G C S	MHL113	MHR122	G C S

							Farbe Colour Couleur			Farbe Colour Couleur
Moto Morini										
	1000	9,5		08-09	MHL513	MHR522	G C S	MHL113	MHR122	G C S
	1200	Granpasso		08-09	MHLR525	MHRR523	G C S	MHLR125	MHRR123	G C S
	1200	Corsaro		08-09	MHL513	MHR522	G C S	MHL113	MHR122	G C S
	1200	Scrambler		09-	MHL513	MHR522	G C S	MHL113	MHR122	G C S
	1200	Veloce		08-09	MHL513	MHR522	G C S	MHL113	MHR124	G C S
Suzuki										
GSR	600		WVB9	06-08	MHL518	MHR517	G C S	MHL118	MHR117	G C S
GSX-R	600		AD	96-00	MHL518	MHR517	G C S	MHL118	MHR117	G C S
GSX-R	600		WVBG	00-03	MHL518	MHR517	G C S	MHL118	MHR117	G C S
GSX-R	600		WVB2	04-05	MHL518	MHR518	G C S	MHL118	MHR118	G C S
GSX-R	600		WVCE	06-07	MHL519	MHRR518	B G C S	MHL119	MHRR118	B G C S
GSX-R	600		WVCV	08-12	MHL519	MHRR518	B G C S	MHL119	MHRR118	B G C S
GSF	650	Bandit	WVCJ	07-12	MHL522	MHR517	G C S	MHL122	MHR117	G C S
GSX	650	F		09-12	MHL522	MHR517	G C S	MHL122	MHR117	G C S
SV	650	Gladius		09-13	MHL518	MHR517	G C S	MHL118	MHR117	G C S
SV	650	, S	WVBY	03-08	MHLR539	MHR517	G C S			
SV	650	, S	WVBY	09-12	MHL518	MHR517	G C S	MHL118	MHR117	G C S
DL	650	V-Strom	WVB1	04-11	MHLR539	MHR517	G C S			
DL	650	V-Strom		12-13	MHL518	MHR517	G C S	MHL118	MHR117	G C S
GSR	750			11-13	MHL518	MHR517	G C S	MHL118	MHR117	G C S
GSX-R	750		GR7DB	96-99	MHL518	MHR517	G C S	MHL118	MHR117	G C S
GSX-R	750		WVBD	00-03	MHL518	MHR517	G C S	MHL118	MHR117	G C S
GSX-R	750		WFB3	04-05	MHL518	MHR518	G C S	MHL118	MHR118	G C S
GSX-R	750		WVCF	06-07	MHL519	MHRR518	B G C S	MHL119	MHRR118	B G C S
GSX-R	750		WVCW	08-12	MHL519	MHRR518	B G C S	MHL119	MHRR118	B G C S
DL	1000	V-Strom	WVBS	02-08	MHL522	MHR517	G C S	MHL122	MHR117	G C S
GSX-R	1000		WVBL	01-02	MHL518	MHR517	G C S	MHL118	MHR117	G C S
GSX-R	1000		WVBZ	03-04	MHL518	MHR517	G C S	MHL118	MHR117	G C S
GSX-R	1000		WVB6	05-06	MHL519	MHRR518	G C S	MHL119	MHRR118	G C S
GSX-R	1000		WVCL	07-08	MHLR522	MHRR518	B G C S	MHLR122	MHRR118	B G C S
GSX-R	1000		WVCY	09-13	MHL554	MHRR518	B G C S	MHL154	MHRR118	B G C S
SV	1000	, S	WVBX	03-08	MHL522	MHR517	G C S	MHL122	MHR117	G C S
GSF	1200	, S Bandit	WVA9	00-05	MHL522	MHR517	G C S	MHL122	MHR117	G C S
GSF	1200	, S Bandit	WVCB	06	MHL522	MHR517	G C S	MHL122	MHR117	G C S
GSF	1250	, S Bandit	WVCH	07-12	MHL522	MHR517	G C S	MHL122	MHR117	G C S
GSX-R	1300	Hayabusa	WVA1	98-07	MHL522	MHR517	G C S	MHL122	MHR117	G C S
GSX-R	1300	Hayabusa	WVCK	08-13	MHL522	MHR517	G C S	MHL122	MHR117	G C S
GSX	1400		WVBN	01-08	MHL522	MHR517	G C S	MHL122	MHR117	G C S
Triumph										
TT	600		806AD	00-03	MHL527	MHR517	G C S			
	600	Speed Four	H811	03-04	MHL527	MHR517	G C S			
	600	Speed Four	H811	05-06	MHL526	MHR517	G C S	MHL126	MHR117	G C S
	600	Daytona	806LW	03-05	MHL526	MHR517	G C S	MHL126	MHR117	G C S
	650	Daytona	865LX	05	MHL526	MHR517	G C S	MHL126	MHR117	G C S
	675	Daytona	D67LC	06-13	MHL526	MHRR518	G C S	MHL126	MHRR118	G C S
	675	R		11-13	MHL526	MHRR523	G C S	MHL126	MHRR123	G C S
	675	Street Triple	D67LD	07-13	MHL526	MHR517	G C S	MHL126	MHR117	G C S
	675	Street Triple R		09-13	MHL526	MHRR518	G C S	MHL126	MHRR118	G C S
	800	Scrambler		06-13	MHL526	MHR517	G C S	MHL126	MHR117	G C S
	800	Speedmaster	908ML	01-05	MHL526	MHR517	G C S	MHL126	MHR117	G C S
	865	Speedmaster	986ML	05-12	MHL526	MHR517	G C S	MHL126	MHR117	G C S
	900	Bonneville	986MK	06-13	MHL526	MHR517	G C S	MHL126	MHR117	G C S
	900	Thrupton	986ME	04-13	MHL526	MHR517	G C S	MHL126	MHR117	G C S

							Farbe Colour Couleur			Farbe Colour Couleur
955	Daytona	T595	97-00	MHL527	MHR517	G C S				
955	Daytona	595N	01-03	MHL527	MHR517	G C S				
955	Daytona i	595N	04-05	MHL526	MHR517	G C S	MHL126	MHR117	G C S	
955	Sprint RS	T695	99-01	MHL526	MHR517	G C S	MHL126	MHR117	G C S	
955	Sprint RS	695AC	02-04	MHL526	MHR517	G C S	MHL126	MHR117	G C S	
955	Sprint ST	T695	98-04	MHL527	MHR517	G C S				
955	Tiger		01-06	MHL527	MHR517	G C S				
1050	Speed Tr. Axialbremse	515NJ	04-07	MHL526	MHR517	G C S	MHL126	MHR117	G C S	
1050	Speed Tr. Radialbremse	515NJ	08-10	MHL526	MHRR518	G C S	MHL126	MHR118	G C S	
1050	Speed Tr. Radialbremse		11-13	MHL526	MHRR523	G C S	MHL126	MHRR123	G C S	
1050	Sprint ST/ABS	215NA	04-11	MHL526	MHR517	G C S	MHL126	MHR117	G C S	
1050	GT/ABS		10-13	MHL526	MHR517	G C S	MHL126	MHR117	G C S	
1050	Tiger	T709	07-13	MHL526	MHR517	G C S	MHL126	MHR117	G C S	
2300	Rocket	C23XBS3	03-08	MHL526	MHR517	G C S	MHL126	MHR117	G C S	
Yamaha										
FZS	600 Fazer	RJ02	97-03	MHL529	MHR517	G C S	MHL129	MHR117	G C S	
FZ-6	600 Fazer	RJ07	04-05	MHL520	MHR522	G C S	MHL120	MHR122	G C S	
FZ-6	600 Fazer	RJ14	06-10	MHL520	MHR522	G C S	MHL120	MHR122	G C S	
XJ6	600 Diversion	RJ19	09-13	MHL521	MHR522	G C S	MHL120	MHR122	G C S	
YZF	600 R6	RJ03	98-02	MHL520	MHR517	G C S	MHL120	MHR117	G C S	
YZF	600 R6	RJ05	03	MHL520	MHR517	G C S	MHL120	MHR117	G C S	
YZF	600 R6	RJ09	04-05	MHL520	MHR517	G C S	MHL120	MHRR119	G C S	
YZF	600 R6	RJ11	05-07	MHL520	MHRR519	G C S	MHL120	MHRR119	G C S	
YZF	600 R6	RJ15	08-13	MHL520	MHRR519	G C S	MHL120	MHRR119	G C S	
FZ-8	800 , Fazer /ABS	RN25	10-13	MHL520	MHR522	G C S	MHL120	MHR122	G C S	
FZS	1000 Fazer	RN06	00-03	MHL521	MHR517	G C S	MHL121	MHR117	G C S	
FZS	1000 Fazer	RN14	04-05	MHL521	MHR517	G C S	MHL121	MHR117	G C S	
FZ-1	1000 Fazer	RN16	06-13	MHL521	MHR522	G C S	MHL121	MHR122	G C S	
YZF	1000 R1	RN04	00-01	MHL521	MHR520	G C S	MHL121	MHR120	G C S	
YZF	1000 R1	RN09	02-03	MHL521	MHR520	G C S	MHL121	MHR120	G C S	
YZF	1000 R1	RN12	04-06	MHL521	MHRR519	G C S	MHL121	MHRR119	G C S	
YZF	1000 R1	RN19	07-08	MHL521	MHRR519	G C S	MHL121	MHRR119	G C S	
YZF	1000 R1	RN22	09-13	MHL520	MHRR547	G C S	MHL120	MHRR147	G C S	
VMX	1200 V-Max all modells		85-	MHL551	MHR545	S	MHL151	MHR145	S	
XJR	1200	4PU	95-99	MHL524	MHR517	G C S	MHL124	MHR117	G C S	
XTZ	1200 Super Tenere ABS	DP01	10-13	MHL524	MHR522	G C S	MHL124	MHR122	G C S	
FJR	1300	RP04	00-02	MHL524	MHR517	G C S	MHL124	MHR117	G C S	
FJR	1300	RP08	03	MHL524	MHR522	G C S	MHL124	MHR122	G C S	
FJR	1300 ABS	RP11	03-05	MHL524	MHR522	G C S	MHL124	MHR122	G C S	
FJR	1300 A/AS ABS	RP13	06-13	MHL524	MHR522	G C S	MHL124	MHR122	G C S	
XJR	1300	RP02	98-01	MHL524	MHR517	G C S	MHL124	MHR117	G C S	
XJR	1300	RP06	02-03	MHL524	MHR517	G C S	MHL124	MHR117	G C S	
XJR	1300	RP10	04-05	MHL524	MHR517	G C S	MHL124	MHR117	G C S	
XJR	1300	RP19	06-	MHL524	MHR522	G C S	MHL124	MHR122	G C S	
MT-01	1700	RP12	04-06	MHL524	MHRR519	G C S	MHL124	MHRR119	G C S	
MT-01	1700	RP18	06-13	MHL524	MHRR519	G C S	MHL124	MHRR119	G C S	

ACHTUNG! CAUTION! ATTENTION!

Bitte gewünschte Farbe ergänzen.

Please indicate required colour.

Veillez indiquer la couleur souhaitée.

	C: silber	silver argent
	G: gold	gold or
	S: schwarz	black noir
	B: blau	blue bleu



HECKHÖHER-/TIEFERLEGUNGEN

*KITS DE SURBAISSEMENT / DE SURÉLÉVATION
LOWERING / JACK UP KITS*

HECKTIEFERLEGUNGEN

KITS DE SURBAISSEMENT LOWERING KITS

» mit ABE, keine Eintragung nötig

- » ermöglicht sicheren Stand durch mehr Bodenkontakt
- » wie die Höherlegungen sind auch die Tieferlegungen aus Stahl oder Aluminium gefräst
- » durch die Absenkung muss bei den meisten Modellen der Seitenständer gekürzt werden
- » Zugstreben zur Tieferlegung sind länger als das Originalteil
- » die Tieferlegung sollte ausschließlich durch eine Fachwerkstatt durchgeführt werden

» with TÜV approval

- » allows more secure stand through greater ground contact
- » as with the jack up kits, the lowering kits are also in stainless steel or milled aluminium
- » for most models lowering means that the side stands must be shortened
- » tie rods for lowering are longer than the original part
- » the lowering should only be carried out by a specialist workshop

» avec homologation TÜV

- » permet un soutien plus sûr grâce à un meilleur contact avec le sol
- » comme les kits de surélévation, les kits de surbaissement sont fraisés dans de l'acier ou de l'aluminium
- » sur la plupart des modèles, les béquilles latérales doivent être raccourcies pour le surbaissement
- » les tirants pour kits de surbaissement sont plus longs qu les pièces d'origine
- » les kits de surbaissement ne peuvent être montés que par des ateliers spécialisés



← Vorher
before
avant

Nachher →
after
après



HECKHÖHERLEGUNGEN

JACK UP KITS KITS DE SURELEVATION

» mit ABE, keine Eintragung nötig

- » passgenaue Höherlegung des Hecks
- » besseres Handling durch geänderte Fahrwerksgeometrie
- » ermöglicht zwischen 25 mm bis 45 mm mehr Bodenfreiheit
- » mehr Last auf dem Vorderrad und bessere Optik
- » inkl. aussagefähiger Montageanleitung
- » die Höherlegung sollte ausschließlich durch eine Fachwerkstatt durchgeführt werden

» with TÜV approval

- » precise raising of the rear end
- » better handling through modified suspension geometry
- » allows between 25 to 45 mm more ground clearance
- » more load on the front wheel and improved appearance
- » including detailed assembly instructions
- » the raising should only be carried out by a specialist workshop

» avec homologation TÜV

- » surélévation correcte de l'arrière
- » meilleure manipulation grâce à une géométrie d'outil modifiée
- » permet une garde au sol de 25 à 45 mm
- » plus de poids sur la roue avant et design amélioré
- » comprenant des indications de montage explicites
- » les kits de surélévation ne peuvent être montés que par des ateliers spécialisés

TYPENÜBERSICHT

VUE D'ENSEMBLE DES TYPES

TYPES SUMERY



TYP 01



TYP 02



TYP 03



TYP 04



TYP 05

Mit Verlängerung für den Seitenständer
With stand extensions
Avec rallonge pour béquilles latérales



TYP 06

Mit abgedichteten Nadelhülsen, die über eine hohe Tragfähigkeit verfügen
With high load capacity sealed needle roller bearings
Avec douilles d'aiguille étanches, présentant une résistance accrue



TYP 07



TYP 08

Typ 01 + Typ 03 sind aus hochwertigem Stahl, lasergeschnitten; alle anderen Typen aus Aluminium, CNC-gefräst.

Type 01 + type 03 made in stainless steel, laser cut; all other models in aluminium, CNC-milled.



TYP 09



TYP 10

Type 01 et type 03 fabriqués en acier inoxydable par découpe laser; les autres modèles sont fabriqués en aluminium fraisé par CNC.



Messung der Höhenänderung lotrecht über der Hinterachse

Measuring the change in perpendicular height above the rear axle

Mesure de la modification de la hauteur verticalement au-dessus de l'essieu arrière









ACHTUNG! CAUTION! ATTENTION!









Nach der Umbaumaßnahme ist es erforderlich, dass, je nach Beladung des Fahrzeugs, das Federstoßdämpfer-Management entsprechend angepasst wird, da es sonst zu Schäden am Fahrzeug bzw. an Fahrzeugteilen kommen kann.









Following conversion and depending on the bike load, the spring shock absorber system must be modified accordingly, otherwise damage to bike or bike components may occur.









Selon les dimensions, il est nécessaire d'adapter la gestion des amortisseurs à ressort en fonction du chargement du véhicule. Sans cela, le véhicule ou des pièces de celui-ci pourraient être endommagées.

							Typ				Typ	
					+ mm				- mm			
Aprilia												
SL	750	Shiver	RA	07-10	---	---	---		MCTL161	35	10	3) 6)
SMV	750	Dorsoduro	SM	07-	---	---	---		MCTL161	25	10	3) 6)
NA	850	Mana	RC	07-10	---	---	---		MCTL162	35	10	3) 6)
RSV	1000	Mille	ME	99-	MCHL103	25	01		MCTL123	30	01	
RSV	1000	Mille	RP	00-	MCHL156	30	01		MCTL143	30	01	
RSV	1000	Mille	RR	03-	MCHL156	30	01		MCTL143	30	01	
RSV	1000	Tuono	RP	02-	MCHL156	30	01		MCTL143	30	01	
RSV	1000	R Tuono	RR	06-10	MCHL156	30	01		MCTL143	30	01	
RSV	1000	R Factory	RR	06-10	MCHL156	30	01		MCTL143	30	01	
RSV4	1000		RK	09-	MCHL156	30	01		MCTL143	20	01	
BMW												
G	450	X		08-	---	---	---		MCTL156	18	10	3)
F	650	CS Scarver	K14	02-05	---	---	---		MCTL144	25	03	
F	650	CS Scarver	E650C	03-06	---	---	---		MCTL144	25	03	
F	650		651EA	01-03	---	---	---		MCTL127	25	09	
F	650		E650G	04-07	---	---	---		MCTL127	25	09	
F	650	GS	R13	01-03	---	---	---		MCTL127	25	09	
F	650	GS	E650G	04-07	---	---	---		MCTL127	25	09	
G	650	GS	E650G	09-	---	---	---		MCTL127	25	09	
G	650	Xmoto	E65X	07-	---	---	---		MCTL161	40	10	3)
G	650	Xcountry	E65X	07-	---	---	---		MCTL161	40	10	3)
R	850	GS	BMW 259	93-	MCHL158	25	08		---	---	---	
R	850	GS	R21	01-	MCHL158	25	08		---	---	---	
R	1100	GS	BMW 259	93-	MCHL158	25	08		---	---	---	
R	1150	GS	R21	99-	MCHL158	25	08		---	---	---	
R	1150	GS Advent.	R21	01-	MCHL158	25	08		---	---	---	
K	1200	S	K12S	05-09	MCHL167	25	01		MCTL173	25	01	
K	1200	R	K12	05-09	MCHL167	25	01		MCTL173	25	01	
K	1200	R	K12R	07-08	MCHL167	25	01		MCTL173	25	01	
K	1300	S, R, GT	K12S	09-	MCHL167	25	01		MCTL173	25	01	
K	1600	GT	K16GT	12-	---	---	---		MCTL155	30	01	
Cagiva												
	650	Raptor	M2	02-	MCHL166	25	01		MCTL167	25	01	
	1000	Raptor	M2	02-	---	---	---		MCTL167	25	01	
Ducati												
	696	Monster	M5	08-	---	---	---		MCTL161	30	10	3) 6)
	796	Monster	M5	11-	---	---	---		MCTL161	30	10	3) 6)
	1100	Monster	M5	08-	---	---	---		MCTL161	30	10	3) 6)
	1100	Monster EVO	M5	11-	---	---	---		MCTL161	30	10	3) 6)
Honda												
XL	125	Varadero	JC32	01-	---	---	---		MCTL132	30	02	3)

							Typ				Typ	
						+ mm				- mm		
XR	125	L	JD19	03-	---	---	---		MCTL132	30	02	3)
CBF	500		PC39	04-	MCHL116	30	02	4)	MCTL118	30	02	4)
CBR	500	R	PC44	13-	MCHL174	25	01		MCTL183	30	01	
CB	500	F/X		13-	MCHL174	25	01		MCTL183	30	01	
CB	600	Hornet	PC34	98-99	MCHL111	35	07	4)	MCTL101	35	07	4)
CB	600	Hornet	PC34	00-01	MCHL111	35	07	4)	MCTL101	35	07	4)
CB	600	Hornet	PC36	02-06	MCHL111	35	07	4)	MCTL101	35	07	4)
CB	600	Hornet	PC41	07-08	MCHL116	30	02	4)	MCTL118	35	02	4)
CBF	600	N, S	PC38	04-	MCHL116	30	02	4)	MCTL118	35	02	4)
CBF	600	N, S	PC43	08-	MCHL116	30	02	4)	MCTL118	35	02	4)
CBR	600	F	PC25	91-	---	---	---		MCTL133	35	06	
CBR	600	F	PC31	95-98	MCHL118	30	06	5)	MCTL133	35	06	5)
CBR	600		PC35	99-00	MCHL117	30	03		MCTL100	35	03	
CBR	600		PC35	01-	MCHL117	30	03		MCTL100	35	03	
CBR	600	RR	PC40	07-	MCHL161	25	01		MCTL145	25	01	
CBR	600	RA	PC40	09-	MCHL161	25	01		MCTL145	25	01	
NTV	650	Deauville	RC47	98-05	---	---	---		MCTL118	25	02	3)
NC	700	S,SA,SD	RC61	12-	MCHL168	35	03		MCTL176	30	03	
NC	700	D	RC62	12-	MCHL168	35	03		MCTL176	30	03	
NC	700	X	RC63	12-	MCHL168	35	03		MCTL176	30	03	
NT	700	Deauville	RC52	06-	---	---	---		MCTL118	25	02	3)
NT	700	Deauville	RC59	10-	---	---	---		MCTL118	25	02	3)
NC	750	SA,SD,S	RC70	14-	MCHL168	35	03		MCTL176	30	03	
NC	750	X,XA,XD	RC72	14-	MCHL168	35	03		MCTL176	30	03	
VFR	800	ABS	RC46	02-	MCHL113	25	01		MCTL134	25	01	
VFR	800	X Crossrunner	RC60A	11-	MCHL113	25	01		MCTL134	25	01	
CBR	900	RR	SC28	92-95	MCHL100	25	01		---	---	---	
CBR	900	RR	SC33	96-99	MCHL101	35	01		---	---	---	
CBR	900	RR	SC44	00-	MCHL102	25	01		MCTL116	25	01	
CBR	900	RR	SC50	02-	MCHL103	25	01		MCTL123	25	01	
CBF	1000		SC58	06-	MCHL116	30	02	4)	---	---	---	
CBR	1000	RR, RA	SC57	04-07	MCHL115	30	06		MCTL181	35	06	
CBR	1000	RR	SC59	08-	MCHL162	30	01		MCTL147	40	01	
CBR	1000	RA	SC59	09-	MCHL162	30	01		MCTL147	40	01	
VTR	1000	F	SC36	97-	MCHL155	30	07	3)	---	---	---	
VTR	1000	F	SC36	04-	MCHL155	30	07	3)	---	---	---	
VTR	1000	SP 1	SC45	00-	MCHL157	30	07	3)	---	---	---	
VTR	1000	SP 2	SC45	02-	MCHL157	30	07	3)	---	---	---	
XL	1000	Varadero	SD01	99-03	MCHL114	30	01		MCTL135	35	01	
XL	1000	Varadero	SD02	01-	MCHL114	30	01		MCTL102	35	01	
XL	1000	Varadero	SD03	11-	MCHL114	30	01		MCTL102	35	01	
CB	1100	X-eleven	SC42	99-	MCHL116	25	02	4)	MCTL118	35	02	4)
CBR	1100	XX	SC35	01-	MCHL116	30	02	4)	MCTL117	30	01	
VFR	1200	F	SC63	10-	MCHL165	30	01		MCTL172	25	01	
VFR	1200	X	SC70	12-	MCHL171	35	01		MCTL179	30	01	
Husquvarna												
	650	Terra/Strada	A8	12-	---	---	---		MCTL156	35	10	3) 6)
	900	Nuda	HA700A	12-	---	---	---		MCTL161	35	10	3) 6)
	900	Nuda R	OH02	12-	---	---	---		MCTL162	35	10	3) 6)
Kawasaki												
ZX	250	R	EX250K	08-	MCHL105	30	03		MCTL139	25	03	
	300	Ninja	EX300A	12-	MCHL105	30	03	8)	MCTL184	25	03	8)
Z	300		ER300A	15-	MCHL143	30	03		MCTL184	25	03	
GPZ	500	S	EX500D (E)	94-	---	---	---		MCTL112	40	03	
ZX-6R	600	Ninja	ZX600F	95-	MCHL110	30	03		MCTL103	35	03	
ZX-6R	600	Ninja	ZX600G	98-99	MCHL110	30	03		MCTL124	35	03	
ZX-6R	600	Ninja	ZX600J	00-02	MCHL110	30	03		MCTL124	35	03	
ZX-6RR	600	Ninja	ZX600K	03-04	---	---	---		MCTL124	35	03	
ZX-6RR	600	Ninja	ZX600N	05-06	MCHL110	30	03		MCTL103	35	03	
ZX-6R	600	Ninja, RR	ZX600P	06-08	MCHL110	30	03		MCTL103	40	03	
ZX-6R	600	Ninja, R	ZX600R	09-12	---	---	---		MCTL119	40	03	
ZX-6R	636	Ninja	ZX636A	02-	MCHL110	30	03		MCTL124	35	03	
ZX-6R	636	Ninja	ZX636B	03-04	MCHL110	30	03		MCTL124	35	03	
ZX-6R	636	Ninja	ZX636C	04-06	MCHL110	30	03		MCTL103	35	03	
ZX-6R	636	Ninja	ZX636E	13-	MCHL110	30	03		MCTL103	35	03	
ER-6	650	N	ER650A	06-08	---	---	---		MCTL125	25	10	3) 6)
ER-6	650	F	EX650A	06-08	---	---	---		MCTL125	25	10	3) 6)
	650	Versys	LE650A (A,B)	06-	---	---	---		MCTL163	25	04	
	650	Versys	LE650C (C,D)	10-	---	---	---		MCTL163	25	04	
	650	Versys	LE650E	15-	---	---	---		MCTL163	25	04	
Z	750	/S	ZR750J	04-06	MCHL110	30	03		MCTL103	30	03	
Z	750	/S	ZR750L	07-12	MCHL123	30	03		MCTL106	30	03	
ZX-7R	750	Ninja	ZX750N (N,P)	96-	MCHL110	30	03		---	---	---	
Z	750	R	ZR750N	11-	MCHL123	30	03		MCTL106	30	03	
Z	750	R	ZR750P	11-	MCHL123	30	03		MCTL106	30	03	
Z	800		ZR800A/C	12-	MCHL120	35	03		MCTL103	35	03	

							Typ				Typ	
ZX-9 R	900	Ninja	ZX900C (C,D)	98-00	MCHL110	30	03		MCTL124	35	03	
ZX-9 R	900	Ninja	ZX900E (E,F)	01-03	MCHL110	30	03		MCTL124	35	03	
KLV	1000		VVBS	02-	MCHL144	30	03		MCTL111	25	03	
KLV	1000	Versys	LZT00A	11-	MCHL164	35	01		MCTL166	20	01	
Z	1000		ZRT00A	03-06	MCHL110	25	03		MCTL103	30	03	
Z	1000		ZRT00B (B,C)	07-	MCHL120	30	03		MCTL106	30	03	
Z	1000		ZRT00D (D,E)	10-	MCHL164	30	01		MCTL166	30	01	
Z	1000		ZRT00F	14-	MCHL169	30	01		MCTL177	30	01	9)
Z	1000	SX	ZXT00G	11-	MCHL164	30	01		MCTL166	30	01	
Z	1000	SX	ZXT00L	14-	MCHL164	30	01		MCTL166	30	01	
ZX-10R	1000	Ninja	ZXT00C	04-05	MCHL110	30	03		MCTL124	30	03	
ZX-10R	1000	Ninja	ZXT00D	06-07	MCHL110	30	03		MCTL141	25	03	
ZX-10R	1000	Ninja	ZXT00E	08-	MCHL163	25	03		MCTL150	25	03	
ZX-10R	1000	Ninja	ZXT00F	10	MCHL163	25	03		MCTL150	25	03	
ZX-10R	1000	Ninja	ZXT00J	11-	MCHL163	25	03		MCTL150	25	03	
ZX-12R	1200	Ninja	ZXT20A	01-	MCHL110	30	03		MCTL119	30	03	
KTM												
	125	Duke		11-	MCHL172	30	02	3)	MCTL180	40	02	3)
RC	125	Duke		14-	MCHL172	20	02	3)	MCTL180	30	02	3)
	125	Duke ABS		13-	MCHL172	30	02	3)	MCTL180	40	02	3)
	200	Duke ABS		12-	MCHL172	30	02	3)	MCTL180	40	02	3)
	350	Freeride		12-	---	---	---	---	MCTL162	35	10	3)
	390	Duke		13-	MCHL172	30	02	3)	MCTL180	40	02	3)
RC	390	Duke		14-	---	---	---	---	MCTL180	30	02	3)
LC4	620		KTM-4T-EGS	98-	MCHL154	25	03		MCTL130	25	03	
	640	Duke II	KTM DK II	99-	---	---	---	---	MCTL130	25	03	
	690	SM, Enduro	690 LC4	08-	---	---	---	---	MCTL162	35	10	3) 6)
	690	SMC	690 LC4	08-	---	---	---	---	MCTL162	35	10	3) 6)
	690	SMC R	690 LC4	11-	---	---	---	---	MCTL162	35	10	3) 6)
	690	Duke	A3	08-11	---	---	---	---	MCTL162	20	10	3) 6)
	690	SM	A2	08-	---	---	---	---	MCTL162	20	10	3) 6)
	990	Super Duke, R	LC8 EFI	05-	---	---	---	---	MCTL162	25	10	3) 6)
	990	SMT, SMR	LC8 EFI	10-	---	---	---	---	MCTL162	35	10	3) 6)
	1050	Adventure	KV4340	15-	---	---	---	---	MCTL162	35	10	3) 6)
	1190	Adventure	KV2940	13-	---	---	---	---	MCTL162	35	10	3) 6)
Suzuki												
GS	500	E/EU	GM51B	89-00	MCHL110	25	03		MCTL109	40	03	1)
GS	500	E/EU	GM51A	89-00	MCHL110	25	03		MCTL109	40	03	1)
GS	500	E/EU	VVBK	01-	MCHL110	25	03		MCTL109	40	03	1)
GS	500	E/EU	BK	03-	MCHL110	25	03		MCTL109	40	03	1)
GSF	600	Bandit	GN77B	95-99	MCHL120	35	03		MCTL106	35	03	6)
GSF	600	Bandit, S	VVA8	00-04	MCHL120	35	03		MCTL106	30	03	
GSR	600		VVB9	06-	MCHL105	30	03		MCTL114	30	03	2)
GSX	600	F	AJ	98-	---	---	---	---	MCTL104	30	03	
GSX-R	600		AD	97-00	MCHL122	25	03		MCTL111	25	03	
GSX-R	600		VVBG	01-03	MCHL123	25	03		MCTL106	30	03	
GSX-R	600		VVB2	04-05	MCHL123	25	03		MCTL106	30	03	
GSX-R	600		VVCE	06-07	MCHL137	25	07	3)	MCTL122	25	07	3)
GSX-R	600		VVCV	08-	MCHL137	25	07	3)	MCTL122	25	07	3)
GSX-R	600		C3	11-	MCHL137	25	07	3)	MCTL122	25	07	3)
RF	600		GN76B	93-96	MCHL123	30	03		MCTL106	35	03	
SFV	650	Gladius	VVCX	09-	MCHL106	30	03		MCTL154	30	03	
DL	650	V-Strom	VVB1	04-06	MCHL144	30	03		MCTL111	30	03	
DL	650	V-Strom	VVB1	07-	MCHL144	30	03		MCTL111	30	03	
DL	650	V-Strom	C7	12-	MCHL141	30	03		MCTL111	30	03	
GSF	650	Bandit, S	VVB5	05-06	MCHL120	35	03		MCTL106	30	03	
GSF	650	Bandit, S	VVCJ	07-	MCHL120	35	03		MCTL106	30	03	
GSF	650	Bandit, S	VVCZ	09-	MCHL120	35	---	---	MCTL106	30	03	
GSX	650	F	VVCJ	08-	MCHL120	35	03		MCTL106	30	03	
SV	650		AV	99-02	MCHL124	30	03		MCTL107	30	03	
SV	650		VVBY	03-	MCHL144	25	03		MCTL108	30	03	
GSR	750		C5	11-	MCHL127	35	03		MCTL174	35	03	
GSX	750	F	AK	99-02	---	---	---	---	MCTL104	30	03	
GSX	750	F	VVAK	03-04	---	---	---	---	MCTL104	30	03	
GSX	750	F	VVAK	05-06	---	---	---	---	MCTL104	30	03	
GSX-R	750		GR77B	88-89	MCHL125	35	03		---	---	---	
GSX-R	750		GR77A	88-89	MCHL125	35	03		---	---	---	
GSX-R	750		GR7AB	90-91	MCHL125	35	03		---	---	---	
GSX-R	750		GR7BB	92-95	MCHL126	25	03		MCTL162	25	10	3) 6)
GSX-R	750		GR7BC	92-95	MCHL126	25	03		MCTL162	25	10	3) 6)
GSX-R	750		GR7DB	96-99	MCHL122	25	03		MCTL111	25	03	
GSX-R	750		VVBD	00-03	MCHL123	25	03		MCTL106	30	03	
GSX-R	750		VVB3	04-05	MCHL123	25	03		MCTL106	30	03	
GSX-R	750		VVCF	06-07	MCHL137	25	07	3)	MCTL122	25	07	3)
GSX-R	750		VVCW	08-10	MCHL137	25	07	3)	MCTL122	25	07	3)
GSX-R	750		C4	11-	MCHL137	25	07	3)	MCTL122	25	07	3)

						Typ				Typ	
GSX	750	AE	98-01	MCHL129	35	04		---	---	---	
RF	900	GT73B	94-97	MCHL140	30	03		MCTL106	30	03	
DL	1000	V-Strom	VVBS	02-13	MCHL144	30	03		MCTL111	20	03
DL	1000	V-Strom	DD	14-	MCHL173	30	01		MCTL155	30	01
GSX-S	1000	DG	15-	MCHL178	25	01		MCTL179	25	01	
GSX-R	1000	VVBL	01-02	MCHL123	25	03		MCTL106	30	03	
GSX-R	1000	VVBZ	03-04	MCHL123	25	03		MCTL106	30	03	
GSX-R	1000	VVB6	05-06	MCHL120	25	03		MCTL109	30	03	
GSX-R	1000	VVCL	07-08	MCHL137	25	07	3)	MCTL122	25	07	3)
GSX-R	1000	VVCY	09-	MCHL107	30	01		MCTL155	30	01	
GSX-R	1100	GV73B/C	89-92	MCHL125	35	03		MCTL104	25	03	
GSX-R	1100	GU75C	95-96	MCHL126	30	03		MCTL162	25	10	3) 6)
GSF	1200	Bandit	GV75A	96-00	MCHL110	35	03		MCTL109	35	03
GSF	1200	Bandit	VVA9	01-05	MCHL110	35	03		MCTL109	35	03
GSF	1200	Bandit	VVCB	06	MCHL110	35	03		MCTL109	35	03
GSX	1200	A3	99-00	MCHL129	35	04		---	---	---	
GSF	1250	Bandit	VVCH	07-	MCHL110	35	03		MCTL109	35	03
GSX	1250	F, FA	VVCH	10-	MCHL110	35	03		MCTL109	35	03
GSX-R	1300	Hayabusa	VVA1	99-05	MCHL131	30	03		MCTL148	30	03
GSX-R	1300	Hayabusa	VVA1	06-07	MCHL131	30	03		MCTL148	30	03
GSX-R	1300	Hayabusa	VVCK	08-	MCHL131	30	03		MCTL148	30	03
GSX	1300	BK B-King	VVCR	07-	MCHL105	30	03		MCTL112	30	03
GSX	1400	VVBN	02-06	MCHL129	35	04		---	---	---	
Triumph											
	675	Daytona	D67LC	06-	MCHL139	25	01		MCTL136	25	01
	675	Daytona, R	H67	12-	MCHL139	25	01		MCTL136	25	01
	675	Str. Triple, R	D67LD	07-12	MCHL139	25	01		MCTL136	30	01
	675	Str. Triple, R,	L67LR	13-	MCHL139	25	01		MCTL136	30	01
	675	Str. Triple, R,	L67LR	15-	MCHL139	25	01		MCTL136	30	01
	800	Tiger, XC	A08	11-	MCHL122	30	03		MCTL126	35	03
	800	Tiger, XRX, XCX	A082	15-	MCTL186	30	03		MCHL180	30	03
	885	Legend TT	T309RT	99-	MCHL120	25	03		MCTL141	30	03
	955	Speed Triple	T509	98-01	---	---	---		MCTL170	25	10 3) 6)
	955	Speed Triple i	595N	02-	---	---	---		MCTL170	30	10 3) 6)
	955	Daytona	595N	02-	---	---	---		MCTL170	40	10 3) 6)
	1050	Tiger	115NG	07-	MCHL167	25	01		MCTL171	30	01
	1050	Tiger Sport	115NG	13-	MCHL167	25	01		MCTL171	30	01
	1050	Speed Triple	515NJ	05	---	---	---		MCTL170	30	10
	1050	Speed Triple	515NJ	06-	---	---	---		MCTL170	30	10
	1050	Speed Triple	515NV	11-	---	---	---		MCTL159	25	01
	1200	Trophy SE	V13VH	13-	MCHL131	30	03		MCTL111	40	03
Yamaha											
DT	125	R	4BL	95-	---	---	---		MCTL137	25	03
DT	125	R, RH, RN	DE03	00-	---	---	---		MCTL137	25	03
DT	125	RE / X	DE06	05-	---	---	---		MCTL137	25	03
YZF	125	R	RE06	08-	---	---	---		MCTL149	30	03 7)
YZF	125	R	RE11	14-	MCHL175	25	03		MCTL185	40	03 7)10)
YZF	125	MT	RE11	14-	MCHL175	25	03		MCTL185	40	03 7)10)
FZR	600		3HE	88-93	MCHL122	30	03		---	---	---
FZR	600		3RG	88-93	MCHL122	30	03		---	---	---
FZR	600		3RH	88-93	MCHL122	30	03		---	---	---
FZR	600		4JH	94-95	MCHL140	30	03		MCTL114	40	03
FZR	600		4MH	94-95	MCHL140	30	03		MCTL114	40	03
FZS	600	Fazer	RJ02	98-03	MCHL141	35	03		MCTL111	35	03
FZ6	600	Fazer, S	RJ07	04-06	MCHL119	35	02 3)		MCTL138	35	02 3)
FZ6	600	Fazer S2	RJ14	07-	MCHL119	35	02 3)		MCTL138	35	02 3)
XJ6	600	Diversion, ABS	RJ19	09-	---	---	---		MCTL156	25	10 3) 6)
XJ6	600	Diversion, ABS	RJ22	13-	---	---	---		MCTL156	25	10 3)
YZF	600	R6	RJ03	99-02	MCHL142	25	06		---	---	---
YZF	600	R6	RJ05	03-04	MCHL152	25	06		MCTL120	30	06
YZF	600	R6	RJ09	05-06	MCHL152	25	06		MCTL120	30	06
YZF	600	R6	RJ11	06-07	MCHL143	25	03		MCTL126	30	03
YZF	600	R6	RJ15	08-	MCHL143	25	03		MCTL126	30	03
YZF	600	Thundercat	4TV	96-99	MCHL140	30	03		---	---	---
YZF	600	Thundercat	4CV	96-99	MCHL140	30	03		---	---	---
YZF	600	Thundercat	4WD	96-99	MCHL140	30	03		---	---	---
SZR	660		4SU	96-	---	---	---		MCTL108	30	03
MT-03	660		RM02	05-10	MCHL136	30	02 3)		MCTL152	25	07 3)
XT	660	X, R	DM01	04-	MCHL159	35	03		MCTL140	30	03
XT	660	Z Ténéré	DM02	08-	MCHL131	30	03		MCTL165	35	03
XT	660	Z Ténéré	DM04	12-	MCHL131	30	03		MCTL165	35	03
MT-07	700		RM04	14-	---	---	---		MCTL125	25	10
MT-07	700	Moto Cage	RM07	15-	---	---	---		MCTL125	25	10
YZF	750		4HN	93-97	MCHL123	25	03		MCTL106	30	03
YZF	750		4HR	93-97	MCHL123	25	03		MCTL106	30	03
YZF	750		4HT	93-97	MCHL123	25	03		MCTL106	30	03

							Typ				Typ	
					+ mm				- mm			
FZ8	800	Fazer	RN25	10-	MCHL149	30	01		MCTL115	25	01	
MT09	850		RN29	13-	MCHL176	25	03		MCTL178	25	03	11)
MT09	850	ABS	RN29	13-	MCHL176	25	03		MCTL178	25	03	11)
MT09	850	ABS Tracer		15-	MCHL176	25	03		MCTL178	25	03	11)
MT09	850	ABS Street Rally		14-	MCHL176	25	03		MCTL178	25	03	11)
MT09	850	ABS Sport Tracker		14-	MCHL176	25	03		MCTL178	25	03	11)
TRX	850		4UN	96-	MCHL110	30	03		---	---	---	
TDM	900		RN08	02-	---	---	---		MCTL139	35	03	
TDM	900		RN11	03-	---	---	---		MCTL139	35	03	
TDM	900		RN18	06-	---	---	---		MCTL139	35	03	
XJ	900	Diversion	4PR	95-	---	---	---		MCTL111	35	03	
XJ	900	Diversion	4KM	95-	---	---	---		MCTL111	35	03	
FZR	1000		3LE	89-95	MCHL143	45	03		---	---	---	
FZR	1000		3LF, 3GM	89-95	MCHL143	45	03		---	---	---	
FZS	1000	Fazer	RN06	01-	MCHL144	30	03		MCTL108	30	03	
FZS	1000	Fazer	RN14	04-	MCHL144	30	03		MCTL108	30	03	
FZ-1	1000	Fazer	RN16	06-	MCHL149	30	01		MCTL115	25	01	
YZF	1000	R1	RN01	98-00	MCHL146	25	06		MCTL120	30	06	
YZF	1000	R1	RN04	01	MCHL146	25	06		MCTL120	30	06	
YZF	1000	R1	RN09	02-03	MCHL152	25	06		MCTL120	30	06	
YZF	1000	R1	RN12	04-05	MCHL134	25	01		MCTL145	30	01	
YZF	1000	R1	RN12	06	MCHL134	20	01		---	---	---	
YZF	1000	R1	RN19	07-08	MCHL160	25	06		MCTL153	25	06	
YZF	1000	R1	RN22	09-	MCHL146	35	06		MCTL157	30	06	
YZF	1000	Thunderace	4VD	95-98	MCHL143	40	03		---	---	---	
YZF	1000	Thunderace	4SV, 4VF	95-98	MCHL143	40	03		---	---	---	
BT	1100	Bulldog	RP04/RP05	01-05	MCHL131	30	03		MCTL128	30	03	
XTZ	1200	Ténére, ABS	DP01	10-	---	---	---		MCTL164	35	03	
XT	1200	Z Super Tenere	DP04	14-	MCHL170	35	03		MCTL164	35	03	
XT	1200	ZE	DP04	14-	MCHL179	25	03	12)	MCTL187	25	03	
XJR	1200		4PU	94-00	MCHL145	40	05		---	---	---	
FJR	1300		RP04	01-02	MCHL143	30	03		MCTL112	30	03	
FJR	1300		RP08	03-05	MCHL143	30	03		MCTL112	30	03	
FJR	1300		RP11	03-05	MCHL143	30	03		MCTL112	30	03	
FJR	1300		RP13	06-	MCHL163	25	03		MCTL150	25	03	
FJR	1300		RP23	13-	MCHL163	25	03		MCTL150	25	03	
XJR	1300		RP02	98-01	MCHL145	40	05		---	---	---	
XJR	1300	SP	RP06	02-03	MCHL145	40	05		---	---	---	
XJR	1300	SP	RP10	04-06	MCHL145	40	05		---	---	---	
XJR	1300	SP	RP19	07-	MCHL145	40	05		---	---	---	
MT-01	1670		RP12	06-	---	---	---		MCTL151	25	10	3) 6)
MT-01	1670		RP18	07-	---	---	---		MCTL151	25	10	3) 6)

- 01) Hauptständer muss entfernt werden
- 02) der Seitenständer ist gemäß Montageanleitung um ca. 15 mm zu kürzen
- 03) Federbein muß abgepresst werden, nur bei OE Federbein montierbar
- 04) Federbein muß abgepresst werden, nur bei OE Federbein o. einstellbare Zugstufe montierbar
- 05) für Modell mit Original-Umlenkhebel mit Lochabstand größer als 100 mm
- 06) Federvorspannung anpassen
- 07) die Zahl der Sitzplätze ist auf 1 reduziert, nicht mit Sozius
- 08) Auspuffschelle und Blende bei Montage lösen
- 09) Absenkung der Telegabel möglich
- 10) Spritzschutz Hinterrad entfernen
- 11) Seitenständer um 10 mm kürzen bei abgesenkter Telegabel bei 20 mm
- 12) Hauptständer muß angepasst werden

- 01) main stand has to be removed
- 02) the side stand has to be shortened by approx. 15 mm according to mounting instructions
- 03) the strut has to be pressure tested, can be mounted only with OE strut
- 04) the strut has to be pressure tested, can be mounted only with OE strut without adjustable tension level
- 05) for model with original relay arm with hole spacing over 100 mm
- 06) adapt pre-tension of spring
- 07) The number of seats is reduced to 1, not with pillion
- 08) Release exhaust clamp and cover for installation
- 09) Lowering of front fork possible
- 10) Remove mud guard on rear wheel for fitting
- 11) Shorten side stand by 10 mm, by 20 mm with lowered front fork
- 12) Main stand has to be modified

- 01) le support principal doit être retiré.
- 02) les béquilles latérales doivent être raccourcies d'env. 15 mm conformément aux instructions de montage.
- 03) la jambe de suspension doit être démontée ; montage possible uniquement avec les jambes de suspension OE
- 04) la jambe de suspension doit être démontée ; montage possible uniquement avec les jambes de suspension OE ou les niveaux de tirage réglable.
- 05) pour les modèles avec levier de renvoi d'origine, avec écarts de plus de 100 mm entre les trous
- 06) adapter la précontrainte du ressort.
- 07) Le nombre de places assises est réduit à 1, pas de passager
- 08) Desserrer le collier d'échappement et le panneau lors du montage
- 09) Fourche télescopique abaissable
- 10) Enlever la protection anti-projections de la roue arrière
- 11) Raccourcir les béquilles de 10 mm, de 20 mm lorsque la fourche télescopique est abaissée
- 12) Le support principal doit être adapté

Typen der Höhenänderung:

- 01 Dreiecksplatten
- 02 Aufnahme für Federbeinauge
- 03 Zugstrebe
- 04 Distanzstück (Frästeil) für Stereofederbeine
- 05 Distanzstück (Frästeil) für Stereofederbeine
- 06 Zugstrebe
- 07 Aufnahme für Federbeingabel
- 08 Zugstrebe
- 09 Federbeinaufnahme BMW
- 10 Federteller

Type of height change:

- 01 Triangle plates
- 02 Seating for strut eye
- 03 Tie rod
- 04 Spacer (milled part) for stereo shocks
- 05 Spacer (milled part) for stereo shocks
- 06 Tie rod
- 07 Seating for strut fork
- 08 Tie rod
- 09 Strut seating BMW
- 10 Spring plate

Types de modifications de hauteur:

- 01 Plaques triangulaires
- 02 Logement pour oeil de jambe de suspension
- 03 Tirant
- 04 Pièce d'écartement (pièce fraisée) pour jambes de suspension doubles
- 05 Pièce d'écartement (pièce fraisée) pour jambes de suspension doubles
- 06 Tirant
- 07 Logement pour la fourche de la jambe de suspension
- 08 Tirant
- 09 Logement pour jambe de suspension BMW
- 10 Coupelle de ressort



KENNZEICHENHALTER

SUPPORT POUR PLAQUE

REGISTRATION PLATE HOLDERS

KENNZEICHENHALTER *SUPPORT POUR PLAQUE* REGISTRATION PLATE HOLDERS



Formschöner, leichter Kennzeichenhalter

- » sehr edel aus Aluminium, schwarz beschichtet
- » inkl. aller Montageteile, einfach an den Originalpunkten zu montieren
- » alle Nummernschildhalter werden, wenn nicht anders angegeben, ohne Beleuchtungselemente geliefert
- » wo nötig, die Kennzeichenleuchte MSH 900 + MSH 902 auswählen (siehe Seite 5.60)
- » bei den meisten Modellen können die Original-Blinker nicht verwendet werden

Attractively formed, lightweight registration plate holder

- » high quality aluminium, with black coating
- » includes all components, easy to mount at the original points
- » unless otherwise indicated, all registration plate holders will be supplied without lighting elements
- » where necessary, select the registration plate bulb MSH 900 + MSH 902 (see page 5.60)
- » for most models, the original indicators cannot be used

Support pour plaque élégant et léger

- » support pour plaque d'immatriculation en aluminium, avec revêtement noir
- » toutes les pièces de montage sont incluses pour un montage plus simple aux points d'origines
- » sauf mention contraire, tous les supports pour plaque d'immatriculation sont fournis sans éclairage
- » en cas de besoin, choisir les feux d'éclairage MSH 900 + MSH 902 (cf. page 5.60)
- » l'éclairage d'origine de la plaque d'immatriculation et le clignotant d'origine ne peuvent pas être utilisés sur la plupart des modèles

EINBAUBEISPIELE EXEMPLES D'INSTALLATION INSTALLATION EXEMPLES



Beispielbild Kennzeichenhalter mit LED-Leuchte integriert:

- » Rücklicht
- » Bremslicht
- » Schildbeleuchtung

Sample image for registration plate holder with integrated LEDs:

- » Tail light
- » Brake light
- » Plate light

Exemple Support pour plaque d'immatriculation avec éclairages LED intégrés :

- » Feu arrière
- » Feu de stop
- » Éclairage de plaque



Bestell-Nr.
Order no.
N° comm.
MSH400

Universalhalter zum Selbsteinpassen
Universal holder, can be adjusted to fit all makes
Support universel qui s'ajuste aux besoins individuels



Bestell-Nr.
Order no.
N° comm.
MSH401

Vario-Universalhalter, verstellbar
Variable universal holder, adjustable
Support universel variable, réglable



Schraubenset 15-tlg mit M5-Gewinde, zur Montage des Nummernschildes
15 part M5 screw set, for correct mounting of the registration plate
Set de 15 vis avec filetages M5, pour un montage professionnel de la plaque d'immatriculation

Bestell-Nr.
Order no.
N° comm.
MSH901



Bestell-Nr.
Order no.
N° comm.
MSH900

Nummernschild - beleuchtung
registration plate lighting
Eclairage pour plaque d'immatriculation



Bestell-Nr.
Order no.
N° comm.
MSH902







Nummernschild - beleuchtung LED, gefrästes Alugehäuse
LED registration plate lighting, milled aluminum frame
Eclairage LED pour plaque d'immatriculation avec boîtier en aluminium fraisé



Bestell-Nr.
Order no.
N° comm.
MSH903

Universal-Beleuchtung, zur Montage an der Heckunterverkleidung.
Universal light, for mounting on the lower side of rear fairing.
Éclairage universel, pour montage sous la coque arrière.

						MSH900	MSH902		
BMW									
S	1000	RR		09-	MSH 130	Original			
S	1000	R		14-	MSH 130	Original			
Ducati									
	848	Streetfighter		11-	MSH 120	---			5) - MSH903
	1098	Streetfighter		09-	MSH 120	---			5) - MSH903
Honda									
CBR	600	F	PC41	11-	MSH 106	Original			3)
CB	600	Hornet	PC41	11-	MSH 106	Original			3)
CBR	600	RR	PC37	03-04	MSH 100	MSH 900	MSH 902		
CBR	600	RR	PC37	05-06	MSH 103	MSH 900	MSH 902		

						 MSH900	 MSH902	
NC	700	S	RC61	12-	MSH 110	inkl. LED Leuchte		1), 2)
NC	700	X	RC63	12-	MSH 110	inkl. LED Leuchte		1), 2)
CBR	954	RR	SC50	02-03	MSH 101	Original		
CBR	1000	RR	SC57	04-07	MSH 102	MSH 900	MSH 902	4)
CBR	1000	RR	SC59	08-09	MSH 105	Original		3)
CB	1000	R	SC60	08-	MSH 106	Original		3)
Kawasaki								
ER-6	650	N	ER650A	06-08	MSH 203	MSH 900	MSH 902	
ER-6	650	F	EX650A	06-08	MSH 203	MSH 900	MSH 902	
ER-6	650	F	EX650C	09-11	MSH 208	MSH 900	MSH 902	
ER-6	650	F	EX650E	12-	MSH 210	---		2), 5) - MSH903
ZX-6R	600	RR Ninja	ZX600K	03-	MSH 200	MSH 900	MSH 902	
ZX-6R	636	Ninja	ZX600B	03-04	MSH 200	MSH 900	MSH 902	
ZX-6R	636	Ninja	ZX600C	05-06	MSH 202	MSH 900	MSH 902	
ZX-6R	600	Ninja	ZX600P	07-08	MSH 205	inkl. LED Leuchte		1)
ZX-6R	600	Ninja	ZX600R	09-12	MSH 207	Original		
ZX-6R	636	Ninja	ZX636F	13-	MSH 207	Original		
Z	750		ZR750J	04-06	MSH 200	MSH 900	MSH 902	
Z	750		ZR750L	07-10	MSH 206	MSH 900	MSH 902	
Z	750	R	ZR750N	11-12	MSH 206	MSH 900	MSH 902	
Z	800	R	ZR800A	13-	MSH 211	---		2), 5) - MSH903
Z	1000		ZRT00A	03-06	MSH 200	MSH 900	MSH 902	
Z	1000		ZRT00B	07-09	MSH 206	MSH 900	MSH 902	
Z	1000		ZRT00C, D	10-13	MSH 209	MSH 900	MSH 902	
Z	1000			14-	MSH 213	---	---	2), 5) - MSH903
Z	1000	SX	ZXT00G	11-13	MSH 209	MSH 900	MSH 902	
Z	1000	SX	ZXT00G	14-	MSH 214	---	---	2), 5) - MSH903
ZX-10R	1000	Ninja	ZXT00C	04-05	MSH 201	MSH 900	MSH 902	
ZX-10R	1000	Ninja	ZXT00D	06-07	MSH 204	MSH 900	MSH 902	
ZX-10R	1000	Ninja	ZXT00E	08-10	MSH 207	Original		
ZX-10R	1000	Ninja	ZXT00F	11-	MSH 212	MSH 900	MSH 902	
Suzuki								
GSXR	600		WVB2	04-05	MSH 302	MSH 900	MSH 902	
GSXR	600		WCE	06-07	MSH 305	MSH 900	MSH 902	
GSXR	600		WVCV	08-10	MSH 307	MSH 900	MSH 902	
GSXR	600		WVC3	11-	MSH 310	MSH 900	MSH 902	
SV	650		WVBY	03-	MSH 300	Original		
GSR	750		C5	11-	MSH 311	MSH 900	MSH 902	
GSXR	750		WVB3	04-05	MSH 302	MSH 900	MSH 902	
GSXR	750		CF	06-07	MSH 305	MSH 900	MSH 902	
GSXR	750		WVCW	08-10	MSH 307	MSH 900	MSH 902	
GSXR	750		WVC4	11-	MSH 310	MSH 900	MSH 902	
GSXR	1000		WVBZ	03-04	MSH 301	Original		
GSXR	1000		WVB6	05-06	MSH 303	MSH 900	MSH 902	
GSXR	1000		WVCL	07-08	MSH 303	MSH 900	MSH 902	
GSXR	1000		WVCY	09-	MSH 309	MSH 900	MSH 902	
SV	1000		WVBX	03-	MSH 300	Original		
GSX	1300	B-King	WVCR	07-	MSH 308	inkl. LED Leuchte		1)
Triumph								
	1050	Speed Triple	515NJ	05-07	MSH 600	Original		
Yamaha								
FZ6	600	N	RJ07	04-	MSH 503	MSH 900	MSH 902	
XJ6	600	F Diversion	RJ19	09-	MSH 508	MSH 900	MSH 902	
YZF	600	R6	RJ03	01-02	MSH 501	MSH 900	MSH 902	
YZF	600	R6	RJ05, RJ09	03-05	MSH 500	MSH 900	MSH 902	
YZF	600	R6	RJ11	06-11	MSH 504	MSH 900	MSH 902	
MT-07	700	RM04	RM04	14-	MSH 509	---	---	2), 5) - MSH903
FZ8	800	, Fazer	RN25	10-	MSH 505	MSH 900	MSH 902	
MT-09	850		RN29	13-	MSH 510	---	---	2), 5) - MSH903
FZ1	1000	N	RN16	06-	MSH 505	MSH 900	MSH 902	
YZF	1000	R1	RN09	02-03	MSH 500	MSH 900	MSH 902	
YZF	1000	R1	RN12	04-06	MSH 502	MSH 900	MSH 902	
YZF	1000	R1	RN19	07-08	MSH 506	MSH 900	MSH 902	
YZF	1000	R1	RN22	09-	MSH 507	MSH 900	MSH 902	

- 1) inkl. LED - Rücklicht und LED - Kennzeichenbeleuchtung
2) Neigung verstellbar
3) inkl. Seitenverstrebung
4) Seitenverkleidung v. Auspuff muss entfernt werden
5) Original Kennzeichenleuchte durch eine Variante zur Montage unter Heckverkleidungen ersetzen

- 1) incl. LED rear light and LED registration plate lighting
2) Inclination adjustable
3) incl. side braces
4) exhaust side cover must be removed
5) replace original number plate light with a version for mounting on the lower side of rear fairings

- 1) avec feu arrière LED et éclairage LED de la plaque d'immatriculation
2) Inclinaison réglable
3) avec renfort latéral
4) le revêtement latéral devant l'échappement doit être retiré.
5) remplacer l'éclairage de plaque d'immatriculation d'origine par un modèle à monter sous la coque arrière.

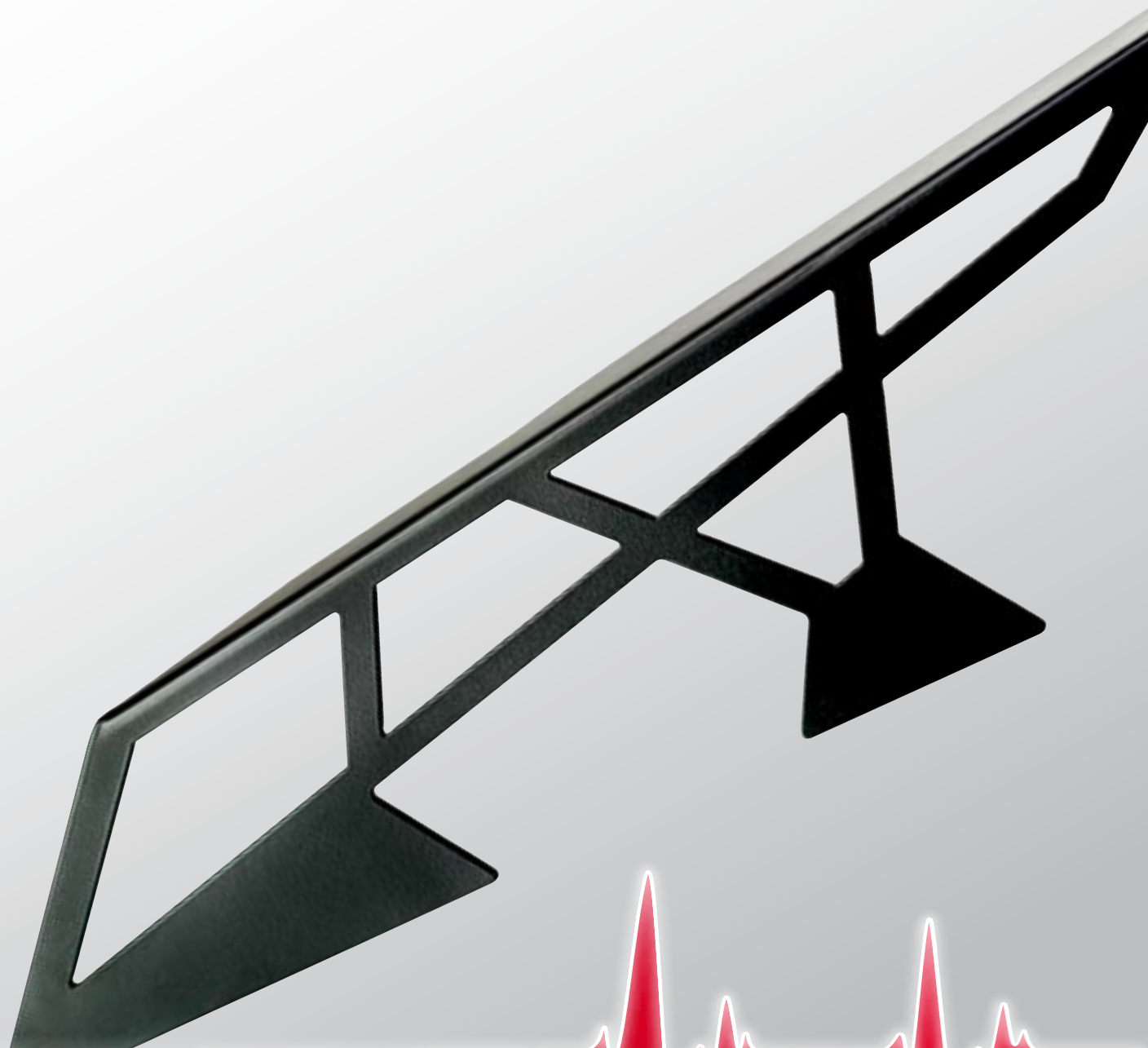

KETTENSCHÜTZER

PROTECTION DE CHAÎNE

CHAIN GUARDS

KETTENSCHÜTZER

PROTECTION DE CHAÎNE CHAIN GUARDS

Kettenschützer aus Aluminium

- » formschönes, attraktives Design
- » hochwertige Ausführung
- » metallische Pulverbeschichtung
- » korrosionsgeschützte Oberfläche
- » leicht zu reinigen und zu pflegen
- » stabile, passgenaue Konstruktion

Aluminium chain guard

- » attractive design with beautiful lines
- » high-quality product
- » metallic powder coating
- » corrosion-resistant surface
- » easy to clean and maintain
- » robust, accurately-fitting design

Protection de chaîne en aluminium

- » design attractif et ergonomique
- » Modèle de grande qualité
- » revêtement par poudre, métallique
- » surface protégée contre la corrosion
- » facile à nettoyer et à entretenir
- » construction stable et ajustée



Passend für fast alle Modelle ohne Schwingenoberzug!

Fits most models without top-mounted stabiliser on swingarm!

Convient pour presque tous les modèles, sans revêtement sur la bielle oscillante!

Silber
silver
argent

Schwarz
black
noir

MCK2222

MCK2222-S

Universal-Kettenschutz mit maximalem Befestigungsbereich von 377 mm.

Universal chainguard with maximum fitting range of 377 mm.

Protection de chaîne universelle avec distance maximale entre les 2 points de fixation de 377 mm.

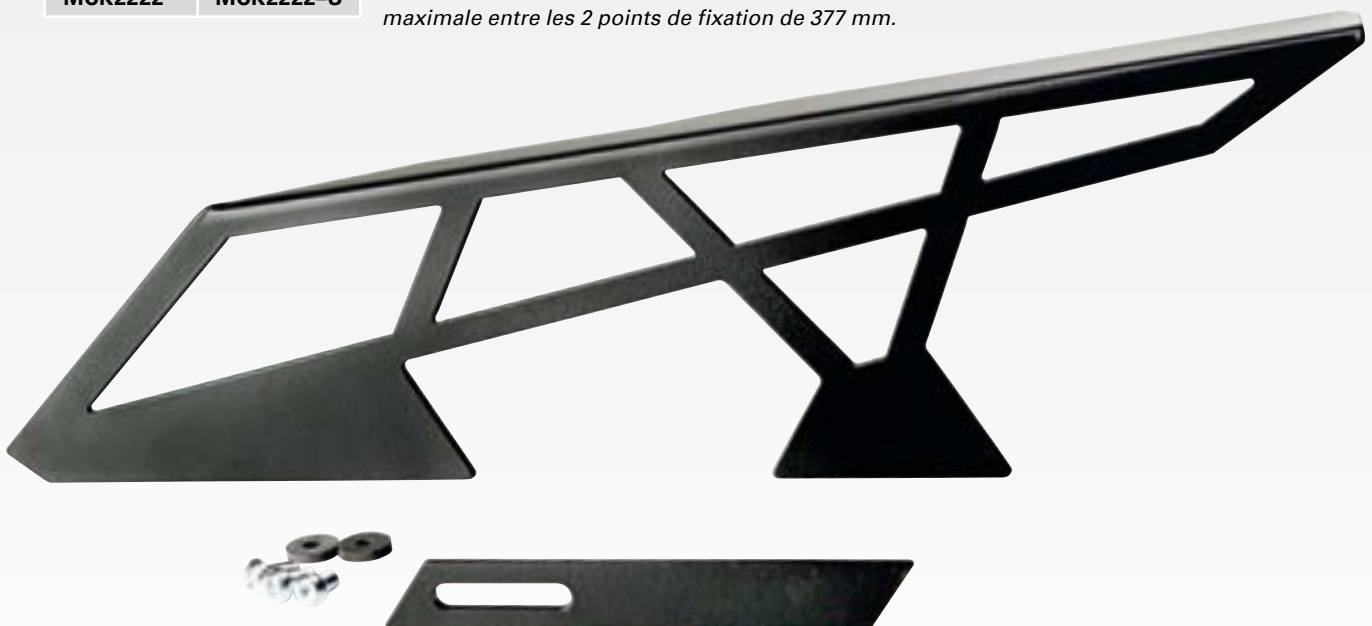



CZ Vzhledem k intenzívnímu konstrukčnímu a vývojovému programu TRW Automotive, si výrobce vyhrazuje právo změnit specifikaci bez předchozího upozornění. Proto TRW Automotive nemůže převzít odpovědnost za případné nepřesnosti.

Všechna práva vyhrazena.

Žádná část této publikace nesmí být jakýmkoliv způsobem reprodukována ani kopírována bez předchozího souhlasu TRW Automotive. Platí Všeobecné obchodní podmínky TRW Automotive.

FI Vaikka tämän julkaisun tiedot on koottu mahdollisimman huolellisesti, TRW Automotive ei voi ottaa laillista vastuuta mahdollisista virheellisyyksistä. TRW Automotive: llä on tehokas suunnittelu- ja kehitysohjelma, jonka seurauksena tuotetietojen muutokset saattavat tulla tarpeellisiksi. TRW Automotive pidättää oikeuden tuotetietojen muutoksiin milloin tahansa ilman ennakoitua varmistusta varmistaakseen tuotelinjan parhaan mahdollisen tehokkuuden.

Kaikki oikeudet pidätetään.

Mitään tämän julkaisun osaa ei saa kopioida, tallentaa tietokonejärjestelmään tai toimittaa edelleen missään muodossa tai millään tavalla, elektronisesti, mekaanisesti, valokopioina, tallentamalla tai muutoin, ilman TRW Automotive: n lupaa. TRW Automotive. -yhtiön „Yleiset sopimusehdot“ pätevät.

DE Bei Zusammenstellung der in dieser Veröffentlichung enthaltenen Informationen wurde mit größter Sorgfalt vorgegangen. TRW Automotive kann jedoch rechtlich nicht für etwaige Ungenauigkeiten zur Verantwortung gezogen werden. Ein kontinuierliches Design- und Entwicklungsprogramm wird von TRW Automotive betrieben, wodurch es durchaus möglich ist, dass sich Produktdaten ändern. TRW Automotive behält sich das Recht vor, Spezifikationen ohne Notiz jederzeit zu ändern, um eine optimale Leistung der Produkte zu garantieren.

Alle Rechte vorbehalten.

Kein Teil dieser Veröffentlichung darf ohne vorherige Genehmigung von TRW Automotive abgedruckt, in einem Datenverarbeitungssystem gespeichert oder auf irgendeine Art und Weise, sei es elektronisch, mechanisch, durch Foto kopien, Aufnahme oder auf andere Art übertragen werden. Es gelten die „Allgemeinen Geschäftsbedingungen“ von TRW Automotive.

FR Il a été apporté une attention particulière pour garantir l'exactitude des renseignements contenus dans cette publication par TRW Automotive, mais la société décline toute responsabilité légale à cet égard. TRW Automotive poursuit un programme intensif de conception et de développement qui peut entraîner la modification des spécifications des produits. TRW Automotive se réserve le droit de modifier les spécifications, sans préavis et si cela est nécessaire, pour assurer les performances optimales de sa gamme de produits.

Tous droits réservés.

Toute reproduction, mémorisation dans un système informatique ou transmission sous quelle que forme que ce soit, ou par tout moyen électronique, mécanique, par photocopie, enregistrement ou autre de cette publication est interdit sans l'autorisation préalable de TRW Automotive. Les «conditions générales du contrat» de TRW Automotive seront appliquées.

DK TRW Automotive har ved udarbejdelse af informationerne i denne publikation gjort alt for at undgå fejl, og kan ikke påtage sig juridisk ansvar for evt. fejl. TRW Automotive har et intensivt program med konstruktion og udvikling, som godt kan ændre produktspecifikationen. TRW Automotive forbeholder sig ret til at ændre specifikationer uden varsel og når det er nødvendigt for at sikre produktudvalgets optimale ydelse.

Alle rettigheder forbeholdes.

Ingen del af denne publikation må gengives, opbevares i edb-anlæg eller overføres i nogen form eller på nogen måde, hveken elektronisk, mekanisk, ved fotokopiering, optagelse eller på anden måde, uden forudindhentet tilladelse fra TRW Automotive. TRW Automotive's generelle forretningsbetingelser er gældende.

GB Whilst every care has been taken in compiling the information in this publication, TRW Automotive cannot accept legal liability for any inaccuracies. TRW Automotive has an intensive programme of design and development which may well alter product specification. TRW Automotive reserve the right to alter specifications without notice and whenever necessary to ensure optimum performance from its product range.

All Rights Reserved.

No part of this publication may be reproduced, stored in a retrieval system, or transmitted in any form, or by any means, electronic, mechanical, photocopying, recording or otherwise, without the prior permission of TRW Automotive. TRW Automotive's "General Terms and Conditions of Business" apply.

ES Aunque hemos tomado todas las precauciones necesarias al elaborar esta publicación, TRW Automotive no se responsabiliza de las inexactitudes que puedan aparecer en la misma. TRW Automotive sigue un programa intensivo de diseño e investigación que podría en cualquier momento alterar la especificación de los productos. Para garantizar el mejor funcionamiento posible de sus productos, TRW Automotive se reserva el derecho de realizar cambios en las especificaciones sin previo aviso.

Todos los derechos reservados.

No se permite copiar y almacenar el contenido de esta publicación en soportes electrónicos, ni su transmisión por ningún medio electrónico o mecánico, ya sea por fotocopias, grabaciones o por cualquier otro medio, sin la autorización expresa por parte de TRW Automotive. Serán aplicables las condiciones generales de contrato de TRW Automotive.

GR Η συλλογή των πληροφοριών που περιέχονται στην έκδοση αυτή έγινε με τη μεγαλύτερη δυνατή επιμέλεια. Ωστόσο, η TRW Automotive δεν μπορεί να θεωρηθεί νομικά υπεύθυνη για ενδεχόμενες ανακρίβειες. Λόγω του προγράμματος σχεδιασμού και ανάπτυξης, το οποίο η TRW Automotive εφαρμόζει διαρκώς, υπάρχει η πιθανότητα αλλαγών στα δεδομένα των προϊόντων. Η TRW Automotive διατηρεί το δικαίωμα αλλαγής των τεχνικών χαρακτηριστικών οποιαδήποτε στιγμή και χωρίς προειδοποίηση, έτσι ώστε να μπορεί να διασφαλίσει τη βέλτιστη απόδοση των προϊόντων.

Με επιφύλαξη κάθε δικαιώματος.

Κανένα μέρος αυτής της έκδοσης δεν μπορεί να αναπαραχθεί, αποθηκευτεί ή μεταδοθεί με οποιαδήποτε μορφή ή οποιοδήποτε μέσο, ηλεκτρονικό, μηχανικό, φωτοτυπικό, εγγραφής ή άλλο, χωρίς την προηγούμενη συγκατάθεση της TRW Automotive. Ισχύουν οι „Γενικοί όροι και προϋποθέσεις“ της TRW Automotive.



(HU) A jelen nyomtatványban feltüntetett információk összeállításakor a legnagyobb gondossággal jártunk el. A TRW Automotive azonban nem vonható felelősségre az esetleges pontatlanságok miatt. A TRW Automotive folyamatos dizájn- és fejlesztőprogramot üzemeltet, amely miatt előfordulhat, hogy módosulnak a termékadatok. A TRW Automotive fenntartja a jogot, hogy a specifikációkat értesítés nélkül módosítsa a termékek optimális teljesítménye érdekében.

Valamennyi jog fenntartva.

A jelen kiadvány részei a TRW Automotive előzetes engedélye nélkül nem tehetők közzé, nem tárolhatók adatfeldolgozó rendszerben, és nem továbbíthatók más, elektronikai, mechanikai úton, fénymásolatban, felvételben vagy egyéb formában. Ide vonatkozóan a TRW Automotive „Általános szerződési feltételei” vannak érvényben.

(IT) Nonostante le informazioni contenute in questa pubblicazione siano state compilate con la massima accuratezza possibile, TRW Automotive non accetta alcuna responsabilità legale in caso di imprecisioni. TRW Automotive ha un programma intensivo di progettazione e sviluppo che può comportare la modifica delle specifiche del e sviluppo che può comportare la modifica delle specifiche del prodotto. TRW Automotive si riserva il diritto di modificare le specifiche senza preavviso e quando necessario per assicurare prestazioni ottimali della sua linea di prodotti.

Tutti i diritti riservati.

Nessuna parte di questa pubblicazione può essere prodotta, memorizzata in un sistema a ritrovamento, oppure trasmessa in qualsiasi forma, o con qualsiasi mezzo, elettronico, meccanico, di fotocopiatura, registrazione o altro, senza previa autorizzazione della TRW Automotive. Vigono i „termini e le condizioni generali” di TRW Automotive.

(NL) Hoewel alle mogelijke zorg werd besteed bij het samenstellen van de informatie in deze publicatie, kan TRW Automotive geen enkele wettelijke aansprakelijkheid accepteren voor eventuele onnauwkeurigheden. TRW Automotive voert een intensief ontwerp- en ontwikkelingsprogramma waardoor het zeer goed mogelijk is dat specificaties van producten dienen te worden gewijzigd. TRW Automotive behoudt zich als onderneming en rechtspersoon het recht voor om specificaties zonder voorafgaande kennisgeving en wanneer dat noodzakelijk wordt geacht te wijzigen teneinde optimale prestatie-karakteristieken van alle producten te kunnen garanderen.

Alle rechten voorbehouden.

Niets uit deze publicatie mag worden gereproduceerd, opgeslagen in een zogenaamd retrieval-systeem of overgebracht op welke wijze dan ook, zij het elektronisch, mechanisch, door middel van fotokopieën, opnamen of op welke andere wijze dan ook, zonder voorafgaande schriftelijke toestemming van TRW Automotive. De algemene voorwaarden van TRW Automotive zijn van toepassing.

(PL) Przy opracowywaniu niniejszej publikacji dołożono wszelkich starań w celu zapewnienia prawidłowości informacji w niej zawartych, ale TRW Automotive nie może być pociągnięty do odpowiedzialności prawnej za ewentualne niedokładności. Realizowany przez TRW Automotive program ciągłego rozwoju może spowodować zmianę parametrów produktu. W celu zapewnienia optymalności swojej rodziny produktów, TRW Automotive zastrzeże za siebie prawo do wprowadzania zmian do specyfikacji, w tym bez zapowiedzi jeśli to konieczne.

Wszelkie prawa zastrzeżone.

Wszelkie powielanie, zapisywanie w systemie komputerowym lub przekazywanie w jakiegokolwiek formie, lub przez jakiegokolwiek nośnik elektroniczny, mechaniczny, przez kopiowanie, rejestrowanie lub w inny sposób, są zabronione bez uprzedniego zezwolenia TRW Automotive. Obowiązują „Ogólne Warunki Handlowe” firmy TRW Automotive.

(PT) O resumo das informações contidas nesta publicação foi efectuado com grande cuidado. No entanto, a TRW Automotive não pode ser legalmente responsabilizada por possíveis imprecisões. A TRW Automotive está a levar a cabo um programa de design e de desenvolvimento contínuo, pelo que é possível existirem alterações aos dados do produto. A TRW Automotive reserva-se o direito de alterar em qualquer momento as especificações sem notificação prévia, de forma a garantir um desempenho ideal do produto.

Todos os direitos reservados.

Nenhuma parte desta publicação pode ser impressa, armazenada num sistema de tratamento de dados ou difundida de qualquer modo, seja electrónico, mecânico, por fotocópia, fotografia ou de outra forma. São válidos os „Termos e Condições Gerais” da TRW Automotive.

(RO) TRW Automotive a acordat o deosebită atenție garanțiilor exactității informațiilor cuprinse în acest document, însă își declină orice responsabilitate legală în această privință. TRW Automotive urmărește un program intensiv de concepție și dezvoltare care poate antrena modificarea datelor tehnice ale produselor. TRW Automotive își rezervă dreptul de a modifica aceste date tehnice fără preaviz, dacă va fi necesar, pentru a asigura performanțe optime gamei sale de produse.

Toate drepturile sunt rezervate.

Orice reproducere, memorizare sau stocare într-un sistem de prelucrare a datelor sau transmiterea sub orice formă, prin mijloace electronice, mecanice, fotocopiare, înregistrare sau alte procedee, sunt interzise în lipsa autorizației prealabile a TRW Automotive. Sunt aplicabile „Condițiile contractuale generale” ale firmei TRW Automotive.

(RU) Несмотря на то, что для проверки информации, содержащейся в данной публикации, были предприняты все меры, компания TRW Automotive не несет юридической ответственности за какие-либо неточности. Компания TRW Automotive реализует интенсивную программу проектирования и разработки, которая может привести к изменению технических характеристик изделия. TRW Automotive оставляет за собой право изменять технические характеристики без предварительного уведомления, и там, где это необходимо, для обеспечения оптимальных эксплуатационных характеристик своих изделий.

Все права защищены.

Никакая часть данной публикации не может быть воспроизведена, занесена в поисковую систему или передана в какой-либо форме или какими-либо способами – электронными, механическими, фото - копированием, записью или другими, без предварительного разрешения компании TRW Automotive. Действуют „Общие коммерческие условия” компании TRW Automotive.

(TR) Yayınlama ve bilgi toplama aşamasında her türlü özen gösterilmiş oldugundan TRW Automotive, herhangi bir kusurlu maldaki yasaltaah-hütleri kabul edemez. TRW Automotive dizayn ve geliştirmede ürün spesifikasyonlarını değiştirebilecek yoğun bir programa sahiptir. TRW Automotive ürün grubunun performansını arttırmak amacı ile herhangi bir uyarıda bulunmadan ürün spesifikasyonlarını değiştirme ve gerekli görüldüğü takdirde her ne zaman olursa olsun ürününü düzeltme hakkını saklı tutar.

Tüm Hakları Saklıdır.

Bu yayının hiçbir bölümü öncelikle TRW Automotive'den izin alınmaksızın düzeltilerek saklanamaz veya herhangi bir biçimde nakledilemez; başka bir suretle elektronik ve mekanik olarak kopyalanamaz veya kaydedilemez. TRW Automotive'nin „Genel İş Şartları” geçerli olmaktadır.

**CZ****DŮLEŽITÉ:**

Berte následující v úvahu: v katalogu udané roky modelů odpovídají skutečným dobám produkce jmenovaných modelů motorových vozidel. Proto může v jednotlivých případech v papírech vozidla uvedený datum prvního přihlášení vozidla ležet mimo udané doby.

GR**ΣΗΜΑΝΤΙΚΟ:**

Προσοχή: Τα έτη κατασκευής που αναφέρονται στον κατάλογο αντιστοιχούν στα πραγματικά χρονικά διαστήματα παραγωγής των εκάστοτε μοντέλων. Για το λόγο αυτό δεν αποκλείεται να ναγράφεται στα χαρτιά του αυτοκινήτου ως ημερομηνία πρώτης κυκλοφορίας, μία ημερομηνία εκτός των ως άνω χρονικών διαστημάτων.

DE**WICHTIG:**

Bitte beachten: Die im Katalog angegebenen Modellbaujahre entsprechen den Produktionszeiträumen der jeweiligen Fahrzeugmodelle in den Regionen. Fallweise kann das in den Fahrzeugpapieren genannte Erstzulassungsdatum davon abweichen.

PL**WAŻNE:**

Proszę pamiętać: podane w katalogu lata modelowe odpowiadają rzeczywistym okresom produkcji poszczególnych modeli pojazdów. Dlatego w niektórych przypadkach data pierwszej rejestracji, podana w dokumentach samochodu, może wykraczać poza podany okres.

ES**IMPORTANTE:**

Rogamos tener en cuenta: Los años de construcción de los modelos indicados en el catálogo corresponden a los periodos de producción reales del respectivo modelo de vehículo. Por esta razón, en casos aislados, la fecha de la primera matriculación mencionada en la documentación del vehículo puede hallarse fuera de estos periodos mencionados.

PT**IMPORTANTE:**

Observe, sff.: Os anos de construção fornecidos no catálogo correspondem realmente aos períodos de produção dos respectivos modelos de veículos. Entretanto, em casos isolados, a data da primeira matrícula citada na documentação do veículo pode encontrar-se fora dos períodos citados.

FR**IMPORTANT:**

Veuillez tenir compte que les années des modèles indiquées dans le catalogue correspondent aux périodes de production réelles des modèles de véhicules respectifs. C'est pourquoi la date du premier enregistrement indiquée dans les papiers des véhicules est différente de ces périodes dans certains cas.

RU**ВАЖНАЯ ИНФОРМАЦИЯ:**

Пожалуйста, обратите Ваше внимание: годы выпуска моделей, указанные в каталоге, соответствуют действительному времени изготовления данных моделей автомобилей. По этой причине в отдельных случаях дата первого допуска, приведенная в документах автомобиля, может находиться за пределами этого времени.

GB**IMPORTANT:**

Please note: The model year information inside the catalogue corresponds to the production year of the relevant models. Therefore, in some cases it is possible that the vehicle registration date in the car documents is different to the model year information..

TR**ÖNEMLİ:**

Lütfen dikkat ediniz: Katalogda gösterilen model yılı aracın imâl edildiği yılı göstermektedir. Bundan dolayı bazan aracın ilk ruhsatlandırıldığı tarihin model yılından farklı olması mümkündür.

D**GB****FR****CZ****ES****GR****PL****RU****TR****i**

Fußrasten-anlagen	Rearset	Kits de commandes reculées	Stupačky	Instalaciones reposapiés	Εξοπλισμός υποστηρίγματος ποδιών	Podnóżki	Подножки	Ayak mesnet donanımları
Fußrasten-Adapterplatten	Footrest adjuster plate	Platines de réglage pour commandes reculées	Adaptérové desky stupaček	Placa adaptadora de reposapiés	Υποστηρίγματα ποδιών-Πλάκες προσαρμογέα	Płyty adapterów podnóżka	Адаптеры для подножек	Ayak mesnedi adaptör plakaları
Austausch-Fußrastengelenk	Footrest pivots	Supports de repose-pieds	Výměna – kloub stupačky	Sustitución articulación reposapiés	Αντικατάσταση-Αρθρωση υποστηρίγματος ποδιού	Wymienny przegub podnóżka	Шарниры подножек для замены	Ayak mesnet mafsalı deđiştirme
Lenker-Modell	Handlebar model	Types de guidons	Model řídítek	Modelo manillar	Μοντέλο τιμονιού	Model kierownicy	Тип руля	Kol Modeli
Lenkerenden Standard	Bar Ends Standard	Embouts pour guidons standard	Koncovky řídítek Standard	Extremos manillar estándares	Άκρες τιμονιού Standard	Końcówki kierownicy standard	Наконечники руля „стандарт“	Kol uçları Standart
Classic	Classic	classiques	Classic	clásicos	Classic	Classic	„классик“	Klasik
Durchmesser	Diameter	Diamètre	Průměr	Diámetro	Διάμετρος	Średnica	Диаметр	Çapı
Basis-Set	The basic set	Le kit de base	Základní sada	Set básico	Βασικό σετ	Zestaw podstawowy	Базовый комплект	Temel Set
Distanzhülsen	Spacer sleeves	Les entretoises	Distanční objímky	Casquillos distanciadores	Χιτώνια απόστασης	Tulejki dystansowe	Распорные гильзы	Mesafe kovanları
Bremshebel	Brakelever	Levier des frein	Brzdová páka	Maneta de freno	Μανετα φρενου	Dźwignia hamulca	Тормозной рычаг	Fren kolu
Kupplungshebel	Clutchlever	Levier des embrayage	Páka spojky	Maneta de embrague	Μανετα αμπραγιαζ	Dźwignia sprzęgła	Рычаг сцепления	Debriyaj kolu
Tieferlegung	Suspension Lowering Kit	Biellette de suspension	Snížení	Descenso parte trasera	Χαμηλή ρύθμιση ανάρτησης	Obniżenie zawieszenia	Уменьшение высоты	Alt kalıp
Heckhöherlegung	Suspension Jack Up Kit	Correcteur de hauteur de selle	Zvýšení zádě	Elevación parte trasera	Υψηλή ρύθμιση πίσω ανάρτησης	Podwyższenie tyłu	Увеличение высоты задка	Arka üst kalıp
Veränderung nach unten	Downward adjustment	Changement vers le bas	Změna dolů	Modificación hacia abajo	Αλλαγή προς τα κάτω	Zmiana w dół	Изменение вниз	Deđişim aşığıya
Veränderung nach oben	Upward adjustment	Changement vers le haut	Změna nahoru	Modificación hacia arriba	Αλλαγή προς τα επάνω	Zmiana do góry	Изменение вверх	Deđişim yukarıya
Kennzeichenhalter	Registration plate holder	Support de plaque	Držák označení	Soporte matrícula	Στήριγμα πινακίδας	Wspornik tablicy rejestracyjnej	Держатель номерного знака	Plaka tutucusu
Kettenschützer	Chain guards	Protection de chaîne	Chráníč řetězu	Protector de la cadena	Προστατευτικά αλυσίδας	Ostona łańcucha	Кожух цепи	Zincir koruyucu



